

PART NO. ENMABK-EN1-2

**HITACHI**

Reliable solutions

# Operator's Manual

# ZAXIS

## 17U-6

## 19U-6

## 26U-6

## Hydraulic Excavator

Serial No.  
ZX17U-6 030001 and up  
ZX19U-6 030001 and up  
ZX26U-6 050001 and up

ZX17U-6 • 19U-6 • 26U-6 HYDRAULIC EXCAVATOR OPERATOR'S MANUAL

ENMABK-EN1-2

 Hitachi Construction Machinery Co., Ltd.

URL:<http://www.hitachi-c-m.com>

PRINTED IN THE NETHERLANDS 2021, 04

**CALIFORNIA**

**Proposition 65 Warning**

**Diesel engine exhaust and some of its constituents are known to the State of California to cause cancer, birth defects, and other reproductive harm.**

## INTRODUCTION

---

**Read this manual** carefully to learn how to operate and service your machine correctly. Failure to do so could result in personal injury or machine damage.

**This standard specification machine** can be operated under the following conditions without being modified.  
Atmospheric Temperature: -20 °C to 40 °C (-4 °F to 104 °F) Altitude: 0 m to 1500 m (0 ft to 4900 ft)

In case the machine is used under conditions other than described above, consult your authorized dealer.

**This manual should be considered** a permanent part of your machine and should remain with the machine when you sell it.

**This machine is of metric** design. Measurements in this manual are metric. Use only metric hardware and tools as specified.

**Right-hand and left-hand** sides are determined by facing in the direction of forward travel.

**Write product identification numbers** in the Machine Numbers section. Accurately record all the numbers to help in tracing the machine should it be stolen. Your dealer also needs these numbers when you order parts. If this manual is kept on the machine, also file the identification numbers in a secure place off the machine.

Be sure to use fuel that complies with JIS K-2204, EN-590 or ASTM D-975 which contains 15 ppm or lower sulfur. Also use fuel that complies with solid contamination level of class 18/16/13 of ISO4406-1999 (solid contamination includes dust). If the fuel specified above is not used, exhaust gas that exceeds the regulation values may be discharged, causing serious problem on the engine. Consult your authorized dealer.

**Warranty** is provided as a part of Hitachi's support program for customers who operate and maintain their equipment as described in this manual. The warranty is explained on the warranty certificate which you should have received from your dealer.

This warranty provides you the assurance that Hitachi will back its products where defects appear within the warranty period. In some circumstances, Hitachi also provides field improvements, often without charge to the customer, even if the product is out of warranty. **Should the equipment be abused, or modified to change its performance beyond the original factory specifications, the warranty will become void and field improvements may be denied.** Setting fuel delivery above specifications or otherwise overpowering machines will result in such action.

Only qualified, experienced operators officially licensed (according to local law) should be allowed to operate the machine. Moreover, only officially licensed personnel should be allowed to inspect and service the machine.

**PRIOR TO OPERATING THIS MACHINE, INCLUDING COMMUNICATION SYSTEM, IN A COUNTRY OTHER THAN A COUNTRY OF ITS INTENDED USE, IT MAY BE NECESSARY TO MAKE MODIFICATIONS TO IT SO THAT IT COMPLIES WITH THE LOCAL REGULATORY STANDARDS (INCLUDING SAFETY STANDARDS) AND LEGAL REQUIREMENTS OF THAT PARTICULAR COUNTRY. PLEASE DO NOT EXPORT OR OPERATE THIS MACHINE OUTSIDE OF THE COUNTRY OF ITS INTENDED USE UNTIL SUCH COMPLIANCE HAS BEEN CONFIRMED. PLEASE CONTACT HITACHI CONSTRUCTION MACHINERY CO., LTD. OR ANY OF OUR AUTHORIZED DISTRIBUTOR OR DEALER IF YOU HAVE ANY QUESTIONS CONCERNING COMPLIANCE.**

All information, illustrations and specifications in this manual are based on the latest product information available at the time of publication. The right is reserved to make changes at any time without notice.

# INTRODUCTION

---

**MEMO**

# INDEX

**MACHINE NUMBERS**

**INTENDED USE**

**SAFETY**

**NAME OF COMPONENTS**

**GETTING ON AND OFF THE MACHINE**

**OPERATOR'S STATION**

**BREAK-IN**

**OPERATING THE ENGINE**

**DRIVING THE MACHINE**

**OPERATING THE MACHINE**

**TRANSPORTING**

**MAINTENANCE**

**MAINTENANCE UNDER SPECIAL ENVIRONMENTAL CONDITIONS**

**STORAGE**

**TROUBLESHOOTING**

**SPECIFICATIONS**

**OPTIONAL ATTACHMENTS AND DEVICES**

**INDEX**

---

---

**MEMO**

---

# CONTENTS

<b>MACHINE NUMBERS .....</b>	<b>1</b>	Prevent Burns .....	S-29
<b>INTENDED USE .....</b>	<b>1</b>	Replace Rubber Hoses Periodically .....	S-29
Intended Use .....	1	Avoid High-Pressure Fluids .....	S-30
<b>SAFETY .....</b>	<b>S-1</b>	Prevent Fires .....	S-31
Recognize Safety Information .....	S-1	Evacuating in Case of Fire .....	S-33
Understand Signal Words .....	S-1	Beware of Exhaust Fumes .....	S-33
Follow Safety Instructions .....	S-2	Precautions for Welding and Grinding .....	S-34
Prepare for Emergencies .....	S-3	Avoid Heating Near Pressurized Fluid Lines .....	S-34
Wear Protective Clothing .....	S-3	Avoid Applying Heat to Lines Containing Flammable Fluids .....	S-34
Protect Against Noise .....	S-4	Precautions for Handling Accumulator and Gas Damper .....	S-35
Inspect Machine .....	S-4	Remove Paint Before Welding or Heating .....	S-35
General Precautions for the Cab .....	S-5	Beware of Asbestos and Silicon Dust and Other Contamination .....	S-36
Use Handholds and Steps .....	S-5	Prevent Battery Explosions .....	S-36
Adjust the Operator's Seat .....	S-6	Handle Chemical Products Safely .....	S-37
Ensure Safety Before Rising from or Leaving Operator's Seat .....	S-6	Dispose of Waste Properly .....	S-37
Fasten Your Seat Belt .....	S-6	Never Ride Attachment .....	S-37
Move and Operate Machine Safely .....	S-7	Precautions for Communication Terminal .....	S-37
Operate Only from Operator's Seat .....	S-7	<b>NAME OF COMPONENTS .....</b>	<b>1-1</b>
Jump Starting .....	S-8	Name of Components .....	1-1
Keep Riders off Machine .....	S-8	<b>GETTING ON AND OFF THE MACHINE .....</b>	<b>1-3</b>
Precautions for Operations .....	S-9	.....	1-3
Investigate Job Site Beforehand .....	S-10	<b>OPERATOR'S STATION .....</b>	<b>1-5</b>
Install OPG Guard .....	S-11	Name of Components .....	1-5
Restriction of Attachment Installation .....	S-11	Name of Components .....	1-6
Provide Signals for Jobs Involving Multiple Machines .....	S-11	Key Switch .....	1-8
Confirm Direction of Machine to Be Driven .....	S-12	Switch Panel .....	1-8
Drive Machine Safely .....	S-13	Monitor Panel .....	1-9
Avoid Injury from Rollaway Accidents .....	S-15	Alternator Indicator .....	1-10
Avoid Injury from Back-Over and Swing Accidents .....	S-16	Fuel Level Indicator .....	1-10
Keep People Clear from Working Area .....	S-17	Preheat Indicator .....	1-10
Never Position the Bucket Over Anyone .....	S-17	Overheat Indicator .....	1-11
Avoid Undercutting .....	S-18	Engine Oil Pressure Indicator .....	1-11
Avoid Tipping .....	S-18	Hour Meter .....	1-11
Never Undercut a High Bank .....	S-19	Fuel Gauge .....	1-11
Dig with Caution .....	S-19	Coolant Temperature Indicator .....	1-11
Operate with Caution .....	S-19	Using the Heater (ZX26U-6) (Cab equipped machine) .....	1-12
Avoid Power Lines .....	S-20	Cab Heater Operation (ZX26U-6) (Cab Equipped Machine) .....	1-12
Precautions for Lightning .....	S-20	Radio (ZX26U-6) (Cab equipped machine) (Optional) .....	1-13
Lifting Application .....	S-21	AM/FM Radio Operation (Cab equipped machine) .....	1-14
Protect Against Flying Debris and Falling Object ... .....	S-22	Part Name and Function .....	1-14
Park Machine Safely .....	S-23	Radio Operation .....	1-14
Handle Fluids Safely—Avoid Fires .....	S-23	Tuning Procedure .....	1-15
Transport Safely .....	S-24	Station Presetting Procedure .....	1-15
Practice Safe Maintenance .....	S-25	Deletion of Preset Memory .....	1-15
Warn Others of Service Work .....	S-26	Sound Adjustment .....	1-16
Support Machine Properly .....	S-27		
Stay Clear of Moving Parts .....	S-27		
Prevent Parts from Flying .....	S-28		
Avoid Injury from Attachment Falling Accident .....	S-28		

# CONTENTS

Digital Clock Setting Procedure .....	1-16	Never Swing the Machine or Boom to Work.....	5-12
Door Lock Release Lever (ZX26U-6) (Cab equipped machine) .....	1-17	Avoid Driving Bucket Teeth into Ground .....	5-12
Using the Front Window (ZX26U-6) (Cab equipped machine) .....	1-18	Never use as a Hammer .....	5-13
Front Window .....	1-18	Boom Cylinder may Hit Blade.....	5-13
Removing and Storing Lower Front Window .... .....	1-18	Avoid Hitting Blade With Bucket.....	5-14
Adjusting the Seat .....	1-19	Avoid Colliding Blade Against Rocks .....	5-14
Operator's Seat Fore-Aft Adjustment .....	1-19	Avoid Colliding Boom Cylinder With Track.....	5-14
Seat Back Box .....	1-19	Precautions for Installing Wide Bucket or Special Type Bucket .....	5-15
Escaping from the Emergency Exit (ZX26U-6) (Cab equipped machine) .....	1-20	Use the Right Shoes for the Site .....	5-15
Seat Belt .....	1-21	Using Rubber Crawler .....	5-16
Seat Belt.....	1-21	Never Use Other than as Specified .....	5-18
Room Lamp (ZX26U-6) (Cab equipped machine) .. .....	1-22	Using the Towing Bracket on the Track Frame .....	5-19
Battery Disconnect Switch .....	1-23	Lowering the Boom in Emergencies and if the Engine Stops .....	5-20
Switch Operation .....	1-24	Precautions for After Operations .....	5-23
<b>BREAK-IN .....</b>	<b>2-1</b>	<b>TRANSPORTING .....</b>	<b>6-1</b>
Breaking in New Machine .....	2-1	Transporting by Road.....	6-1
<b>OPERATING THE ENGINE .....</b>	<b>3-1</b>	Loading/Unloading on a Truck.....	6-1
Inspect Machine Daily Before Starting.....	3-1	Lifting the Machine .....	6-7
Before Starting the Engine .....	3-2	<b>MAINTENANCE.....</b>	<b>7-1</b>
Starting the Engine .....	3-3	Correct Maintenance and Inspection Procedures .. .....	7-1
Check Instruments After Starting Engine .....	3-5	Check the Hour Meter Regularly .....	7-1
Using Booster Battery.....	3-6	Name of Components.....	7-2
Stopping the Engine.....	3-8	Maintenance Guide Table .....	7-3
<b>DRIVING THE MACHINE .....</b>	<b>4-1</b>	Preparation for Inspection and Maintenance.....	7-6
Travel Lever (ZX17U-6, 19U-6) .....	4-1	Access Covers .....	7-7
Travel Levers and Pedals (ZX26U-6) .....	4-3	Opening and Closing the Engine CoverZX17U-6, 19U-6.....	7-7
Travel Mode Pedal (ZX17U-6, 19U-6) .....	4-5	Opening and Closing the Engine CoverZX26U-6.....	7-9
Travel Mode Switch (ZX26U-6) .....	4-6	Opening and Closing the Tank CoverZX17U-6,19U-6.....	7-11
Traveling.....	4-7	Opening and Closing the Tank CoverZX26U-6... .....	7-12
Traveling on Soft Ground.....	4-8	Opening and Closing Radiator Front Cover.....	7-13
Raising One Track Using the Boom and Arm .....	4-8	Opening and Closing Radiator Front Cover.....	7-14
Towing the Machine .....	4-9	Maintenance Guide.....	7-15
Operating in Water or Mud .....	4-10	Periodic Replacement of Parts.....	7-19
Precautions for Traveling on Slopes .....	4-11	Kind of Oils .....	7-20
Parking the Machine on Slopes .....	4-13	List of Consumable Parts.....	7-23
Parking .....	4-13	A. Greasing .....	7-24
<b>OPERATING THE MACHINE.....</b>	<b>5-1</b>	Front Joint Pins.....	7-24
Control Lever (ISO Pattern) .....	5-1	Blade Pins (ZX26U-6).....	7-26
Boom Swing Pedal.....	5-2	Swing Bearing.....	7-27
Blade Lever .....	5-3	Swing Internal Gear .....	7-28
Precautions for Blade Operation .....	5-4	Control Lever Universal Joint .....	7-29
Side Frame Extend/Retract Lever (ZX17U-6, 19U-6) .....	5-5	B. Engine .....	7-30
Pilot Control Shut-Off Lever .....	5-7	Check Engine Oil Level .....	7-30
Warming-Up Operation.....	5-9	Change Engine Oil .....	7-31
Operating Backhoe .....	5-10	Replace Engine Oil Filter .....	7-31
Grading Operation .....	5-11	C. Transmission .....	7-34
Avoid Abusive Operation.....	5-12	Gear Oil in Travel Reduction Gear .....	7-34



# CONTENTS

D. Hydraulic System .....	7-36	Working Ranges ZX26U-6.....	12-6
Check Hydraulic Oil Level .....	7-39	Bucket Types and Applications.....	12-7
Drain Hydraulic Oil Tank Sump.....	7-40	ZX17U-6 .....	12-7
Change Hydraulic Oil .....	7-41	ZX19U-6 .....	12-8
Cleaning the Suction Filter .....	7-41	ZX26U-6 .....	12-9
Replace Full-Flow Filter .....	7-47	Noise Level Results(2000/14/EC)(2006/42/EC).....	12-10
Replace Pilot Oil Filter Element .....	7-50	Electric Fans .....	12-10
Check Hoses and Lines .....	7-53	The Value of the Carbon Dioxide (CO <sub>2</sub> ) Emissions..	
E. Fuel System.....	7-58	.....	12-10
Check Fuel Level .....	7-59	Lifting Capacities and Machine Capacities.....	12-11
Check Water Separator.....	7-60	Lifting Capacities .....	12-12
Drain Fuel Tank Sump.....	7-62	Machine Capacities.....	12-14
Replace Fuel Main Filter Element .....	7-63		
Check Fuel Hoses.....	7-64	<b>OPTIONAL ATTACHMENTS AND DEVICES.</b>	
F. Air Cleaner .....	7-65	.....	<b>13-1</b>
Clean and Replace Air Cleaner Element.....	7-65	Hydraulic Breaker, Hydraulic Crusher and Quick	
G. Cooling System.....	7-66	Couple .....	13-1
Check Coolant Level.....	7-67	Selecting a breaker or crusher.....	13-1
Check and Adjust Fan Belt Tension .....	7-68	Precautions for Operation.....	13-1
Change Coolant .....	7-71	Precautions for connecting breaker, crusher or	
Clean Radiator/Oil Cooler Core .....	7-73	quick coupler piping.....	13-1
H. Electrical System .....	7-74	Attachment.....	13-2
Battery .....	7-75	Allowable Weight Limits of Installed	
Replacement of Fuses.....	7-80	Attachments .....	13-2
I. Miscellaneous .....	7-81	Piping for Breaker and Crusher .....	13-3
Check and Replace Bucket Teeth .....	7-81	Operational Procedures for Stop and Selection	
Change Bucket .....	7-83	Valves .....	13-3
Adjust Track Sag (Rubber Crawler) and Check		Pedal Operation and Hydraulic Oil Flow .....	13-4
for Damage .....	7-84	Attachment Pedal (Hydraulic Breaker) (Optional)..	
Replace Rubber Crawler.....	7-86	.....	13-5
Check and Replace Seat Belt .....	7-88	Precautions for Breaker Operation .....	13-6
Clean Cab Floor (ZX26U-6) (Cab equipped		Attachment Pedal (Hydraulic Crusher) (Optional) ..	
machine) .....	7-88	.....	13-10
Check, Clean and Function Check of Injection		Precautions for Crusher Operation.....	13-11
Nozzle.....	7-89	AUX Function Lever for Extra Piping 1 (Optional) ...	
Inspect and Adjust Valve Clearance .....	7-89	.....	13-13
Check and Adjust Injection Timing.....	7-89	Numeric Keypad Lock (Optional) .....	13-14
Measure Engine Compression Pressure .....	7-89		
Check Starter and Alternator .....	7-89	<b>INDEX.....</b>	<b>15-1</b>
Check Crankcase Breather.....	7-90		
Check Radiator Cap .....	7-90		
Tightening and Retightening Torque of Bolts			
and Nuts.....	7-91		
<b>MAINTENANCE UNDER SPECIAL</b>			
<b>ENVIRONMENTAL CONDITIONS.....</b>	<b>9-1</b>		
<b>STORAGE .....</b>	<b>10-1</b>		
<b>TROUBLESHOOTING.....</b>	<b>11-1</b>		
<b>SPECIFICATIONS .....</b>	<b>12-1</b>		
Specifications ZX17U-6.....	12-1		
Specifications ZX19U-6.....	12-2		
Specifications ZX26U-6.....	12-3		
Working Ranges ZX17U-6.....	12-4		
Working Ranges ZX19U-6.....	12-5		

---

---

**MEMO**

---

# MACHINE NUMBERS

The manufacturing Nos. explained in this group is the individual number (serial No.) given to each machine and main components. These numbers are requested when inquiring any information on the machine and/or components. Fill these serial Nos. in the blank spaces in this group to immediately make them available upon request.

## Machine

<b>CE</b>	<b>HITACHI</b>	
Model/type	1	
Product Identification Number	2	
Manufactured in	3	
Engine Power(kW)	4	Mass(kg) <span style="text-align: center;">5</span>
Manufacturer	6	

MADR-00-002-1 ja

1. MODEL/TYPE
2. Product Identification Number
3. Manufactured in
4. Engine power in kW according to ISO14396 ; 2002
5. Operating mass (No additional counter weight version)
6. Manufacturer (Authorized Representative, if applicable)

## Product Identification Number

 **NOTE**

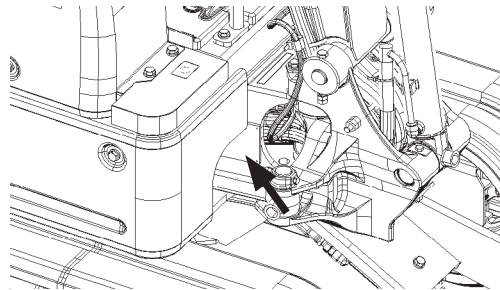
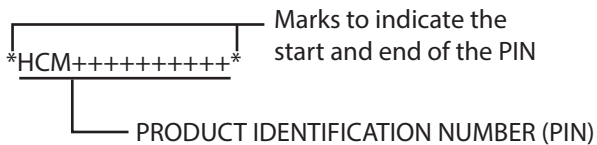

ZX17U-6,19U-6

MABK-00-036-1 ja

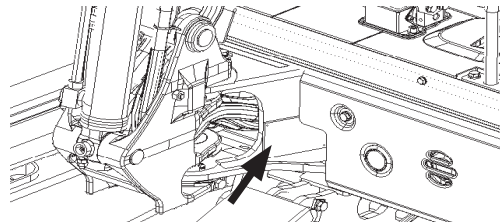

ZX26U-6

MABK-00-037-1 ja

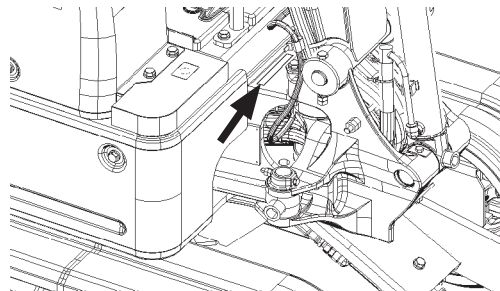

ZX17U-6,19U-6

MABK-00-036-2 ja

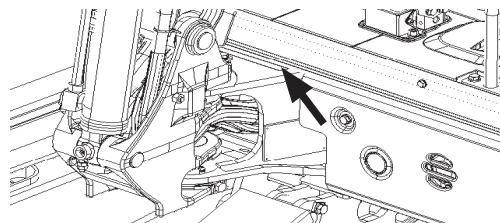

ZX26U-6

MABK-00-037-2 ja

# MACHINE NUMBERS

---

## Engine

TYPE :  
MFG. NO. :

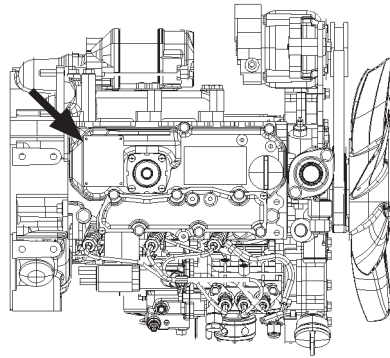

ZX17U-6,19U-6

MABK-00-028-1 ja

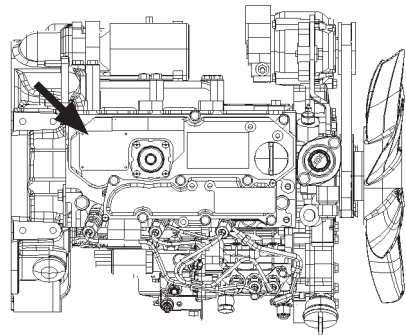

ZX26U-6

MABK-00-029-1 ja

# MACHINE NUMBERS

---

## Transmission

TYPE :  
MFG. NO. :

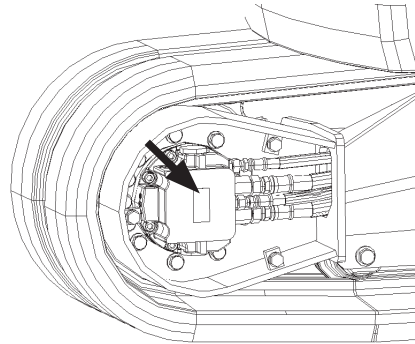

ZX17U-6,19U-6

MABK-00-030-1 ja

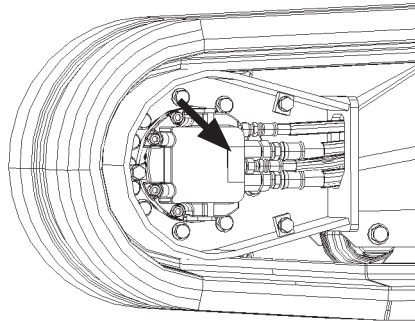

ZX26U-6

MABK-00-031-1 ja

## MACHINE NUMBERS

---

### Swing Motor

TYPE :  
MFG. NO. :

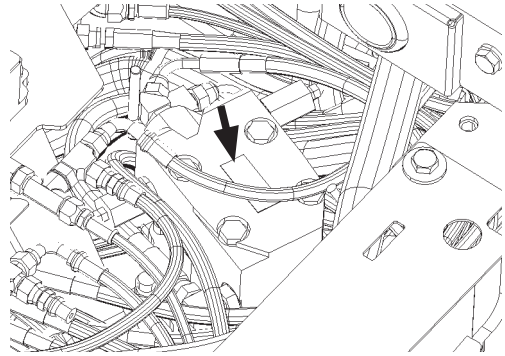

ZX17U-6,19U-6

MABK-00-032-1 ja

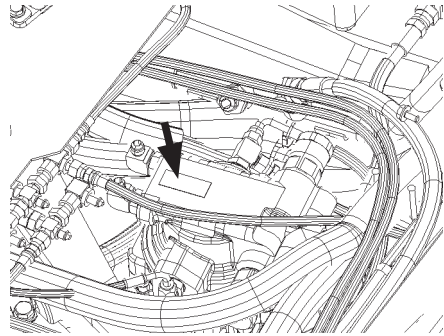

ZX26U-6

MABK-00-033-1 ja

## MACHINE NUMBERS

---

### Hydraulic Pump

TYPE :  
MFG. NO. :

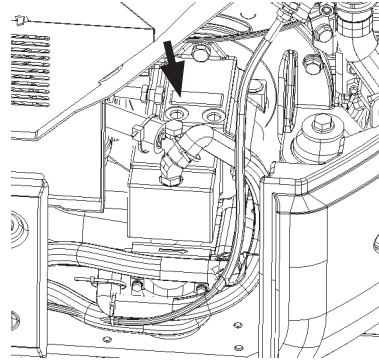

ZX17U-6,19U-6

MABK-00-034-1 ja

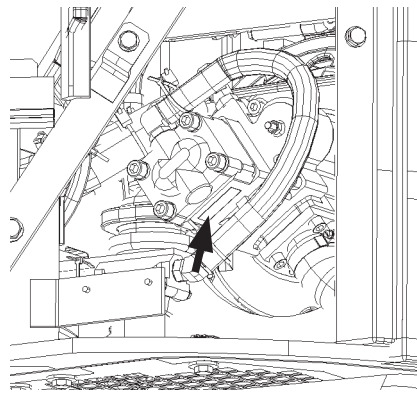

ZX26U-6

MABK-00-035-1 ja

## MACHINE NUMBERS

---

---

MEMO



## INTENDED USE

---

### **Intended Use**

This machine is designed and intended to be used for excavating with a bucket or working with tools/attachments described in this manual or approved in writing by the manufacturer.

Risk assessment related to the specific application and working conditions of the machine may require additional safety measures such as protective guards, safety glazing, filtration of cabin air, etc. to be installed, enabling the machine to be operated safely under the specific conditions. Consult your authorized dealer for further information on possibilities to adapt the machine accordingly.

## INTENDED USE

---

---

**MEMO**

# SAFETY

## Recognize Safety Information

- These are the **SAFETY ALERT SYMBOLS**.
  - When you see these symbols on your machine or in this manual, be alert to the potential for personal injury.
  - Follow recommended precautions and safe operating practices.



SA-2644 ja

## Understand Signal Words

- On machine safety signs, signal words designating the degree or level of hazard - **DANGER**, **WARNING**, or **CAUTION** are used with the safety alert symbol.
  - **DANGER** indicates an imminently hazardous situation which, if not avoided, will result in death or serious injury.
  - **WARNING** indicates a potentially hazardous situation which, if not avoided, could result in death or serious injury.
  - **CAUTION** indicates a potentially hazardous situation which, if not avoided, may result in minor or moderate injury.
  - **DANGER or WARNING safety signs** are located near specific hazards. General precautions are listed on **CAUTION safety signs**.
  - Some safety signs are occasionally used on this machine that do not use any of the designated signal words mentioned above after the safety alert symbol.
- To avoid confusing machine protection with personal safety messages, a signal word **IMPORTANT** indicates a situation which, if not avoided, could result in damage to the machine.
-  **NOTE**: Indicates an additional explanation for a piece of information.



SA-632 en\_GB

# SAFETY

---

## Follow Safety Instructions

- Carefully read and follow all safety signs on the machine and all safety messages in this manual.
- Safety signs should be installed, maintained and replaced when necessary.
  - If a safety sign or this manual is damaged or missing, order a replacement from your authorized dealer in the same way you order other replacement parts (be sure to state machine model and serial number when ordering).
- Learn how to operate the machine and its controls correctly and safely.
- Allow only trained, qualified, authorized personnel to operate the machine.
- Keep your machine in proper working condition.
  - Unauthorized modifications of the machine may impair its function and/or safety and affect machine life.
  - Do not modify any machine parts without authorization. Failure to do so may deteriorate the safety, function, and/or service life of the part. In addition, personal accident, machine trouble, and/or damage to material caused by unauthorized modifications will void Hitachi Warranty Policy.
  - Do not use attachments and/or optional parts or equipment not authorized by Hitachi. Failure to do so may deteriorate the safety, function, and/or service life of the machine. In addition, personal accident, machine trouble, and/or damage to material caused by using unauthorized attachments and/or optional parts or equipment will void Hitachi Warranty Policy.
- The safety messages in this SAFETY chapter are intended to illustrate basic safety procedures of machines. However it is impossible for these safety messages to cover every hazardous situation you may encounter. If you have any questions, you should first consult your supervisor and/ or your authorized dealer before operating or performing maintenance work on the machine.

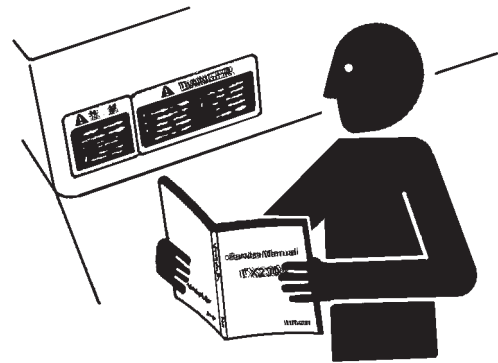

SA-003 ja

## SAFETY

### Prepare for Emergencies

- Be prepared for a fire or an accident.
  - Keep a first aid kit and fire extinguisher on hand.
  - Thoroughly read and understand the label attached on the fire extinguisher to use it properly.
  - To ensure that a fire extinguisher can be always used when necessary, check and service the fire extinguisher at the recommended intervals as specified in the fire extinguisher manual.
  - Establish emergency procedure guidelines to cope with fires and accidents.
  - Keep emergency numbers for doctors, ambulance service, hospital, and fire department posted near your telephone.



SA-437 ja

### Wear Protective Clothing

- Wear close fitting clothing and safety equipment appropriate to the job.

You may need:

- A hard hat
- Safety belt
- Safety shoes
- Safety glasses, goggles, or face shield
- Heavy gloves
- Hearing protection
- Reflective clothing
- Wet weather gear
- Respirator or filter mask

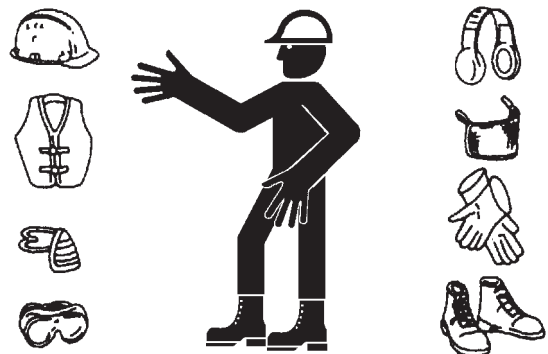

SA-438 ja

Be sure to wear the correct equipment and clothing for the job. Do not take any chances.

- Avoid wearing loose clothing, jewelry, or other items that can catch on control levers or other parts of the machine.
- Operating equipment safely requires the full attention of the operator. Do not wear radio or music headphones while operating the machine.

## SAFETY

---

### Protect Against Noise

- Prolonged exposure to loud noise can cause impairment or loss of hearing.
  - Wear a suitable hearing protective device such as earmuffs or earplugs to protect against objectionable or uncomfortably loud noises.



SA-434 ja

---

### Inspect Machine

- Inspect your machine carefully each day or shift by walking around it before you start it to avoid personal injury.
  - In the walk-around inspection be sure to cover all points described in the "Inspect Machine Daily Before Starting" section in the operator's manual.



SA-435 ja

# SAFETY

---

## General Precautions for the Cab

- Always keep inside the cab clean by observing instructions below, to prevent any personal accidents from occurring.
  - Before entering the cab, thoroughly remove all dirt and/or oil such as mud, grease, soil or stones from the soles of your work boots. If any controls such as a pedal is operated while with dirt and/or oil on the soles of the operator's work boots, the operator's foot may slip off the pedal, possibly resulting in a personal accident.
  - Do not mess up around the operator's seat with parts, tools, soil, stones, obstacles that may fold up or turn over, cans or lunch box. The levers or pedals become inoperable if obstacle jams in operation stroke of the travel levers/pedals, pilot control shut-off lever or control levers, which may result in serious injury or death.
  - Avoid storing transparent bottles in the cab. Do not attach any transparent type window decorations on the windowpanes as they may focus sunlight, possibly starting a fire.
  - Refrain from listening to the radio, or using music headphones or mobile telephones in the cab while operating the machine.
  - Keep all flammable materials and/or explosives away from the machine.
  - After using the ashtray, always cover it to extinguish the match and/or tobacco.
  - Do not leave cigarette lighters in the cab. When the temperature in the cab increases, the lighter may explode.
  - Correctly lay the floor mat specific to the machine. If another floor mat is used, it may be displaced and contact with the travel pedals during operation, resulting in serious injury or death.

---

## Use Handholds and Steps

- Falling is one of the major causes of personal injury.
  - When you get on and off the machine, always use the crawler instead of the step for safety. Also get on and off from the position of the crawler that can secure your feet space enough.
  - When you get on and off the machine, always face the machine.
  - Maintain a three-point contact with the steps and handrails.
  - Do not use any controls as handholds.
  - Never jump on or off the machine. Never mount or dismount a moving machine.
  - In case adhered slippery material such as oil, grease, or mud is present on steps, handrails, or platforms, thoroughly remove such material.
  - Do not get on or off the machine while holding something, such as a tool, in your hands.



SA-439 ja

## SAFETY

---

### Adjust the Operator's Seat

- A seat which is poorly adjusted for the individual operator, or the work to be undertaken, may quickly fatigue the operator leading to misoperation.
  - The seat should be adjusted whenever the operator of the machine changes.
  - The operator should be able to fully depress the pedals and to correctly operate the control levers with his back against the seat back.
  - If not, move the seat forward or backward, and check again.
  - Adjust the rear view mirror position so that the best rear visibility is obtained from the operator's seat. If the mirror is broken, immediately replace it with a new one.



SA-378 ja

---

### Ensure Safety Before Rising from or Leaving Operator's Seat

- Before rising from the operator's seat to open/close either side window or to adjust the seat position, be sure to first lower the front attachment to the ground and then move the pilot control shut-off lever to the LOCK position. Failure to do so may allow the machine to unexpectedly move when a body part unintentionally comes in contact with a control lever and/or pedal, possibly resulting in serious personal injury or death.
- Before leaving the machine, be sure to first lower the front attachment to the ground and then move the pilot control shut-off lever to the LOCK position. Turn the key switch OFF to stop the engine.
- Before leaving the machine, close all windows, doors, and access covers and lock them.

---

### Fasten Your Seat Belt

- If the machine should overturn, the operator may become injured and/or thrown from the cab. Additionally the operator may be crushed by the overturning machine, resulting in serious injury or death.
  - Prior to operating the machine, thoroughly examine webbing, buckle and attaching hardware. If any item is damaged or worn, replace the seat belt or component before operating the machine.
  - Be sure to remain seated with the seat belt securely fastened at all times when the machine is in operation to minimize the chance of injury from an accident.
  - We recommend that the seat belt is replaced every three years regardless of its apparent condition.



SA-237 ja



## SAFETY

### Move and Operate Machine Safely

- Bystanders can be run over.
  - Take extra care not to run over bystanders. Confirm the location of bystanders before moving, swinging, or operating the machine.
  - Always keep the travel alarm and horn in working condition (if equipped). It warns people when the machine starts to move.
  - Use a signal person when moving, swinging, or operating the machine in congested areas. Coordinate hand signals before starting the machine.
  - Use appropriate illumination. Check that all lights are operable before operating the machine. If any faulty illumination is present, immediately repair it.
  - Ensure the cab door, windows, doors and covers are securely locked.
  - Check the mirrors in the cab for problems. If there is, replace the problem part (s) or clean the mirror.



SA-1291 ja

### Operate Only from Operator's Seat

- Inappropriate engine starting procedures may cause the machine to runaway, possibly resulting in serious injury or death.
  - Start the engine only when seated in the operator's seat.
  - Never start the engine while standing on the track or ground.
  - Do not start engine by shorting across starter terminals.
  - Before starting the engine, confirm that all control levers are in neutral.
  - Before starting the engine, confirm the safety around the machine and sound the horn to alert bystanders.



SA-444 ja

## SAFETY

---

### Jump Starting

- Battery gas can explode, resulting in serious injury.
  - If the engine must be jump started, be sure to follow the instructions shown in the "OPERATING THE ENGINE" chapter in the operator's manual.
  - The operator must be in the operator's seat so that the machine will be under control when the engine starts. Jump starting is a two-person operation.
  - Never use a frozen battery.
  - Failure to follow correct jump starting procedures could result in a battery explosion or a runaway machine.



SA-032 ja

---

### Keep Riders off Machine

- Riders on machine are subject to injury such as being struck by foreign objects and being thrown off the machine.
  - Only the operator should be on the machine. Keep riders off.
  - Riders also obstruct the operator's view, resulting in the machine being operated in an unsafe manner.



SA-1292 ja

## SAFETY

---

### Precautions for Operations

- Investigate the work site before starting operations.
  - Be sure to wear close fitting clothing and safety equipment appropriate for the job, such as a hard hat, etc. when operating the machine.
  - Keep bystanders and obstacles clear of the area of machine operation.  
Keep persons other than the operator away from areas where there is danger, such as from flying objects.  
Always be aware of the surroundings while operating.  
When working in a small area surrounded by obstacles, take care not to hit the upperstructure against obstacles.
- When loading onto trucks, bring the bucket over the truck beds from the rear side. Take care not to swing the bucket over the cab or over any person.

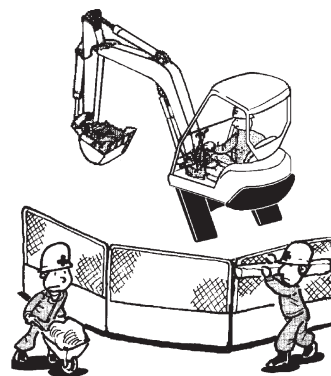

M586-12-012 ja

# SAFETY

## Investigate Job Site Beforehand

- When working at the edge of an excavation or on a road shoulder, the machine could tip over, possibly resulting in serious injury or death.
  - Investigate the configuration and ground conditions of the job site beforehand to prevent the machine from falling and to prevent the ground, stockpiles or banks from collapsing.
  - Make a work plan. Use machines appropriate to the work and job site.
  - Reinforce ground, edges and road shoulders as necessary. Keep the machine well back from the edges of excavations and road shoulders.
  - When working on an incline or on a road shoulder, employ a signal person as required.
  - Confirm that your machine is equipped with a FOPS cab before working in areas where the possibility of falling stones or debris exist.
  - When the ground footing is weak, reinforce the ground before starting work.
  - When working on frozen ground, be extremely alert. As ambient temperatures rise, footing becomes loose and slippery.
  - Beware the possibility of fire when operating the machine near flammable materials such as dry grass.
  - Make sure the worksite has sufficient strength to firmly support the machine.  
When working close to an excavation or at road shoulders, operate the machine with the tracks positioned perpendicular to the cliff face with travel motors at the rear, so that the machine can more easily evacuate if the cliff face collapses.
  - If working on the bottom of a cliff or a high bank is required, be sure to investigate the area first and confirm that no danger of the cliff or bank collapsing exists. If any possibility of cliff or bank collapsing exists, do not work on the area.
  - Soft ground may collapse when the machine is operated on it, possibly causing the machine to tip over. When working on soft ground is required, be sure to reinforce the ground first using steel plates strong and firm enough to easily support the machine.
  - Note that there is always a possibility of machine tipping over when working on rough terrain or on slopes. Prevent machine tipping over from occurring. When operating on rough terrain or on slopes:
    - Reduce the engine speed.
    - Select slow travel speed mode.
    - Operate the machine slowly and be cautious with machine movements.

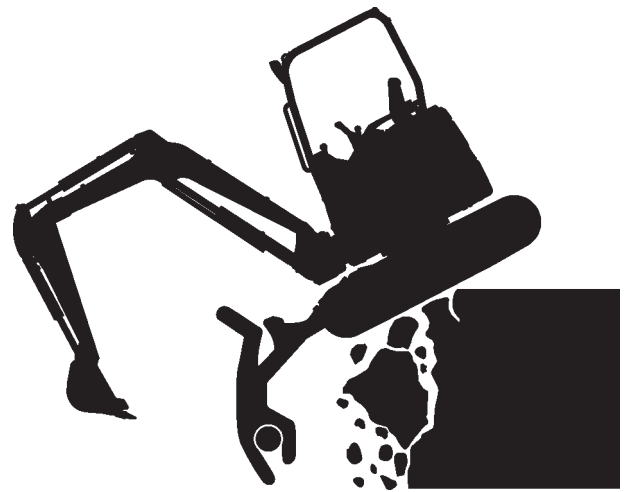

SA-1293 ja

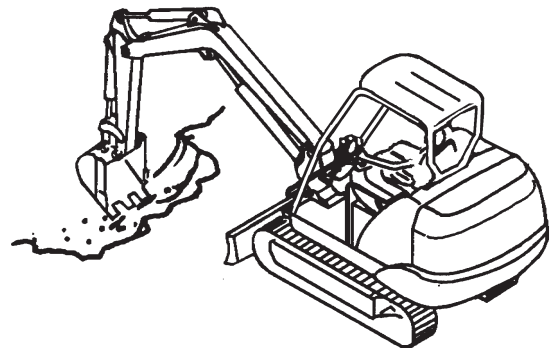

M586-05-021 ja

## SAFETY

---

### Install OPG Guard

- In case the machine is operated in areas where the possibility of falling stones or debris exists, equip genuine Hitachi OPG guard. Contact your nearest Hitachi dealer for installation method of the OPG guard. Depending on the specifications applied to your machine, modification of the machine to meet ROPS standards will be possible.
- To maintain unimpaired operator protection and manufacturer's protective structure.
  - Damaged ROPS, OPG guard must be replaced, not repaired or revised.
  - Any alternation to the ROPS or OPG guard must be approved by the manufacturer.

ROPS : Roll Over Protective Structure

OPG : Operator Protective Guard

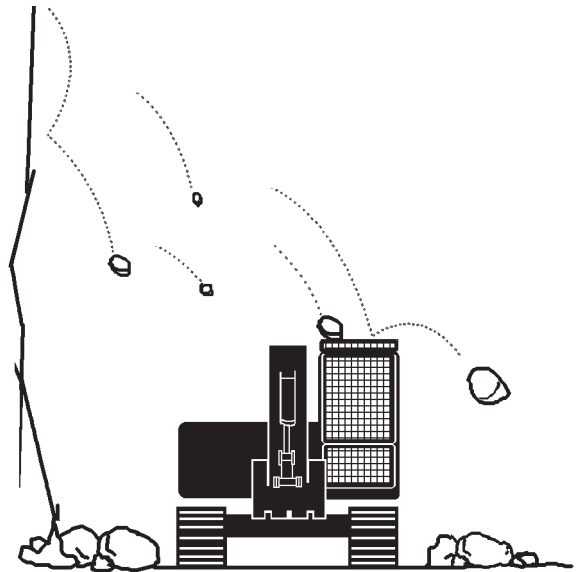

SA-490 ja

---

### Restriction of Attachment Installation

Do not install an attachment which exceeds the specified weight for the machine structure.

---

### Provide Signals for Jobs Involving Multiple Machines

- In case more than one machine is operated in the same job site, accidental collision between machines may cause serious injury or death.
- For jobs involving multiple machines, provide signals commonly known by all personnel involved. Also, appoint a signal person to coordinate the job site. Make sure that all personnel obey the signal person's directions.



SA-481 ja

## SAFETY

---

### Confirm Direction of Machine to Be Driven

- Incorrect travel pedal/lever operation may result in serious injury or death.
  - Before driving the machine, confirm the position of the undercarriage in relation to the operator's position. If the travel motors are located in front of the cab, the machine will move in reverse when travel pedals/levers are operated facing forwards.

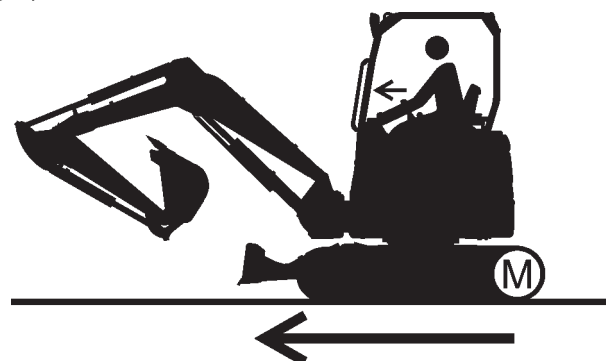

SA-1294 ja

# SAFETY

## Drive Machine Safely

- Before driving the machine, always confirm that the travel levers/pedals direction corresponds to the direction you wish to drive.
  - Be sure to detour around any obstructions.
  - Avoid traveling over obstructions. Soil, fragments of rocks, and/or metal pieces may scatter around the machine. Do not allow personnel to stay around the machine while traveling.
- Driving on a slope may cause the machine to slip or overturn, possibly resulting in serious injury or death.
  - Never attempt to ascend or descend 25 degrees or steeper slopes.
  - Be sure to fasten the seat belt.
  - When driving up or down a slope, keep the bucket facing the direction of travel, approximately 200 to 300 mm (see A on the right) above the ground.
  - If the machine starts to skid or becomes unstable, immediately lower the bucket to the ground and stop.
  - Driving across the face of a slope or steering on a slope may cause the machine to skid or turnover. If the direction must be changed, move the machine to level ground, then, change the direction to ensure safe operation.
- Avoid swinging the upperstructure on slopes. Never attempt to swing the upperstructure downhill. The machine may tip over. If swinging uphill is unavoidable, carefully operate the upperstructure and boom at slow speed.
- If the engine stalls on a slope, immediately lower the bucket to the ground. Return the control levers to neutral. Then, restart the engine.
- Be sure to thoroughly warm up the machine before ascending steep slopes. If hydraulic oil has not warmed up sufficiently, sufficient performance may not be obtained.
- Use a signal person when moving, swinging or operating the machine in congested areas. Coordinate hand signals before starting the machine.

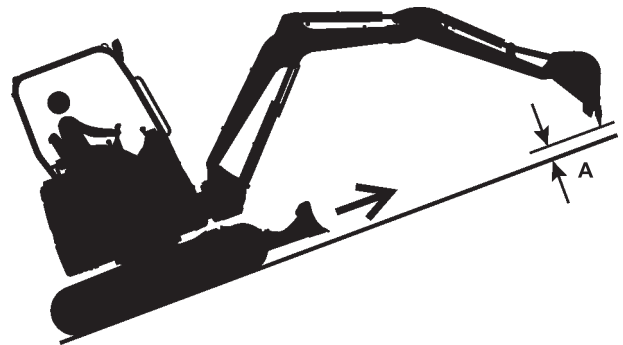

SA-1295-1 ja



SA-1296-1 ja

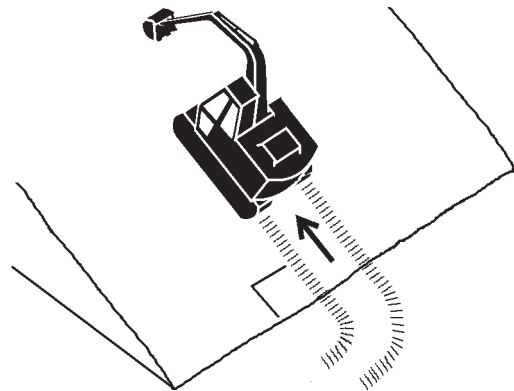

SA-441 ja

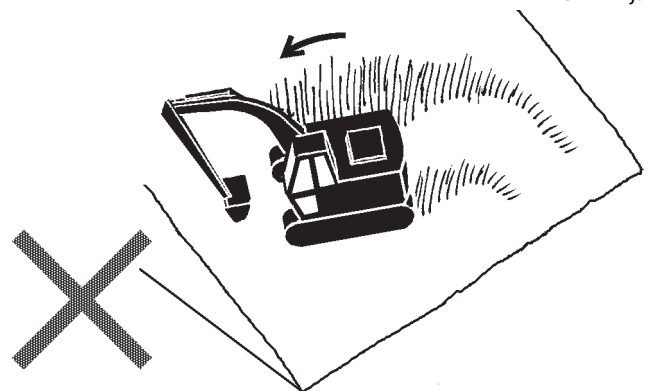

SA-442 ja

## SAFETY

- When the machine descends a slope at high speed, machine weight accelerates descending speed. It may cause collision accident due to misjudging of braking distance or machine turnover due to running on an unexpected obstacle. Before descending a slope, always ensure that engine control lever (1) is in the slow idle position, and then reduce the engine speed. Turn the travel mode switch (2) to slow speed for ZX26U-6.
- Select a travel route that is as flat as possible. Steer the machine as straight as possible, making small gradual changes in direction.
- Before traveling on them, check the strengths of bridges and road shoulders, and reinforce if necessary.
- Use wood plates in order not to damage the road surface. Be careful of steering when operating on asphalt roads in summer.
- When crossing train tracks, use wood plates in order not to damage them.
- Do not make contact with electric wires or bridges.
- When crossing a river, measure the depth of the river using the bucket, and cross slowly. Do not cross the river when the depth of the river is deeper than the upper edge of the upper roller.
- When traveling on rough terrain, reduce engine speed. Select slow travel speed. Slower speed will reduce possible damage to the machine.
- Avoid operations that may damage the track and undercarriage components.
- During freezing weather, always clean snow and ice from track shoes before loading and unloading the machine, to prevent the machine from slipping.

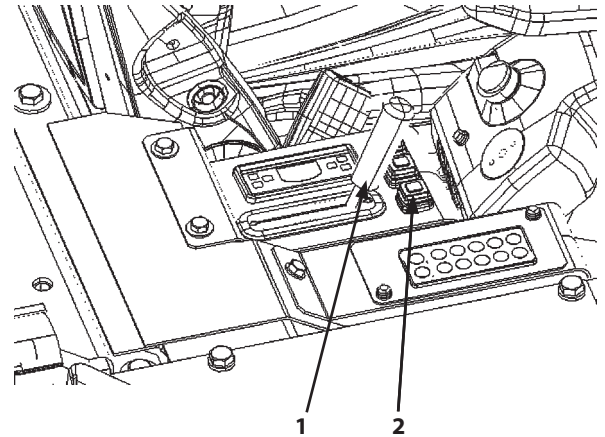

MABA-04-003-3 ja

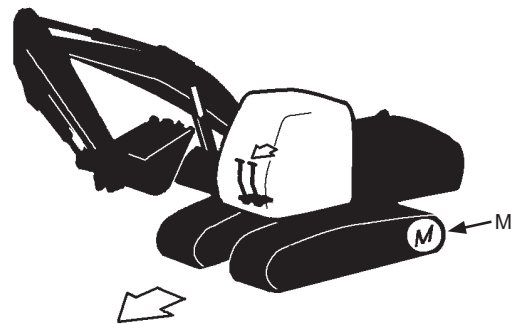

M104-05-008-2 ja

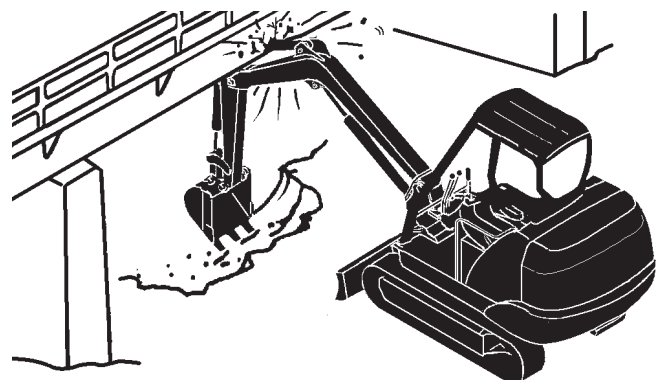

SA-673 ja

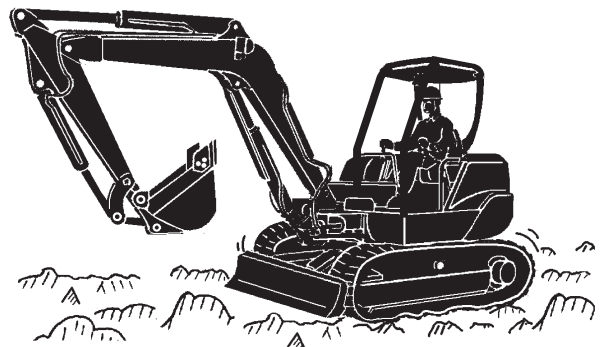

M586-05-002 ja



## SAFETY

---

### Avoid Injury from Rollaway Accidents

- Death or serious injury may result if you attempt to mount or try to bodily stop a moving machine.
- Park the machine in compliance with the safe parking procedures described on page "Park Machine Safely" to prevent the machine from running away.
  - Block both tracks and lower the bucket to the ground, thrust the bucket teeth into the ground if you must park on a grade.
  - Park at a reasonable distance from other machines.

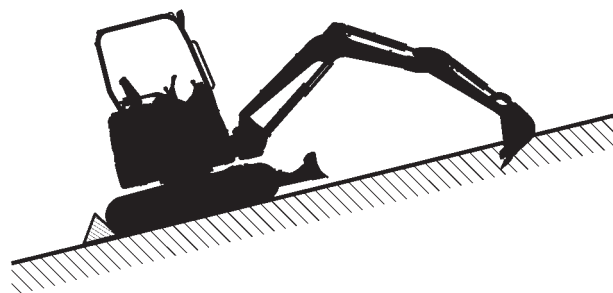

SA-1297 ja

## SAFETY

---

### Avoid Injury from Back-Over and Swing Accidents

- If any person is present near the machine when backing or swinging the upperstructure, the machine may hit or run over that person, resulting in serious injury or death. To avoid back-over and swing accidents:
  - Always look around BEFORE YOU BACK UP AND SWING THE MACHINE. BE SURE THAT ALL BYSTANDERS ARE CLEAR.
  - Keep the travel alarm in working condition (if equipped). ALWAYS BE ALERT FOR BYSTANDERS MOVING INTO THE WORK AREA. USE THE HORN OR OTHER SIGNAL TO WARN BYSTANDERS BEFORE MOVING MACHINE.
  - USE A SIGNAL PERSON WHEN BACKING UP IF YOUR VIEW IS OBSTRUCTED. ALWAYS KEEP THE SIGNAL PERSON IN VIEW. Use hand signals, which conform to your local regulations, when work conditions require a signal person.
  - No machine motions shall be made unless signals are clearly understood by both signal person and operator.
  - Learn the meanings of all flags, signs, and markings used on the job and confirm who has the responsibility for signaling.
  - Keep windows, mirrors, and lights clean and in good condition.
  - Dust, heavy rain, fog, etc., can reduce visibility. As visibility decreases, reduce speed and use proper lighting.
  - Read and understand all operating instructions in the operator's manual.

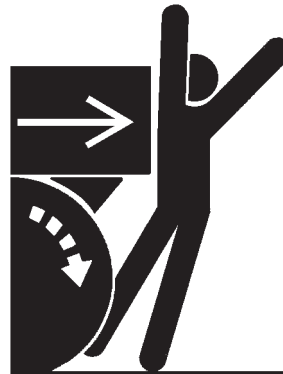

SA-383 ja

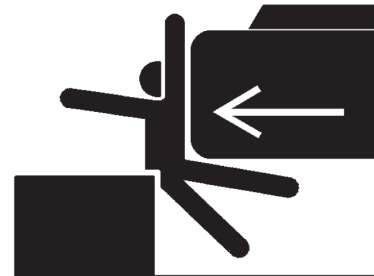

SA-384 ja

## SAFETY

---

### Keep People Clear from Working Area

- People around the operating machine may be hit severely by the swinging front attachment or counterweight, be caught in other objects, and/or be struck by flying objects, resulting in serious injury or death.
- Set up barriers and/or put a "NO ADMISSION" sign at the machine operating site and areas exposed by flying objects to prevent anyone from entering the work area.
- Before operating the machine, set up barriers to the sides and rear area of the bucket swing radius to prevent anyone from entering the work area.

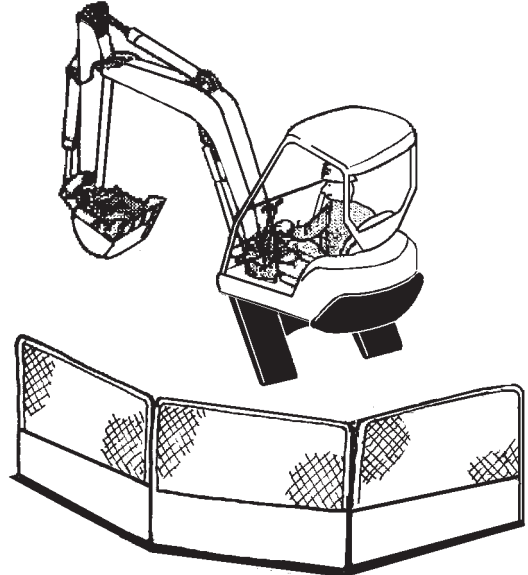

SA-667 ja

---

### Never Position the Bucket Over Anyone

- Never lift, move, or swing the bucket above anyone or above the truck cab. Serious injury or machine damage may result due to bucket load spill or due to collision with the bucket.



SA-668 ja

## SAFETY

### Avoid Undercutting

- In order to retreat from the edge of an excavation if the footing should collapse, always position the undercarriage perpendicular to the edge of the excavation with the travel motors at the rear.
- If the footing starts to collapse and if retreat is not possible, do not raise the front attachment in a panic. Lowering the front attachment may be safer in most cases.

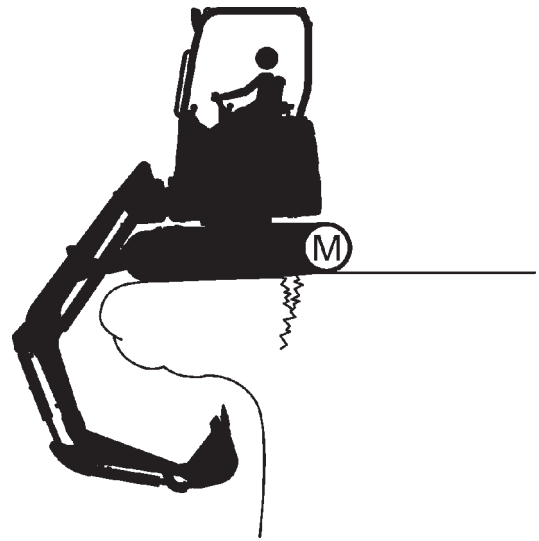

SA-1300 ja

### Avoid Tipping

**DO NOT ATTEMPT TO JUMP CLEAR OF TIPPING MACHINE  
--- SERIOUS OR FATAL CRUSHING INJURIES WILL RESULT  
MACHINE WILL TIP OVER FASTER THAN YOU CAN JUMP FREE  
FASTEN YOUR SEAT BELT**

- The danger of tipping is always present when operating on a grade, possibly resulting in serious injury or death. To avoid tipping:
- Be extra careful before operating on a gradient.
  - Prepare machine operating area flat.
  - Keep the bucket low to the ground and close to the machine.
  - Reduce operating speeds to avoid tipping or slipping.
  - Avoid changing direction when traveling on grades.
  - NEVER attempt to travel across a grade steeper than 15 degrees if crossing the grade is unavoidable.
  - Reduce swing speed as necessary when swinging loads.
- Be careful when working on frozen ground.
  - Temperature increases will cause the ground to become soft and make ground travel unstable.

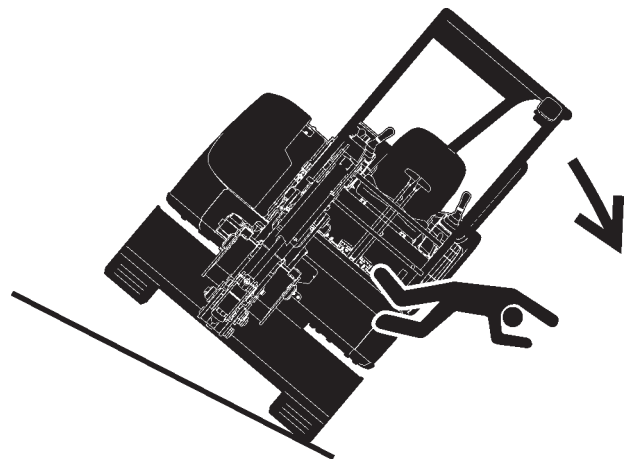

SA-1301 ja

## SAFETY

---

### Never Undercut a High Bank

- The edges could collapse or a land slide could occur causing serious injury or death.

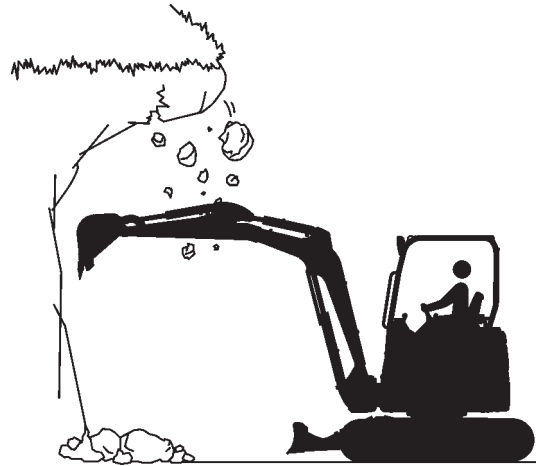

SA-1302 ja

### Dig with Caution

- Accidental severing of underground cables or gas lines may cause an explosion and/or fire, possibly resulting in serious injury or death.
  - Before digging check the location of cables, gas lines, and water lines.
  - Keep the minimum distance required, by law, from cables, gas lines, and water lines.
  - If a fiber optic cable should be accidentally severed, do not look into the end. Doing so may result in serious eye injury.
  - Contact your local "diggers hot line" if available in your area, and/or the utility companies directly. Have them mark all underground utilities.

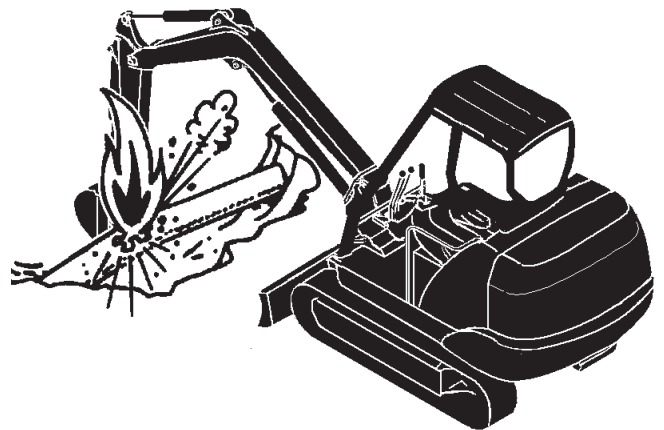

SA-672 ja

### Operate with Caution

- If the front attachment or any other part of the machine hits against an overhead obstacle, such as a bridge, both the machine and the overhead obstacle will be damaged, and personal injury may result as well.
  - Take care to avoid hitting overhead obstacles with the boom or arm.

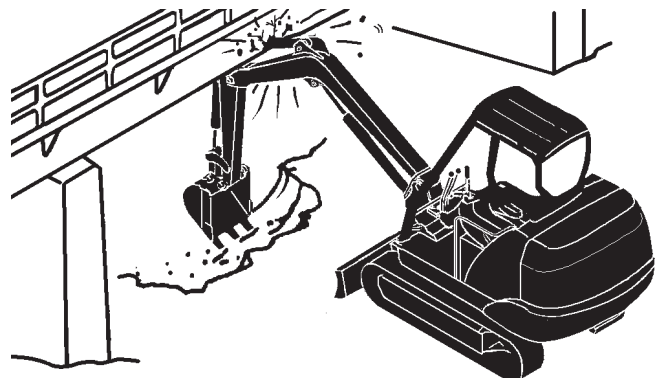

SA-673 ja

## SAFETY

---

### Avoid Power Lines

- Serious injury or death can result if the machine or front attachments are not kept a safe distance from electric lines.
- When operating near an electric line, never move any part of the machine or load to within 3 m plus twice the line insulator length of overhead wires.
- Check and comply with any local regulations that may apply.
- Wet ground will expand the area that could cause any person on it to be affected by electric shock. Keep all bystanders or co-workers away from the site.

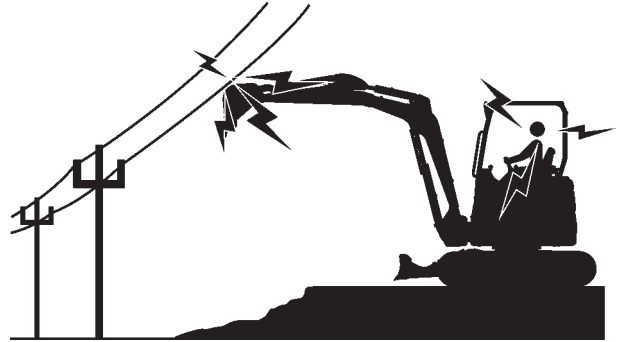

SA-1305 ja

### Precautions for Lightning

- Lightning may strike the machine. If lightning comes close, immediately stop the operation, and take the following action.
  - When you are around the machine or operating cabless machine, evacuate to a safe place far away from the machine.
  - When you are in the cab, stay in the cab until lightning has passed and safety is assured. Close the cab doors and windows. Lower the bucket to the ground, and stop the engine. Put your hands on your lap to avoid contact with any metal surfaces. Never go out of the cab.

If lightning strikes the machine or near the machine, check all of the machine safety devices for any failure after lightning has passed and safety is assured. If any trouble is found, operate the machine only after repairing it.



SA-2744 ja

## SAFETY

---

### Lifting Application

- If a lifted load should fall, any person nearby may be struck by the falling load or may be crushed underneath it, resulting in serious injury or death.
  - When using the machine for craning operations, be sure to comply with all local regulations.
  - Do not use damaged chains or frayed cables, slings, or ropes.
  - Work on level ground. Working on a slope is dangerous as the machine may become unstable.
  - Before craning, position the upperstructure with the travel motors at the rear.
  - Move the load slowly and carefully. Never move it suddenly.
  - When swinging the machine with a load, be careful not to hit anyone nearby with the load and take care not to tip the machine over due to centrifugal force. Reduce engine speed to low and swing at a slow rate.
  - Keep all persons well away from the load.
  - Never move a load over a person's head.
  - Do not allow anyone to approach the load until it is safely and securely situated on supporting blocks or on the ground.
  - Never attach a sling or chain to the bucket teeth. They may come off, causing the load to fall.
  - If traveling with a load is unavoidable, adjust the engine speed to slow and travel slowly.
  - Never move the front end or swing the machine while traveling as making the load sway is dangerous.

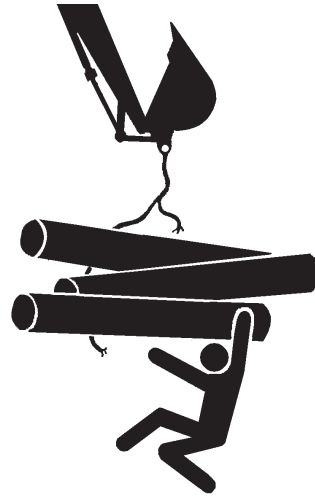

SA-014 ja

## SAFETY

---

### Protect Against Flying Debris and Falling Object

- During hammer operation, debris from earth, rock or metal may fly in all directions, resulting in a serious injury or death.
  - When driving the connecting pins in or out, wear hard hat and face shield, goggle or safety glasses.

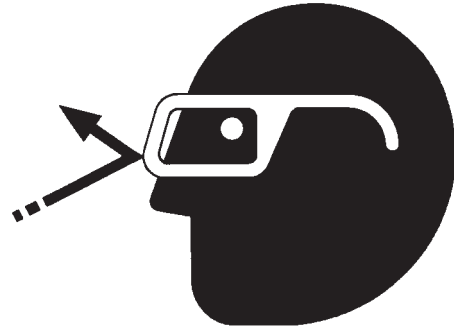

SA-432 ja

- During machine operation, debris from earth, rock or metal may fly off from the track and bucket, potentially resulting in a serious injury or death.
  - Ensure nobody is present in or around the work area while machine is operating.
  - Always close the front windows, doors, door windows and the overhead window when operating the machine.



SA-344 ja

- Falling of accumulated earth or dirt onto people may result in a serious injury or death.
  - Before performing maintenance or inspection under carriage, remove accumulated debris.



SA-527 ja



## SAFETY

---

### Park Machine Safely

- To avoid accidents:
  - Park machine on a firm, level surface.
  - Lower bucket and/or blade to the ground.
  - Pull the pilot control shut-off lever to the LOCK position.
  - Run engine at slow idle speed without load for 5 minutes.
  - Turn key switch to OFF to stop engine.
  - Remove the key from the key switch.
  - Close windows, roof vent, and cab door.
  - Lock all access doors and compartments.



M1M7-05-024 ja

---

### Handle Fluids Safely—Avoid Fires

- Handle fuel with care; it is highly flammable. If fuel ignites, an explosion and/or a fire may occur, possibly resulting in serious injury or death.
  - Do not refuel the machine while smoking or when near open flame or sparks.
  - Always stop the engine before refueling the machine.
  - Fill the fuel tank outdoors.
- All fuels, most lubricants, and some coolants are flammable.
  - Store flammable fluids well away from fire hazards.
  - Do not incinerate or puncture pressurized containers.
  - Do not store oily rags; they can ignite and burn spontaneously.
  - Securely tighten the fuel and oil filler caps.



SA-018 ja



SA-019 ja

# SAFETY

## Transport Safely

- Take care the machine may turn over when loading or unloading the machine onto or off of a truck or trailer.
  - Observe the related regulations and rules for safe transportation.
  - Select an appropriate truck or trailer for the machine to be transported.
  - Be sure to use a signal person.
  - Always follow the following precautions for loading or unloading:
    1. Select solid and level ground.
    2. Always use a ramp or deck strong enough to support the machine weight.
    3. Select the slow travel mode for loading or unloading the machine.

Before descending a slope, always ensure that engine control lever (1) is in the slow idle position, and then reduce the engine speed. Turn the travel mode switch (2) to slow speed for ZX26U-6.

4. Never load or unload the machine onto or off a truck or trailer using the front attachment functions when driving up or down the ramp.
5. Never steer the machine while on the ramp. If the traveling direction must be changed while on the ramp, unload the machine from the ramp, reposition the machine on the ground, then try loading again.
6. At the top end of the ramp where it meets the flatbed, there is a sudden bump. Take care when traveling over it.
7. Place blocks in front of and behind the tires. Securely fasten the machine to the truck or trailer deck with wire ropes. Be sure to further follow the details described in the "TRANSPORTING" section.

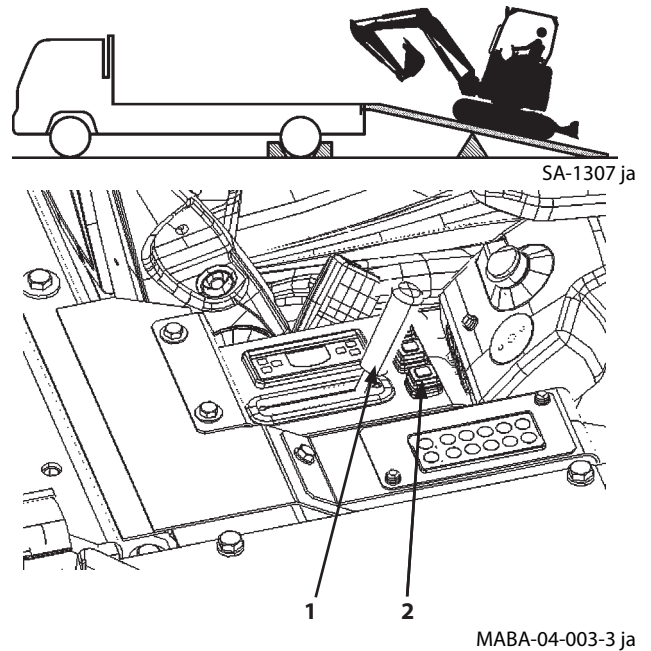

## SAFETY

### Practice Safe Maintenance

- To avoid accidents:
  - Understand service procedures before starting work.
  - Keep the work area clean and dry.
  - Do not spray water or steam inside cab.
  - Never lubricate or service the machine while it is moving.
  - Keep hands, feet and clothing away from power-driven parts.

Before servicing the machine:

1. Park the machine on a level surface.
  2. Lower the bucket to the ground.
  3. Run the engine at slow idle speed without load for 5 minutes.
  4. Turn the key switch to OFF to stop engine.
  5. Relieve the pressure in the hydraulic system by moving the control levers several times.
  6. Remove the key from the key switch.
  7. Attach a "Do Not Operate" tag on the control lever.
  8. Pull the pilot control shut-off lever to the LOCK position.
  9. Allow the engine to cool.
- If a maintenance procedure must be performed with the engine running, do not leave the machine unattended.
  - If the machine must be raised, maintain a 90 to 110° angle between the boom and arm. Securely support any machine elements that must be raised for service work.



SA-028 ja

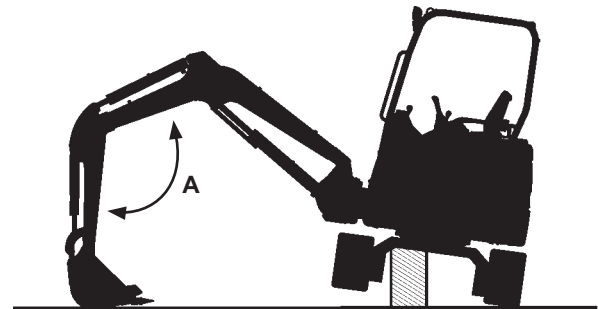

A: 90 to 110°

M1M7-04-006-1 ja

## SAFETY

- Inspect certain parts periodically and repair or replace as necessary. Refer to the section discussing that part in the "MAINTENANCE" chapter of this manual.
- Keep all parts in good condition and properly installed.
- Fix damage immediately. Replace worn or broken parts. Remove any buildup of grease, oil, or debris.
- When cleaning parts, always use nonflammable detergent oil. Never use highly flammable oil such as fuel oil and gasoline to clean parts or surfaces.
- Turn the battery disconnect switch to OFF before adjusting the electrical systems or performing welding on the machine.
- Sufficiently illuminate the work site. Use a maintenance work light when working under or inside the machine.
- Always use a work light protected with a guard. If the light bulb is broken, spilled fuel, oil, antifreeze fluid, or window washer fluid may catch fire.



SA-527 ja



SA-037 ja

### Warn Others of Service Work

- Unexpected machine movement can cause serious injury.
  - Before performing any work on the machine, attach a "Do Not Operate" tag on the control lever. This tag is available from your authorized dealer.
  - Never attempt to operate the machine with a "Do Not Operate" tag attached.
  - Make it a rule for the inspection/service person to hold the engine start key during inspection/service work.



SS2045102-4 ja

## SAFETY

---

### Support Machine Properly

- Never attempt to work on the machine without securing the machine first.
  - Always lower the attachment to the ground before you work on the machine.
  - If you must work on a lifted machine or attachment, securely support the machine or attachment. Do not support the machine on cinder blocks, hollow tires, or props that may crumble under continuous load. Do not work under a machine that is supported solely by a jack.



SA-527 ja

---

### Stay Clear of Moving Parts

- Contact with moving parts can cause serious injury or death due to amputation or entanglement.
  - To prevent accidents, care should be taken to ensure that hands, feet, clothing, jewelry and hair do not become entangled when working around rotating parts.

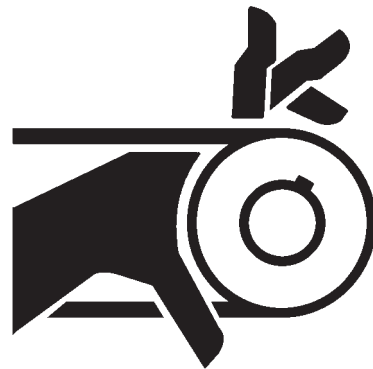

SA-026 ja

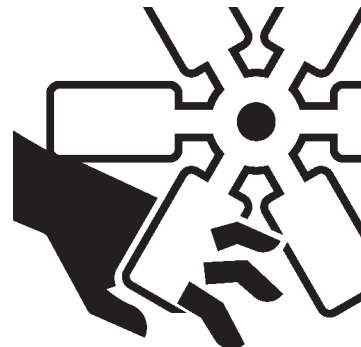

SA-2294 ja

## SAFETY

---

### Prevent Parts from Flying

- Grease in the track adjuster is under high pressure. Failure to follow the precautions below may result in serious injury, blindness, or death.
  - Do not attempt to remove GREASE FITTING or VALVE ASSEMBLY.
  - As pieces may fly off, be sure to keep body and face away from valve.
  - Never attempt to disassemble the track adjuster. Inadvertent disassembling of the track adjuster may cause the parts such as a spring to fly off, possibly resulting in severe personal injury or death.
- Travel reduction gears are under pressure.
  - As pieces may fly off, be sure to keep body and face away from AIR RELEASE PLUG to avoid injury.
  - GEAR OIL is hot. Wait for GEAR OIL to cool, then gradually loosen AIR RELEASE PLUG to release pressure.



SA-344 ja

---

### Avoid Injury from Attachment Falling Accident

- Stored attachments such as buckets, hydraulic hammers, and blades can fall and cause serious injury or death.
  - To avoid possible personal injury from attachment falling accident, use a platform when replacing an attachment.
  - Securely store attachments such as a bucket, blade, breaker and other parts to prevent falling.
  - Keep children and bystanders away from attachment storage areas.

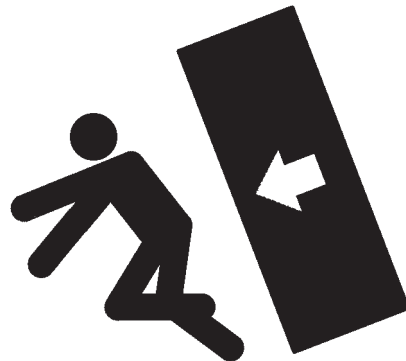

SA-034 ja

## SAFETY

---

### Prevent Burns

#### Hot spraying fluids:

- After operation, engine coolant is hot and under pressure. Hot water or steam is contained in the engine, radiator and heater lines. Skin contact with escaping hot water or steam can cause severe burns.
  - To prevent possible injury from hot spraying water, stop the engine. Begin to work after the engine and radiator are sufficiently cooled.
  - DO NOT remove the radiator cap until the engine is cool. When opening, turn the cap slowly to the stop. Allow all pressure to be released before removing the cap.
  - The hydraulic oil tank is pressurized. Again, be sure to release all pressure before removing the cap.



SA-039 ja

#### Hot fluids and surfaces:

- Engine oil, gear oil and hydraulic oil also become hot during operation. The engine, muffler, hoses, lines and other parts become hot as well.
- Wait for the oil and components to cool before starting any maintenance or inspection work.



SA-225 ja

---

### Replace Rubber Hoses Periodically

- Rubber hoses that contain flammable fluids under pressure may break due to aging, fatigue, and abrasion. It is very difficult to gauge the extent of deterioration due to aging, fatigue, and abrasion of rubber hoses by inspection alone.
  - Periodically replace the rubber hoses. (See the page of "Periodic replacement of parts" in the operator's manual.)
- Failure to periodically replace rubber hoses may cause a fire, fluid injection into skin, or the front attachment to fall on a person nearby, which may result in severe burns, gangrene, or otherwise serious injury or death.



SA-019 ja

## SAFETY

---

### Avoid High-Pressure Fluids

- Fluids such as diesel fuel or hydraulic oil under pressure can penetrate the skin or eyes causing serious injury, blindness or death.
  - Avoid this hazard by relieving pressure before disconnecting hydraulic or other lines.
  - Tighten all connections before applying pressure.
  - Search for leaks with a piece of cardboard; take care to protect hands and body from high-pressure fluids. Wear a face shield or goggles for eye protection.
  - If an accident occurs, see a doctor familiar with this type of injury immediately. Any fluid injected into the skin must be surgically removed within a few hours or gangrene may result.



SA-031 ja

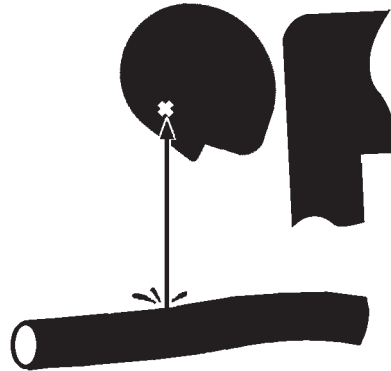

SA-292 ja

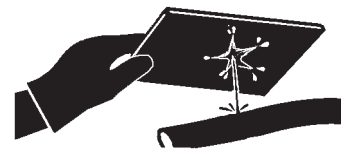

SA-044 ja



# SAFETY

---

## Prevent Fires

### Check for Oil Leaks:

- Fuel, hydraulic oil and lubricant leaks can lead to fires, possibly resulting in personal injury or death.
  - Check for oil leaks due to missing or loose clamps, kinked hoses, lines or hoses that rub against each other, damage to the oil cooler, and loose oil cooler flange bolts.
  - Tighten, repair or replace any missing, loose or damaged clamps, lines, hoses, oil cooler and oil cooler flange bolts.
  - Do not bend or strike high-pressure lines.
  - Never install bent or damaged lines, pipes, or hoses.
  - Replace fuel hoses and hydraulic hoses periodically even if there is no abnormality in their external appearance.



SA-019 ja

### Check for Shorts:

- Short circuits can cause fires.
  - Clean and tighten all electrical connections.
  - Check before each shift or after eight (8) to ten (10) hours operation for loose, kinked, hardened or frayed electrical cables and wires.
  - Check before each shift or after eight (8) to ten (10) hours operation for missing or damaged terminal caps.
  - DO NOT OPERATE MACHINE if cable or wires are loose, kinked, etc.
  - Never attempt to modify electric wirings.

## **SAFETY**

---

### **Clean up Flammable Materials:**

- Spilled fuel and oil, trash, grease, debris, accumulated coal dust, and other flammable materials may cause fires.
  - Prevent fires by inspecting and cleaning the machine daily, and by removing adhered oil or accumulated flammable materials immediately. Check and clean high temperature parts such as the exhaust outlet and muffler earlier than the normal interval.
  - Do not wrap high temperature parts such as a muffler or exhaust pipe with oil absorbents.
  - Do not store oily cloths as they are vulnerable to catching fire.
  - Keep flammable materials away from open flames.
  - Do not ignite or crush a pressurized or sealed container.
  - Wire screens may be provided on openings on the engine compartment covers to prevent flammable materials such as dead leaves from entering. However, flammable materials which have passed through the wire screen may cause fires. Check and clean the machine every day and immediately remove accumulated flammable materials.

### **Check Key Switch:**

- If a fire breaks out, failure to stop the engine will escalate the fire, hampering fire fighting.
  - Always check key switch function before operating the machine every day:
    1. Start the engine and run it at slow idle.
    2. Turn the key switch to the OFF position to confirm that the engine stops.
  - If any abnormalities are found, be sure to repair them before operating the machine.

### **Check Heat Shield Covers around Engine Compartment**

- If the engine compartment heat shield cover becomes broken or lost, fire may break out.
  - If the engine compartment heat shield cover becomes broken or lost, repair or replace it before operating the machine.

## SAFETY

---

### Evacuating in Case of Fire

- If a fire breaks out, evacuate the machine in the following way:
  - Stop the engine by turning the key switch to the OFF position if there is time.
  - Use a fire extinguisher if there is time.
  - Exit the machine.
  - In an emergency, if the cab door or front or rear window can not be opened, break the front or rear window panes with the emergency evacuation hammer to escape from the cab. Refer to the explanation pages on the Emergency Exit.



SA-393 ja



SS-1510 ja

### Beware of Exhaust Fumes

- Prevent asphyxiation. Engine exhaust fumes can cause sickness or death.
  - If you must operate in a building, be sure there is adequate ventilation. Either use an exhaust pipe extension to remove the exhaust fumes or open doors and windows to bring enough outside air into the area.

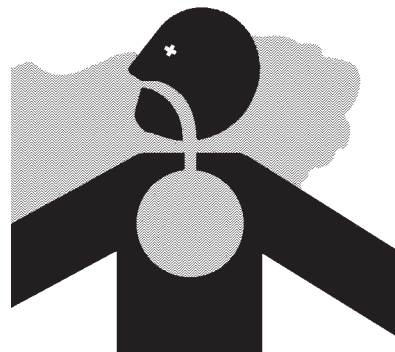

SA-016 ja

## SAFETY

---

### Precautions for Welding and Grinding

- Welding may generate gas and/or small fires.
  - Be sure to perform welding in a well ventilated and prepared area. Store flammable materials in a safe place before starting welding.
  - Only qualified personnel should perform welding. Never allow an unqualified person to perform welding.
  - Turn the battery disconnect switch to the OFF position before performing welding on the machine.
- Grinding on the machine may create fire hazards. Store flammable materials in a safe place before starting grinding.
- After finishing welding and grinding, recheck that there are no abnormalities such as the area surrounding the welded area still smoldering.



SA-818 ja

### Avoid Heating Near Pressurized Fluid Lines

- Flammable spray can be generated by heating near pressurized fluid lines, resulting in severe burns to yourself and bystanders.
  - Do not heat by welding, soldering, or using a torch near pressurized fluid lines or other flammable materials.
  - Pressurized lines can be accidentally cut when heat goes beyond the immediate flame area. Install temporary fire-resistant guards to protect hoses or other materials before engaging in welding, soldering, etc.



SA-030 ja

### Avoid Applying Heat to Lines Containing Flammable Fluids

- Do not weld or flame cut pipes or tubes that contain flammable fluids.
- Clean pipes and tubes thoroughly with non-flammable solvent before welding or flame cutting.

## SAFETY

---

### Precautions for Handling Accumulator and Gas Damper

High-pressure nitrogen gas is sealed in the accumulator and the gas damper. Inappropriate handling may cause explosion, possibly resulting in serious injury or death.

Strictly comply with the following items:

- Do not disassemble the unit.
- Keep the units away from open flames and fire.
- Do not bore a hole, do not cut by torch.
- Avoid giving shocks by hitting or rolling the unit.
- Before disposing of the unit, sealed gas must be released. Consult your authorized dealer.

---

### Remove Paint Before Welding or Heating

- Hazardous fumes can be generated when paint is heated by welding, soldering, or using a torch. If inhaled, these fumes may cause sickness.
  - Remove paint before welding or heating.
  - Avoid potentially toxic fumes and dust.
  - Do all such work outside or in a well-ventilated area. Dispose of paint and solvent properly.
  - Allow fumes to disperse at least 15 minutes after welding or heating.
  - Use attention to the following points when removing paint.
    1. If you sand or grind paint, avoid breathing the dust.  
Wear an approved respirator.
    2. If you use solvent or paint stripper, remove stripper with soap and water before welding. Remove solvent or paint stripper containers and other flammable materials from area.



SA-029 ja

## SAFETY

---

### Beware of Asbestos and Silicon Dust and Other Contamination

- Take care not to inhale dust produced in the work site. Inhalation of asbestos fibers may be the cause of lung cancer. Inhalation of silicon dust or other contaminations may cause sickness.
  - Depending on the work site conditions, the risk of inhaling asbestos fiber, silicon dust or other contaminations may exist. Spray water to prevent asbestos fibers, silicon dust or other contaminations from becoming airborne. Do not use compressed air.
  - When operating the machine in a work site where asbestos fibers, silicon dust or other contaminations might be present, be sure to operate the machine upwind, and wear a mask rated to prevent the inhalation of asbestos, silicon dust or other contaminations.
  - Keep bystanders out of the work site during operation.
  - Asbestos fibers might be present in imitation parts. Use only genuine Hitachi Parts.



SA-029 ja

---

### Prevent Battery Explosions

- Battery gas can explode.
  - Keep sparks, lighted matches, and flame away from the top of battery.
  - Never check battery charge by placing a metal object across the posts. Use a voltmeter or hydrometer.
  - Do not charge a frozen battery; it may explode. Warm the battery to 16 °C ( 60 °F ) first.
  - Do not continue to use or charge the battery when electrolyte level is lower than specified. Explosion of the battery may result.
  - Loose terminals may produce sparks. Securely tighten all terminals.
  - Connect terminals to the correct electrical poles. Failure to do so may cause damage to the electrical parts or fire.
- Battery electrolyte is poisonous. If the battery should explode battery electrolyte may be splashed into eyes, possibly resulting in blindness. If electrolyte is splashed into eyes, flush your eyes continuously with water for about 15 minutes. Seek medical attention immediately.
  - Be sure to wear eye protection when checking electrolyte specific gravity.



SA-032 ja

## SAFETY

---

### Handle Chemical Products Safely

- Direct exposure to hazardous chemicals can cause serious injury. Potentially hazardous chemicals used with your machine include such items as lubricants, electrolyte coolants, paints, and adhesives.
- Safety Data Sheet (SDS) provides specific details on chemical products: physical and health hazards, safety procedures, and emergency response techniques.
- Check the SDS before you start any job using a hazardous chemical. That way you will know exactly what the risks are and how to do the job safely. Then follow procedures and use recommended equipment.
- See your authorized dealer for SDS's (available only in English) on chemical products used with your machine.



SA-2579 ja

---

### Dispose of Waste Properly

- Improperly disposing of waste can threaten the environment and ecology. Potentially harmful waste used with Hitachi equipment includes such items as oil, fuel, coolant, brake fluid, filters, and batteries.
- Use leakproof containers when draining fluids. Do not use food or beverage containers that may mislead someone into drinking from them.
- Do not pour waste onto the ground, down a drain, or into any water source.
- Air conditioning refrigerants escaping into the air can damage the Earth's atmosphere. Government regulations may require a certified air conditioning service center to recover and recycle used air conditioning refrigerants.
- Inquire on the proper way to recycle or dispose of waste from your local environmental or recycling center, or from your authorized dealer.

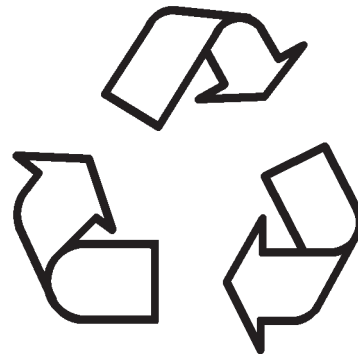

SA-226 ja

---

### Never Ride Attachment

Never allow anyone to ride on attachments or the load. This is an extremely dangerous practice.

---

### Precautions for Communication Terminal

Electrical wave transmitted from the communication terminal may cause malfunction of other electronic devices. Inquire to the device manufacturer for information on electrical wave disturbance when using an electronic device near the communication terminal.

## **SAFETY**

---

### **Visibility Map for Machine Model ZX17U-6, ZX19U-6 series Personal Hazard**

This machine complies with the essential health and safety requirements for visibility set out by Machinery Directive 2006/42/EC. The map shows remaining impediments to visibility (blind spots) observed by a seated operator (wearing the recommended seat restraint) in the cab using direct vision and the standard visual aids supplied with the machine. Additionally, operators are encouraged to adjust the mirrors provided on the machine to show the areas as indicated below.

This map shows an approximation of areas that are still masked. This can be used as a guide when conducting a site risk assessment, utilized for site management and to consider additional visual aids.



# SAFETY

**Conditions: Driver's visibility on 1mRB and VTC are evaluated under ISO 5006.**

Test Height (on 1mRB):	1.0 m to 1.2 m
(1mRB to VTC/on VTC):	Ground Level
Operator eye Height:	1.2 m from the cab floor
Applicable visual aids:	none

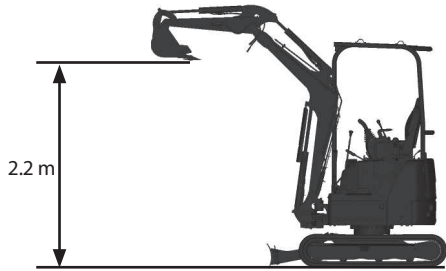

MABK-VM-001-1 en\_GB

⊗ : Operator's eye point  
 A: 1 m Rectangular Boundary (1mRB)  
 B: 12 m Visibility Test Circle (VTC)

C:  : Masking area

Machine Position Image

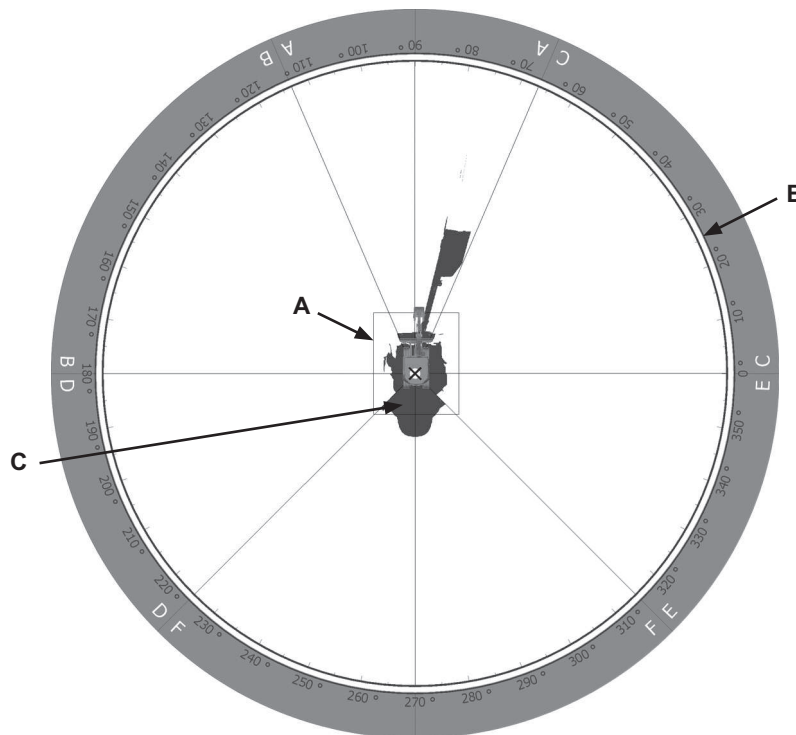

Visibility Map

MABK-VM-002-1 ja

## **SAFETY**

---

---

### **Visibility Map for Machine Model ZX26U-6 series Personal Hazard**

This machine complies with the essential health and safety requirements for visibility set out by Machinery Directive 2006/42/EC. The map shows remaining impediments to visibility (blind spots) observed by a seated operator (wearing the recommended seat restraint) in the cab using direct vision and the standard visual aids supplied with the machine. Additionally, operators are encouraged to adjust the mirrors provided on the machine to show the areas as indicated below.

This map shows an approximation of areas that are still masked. This can be used as a guide when conducting a site risk assessment, utilized for site management and to consider additional visual aids.

# SAFETY

**Conditions: Driver's visibility on 1mRB and VTC are evaluated under ISO 5006.**

Test Height (on 1mRB):	1.0 m to 1.2 m
(1mRB to VTC/on VTC):	Ground Level
Operator eye Height:	1.2 m from the cab floor
Applicable visual aids:	none

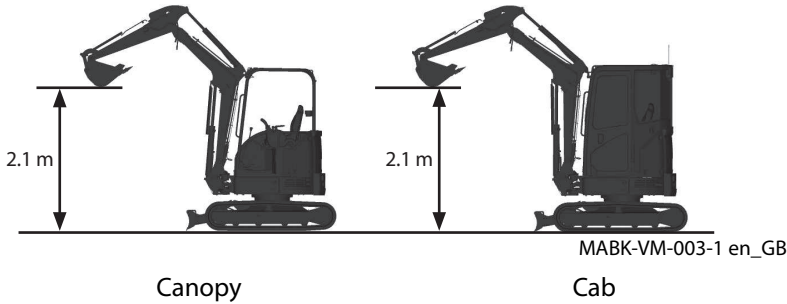

⊗ : Operator's eye point  
 A: 1 m Rectangular Boundary (1mRB)  
 B: 12 m Visibility Test Circle (VTC)

Machine Position Image

C: [shaded area] : Masking area

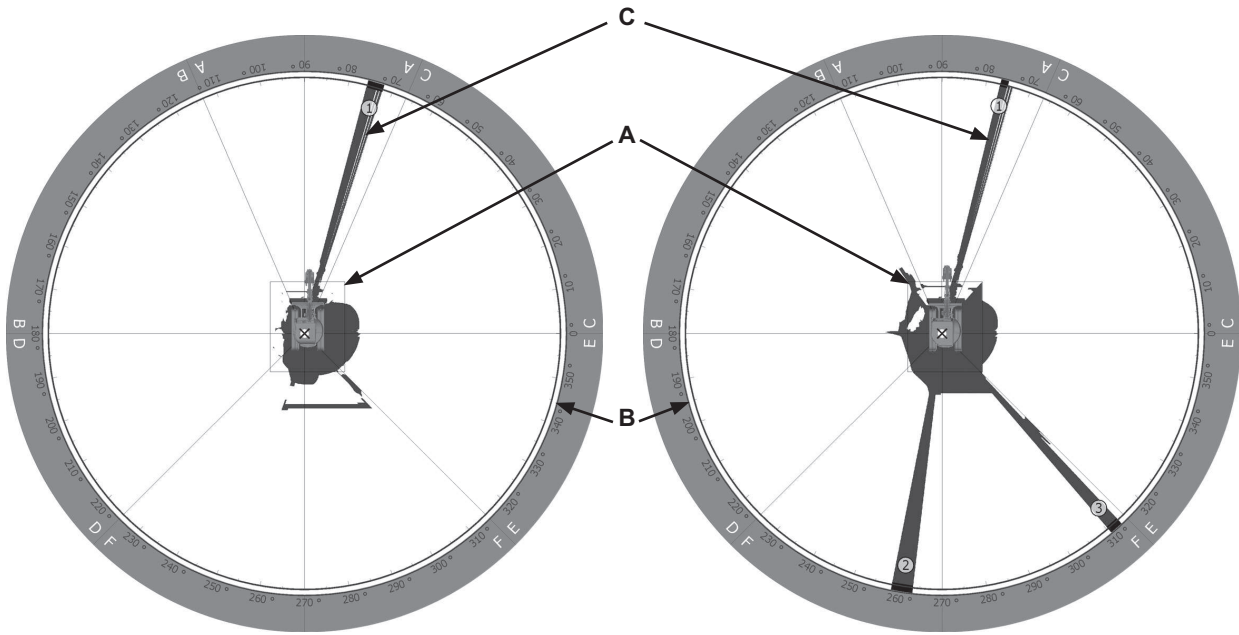

Canopy

Visibility Map

Cab

MABK-VM-006-1 ja

# SAFETY

## Safety Signs

All safety signs and their locations affixed on the machine are illustrated in this group. Make sure of the contents described in the safety signs through reading the actual ones affixed on the machine to ensure safe operation. Always keep the safety signs clean. In case a safety sign is broken or lost, immediately obtain a new replacement and affix it again in the position on the machine. Use the part No. indicated under the right corner of each safety sign illustration when ordering it at your authorized dealer.

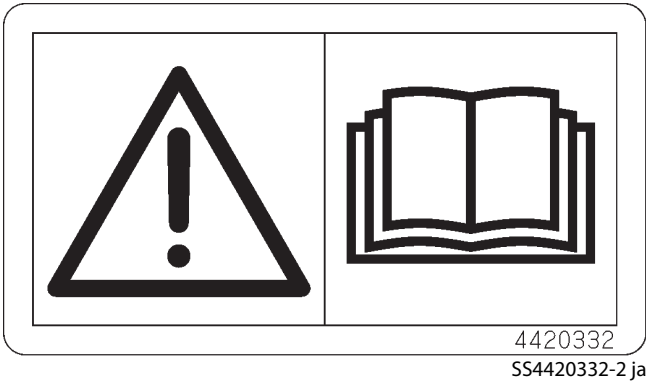

**WARNING!**  
Always read the Operator's manual before operating, servicing, disassembling, assembling, and transporting the machine.

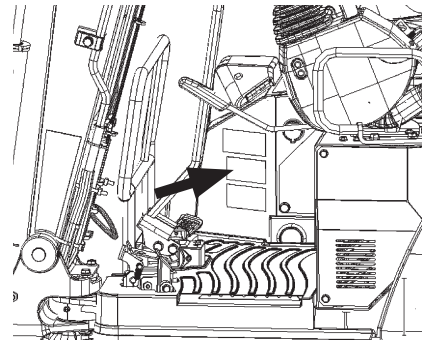

ZX17U-6, 19U-6

MABK-00-001-1 ja

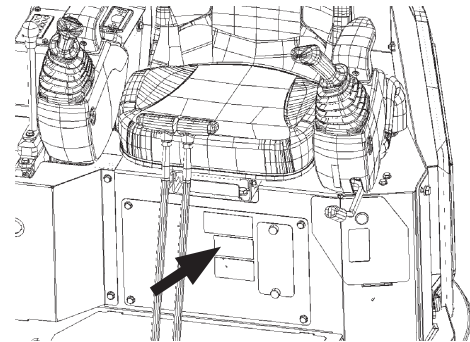

ZX26U-6

MABK-00-002-1 ja

## SAFETY

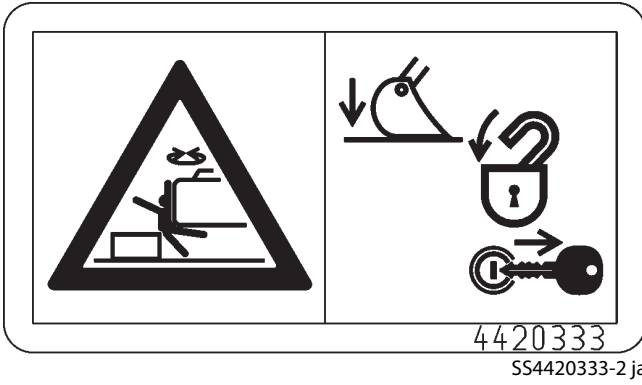

If the machine is parked and moves unexpectedly, serious injury or death due to crushing may result. Be sure to lower the front attachment to the ground, lock the control levers, and remove the engine key before leaving the machine unattended.

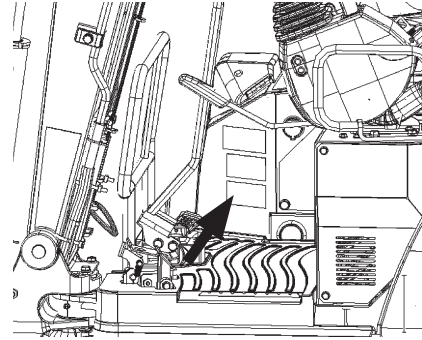

MABK-00-001-2 ja

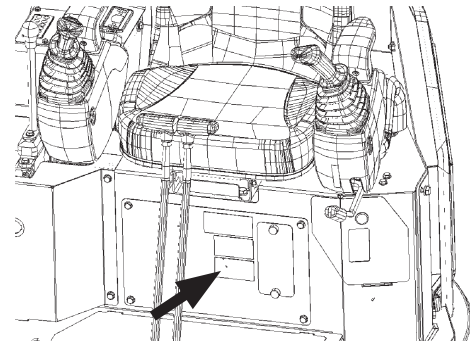

MABK-00-002-2 ja

# SAFETY

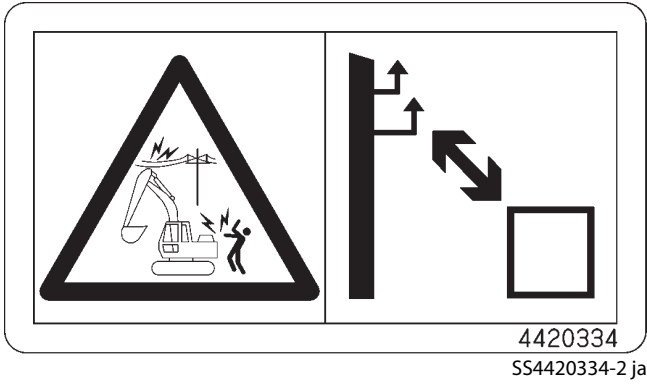

Electrocution is possible if the machine is operated too close to power lines. Always keep a safe distance from power lines.

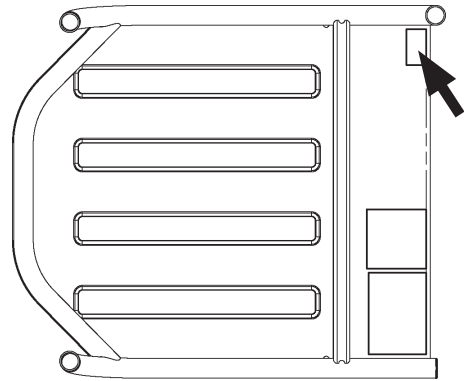

MABK-00-003-1 ja

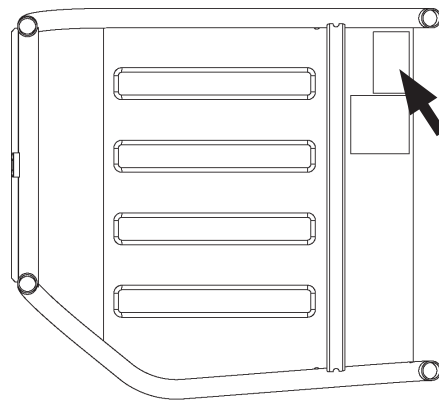

MABK-00-004-1 ja

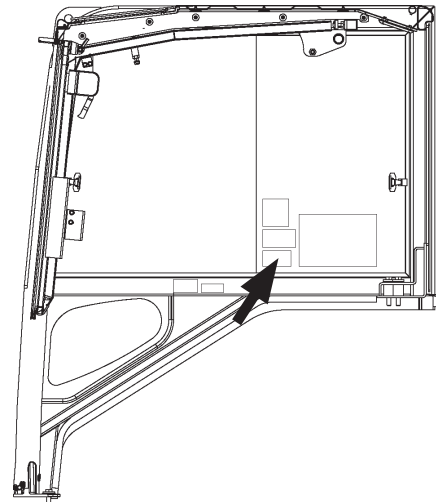

MABK-00-005-1 ja

## SAFETY

---



SS3085503-1 ja

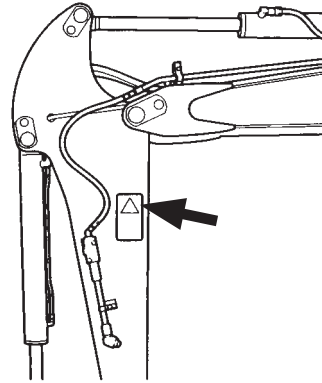

MADB-00-009-4 ja

If hit by equipment a serious injury may result. Stay away from the machine.

## SAFETY



ZX17U-6,19U-6

SS4392290-2 ja

Hot coolant or oil may spout out if the radiator or hydraulic oil cap is removed while the machine is still hot, possibly causing a burn. Wait until the machine has cooled to open the radiator cap.

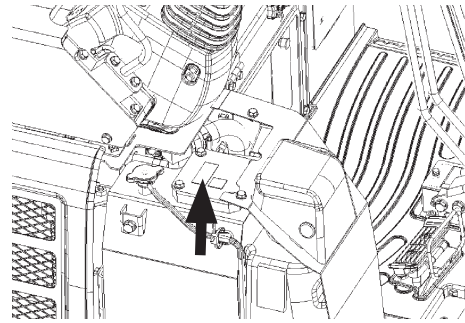

ZX17U-6,19U-6

MABK-00-006-1 ja

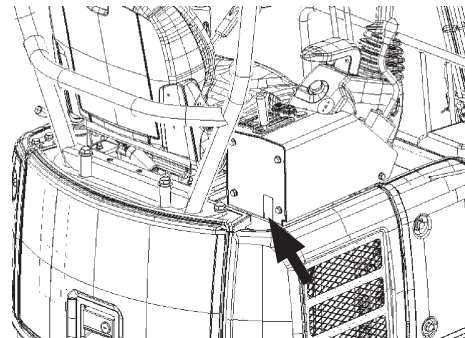

ZX17U-6,19U-6

MABK-00-007-1 ja



## SAFETY



ZX26U-6

SS4420336-3 ja

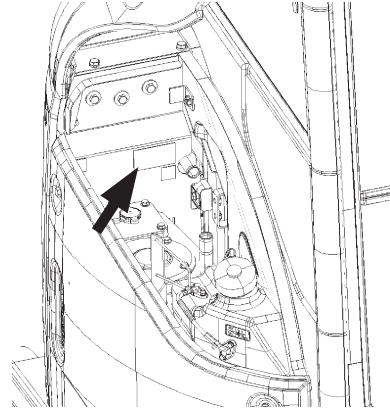

ZX26U-6

MABK-00-008-1 ja

Hot coolant or oil may spout out if the radiator or hydraulic oil cap is removed while the machine is still hot, possibly causing a burn. Wait until the machine has cooled to open the radiator cap.

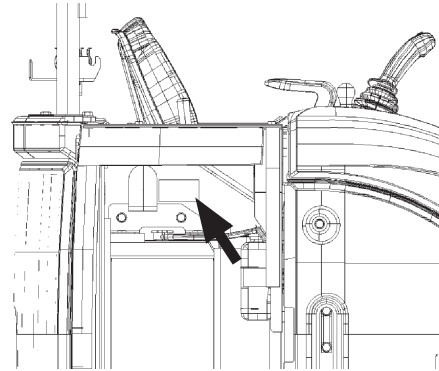

ZX26U-6

MABK-00-009-1 ja

## SAFETY



ZX17U-6, 19U-6

SS4672424-2 ja

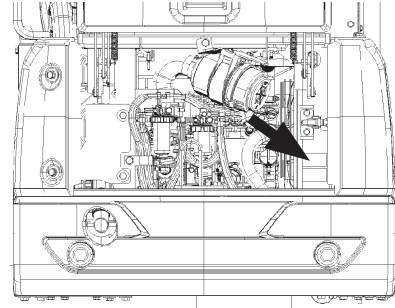

ZX17U-6, 19U-6

MABK-00-010-1 ja

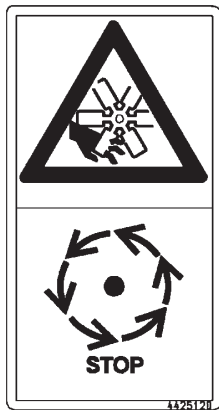

ZX26U-6

SS4425442-1 ja

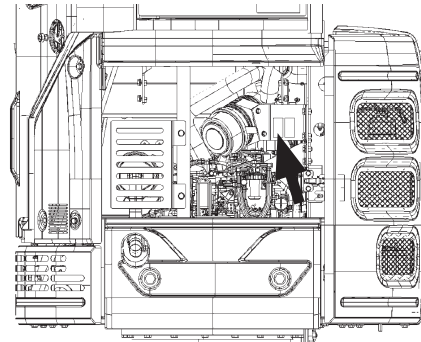

ZX26U-6

MABK-00-011-1 ja

Sign indicates the hazard of rotating parts, such as fan, etc. that could cause injury by being caught.  
Turn it off completely before inspection and maintenance.

## SAFETY

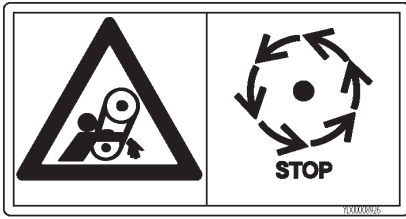

ZX17U-6, 19U-6

SSYD00008926-1 ja

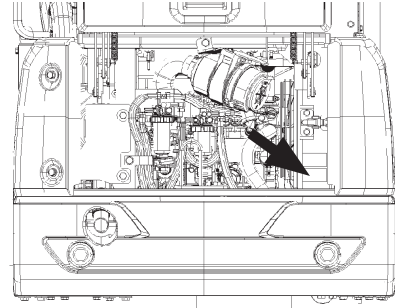

ZX17U-6, 19U-6

MABK-00-010-2 ja

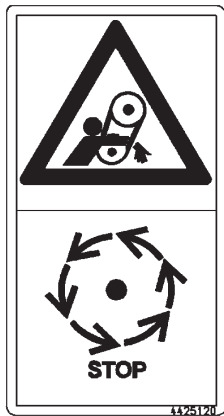

ZX26U-6

SS4425120-1 ja

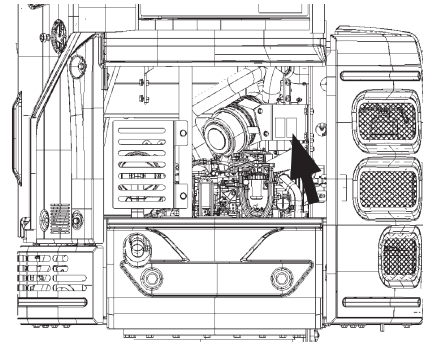

ZX26U-6

MABK-00-011-2 ja

Sign indicates the hazard of rotating parts, such as belt, etc.that could cause injury by being caught.  
Turn it off completely before inspection and maintenance.

## SAFETY



SS4425121-1 ja

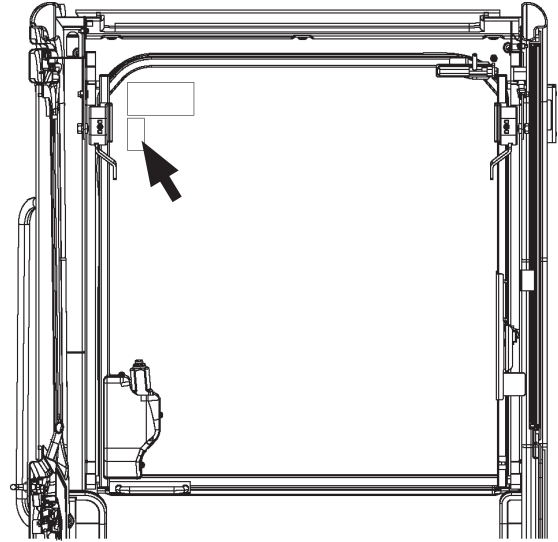

ZX26U-6

MABK-00-012-1 ja

Personal injury may result if the stored front window slips and falls.  
Securely lock the window in its stored position.

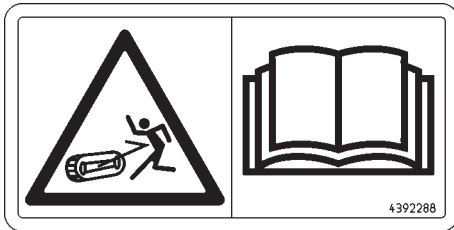

4392288

SS4392288-2 ja

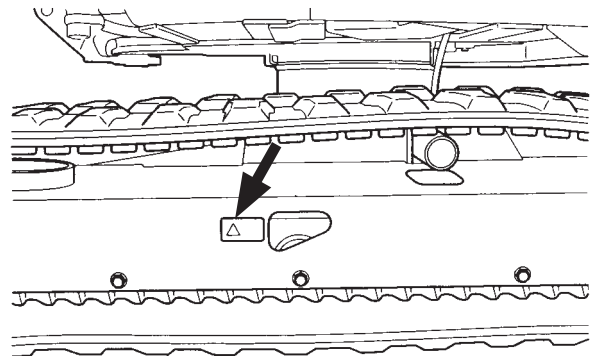

MADB-00-009-9 ja

Serious injury may result if a grease plug or grease flies off the track adjuster.  
Read the Operator's Manual before loosening the track, and adjust the track sag following the correct procedure.

# SAFETY

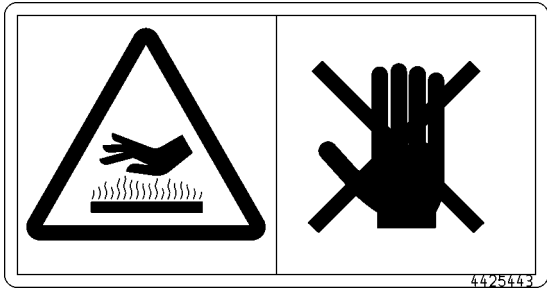

4425443  
SS4425443-2 ja

Touching hot parts (engine, pump, muffler, etc.) during use or immediately after stopping presents the hazard of getting burned. Do not touch hot parts.

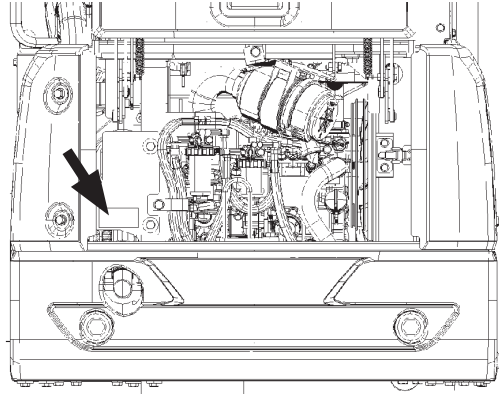

ZX17U-6,19U-6

MABK-00-013-1 ja

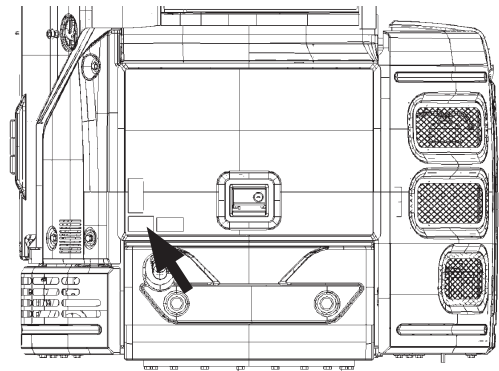

ZX26U-6

MABK-00-014-1 ja

# SAFETY

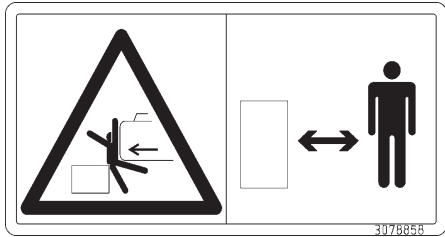

SS3078858-2 ja

Anyone within the swing radius may be crushed by the upperstructure when the machine swings. Stand clear of the swing radius.

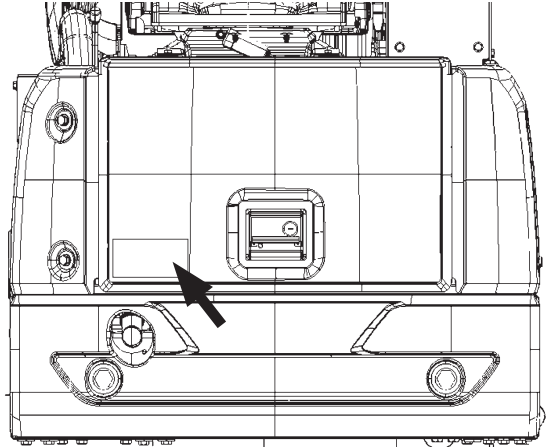

MABK-00-015-1 ja

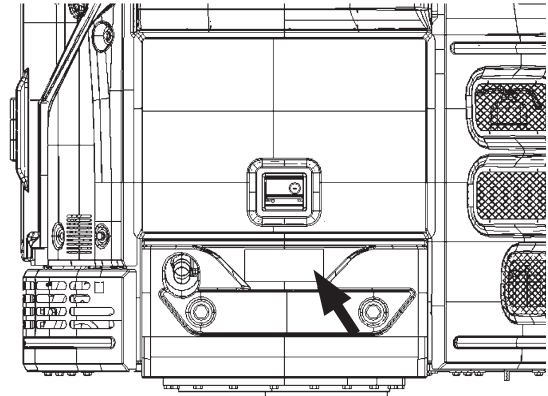

MABK-00-016-1 ja

## SAFETY

---



SS4295807 ja

- Before starting the engine, the pilot control shut-off lever must be in the up position.

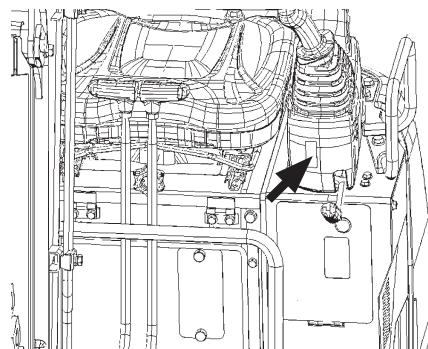

ZX17U-6,19U-6

MABK-00-025-1 ja

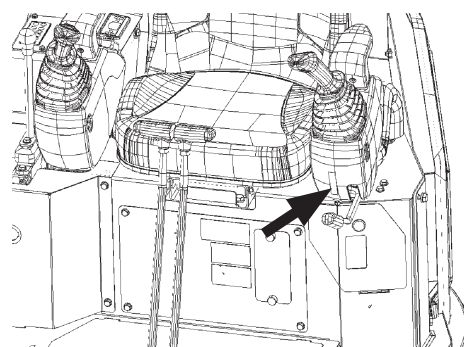

ZX26U-6

MABK-00-002-3 ja

## SAFETY



SS4408870-2 ja

Sign indicates the hazard of rotating parts, such as fan, etc. that could cause injury by being caught.  
Turn it off completely before inspection and maintenance.

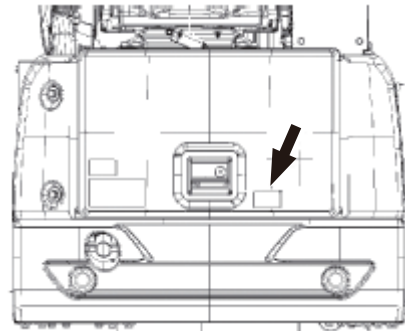

ZX17U-6, 19U-6

MABK-00-017-1 ja

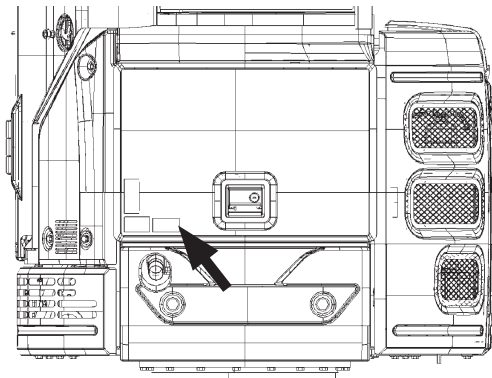

ZX26U-6

MABK-00-014-2 ja



# SAFETY



SS4448289-1 ja

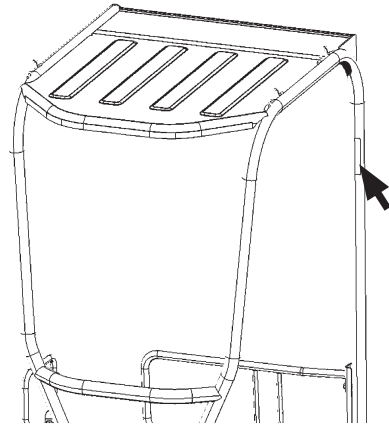

ZX17U-6, 19U-6

MABK-00-018-1 ja

Always sit in the operator's seat and fasten the seat belt when operating the machine. If the machine should overturn, the operator may become injured and/or thrown from the cab and/or crushed by the overturning machine. It may cause serious injury or death.

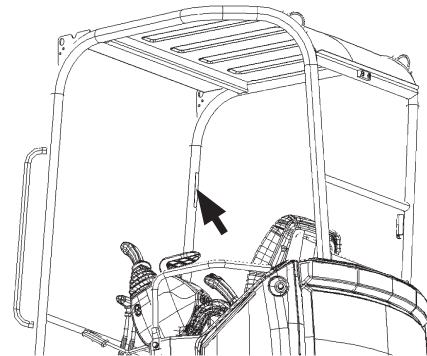

Canopy  
ZX26U-6

MABK-00-019-1 ja

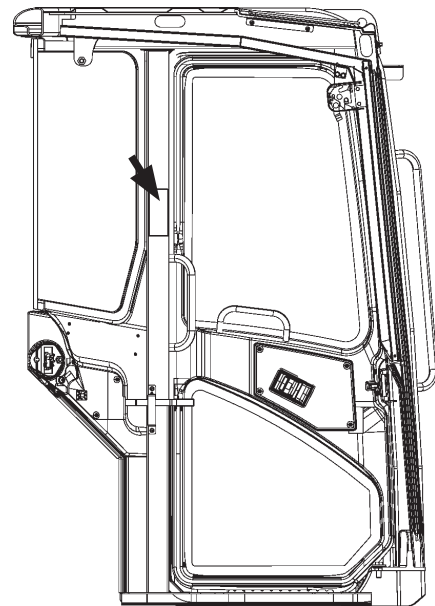

Cab  
ZX26U-6

MABK-00-020-1 ja

## SAFETY

---

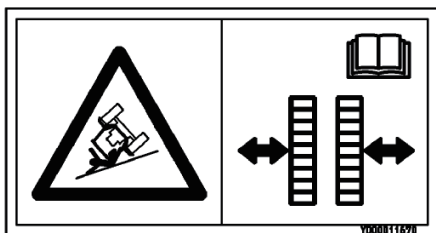

SSYD00011670 ja

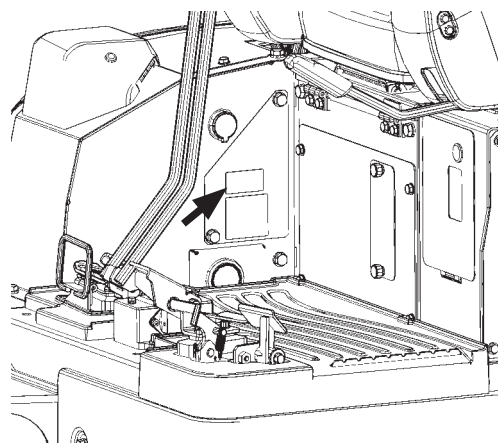

ZX17U-6,19U-6

MABK-00-021-1 ja

Precautions for extending/retracting the side frame

- Operate the machine with the side frames retracted only when traveling on a flat narrow work site.
- Except for the above operating conditions, always operate the machine with the side frames extended for travel, excavation, and blade operations. Failure to do so may cause the machine to turn over.

# SAFETY



SS-4136 ja

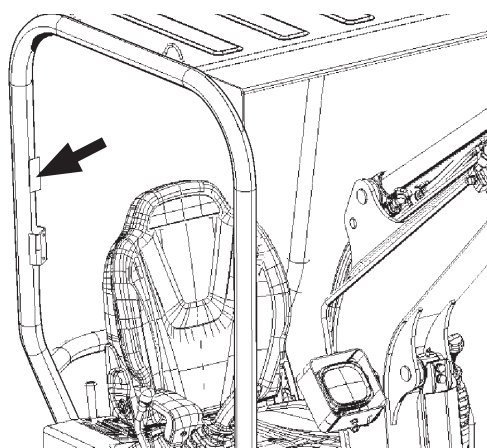

ZX17U-6,19U-6

MABK-00-022-1 ja

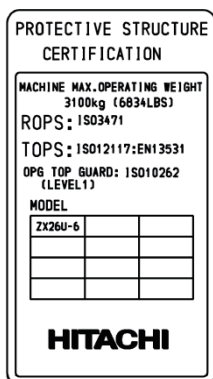

SS-4137 ja

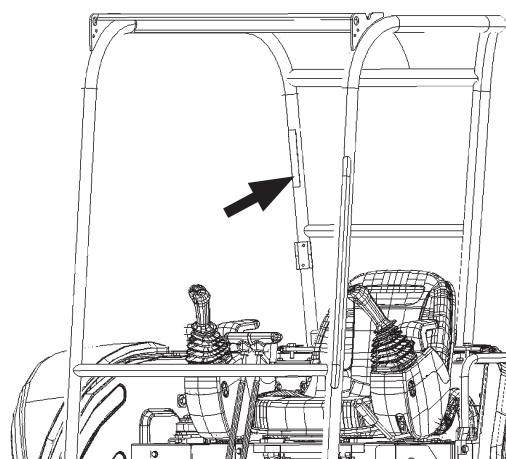
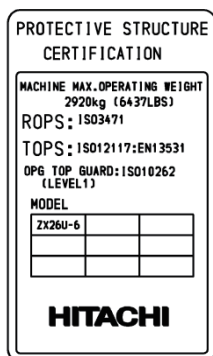

Canopy  
ZX26U-6

MABK-00-023-1 ja

A machine with the above certification posted meets strength authentication for the operator's station (such as ROPS/TOPS/TOP Guard).

Only authorized personnel should ever attempt to modify the ROPS, TOPS or TOP Guard. If an operator's station is detached or a bolt is installed/removed by unauthorized personnel, it may not comply with ROPS, TOPS or TOP Guard.

Consult your nearest authorized dealer when any modification is required.

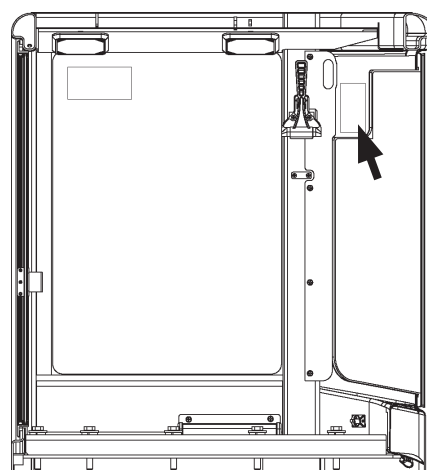

Cab  
ZX26U-6

MABK-00-024-1 ja

## SAFETY

---

---

MEMO

## NAME OF COMPONENTS

### Name of Components

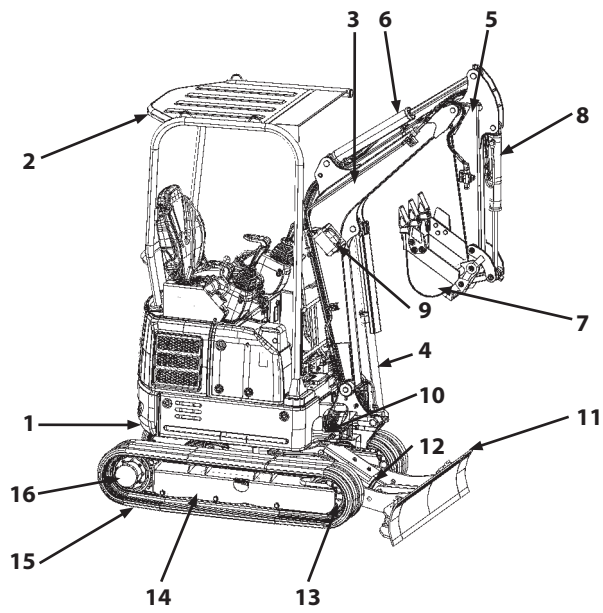

1- Counterweight  
2- Canopy  
3- Boom  
4- Boom Cylinder

5- Arm  
6- Arm Cylinder  
7- Bucket  
8- Bucket Cylinder

9- Work Light  
10- Boom Swing Cylinder  
11- Blade  
12- Blade Cylinder

13- Front Idler  
14- Track Frame  
15- Track  
16- Travel Device

MABA-01-001-1 ja

**NAME OF COMPONENTS**

---

---

**MEMO**

## GETTING ON AND OFF THE MACHINE

### Getting ON and OFF the Machine

Footholds (1) and handrails (4) are provided around the machine for safe entry and exit to the cab. They also allow for safe inspection and maintenance.

Never jump on or off the machine, as doing so is dangerous. Take extra care to avoid contact with door striker (2).

#### WARNING

- When lifting the cab/main body or transporting the machine via truck or trailer, never attach wires to handrails (4) or door striker (2).
- Knob (6), handle (5) on the front window and release lever (7) are not designed as handrails. Do not use them as a handrail when getting on and off the machine.
- Do not hold control levers (3) or pilot control shut-off lever (8) when getting on and off the machine.

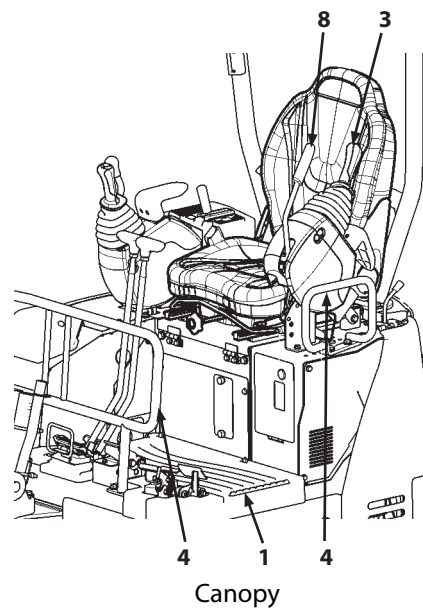

MABA-01-002-1 ja

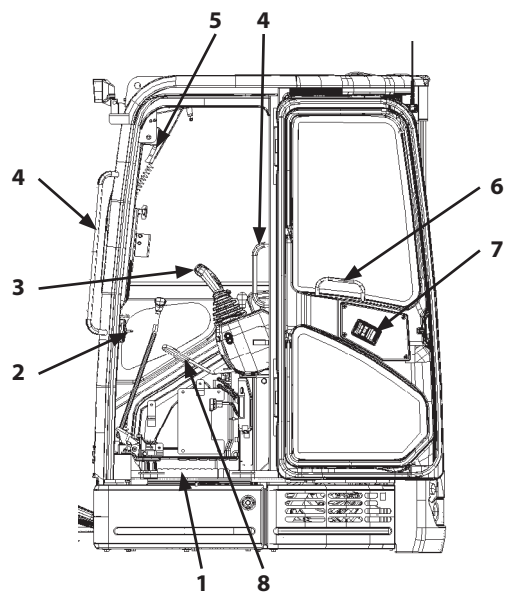

MABA-01-009-1 ja

**GETTING ON AND OFF THE MACHINE**

---

---

**MEMO**



# OPERATOR'S STATION

## Name of Components

### ZX17U-6, 19U-6

- 1- Left Control Lever
- 2- Left Travel Lever
- 3- Right Travel Lever
- 4- Swing Pedal
- 5- Right Control Lever/Horn Switch
- 6- Wrist Rest
- 7- Key Switch
- 8- Monitor
- 9- Seat Back Box (Optional)
- 10- Seat Belt
- 11- Operator's Seat
- 12- Travel Mode Pedal
- 13- Auxiliary Pedal
- 14- Auxiliary Power (Optional)
- 15- Side Frame Extend/Retract Lever
- 16- Pilot Control Shut-Off Lever
- 17- Fuse Box
- 18- Selector Valve
- 19- Blade Lever
- 20- Engine Control Lever
- 21- Numeric Keypad Lock System (Optional)

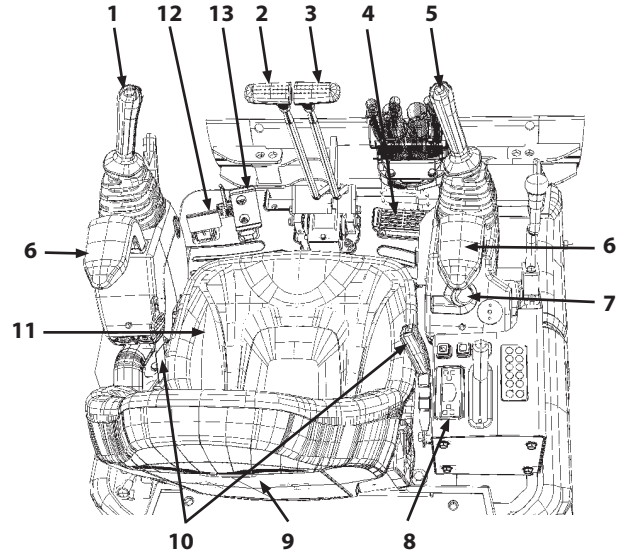

MABA-01-003-1 ja

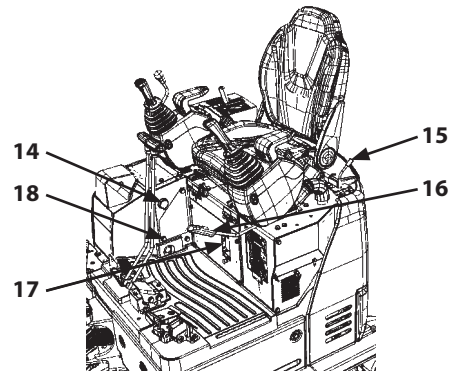

MABA-01-004-1 ja

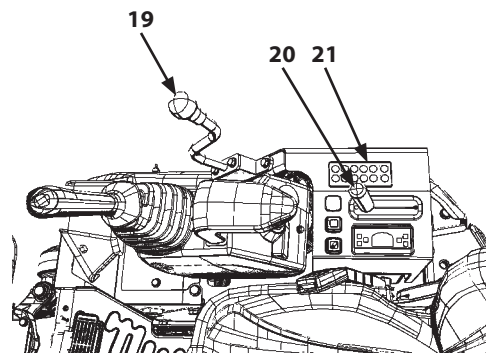

MABA-01-005-1 ja

# OPERATOR'S STATION

## Name of Components

### ZX26U-6

- 1- Left Control Lever
- 2- Left Travel Lever
- 3- Right Travel Lever
- 4- Swing Pedal
- 5- Right Control Lever/Horn Switch
- 6- Wrist Rest
- 7- Key Switch
- 8- Monitor
- 9- Seat Back Box (Optional)
- 10- Seat Belt
- 11- Operator's Seat
- 12- FM/AM Radio (Cab equipped machine) (Optional)
- 13- Door Lock Release Lever (Cab equipped machine)
- 14- Door Opener (Cab equipped machine)
- 15- Auxiliary Pedal
- 16- Auxiliary Power (Optional)
- 17- Pilot Control Shut-Off Lever
- 18- Fuse Box
- 19- Selector Valve

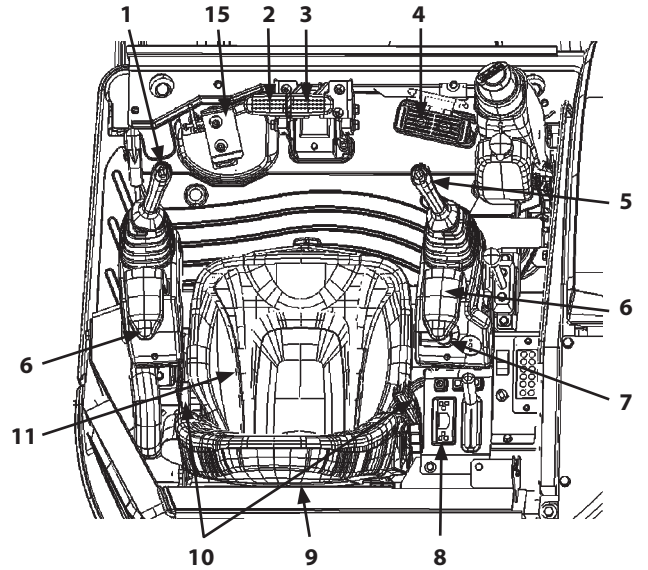

MABA-01-017-1 ja

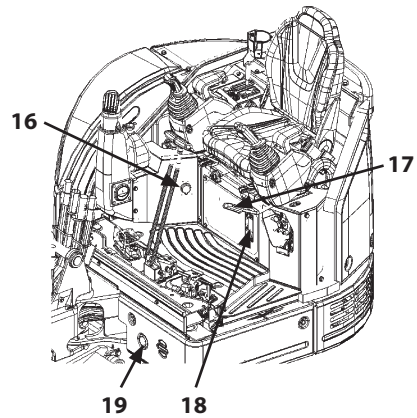

MABA-01-018-1 ja

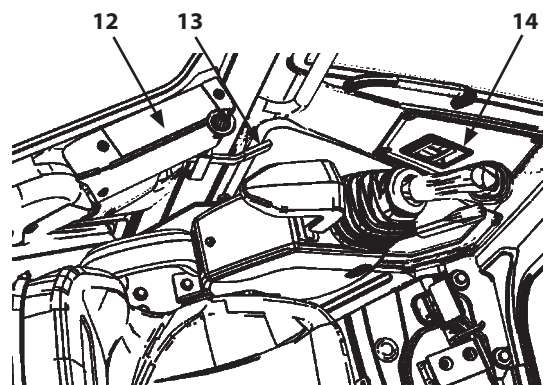

Cab

MABA-01-021-1 ja

## OPERATOR'S STATION

---

- 20- Blade Lever
- 21- Numeric Keypad Lock System (Optional)
- 22- Engine Control Lever
- 23- Heater Switch (Cab equipped machine)
- 24- Travel Mode Switch

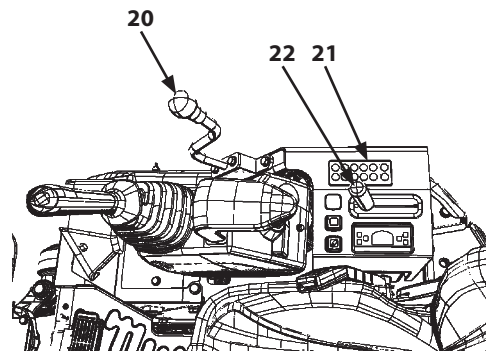

Canopy

MABA-01-005-2 ja

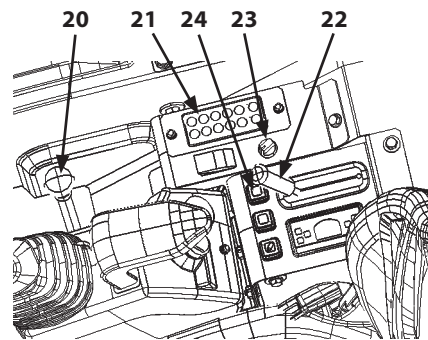

Cab

MABA-01-019-1 ja

# OPERATOR'S STATION

## Key Switch

- 1- OFF (Engine Off )
- 2- ON (Engine ON)
- 3- START (Engine Start)
- 4- HEAT (Preheat)

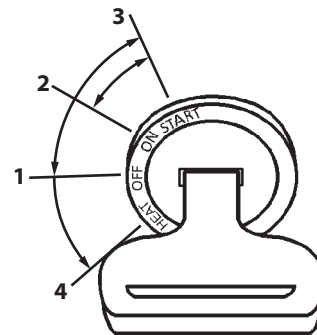

M1M7-01-007-2 ja

## Switch Panel

- 5- Work Light Switch  
Work light (9) mounted on the boom lights up when switch (5) is pressed.
- 6- Travel Mode Switch (ZX26U-6)
- 7- Heater Control Switch (ZX26U-6) (Cab equipped machine)
- 8- Wiper Switch (ZX26U-6) (Cab equipped machine)  
This is a 3-position switch.  
OFF : The wiper operates.  
Middle : The wiper operates.  
WASHER : The wiper continues to operate and the washer operates.

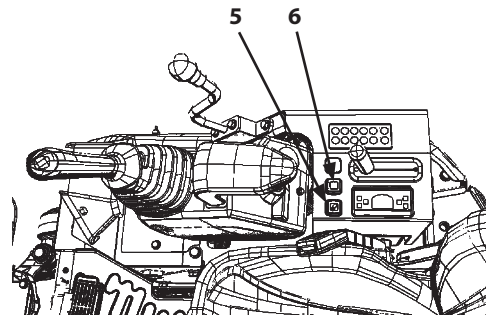

Canopy

MABA-01-005-3 ja

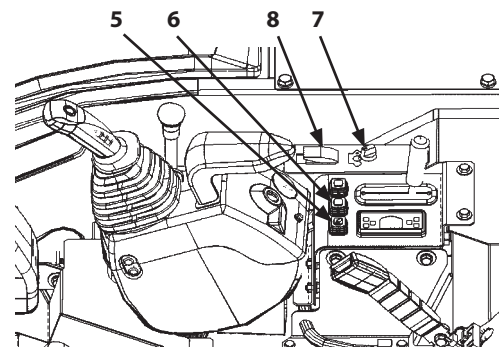

Cab

MABA-01-010-1 ja

## OPERATOR'S STATION

---

### Monitor Panel

- 1- Alternator Indicator
- 2- Fuel Level Indicator
- 3- Preheat Indicator
- 4- Overheat Indicator
- 5- Engine Oil Pressure Indicator
- 6- Hour Meter
- 7- Fuel Gauge
- 8- Coolant Temperature Indicator

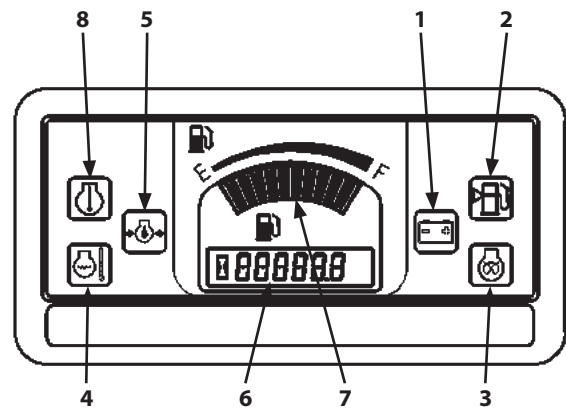

M1NC-01-005-1 ja

## OPERATOR'S STATION

---

### Alternator Indicator

This lamp indicates a problem in the electrical system while the engine is running. If the voltage from the alternator is below the designated range, the red light comes ON. Check the alternator and the battery systems.

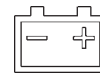

M178-01-038 ja

### Fuel Level Indicator

When the remaining fuel indicator comes ON while on flat ground, the remaining fuel level is as follows. Refill as soon as possible.



M178-01-034 ja

Model	Fuel level
ZX17U-6, 19U-6	Approximately 5 L
ZX26U-6	Approximately 6 L

### Preheat Indicator

Lights when the key is turned to the HEAT position. Once in the HEAT position, the preheat indicator turns off when preheating is complete. Preheating takes the following amount of time.



M178-01-041 ja

Model	Time to Preheat
ZX17U-6, 19U-6	4 seconds
ZX26U-6	15 seconds

## OPERATOR'S STATION

---

### Overheat Indicator

This indicator warns of an abnormal increase in the coolant temperature. The red light comes ON and the buzzer sounds simultaneously. When the red light comes ON and the buzzer sounds, immediately stop operating the machine, and run the engine at slow idle speed to lower the coolant temperature.



M178-01-036 ja

### Engine Oil Pressure Indicator

This lamp warns of low engine oil pressure. The red light comes ON and the buzzer sounds simultaneously. If the red light comes ON and the buzzer sounds, immediately stop the engine and check the engine oil system and the oil level.



M178-01-037 ja

### Hour Meter

The hour meter indicates the cumulative number of hours the machine has been operated.

The last digit on the right indicates tenths of an hour (6 minutes).



M1NC-01-006 ja

### Fuel Gauge

The amount of fuel is indicated by the segment display. Refuel before the needle reaches "E".



M1NC-01-007 ja

### Coolant Temperature Indicator

Lights if the engine coolant is cold when the engine switch is turned ON.



M1NC-01-008 ja

# OPERATOR'S STATION

## Using the Heater (ZX26U-6) (Cab equipped machine)

### Cab Heater Operation (ZX26U-6) (Cab Equipped Machine)

#### Heater Operation

Turn heater cock (1) in the engine compartment counterclockwise. Adjust air flow by turning heater adjust knob (2) located at the right- rear in the operator's station.

#### Blower Operation

Turn heater cock (1) in the engine compartment clockwise to close it. Adjust air flow following the same method as mentioned in the Heater Operation.

#### Defroster Operation

Adjust air flow by operating heater adjust knob (2). Remove clouding on the window pane by directing air flow from air vents (3) and (4) toward the window pane.

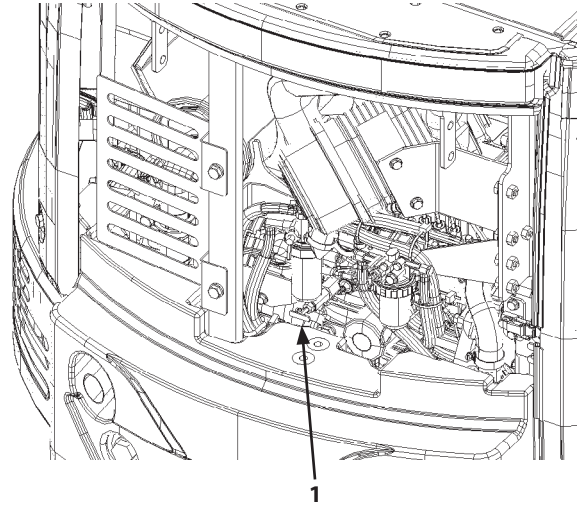

MABA-01-011-1 ja

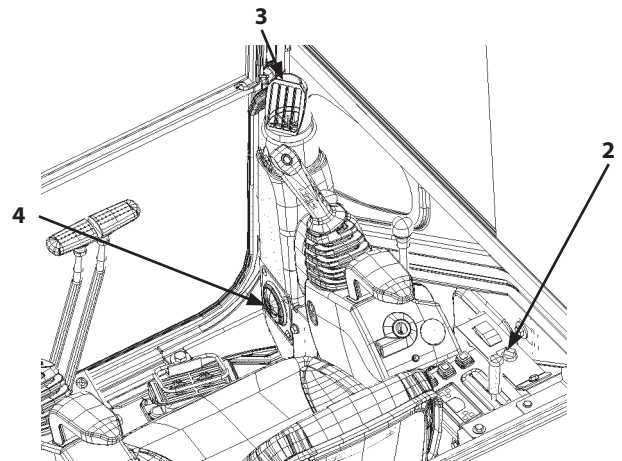

MABA-01-012-1 ja



## OPERATOR'S STATION

---

### Radio (ZX26U-6) (Cab equipped machine) (Optional)

1- Radio/Clock

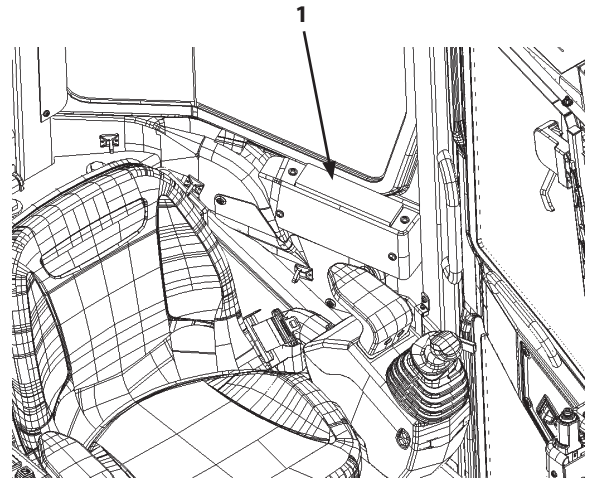

MABA-01-013-1 ja

## OPERATOR'S STATION

### AM/FM Radio Operation (Cab equipped machine)

#### Part Name and Function

- 1- Power Switch  
Push this switch to turn ON/OFF the radio.
- 2- Sound Control Switch (SOUND)  
Push this switch to adjust sound (Balance/Bass/Treble).
- 3- Up/Down Buttons (UP/DOWN)  
This button is used to change the radio wave frequency, adjust the sound parameter and the clock setting.
- 4- Display  
Time, radio receiving frequency and operation mode are displayed.
- 5- AM/FM Switch (AM/FM)  
"FM" and "AM" are switched over alternately each time the switch is pressed. The display indicates the receiving station frequency.
- 6- Display Switch (DISP)  
Push this switch to switch over the display between radio wave frequency and time.
- 7- Preset Switch (PRESET)  
One FM and MW (AM) station per button can be preset using these respective buttons.
- 8- Volume Control Button (VOL)  
Push this switch to adjust the volume.
  - ▶ Push the button to increase the volume in a step-by-step manner.
  - ◀ Push the button to decrease the volume in a step-by-step manner.

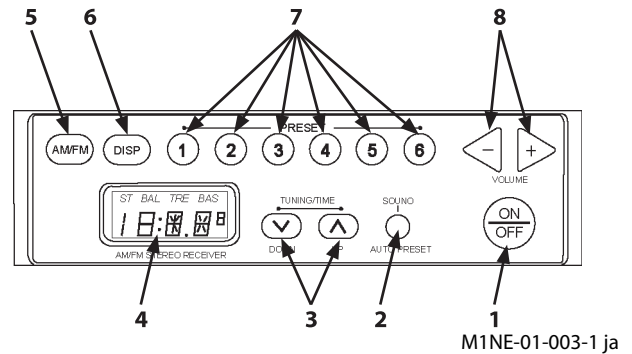

M1NE-01-003-1 ja

#### Radio Operation

1. Turn the engine key switch to ON position. Push radio power switch (1) ON.
2. Select either MW (AM) or FM by operating AM/FM switch (5).
3. Select the station according to your preference using PRESET buttons (7) or UP/DOWN buttons (3).
4. Adjust the volume and tone according to your preference.
5. When turning the radio OFF, repress power switch (1).

# OPERATOR'S STATION

## Tuning Procedure

1. Manual Tuning Procedure  
Push UP button (3) to increase the frequency by one step. Push DOWN button (3) to decrease the frequency by one step.
2. Automatic Tuning (Auto-Seeking)  
Push UP button (3) or DOWN button (3) long to scan the frequency upward or downward. When a station is received, the auto-seeking function is deactivated so that the received frequency station is tuned in.

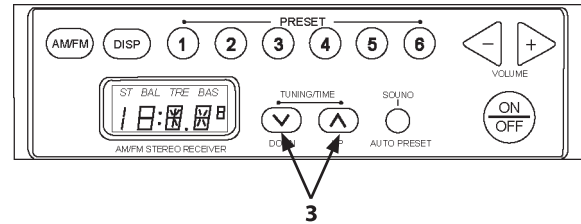

M1NE-01-003-2 ja

## Station Presetting Procedure

1. Select MW (AM) or FM by pushing AM/FM switch (5). Select the station according to your preference using UP/DOWN buttons (3).
2. Push one of PRESET buttons (7) long to save the receiving frequency in memory. When the preset procedure completes, the PRESET button No. flashes 3 times and frequency display becomes ON.
3. Repeat steps 1 and 2 for other PRESET buttons (7).
  - Station Auto-Presetting Procedure  
Pushing SOUND control switch (2) long with the radio switch ON will search for the optimum receiving radio frequency stations and automatically allocate each station in preset memory buttons (1 to 6).

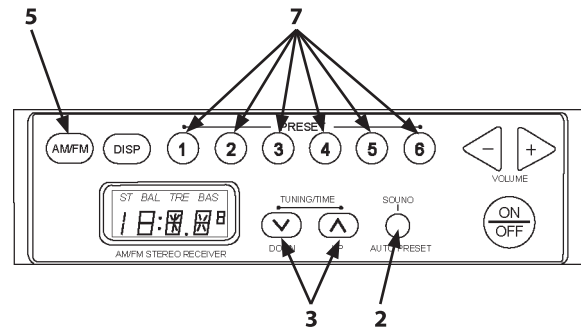

M1NE-01-003-3 ja

### NOTE

Performing auto-presetting operation will delete the stations previously saved in memory.  
If it is difficult to set the memory of the desired station to the desired button, follow the preset procedure.

## Deletion of Preset Memory

If the battery power is disconnected while servicing the machine or by removing the radio, the preset memory in PRESET buttons (7) will be deleted. In this case, preset the stations again.

# OPERATOR'S STATION

## Sound Adjustment

When SOUND control switch (2) is pressed with the radio switch ON, It will be in the sound adjustment state. Each time SOUND control switch (2) is pressed, the adjustment item can be changed as below.

BAL→TRE→BAS→BAL→TRE→BAS When SOUND control switch (2) is pressed with the BAS state, the sound adjustment is deactivated.

- Sound Adjustment (Balance Control)  
When UP button (3) is pressed with the BAL state, loudspeaker output is increased from R output by one step. When DOWN button (3) is pressed with the BAL state, loudspeaker output is decreased from L output by one step.
- Sound Adjustment (Treble Control)  
When UP button (3) is pressed with the TRE state, treble level is increased by one step. When DOWN button (3) is pressed with the TRE state, treble level is decreased by one step.
- Sound Adjustment (Bass Control)  
When UP button (3) is pressed with the Bas state, bass level is increased by one step. When DOWN button (3) is pressed with the Bas state, bass level is decreased by one step.

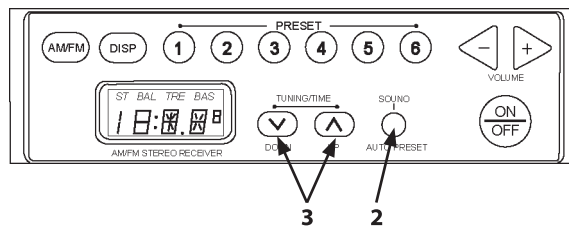

M1NE-01-003-4 ja

## Digital Clock Setting Procedure

Long pressing DISP button (6) in the clock display mode allows the clock to be adjusted.

Pushing DISP button (6) in the clock adjustment mode switches the time unit from hours to minutes. Push UP or DOWN button (3) to adjust the time unit.

Push DISP button (6) in the minute adjustment mode to deactivate the time adjustment.

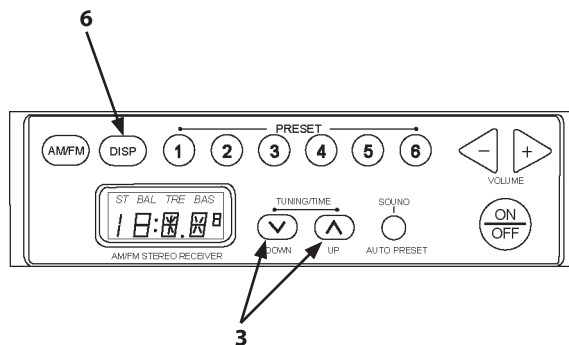

M1NE-01-003-5 ja

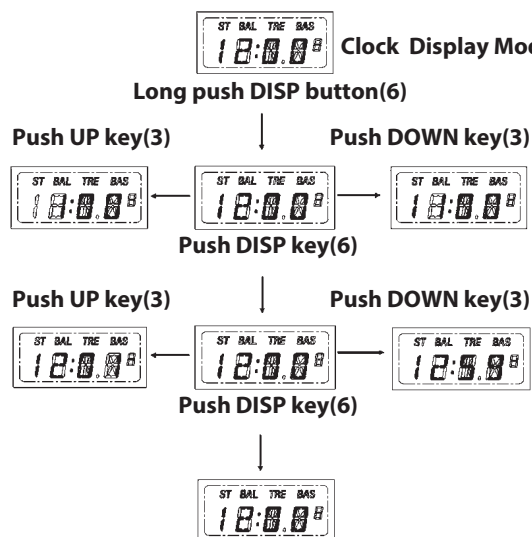

M1NE-01-007-1 en\_GB

## OPERATOR'S STATION

---

### Door Lock Release Lever (ZX26U-6) (Cab equipped machine)

**⚠ CAUTION**

**When opening the door, open it all the way until it securely locks in the latch on the side of the cab.**

To unlock the door, push down on door lock release lever (1) to the left of the operator's seat.

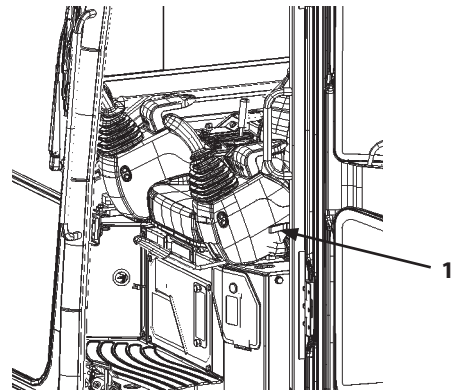

MABA-01-014-1 ja

## OPERATOR'S STATION

### Using the Front Window (ZX26U-6) (Cab equipped machine)

#### Front Window

1. Hold handle (1) at upper part of the front window and pull lock lever (2) with your finger. Release the lock to open the front window.
2. Pull the upper front window up and back along the rail until it securely activates lock lever (2) at the rear end. Then, use handle (3) on the lower front window.
3. After confirming that lock lever (2) is securely activated, slide lock pin (6) to lock the window in position.

#### CAUTION

- **Slowly close the upper front window so as not to catch a finger.**
- **Switch (4) is provided on the front window to prevent the wiper from operating when the front window is opened. Before closing the front window, ensure that the wiper switch is turned OFF.**
- **When opening the front window, ensure that the left and right locks are definitely activated.**

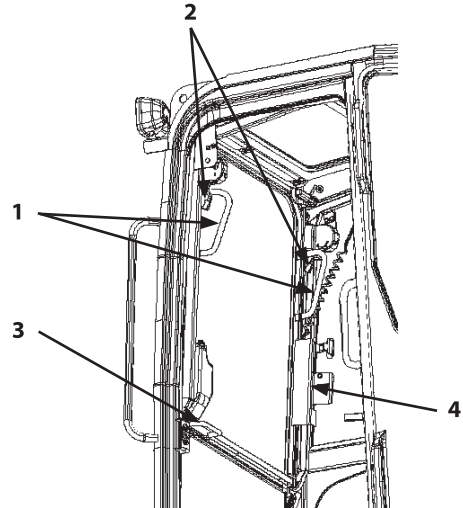

MADB-01-058-1 ja

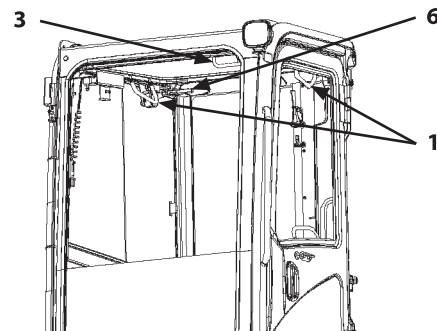

MADB-01-059-1 ja

4. Close the upper front window by following steps 1 and 2 in the reverse order.

#### Removing and Storing Lower Front Window

1. Open the upper front window first when removing the lower front window. Pulling lower front window (5) upward along the window frame releases the window towards the cabin side. Install the lower front window by following the steps in the reverse order.

#### CAUTION

- **Lower window (5) breaks easily if dropped or struck, so carefully place and keep the removed windowpane in a safe storage area.**
- **Take care not to get your fingers caught when handling the lower front window.**

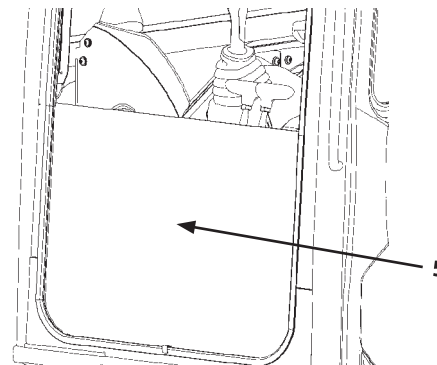

MADB-01-060-1 ja

# OPERATOR'S STATION

## Adjusting the Seat

### Operator's Seat Fore-Aft Adjustment

Operate seat fore-aft slide lever (1) to adjust the seat.  
Adjustable range is as follows.

Model	Adjustable Range
ZX17U-6,19U-6	14 Steps (140 mm in total)
ZX26U-6	11 Steps (110 mm in total)

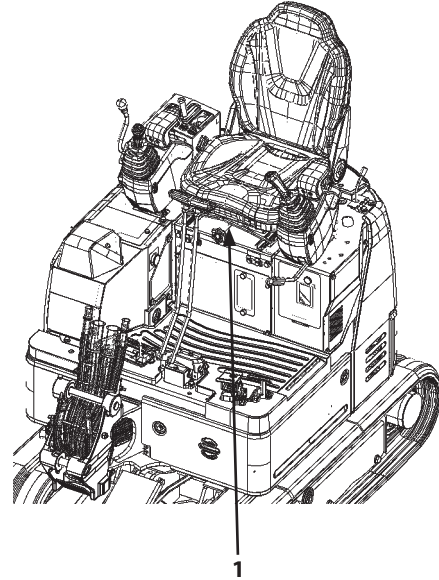

MABA-01-007-1 ja

### Seat Back Box

Pocket (2) is located on the back of the seat. Put the operator's manual inside.

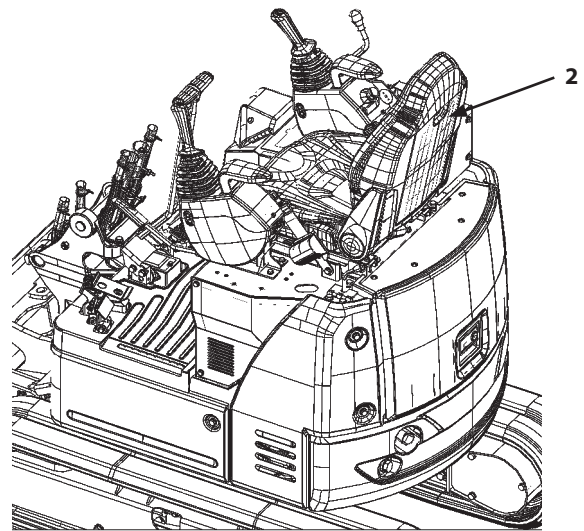

MABA-01-008-1 ja

## OPERATOR'S STATION

### Escaping from the Emergency Exit (ZX26U-6) (Cab equipped machine)

Escape from the cab in an emergency as follows:

#### **CAUTION**

**The danger of falling is always present when escaping from the cab in an emergency, and may result in serious personal injury. Escape from the cab as safely as possible, depending on the position of the machine and the situation outside.**

1. Open the cab door. Escape through the door.
2. If the cab door is difficult to open or use, open the front window. Escape through the window.

#### **NOTE**

*Emergency exit decals (2) are affixed to the front and rear windows. See the section Using the Front Window in Chapter 1 Operator's Cab for how to open the front window.*

#### **CAUTION**

**If decal (2) is affixed to the front windowpane, the windowpane can be broken. However if decal (2) is not affixed to the front windowpane, the glass cannot be broken with emergency evacuation hammer (1). Take care not to be injured by pieces of broken glass.**

3. If the upper front window is difficult to open, check decal (2) affixed to the windowpane. If decal (2) is affixed to the front windowpane, break the front windowpane using the emergency evacuation tool (1) mounted on the left side of the cab. Escape through the broken windowpane.
4. If decal (2) is not affixed to the front windowpane, or if it is not possible to escape through the front window, break the rear windowpane using emergency evacuation hammer (1). Escape through the broken windowpane.

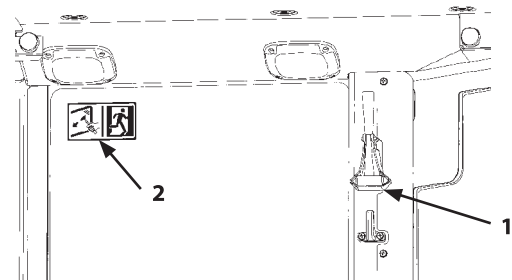

Emergency Evacuation Tool, Rear

MADB-01-063-2 ja

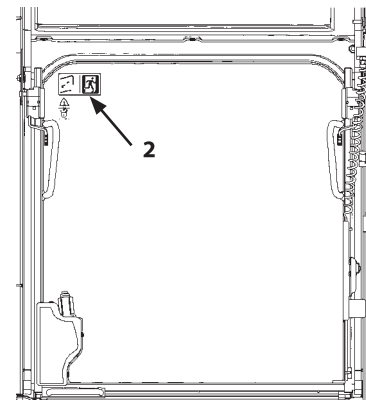

Front

MADB-01-064-2 ja



# OPERATOR'S STATION

---

## Seat Belt

### WARNING

- Be sure to use seat belt (1) when operating the machine.
- Before operating the machine, be sure to examine seat belt (1) and the hardware attached for any failure. Replace the seat belt and the hardware attached if they are damaged and/ or worn.
- Replace seat belt (1) every 3 years, regardless of its appearance.

### Seat Belt

1. Confirm that seat belt (1) is not twisted. Securely insert the end of seat belt into buckle (2). Lightly pull on the belt (1) to confirm that the buckle latches securely.

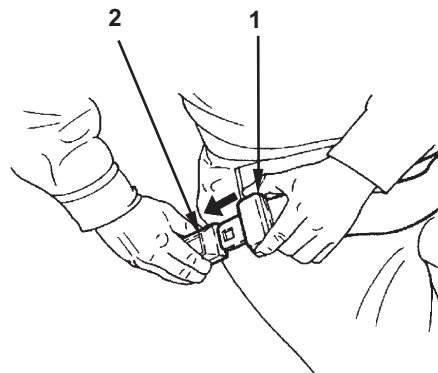

M1NC-01-014-2 ja

2. Adjust seat belt (1) so it fits the operator's body.

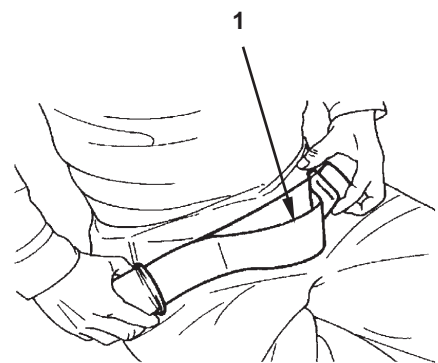

M1NC-01-015-2 ja

3. Push button (3) on buckle (2) to unfasten seat belt (1).

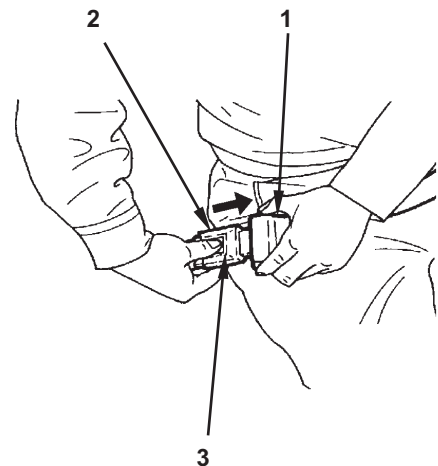

M1NC-01-016-2 ja

## OPERATOR'S STATION

---

### Room Lamp (ZX26U-6) (Cab equipped machine)

Push switch (4) on the cab light to turn the cab light ON.  
(Only lights if the key is ON)

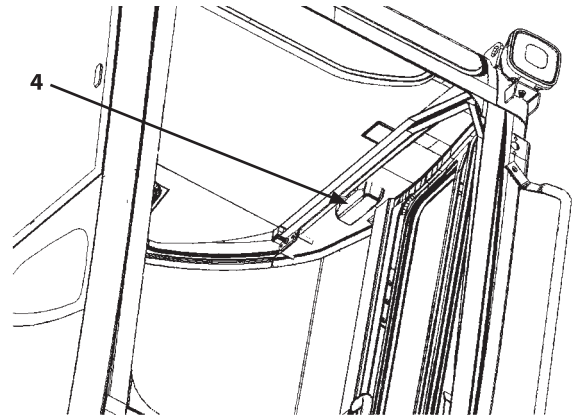

M1M7-01-021-1 ja

## OPERATOR'S STATION

### Battery Disconnect Switch

#### IMPORTANT

- **Do not turn the battery disconnect switch OFF while the engine is running or the key switch is in any position other than OFF. Damage to the electrical system may result.**
- **As it may hit things nearby while the mini-excavator is moving, do not attach any accessories to key (2).**

The battery disconnect switch differs from the engine start key switch. When the battery disconnect switch is turned OFF, the electrical system is cut off, so no electric current flows in the entire circuit.

Before turning the battery disconnect switch OFF, be sure to turn the key switch OFF and let the engine stop. Also, when the battery disconnect switch is turned from OFF to ON, the preset data of the radio or clock may be initialized, so reset them.

Use the battery disconnect switch for the following purposes only.

- For repairs/maintenance on the electrical system
- For long-term storage, to prevent battery discharge
- When welding on the machine
- When replacing the battery

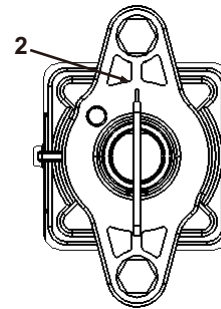

ON

MABK-01-003-2 ja

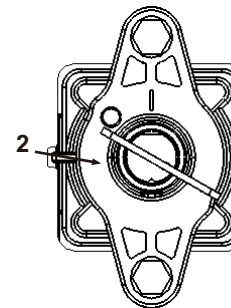

OFF

MABK-01-004-2 ja

# OPERATOR'S STATION

## Switch Operation

1. Open cover (1).  
When key (2) is in the vertical position, the battery disconnect switch is ON.  
Key (2) cannot be removed when vertical as illustrated.  
To operate the machine with the battery disconnect switch is the ON position, close cover (1).
2. When key (2) is turned counterclockwise, the battery disconnect switch turns OFF.  
Key (2) can be removed from the battery disconnect switch when it is in the OFF position.
3. Store key (2) in a safe place after removal to avoid losing it.

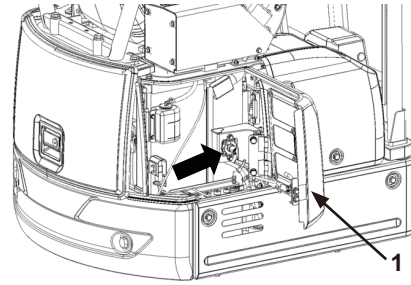

ZX17U-6, 19U-6

MABK-01-001-4 ja

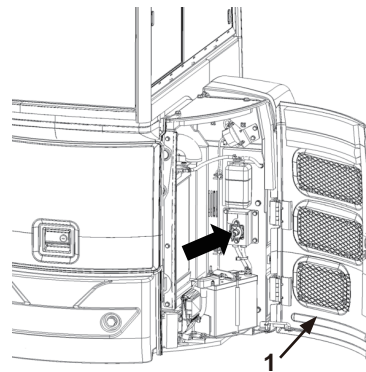

ZX26U-6

MABK-01-002-4 ja

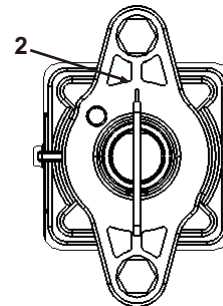

ON

MABK-01-003-2 ja

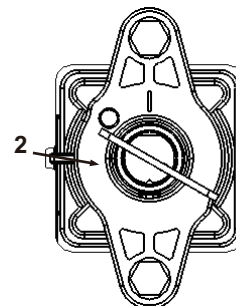

OFF

MABK-01-004-2 ja

## BREAK-IN

---

### Breaking in New Machine

#### **IMPORTANT**

**Operating a new machine at full load without first breaking in can cause scratches and/or seizures, consequently affecting the service life of the machine. Thoroughly perform the break-in operation.**

The service life and the performance of the machine can be greatly affected by operation and maintenance of the machine during the initial stage of operation. Perform the break-in operation with the engine output less than 80% of the maximum output for the first 50 hours.

**BREAK-IN**

---

---

**MEMO**

## OPERATING THE ENGINE

---

### Inspect Machine Daily Before Starting

Perform required daily checks before starting the engine.

#### Engine

- Engine oil and coolant levels, contamination,\*
- Starting ability, exhaust color, abnormal sounds
- Oil or water leaks, damage to hoses or lines
- Clogs or damage to radiator or oil cooler
- Loose or missing mounting bolts or nuts

#### Upperstructure

- Level, leaks, contamination of fuel tank\*
- Level, leaks or contamination of hydraulic oil tank \*
- Operation, play, force required for each control lever
- Operation of each hydraulic device, leaks or damage to lines or hoses
- Deformation, damage or abnormal noises from any part
- Loose or missing mounting bolts or nuts
- Washer fluid\*

#### Undercarriage

- Looseness, wear or damage to tracks\*
- Oil leaks or wear to upper/lower rollers or front idler
- Oil leaks from travel device
- Loose or missing mounting bolts or nuts

#### Work equipment

- Oil leaks or damage to cylinders, lines or hoses
- Wear or damage to bucket
- Loose, worn or missing bucket teeth\*
- Lubrication of parts of front attachment
- Damage to stop pins for retaining pins, stoppers, rings, bolts
- Loose or missing mounting bolts or nuts

#### Other

- Operation of instruments, switches, lights and buzzer/horn\*
- Function of the parking brake
- Deformation or damage to the head guard
- Anything abnormal with the appearance of the machine
- Wear or damage to the seat belt\*

#### NOTE

*\*For details on inspections, refer to Chapter 7 "MAINTENANCE".*

# OPERATING THE ENGINE

## Before Starting the Engine

1. For machines equipped with a battery disconnect switch (5), make sure it is in the ON position.  
Battery disconnect switch (5) is inside the right cover.
2. Confirm that pilot control shut-off lever (1) is in the LOCK position.
3. Confirm that all control levers are placed in neutral.
4. Check for burned out lamps.  
Put key (2) into the key switch and turn to the ON position to turn on indicators and warnings on the monitor panel for about 2 seconds. Any indicators or warnings that fail to light are burned out.  
However, the alternator indicator (3) and engine oil pressure indicator (4) stay lit.

### IMPORTANT

**The monitor panel indicates the control status of the machine. If the machine is used with burned out bulbs, it cannot indicate warnings when something abnormal happens. So, consult your authorized dealer immediately for repairs when a bulb burns out. Similarly, after checking for burned out bulbs, if alternator indicator (3) or engine oil pressure indicator (4) is off, there is a problem with the machine. Consult the nearest Hitachi representative immediately for repairs.**

5. Adjust the operator's seat to allow control pedals and levers to be operated throughout their stroke with the operator's back against the backrest. Fasten the seat belt.

#### NOTE

*The surface of the monitor is made of plastic. When the surface becomes dusty, lightly wipe the surface with a wet cloth. Never use an organic solvent or the like.*

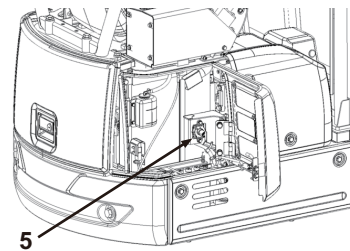

ZX17U-6, 19U-6

MABK-01-001-3 ja

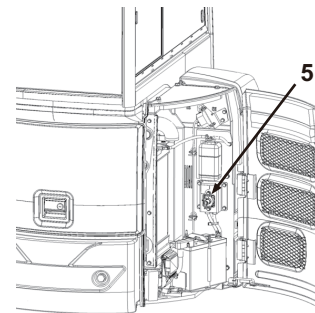

ZX26U-6

MABK-01-002-3 ja

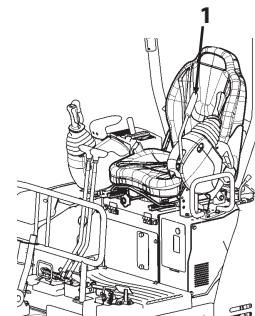

MABA-01-002-4 ja

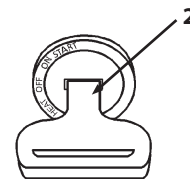

M1M7-01-007-3 ja

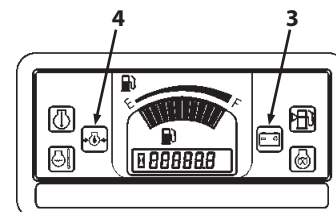

M1NC-01-005-7 ja



# OPERATING THE ENGINE

## Starting the Engine

### Starting the Engine at Ordinary Temperatures

1. Confirm that pilot control shut-off lever (1) is in the LOCK position.
2. Put engine control lever (3) in the slow idle position.
3. Sound horn to alert bystanders.
4. Turn key switch (2) to the START position to turn the starter and start the engine.

### IMPORTANT

**Never operate the starter for more than 15 seconds at a time. If the engine fails to start, return the key switch to the OFF position. Wait for at least 30 seconds, then try again. Failure to follow instructions may cause damage to the starter and/or discharge the batteries.**

5. Release key switch (2) right after the engine starts. Key switch (2) returns automatically to the ON position.

### NOTE

*The horn sounds even when key (2) is in the OFF position. The engine will not start if pilot control shut-off lever (1) is not in the LOCK position.*

### IMPORTANT

**Do not operate key (2) with dirty hands or gloves.**

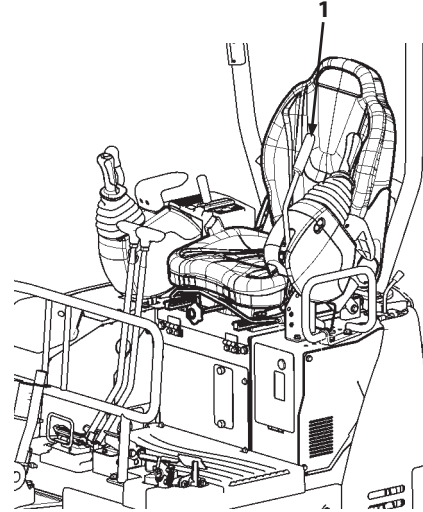

MABA-01-002-2 ja

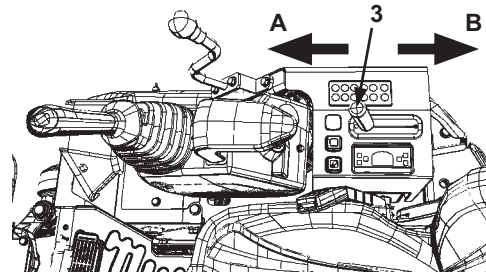

A: Slow Idle B: High Idle

MABA-01-005-4 ja

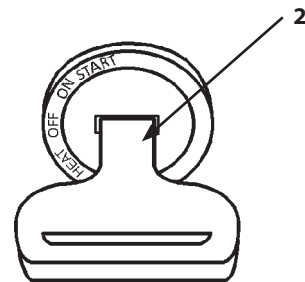

M1M7-01-007-1 ja

# OPERATING THE ENGINE

## Starting in Cold Weather

1. Confirm that pilot control shut-off lever (1) is in the LOCK position.
2. Put engine control lever (3) in the middle.
3. Put key (2) in the HEAT position and hold it there until preheat indicator (4) goes out.
4. Sound the horn to alert bystanders.
5. As soon as preheat indicator (4) goes OFF, turn key switch (2) to the START position to turn the starter.

### IMPORTANT

**Never operate the starter for more than 15 seconds at a time. If the engine fails to start, return the key switch to the OFF position. Wait for at least 30 seconds, then try again.**

**Failure to follow instructions may cause damage to the starter and/or discharge the batteries.**

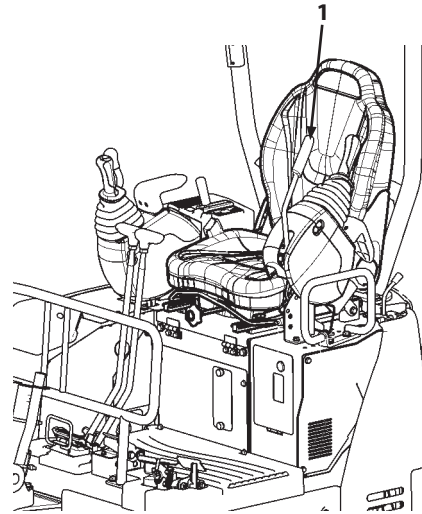

MABA-01-002-2 ja

6. Release key switch (2) just after the engine has started. Key switch (2) returns automatically to the ON position.

### NOTE

*The horn sounds even when key (2) is in the OFF position. The engine will not start if the pilot shut-off lever is not in the LOCK position.*

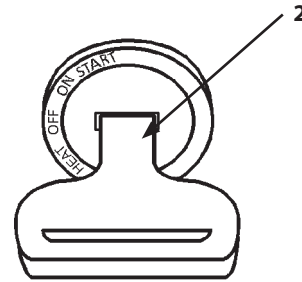

M1M7-01-007-1 ja

### IMPORTANT

**Do not operate key (2) with dirty hands or gloves.**

### NOTE

*When starting in extremely cold conditions, put engine control lever (3) at high idle to start the engine.*

*After starting, gradually lower the engine RPM to a medium speed and warm up the engine.*

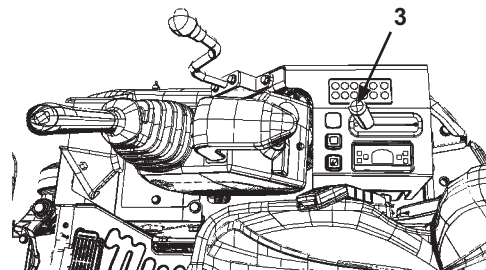

MABA-01-005-5 ja

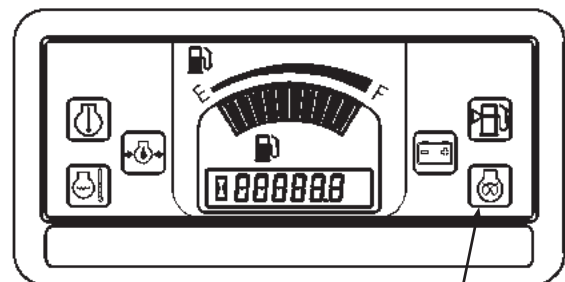

M1NC-01-005-3 ja

## OPERATING THE ENGINE

---

### Check Instruments After Starting Engine

#### IMPORTANT

If anything abnormal is found on the monitor, immediately stop the engine and investigate the cause of the problem.

#### Checking the Monitor

After starting the engine, check the following on the monitor.

1. Check that alternator alarm indicator (1) is OFF.  
If alternator indicator (1) stays ON, immediately stop the engine. Inspect the alternator and battery system for any abnormality.
2. Check that engine oil pressure indicator (2) is OFF.  
If engine oil pressure indicator (2) stays ON, immediately stop the engine. Inspect the engine oil pressure system and the oil level.

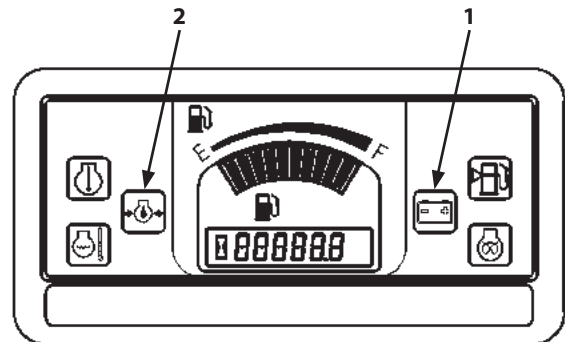

M1NC-01-005-4 ja

#### Check Engine Noise and Exhaust Gas Color

Check that the engine noise and exhaust gas color are normal.

#### NOTE

Visually check exhaust color (after warmup and under no load)

No color or light blue:	Normal (complete combustion)
Black:	Abnormal (incomplete combustion, fuel system problem)
White:	Abnormal (oil in the combustion chamber, fuel system problem)

## OPERATING THE ENGINE

### Using Booster Battery

#### **!** WARNING

- An explosive gas is produced while batteries are in use or being charged. Keep open flames and sparks away from the battery area. Do not continue to use or charge the battery when electrolyte level is lower than specified. Explosion of the battery may result.
- Park the machine and the machine providing the jump on a dry or concrete surface, not on steel plates. If machines are parked on steel plates, it may cause sparking unexpectedly.
- Never connect a positive terminal to a negative terminal. Doing so may cause a short.



SA-032 ja

#### IMPORTANT

The electrical system of the machine is 12 volt DC. Only jump from a machine with a 12 volt DC system that has enough extra capacity.

When the machine's batteries are dead, start the engine by connecting booster cables to the batteries of the jumping vehicle as shown below.

#### Connecting Booster Cables

1. Stop the engine of the machine providing the jump.
2. Connect one end of red cable (1) to the positive (+) terminal of the machine batteries, and the other end to the positive (+) terminal of the booster battery.
3. Connect one end of black cable (2) to the negative (-) terminal of the battery providing the jump, and then ground to hinge (3) of the engine cover of the machine to be started with the other end. Sparks may fly when the last connection is made.
4. After securely connecting the booster cables, start the engine of the machine providing the jump and run at a medium speed.
5. Start the engine of the machine with the dead batteries.
6. After the engine starts, disconnect cables (1) and (2) in the following order.

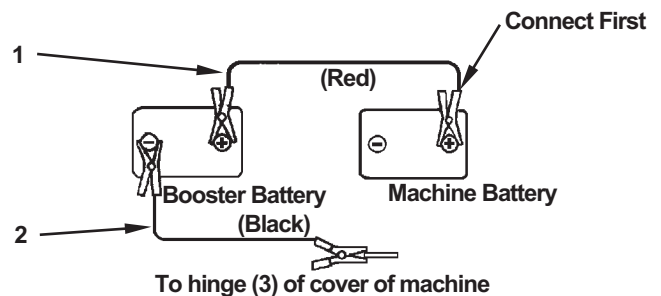

MAAA-03-003-1 en\_GB

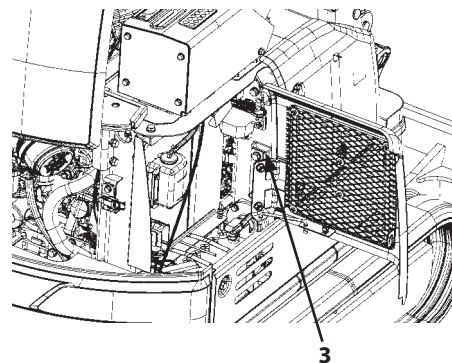

MABA-03-001-1 ja

## OPERATING THE ENGINE

---

### Disconnecting the Booster Cables

1. Disconnect black booster cable (2) where it is connected to hinge (3) of the machine's engine cover.
2. Disconnect the other end of black negative (-) cable (2) from the booster batteries.
3. Disconnect red positive (+) cable (1) from the booster batteries.
4. Disconnect red positive (+) cable (1) from the machine batteries.

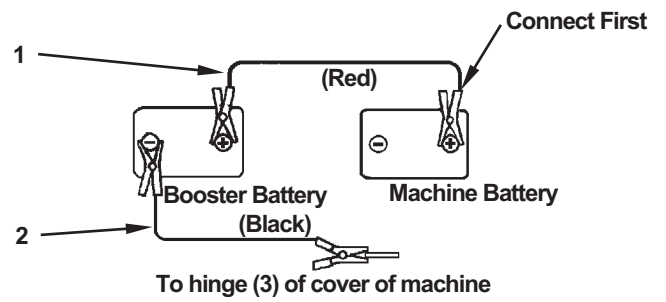

MAAA-03-003-1 en\_GB

## OPERATING THE ENGINE

---

### Stopping the Engine

#### Procedure for Stopping the Engine

1. Lower the bucket and the blade to the ground before stopping the engine, except in special circumstances.
2. Pull pilot control shut-off lever (1) to the LOCK position.
3. Put the engine control lever in the slow idle position and run the engine for 5 minutes to cool it.
4. Turn key switch (2) OFF to stop the engine.

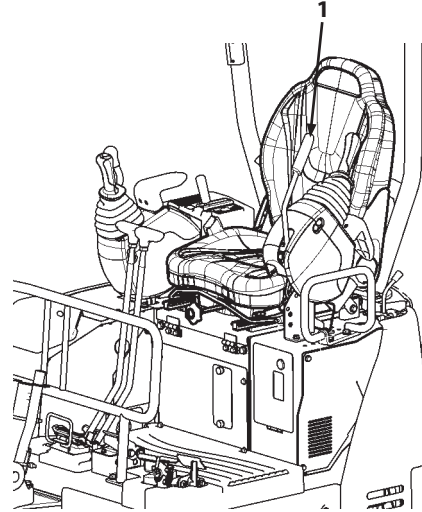

MABA-01-002-2 ja

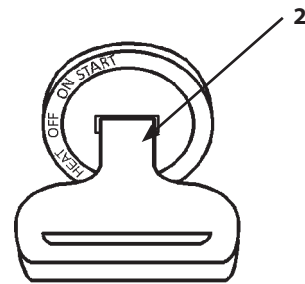

M1M7-01-007-1 ja

# DRIVING THE MACHINE

## Travel Lever (ZX17U-6, 19U-6)

### Travel Operation

The machine is controlled manually during travel via levers.

### WARNING

Normal travel operation is when travel motor (Mo) is at the rear and blade (Bl) is at the front of the machine.

If travel motor (2) is located at the front of the machine, the machine will move in the reverse direction to that shown on the operation instruction decal.

Check the position of travel motor (2) before travel.

### IMPORTANT

The arm and the bucket cannot be operated due to the structure of the hydraulic circuits when the travel lever is operated full stroke.

When complex operations are necessary, put the travel lever in an intermediate position and use other levers.

### NOTE

A travel lever damper is provided on this machine to ensure smooth travel operation. For that reason, the feel of the travel lever may be heavy in extreme cold (-20 °C or below). This is caused by an increase in oil viscosity, not a malfunction.

- Forward/Reverse Travel  
Push both left and right levers forward to drive the machine forward. Pull back on both levers to drive the machine in reverse. Travel speed can be controlled by how much the travel levers are operated.
- Slopes  
The maximum climbing ability of this machine is 25° (47%).  
Operate the travel levers slowly when descending a slope. When the travel levers are placed in the neutral position, brakes are automatically applied and the machine stops.

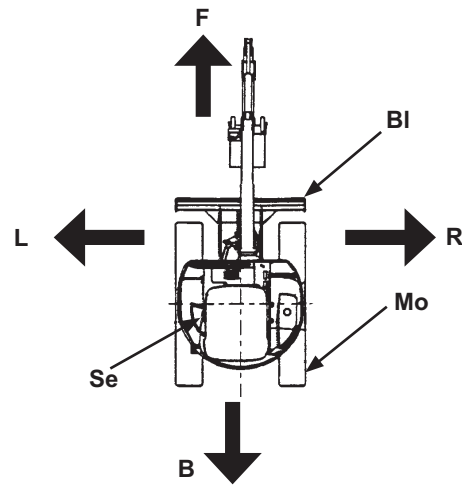

M571-01-001-4 ja

Bl:	Blade	B:	Back
Se:	Operator's Seat	R:	Right
Mo:	Travel Motor	L:	Left
F:	Forward		

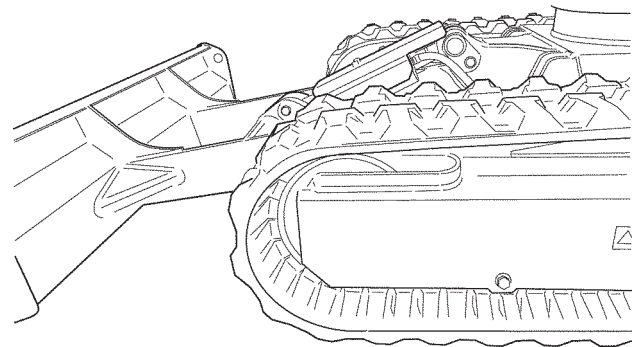

M1LA-04-001 ja

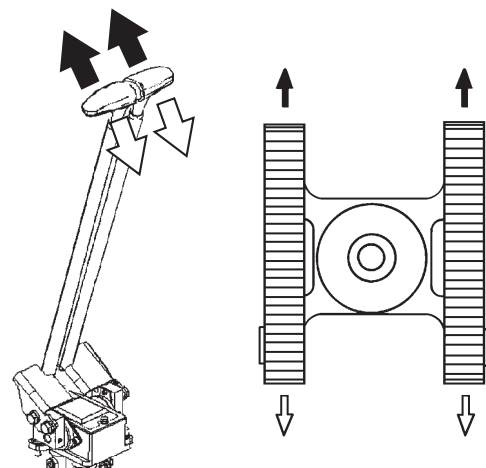

Forward/Reverse Travel

MABK-04-001 ja

## DRIVING THE MACHINE

- **Pivot Turn**  
The machine can be turned by driving just one of the two crawlers with either left or right travel levers.

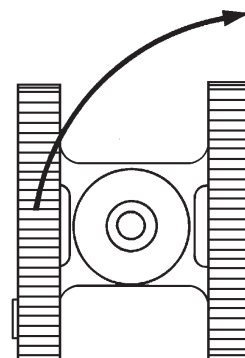
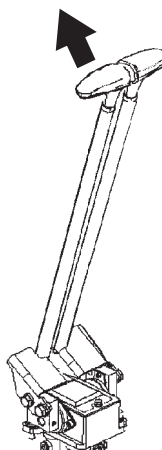

Pivot Turn

MABK-04-002 ja

- **Spin Turn**  
The machine can turn on a dime by driving the two crawlers in opposite directions to each other at the same time by pushing one lever forward and the other lever in reverse.

### CAUTION

**The machine may shake during pivot or spin turns. Pay close attention to the surroundings and proceed slowly when turning in tight places.**

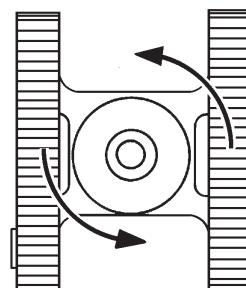
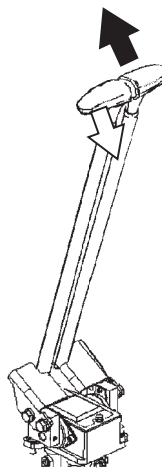

Spin Turn

MABK-04-003 ja



# DRIVING THE MACHINE

## Travel Levers and Pedals (ZX26U-6)

### Travel Operation

The machine can be controlled during travel with either the levers or the pedals.

### **!** WARNING

Normal travel operation is when the travel motor is at the rear, and the front idler is at the front of the machine. If the travel motors are located at the front of the machine, the machine will move in the reverse direction to that shown on the operation instruction decal. Check the position of travel motor before starting to travel.

### **Pencil** NOTE

A travel lever damper is provided on this machine to ensure smooth travel operation. For that reason, the feel of the travel lever or pedal may be heavy in extreme cold (-20 °C or below). This is caused by an increase in oil viscosity, not a malfunction.

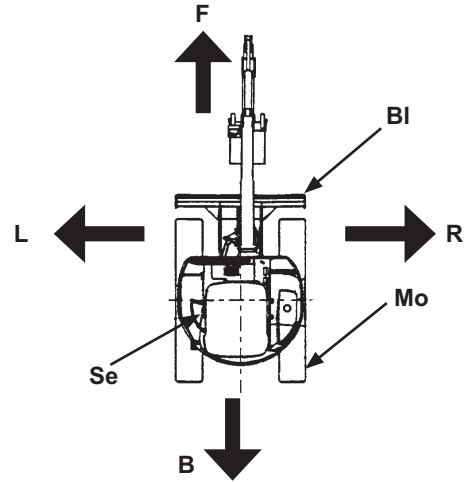

M571-01-001-4 ja

Bl:	Blade	B:	Back
Se:	Operator's Seat	R:	Right
Mo:	Travel Motor	L:	Left
F:	Forward		

- Forward/Reverse Travel**  
 Push both left and right levers (or both pedals) forward together to drive the machine forward. Pull both the levers (or pedals) rearward together to drive the machine in reverse. Travel speed can be controlled by the operation stroke of the travel levers and pedals.
- Slopes**  
 Never attempt to ascend or descend slopes steeper than 25° (47 %). Slowly operate the travel levers (or pedals) when descending a slope. When the travel levers (or pedals) are placed in the neutral position, brakes are automatically applied and the machine stops.

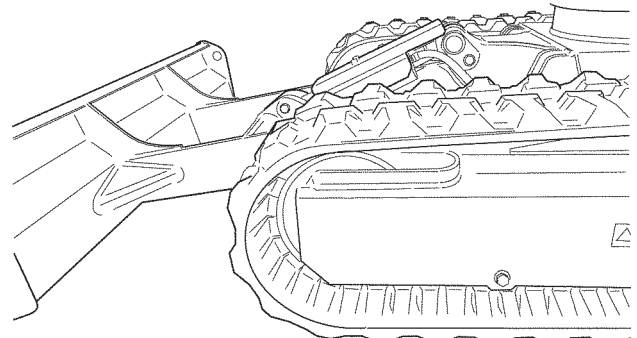

M1LA-04-001 ja

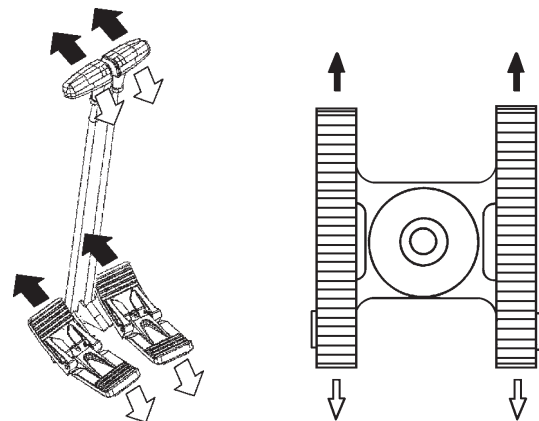

Forward/Reverse Travel

MABK-04-004 ja

## DRIVING THE MACHINE

 **NOTE**

The travel pedals on this machine can be folded away.  
Unfold the travel pedals to use them for travel.

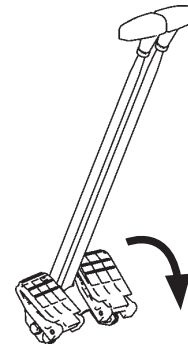

When Folded

M1M7-04-010-2 ja

- **Pivot Turn**  
The machine can be turned by driving just one of the two crawlers with either left or right travel levers (or pedals).

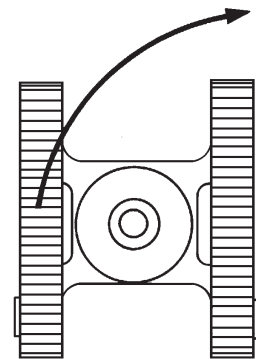
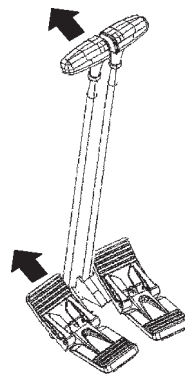

Pivot Turn

MABK-04-005 ja

- **Spin Turn**  
The machine can turn on a dime by driving the two crawlers in opposite directions to each other at the same time by pushing one lever (or pedal) forward and the other lever (or pedal) in reverse.

 **CAUTION**

The machine may shake during pivot or spin turns.  
Pay close attention to the surroundings and proceed slowly when turning in tight places.

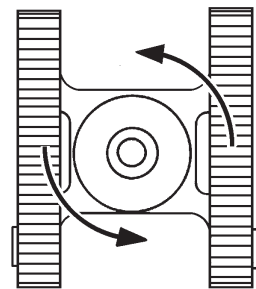
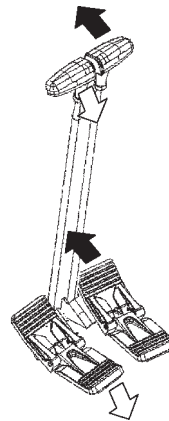

Spin Turn

MABK-04-006 ja

## DRIVING THE MACHINE

---

### Travel Mode Pedal (ZX17U-6, 19U-6)

#### **WARNING**

**Switching from low to high travel mode while traveling up/down a slope is extremely dangerous. To switch to high mode while ascending/descending a slope, first put both of the levers temporarily in neutral and then operate the mode pedal.**

Stepping on travel mode pedal (1) switches the mode to high only while it is depressed.

Once travel mode pedal (1) is released, it returns to low speed mode.

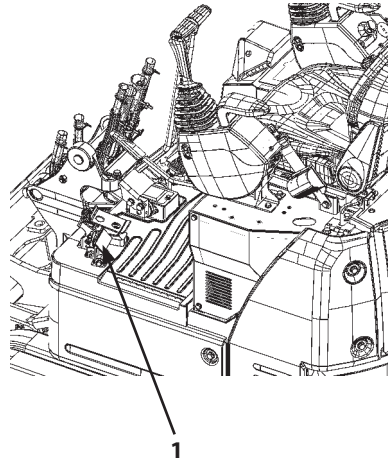

MABA-04-001-1 ja

## DRIVING THE MACHINE

### Travel Mode Switch (ZX26U-6)

#### WARNING

**Tipping-over accidents can cause serious personal injury. Do not change travel mode switch (1) while traveling; especially, changing to fast mode when descending slopes will create a very dangerous situation. Always stop the machine before changing the travel speed mode.**

When travel mode switch (1) is pushed while the machine is traveling at slow speed, the travel speed becomes high.  
Travel mode switch (1) lights.

When travel mode switch (1) is pushed while the machine is traveling at high speed, the travel speed becomes slow.  
Travel mode switch (1) turns OFF.

#### NOTE

*At low temperature, when the machine is traveling with travel mode switch (1) in the fast travel mode position, the slow travel mode may not automatically be selected even if the traveling loads increase. This is not abnormal. Drive the machine after conducting sufficient warm-up operation.*

*The slow travel mode is selected automatically if the traveling load increases.*

*The operation state of travel mode switch (1) is kept until the next time the machine is operated. When the engine is stopped in the high mode, the engine starts in the high mode next time.*

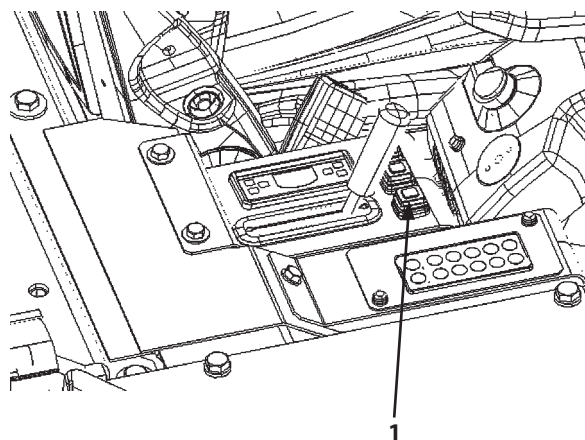

MABA-04-003-1 ja

## DRIVING THE MACHINE

### Traveling

#### **!** CAUTION

**When traveling in narrow areas, such as on the shoulder of a road, use someone to provide guidance.**

- Before moving the machine, check the direction of the undercarriage (position of the travel motor) and then operate the travel lever or pedal.
- Select as flat a path as possible when moving the machine. When changing direction, do so in a large arc; when small changes are required, make multiple small changes.
- Check the strength of bridges and road shoulders and reinforce them as necessary.
- Use planks to avoid damaging the surface of paved roads when using steel shoes. Pay particular attention in the summertime when traveling on or changing directions on asphalt roads.
- When crossing railroad tracks, take steps such as putting down wood boards to avoid putting all the weight on just the rails.
- Before driving under obstructions such as the girders of bridges and power lines, check their height so you do not touch them.
- When crossing streams or rivers, use the bucket to check the condition of the stream bed as you go and proceed cautiously. Never enter water that is deeper than the allowed depth.
- Traveling across rough terrain imposes severe shocks to the frame of the machine. Lower the engine speed and proceed slowly.
- Do not allow rolling stones to hit the travel motor. Avoid driving in such a way that puts excessive force on the treads, such as trying to drive over obstructions.
- When driving on snowpack or icy roads, or when loading/unloading the machine for transport, take steps to prevent slipping due to clogged shoes.

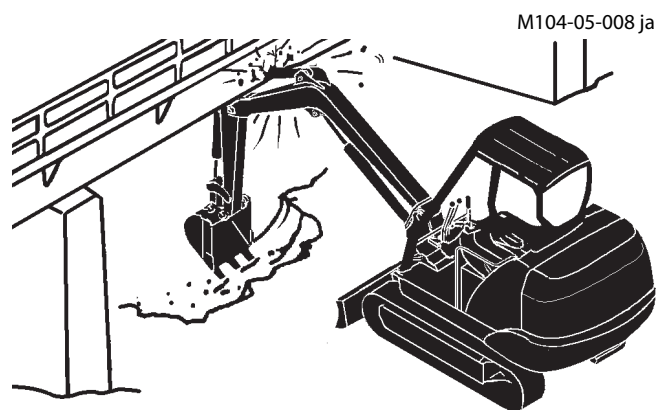

SA-673 ja

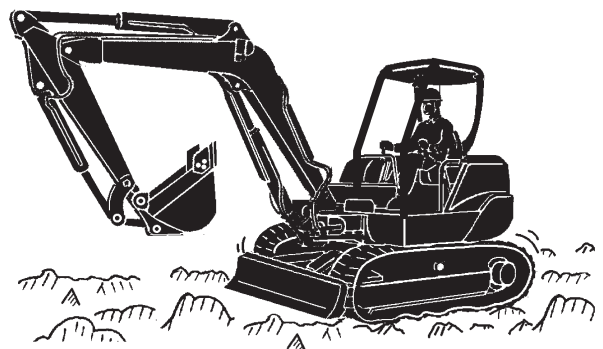

M586-05-002 ja

## DRIVING THE MACHINE

### Traveling on Soft Ground

Avoid operating on soft ground as much as possible. When it is unavoidable, operate carefully and observe the following points.

- Operate only as far as it can travel under its own power. Do not go in so far that the machine cannot be towed out, in the worse case scenario.
- If the machine can no longer move, put the bucket on the ground and use the boom and arm functions to pull the machine toward firm ground. When doing so, operate the boom and arm at the same time as the travel lever to avoid applying excessive force.
- If the belly of the machine is high-centered, or if the undercarriage is blocked by mud and/or gravel, use the boom and arm to support the machine and lift up one side of the tracks at a time. Clear the mud and/or gravel so the machine can get out. Rotating the raised track back and forth in turn can clear it of stones and mud.
- If the machine sinks into soft ground and cannot get out on its own, tow it with another machine. For how to fasten wire ropes when doing so, refer to the section "Towing the Machine".

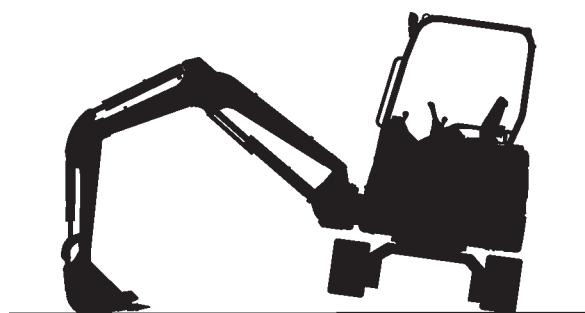

M1M7-04-005 ja

### Raising One Track Using the Boom and Arm

#### WARNING

The machine may slip sideways. Be careful during this operation. Keep the angle between boom and arm 90 to 110°.

1. Swing the upperstructure so it is 90° to the tracks.
2. Keep the angle between the boom and arm 90 to 110° and position the bucket's round bottom on the ground.
3. Do not raise the machine using the boom and arm while it is swung.
4. Place supports, such as blocks, under the frame to support the machine.

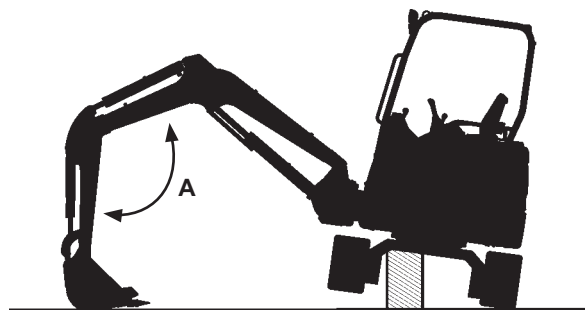

A: 90 to 110°

M1M7-04-006-1 ja

## DRIVING THE MACHINE

### Towing the Machine

If the machine cannot get out of soft ground on its own, attach wire ropes (1) as shown in the diagram at right and tow it out with another machine.

When attaching wire ropes (1), attach them to the frame.

Place protective material (2) at corners to prevent damage to wire ropes (1).

#### CAUTION

- **Some machines have a bracket on the track frame for attaching a shackle and towing light weight objects.**
- **Do not use this bracket for towing light objects to tow the machine. Doing so will damage the towing bracket.**
- **Refer to the section Using the Bracket for Towing Light Objects in Chapter 5 Operating the Machine for instructions on using the bracket.**
- **Do not tow the machine with the holes in the blade designed for hoisting the entire machine. Doing so will damage the hoisting holes.**

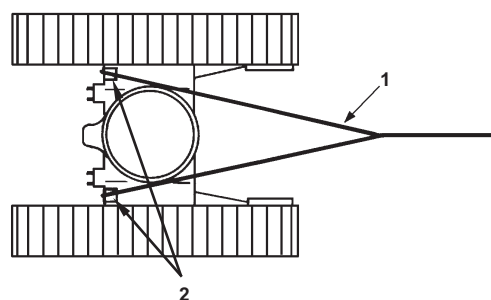

M585-05-035-1 ja

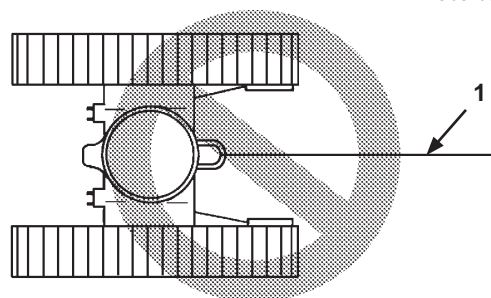

MZX5-04-006-1 ja

## DRIVING THE MACHINE

### Operating in Water or Mud

The work footing must be strong enough so the machine does not sink. If there is a slight current, the allowable depth of water is up to the top of the shoe at the idler.

When working under such conditions, check the state of the machine constantly. Move the machine if needed.

Do not allow the swing bearing, swing gear or center joint to be immersed in water, sand or mud.

#### IMPORTANT

**If the swing bearing, swing internal gear and center joint are submerged, remove the drain plug to drain mud and water. Clean the swing area. Install the plug. Lubricate swing internal gear and swing bearing. The grease must be replaced immediately or the parts disassembled and serviced. Stop driving the machine and consult your authorized dealer.**

	Allowable depth: A
ZX17U-6, 19U-6	370 mm
ZX26U-6	460 mm

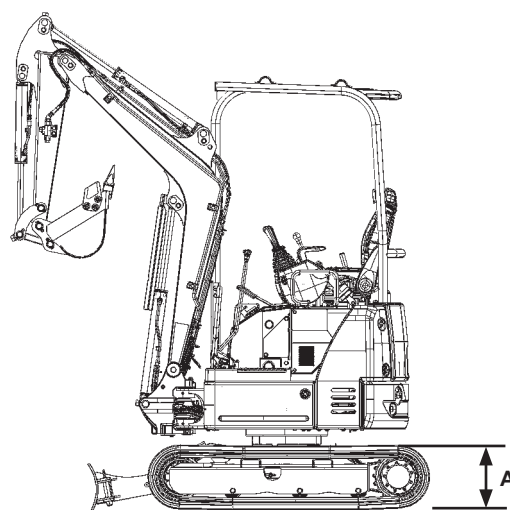

Operating in Water or Mud

MABA-04-002-1 ja



## DRIVING THE MACHINE

### Precautions for Traveling on Slopes

#### CAUTION

Beware of any personal injury from traveling on slopes. This may be caused by the machine tipping over or sliding sideways. Fully read and understand the following precautions and keep the speed down while traveling on sloping ground. Do not travel with the bucket loaded or a load suspended from it. Travel with the tracks at their fully extended width if using a variable leg specification machine. If the full width of the track is shortened, the machine is more likely to tip over.

- Never attempt to travel on slopes steeper than 25 ° under any circumstances.
- Always fasten the seat belt when traveling on slopes.
- Keep the bucket 200 to 300 mm (A) above the ground when traveling on sloping ground. If the machine slips or becomes unstable, immediately lower the bucket to the ground and stop traveling.

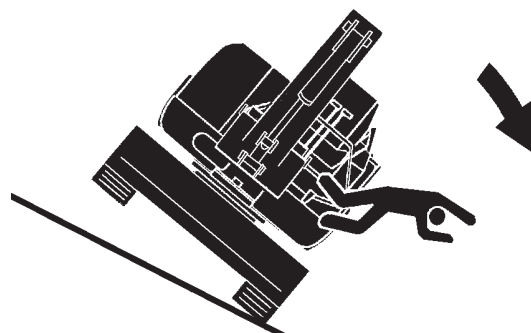

SA-264 ja

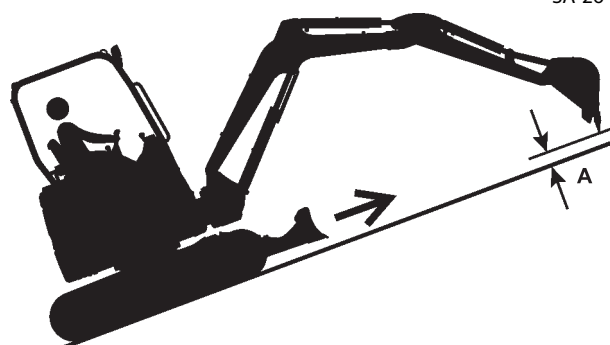

SA-1295-1 ja

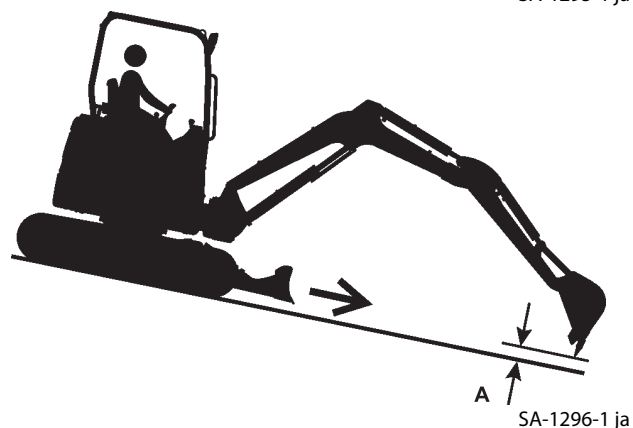

SA-1296-1 ja

## DRIVING THE MACHINE

---

- The machine is at risk of sliding sideways and/or overturning if the machine is turned or driven diagonally across a slope. Descend for a moment to level ground and turn or make other operations in a safe way.
- Do not swing while on sloping ground. In particular, never swing downhill while on sloping ground. Doing so may cause the machine to tip over. If swinging uphill, perform any swing or boom operations slowly and carefully.
- If the engine stalls while on sloping ground, put all levers in neutral before restarting the engine.
- If the hydraulic oil is not warmed up, the machine may not achieve its full climbing ability. Warm up the machine fully before climbing a steep slope.

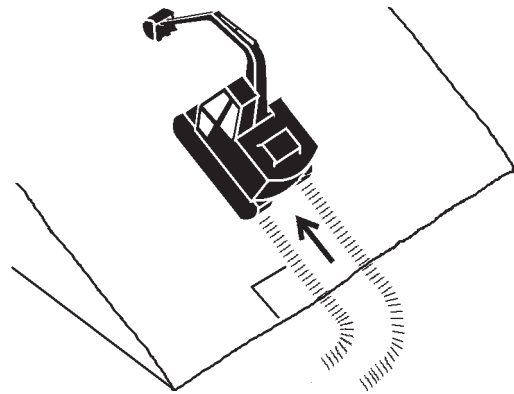

SA-441 ja

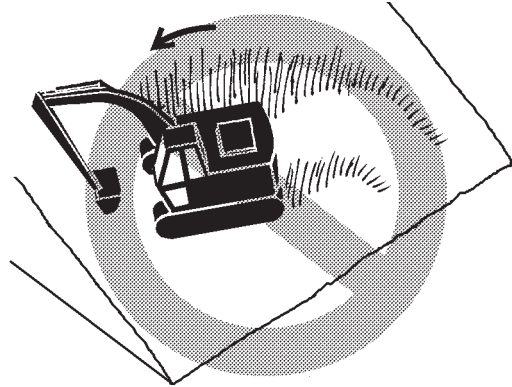

MZX5-04-002 ja

## DRIVING THE MACHINE

### Parking the Machine on Slopes

#### **⚠ WARNING**

**Avoid parking the machine on slopes. The machine may tip over, potentially resulting in personal injury.**

If parking the machine on a slope is unavoidable:

- thrust the bucket teeth into the ground.
- Return the control levers to neutral and pull pilot control shut-off lever (1) up to the LOCK position.
- Block the tracks.

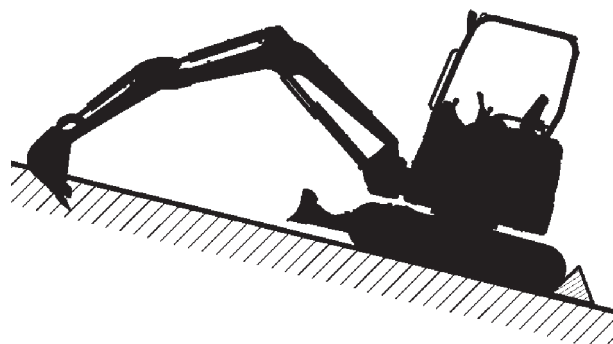

M1M7-04-009 ja

### Parking

1. Stop the machine on a firm, level surface.
2. Lower the bucket and the blade to the ground.
3. Return the engine control lever to the slow idle position and run the engine for approximately 5 minutes to cool the engine.
4. Turn key (2) to OFF to stop the engine and remove the key.
5. Pull pilot control shut-off lever (1) to the LOCK position.
6. For machines with a cab, always close windows and the cab door when leaving the machine.
7. Close all doors and covers, and lock them.

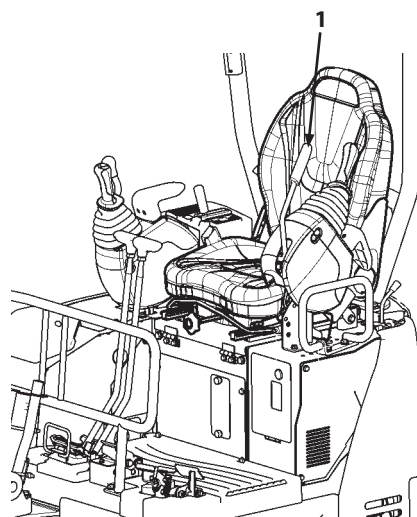

MABA-01-002-2 ja

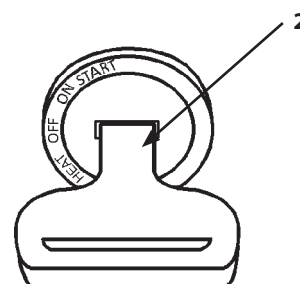

M1M7-01-007-1 ja

## DRIVING THE MACHINE

---

MEMO

# OPERATING THE MACHINE

## Control Lever (ISO Pattern)

### **! WARNING**

- Never place any part of the body beyond the window frame. It could be crushed by the boom if the boom control lever is accidentally bumped or otherwise engaged. Never remove the window sash bar.
- Make sure you know the location and function of each control before operating it.
- Do not change the control lever operation pattern. Failure to follow this instruction may result in misoperation of the machine.

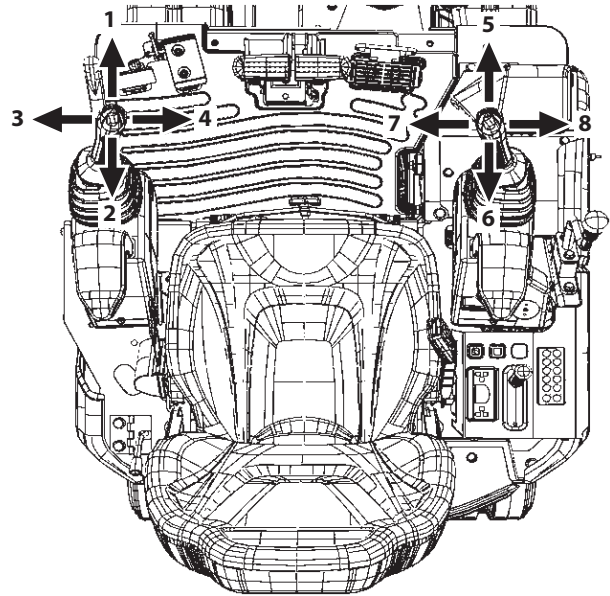

MABA-05-001-1 ja

A label showing the control patterns of the levers and pedals is attached on the right side in the cab.

When a lever is released, it automatically returns to neutral, and that machine function stops.

- 1- Arm Roll-Out
- 2- Arm Roll-In
- 3- Swing Left
- 4- Swing Right
- 5- Boom Lower
- 6- Boom Raise
- 7- Bucket Roll-In
- 8- Bucket Roll-Out

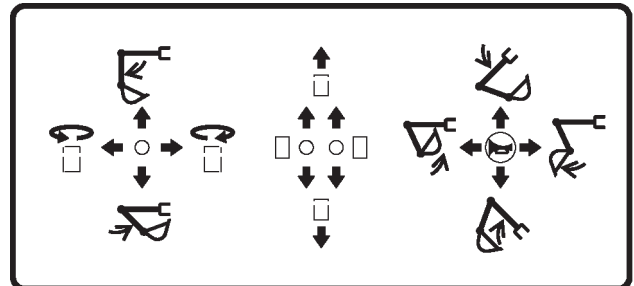

MABA-05-016 ja

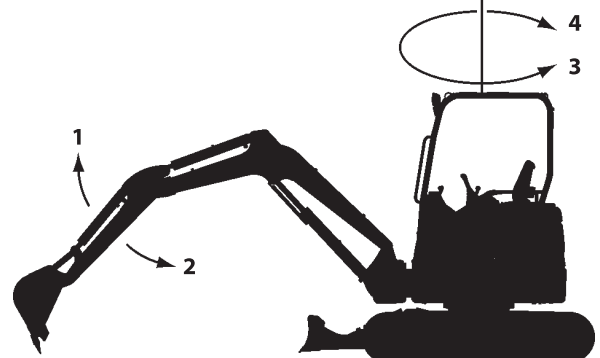

M1M7-05-001-1 ja

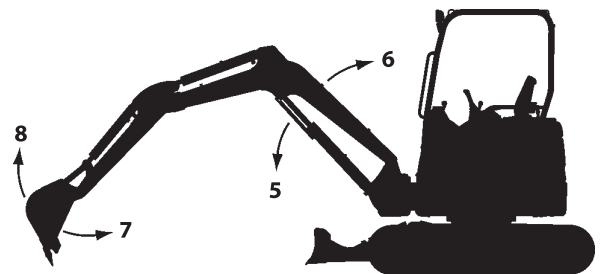

M1M7-05-002-1 ja

# OPERATING THE MACHINE

## Boom Swing Pedal

Using the swing mechanism is convenient when digging ditches along roads or along walls. The boom swing is operated with boom swing pedal (1) at the right front of the operator's seat as shown in the diagram at right.

### Boom Swing Operation

1. Lower cover (2) of boom swing pedal (1).
2. Depress the left part of boom swing pedal (1) to swing the boom to the left, or the right part of the pedal to swing the boom to the right.

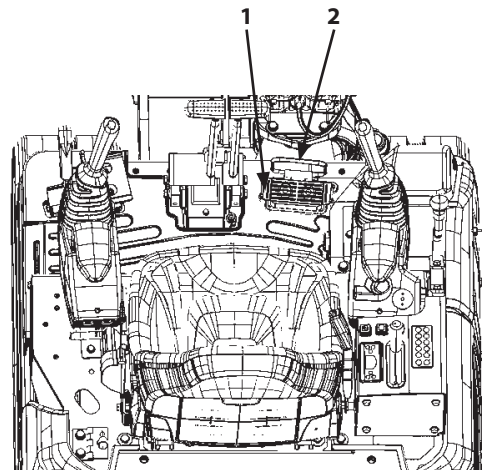

UNLOCK Position

MABA-05-002-1 ja

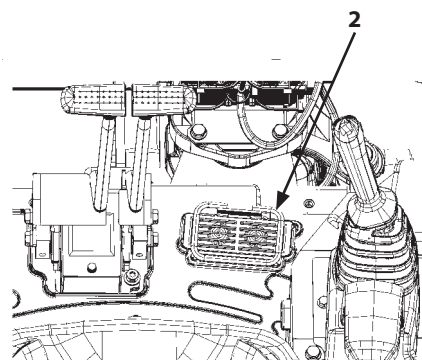

LOCK position

MABA-05-003-1 ja

3. When not using boom swing pedal (1), lower cover (2) to the front and cover it.
  - 3- Left swing
  - 4- Right swing

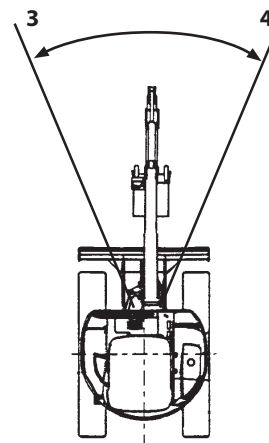

MABK-05-002-2 ja

## OPERATING THE MACHINE

### Blade Lever

The blade is operated with blade lever (1) on the right side of the operator's seat as shown in the diagram at right. Letting go of blade lever (1) returns the lever to its neutral position, allowing the blade to maintain its position until lever (1) is operated again.

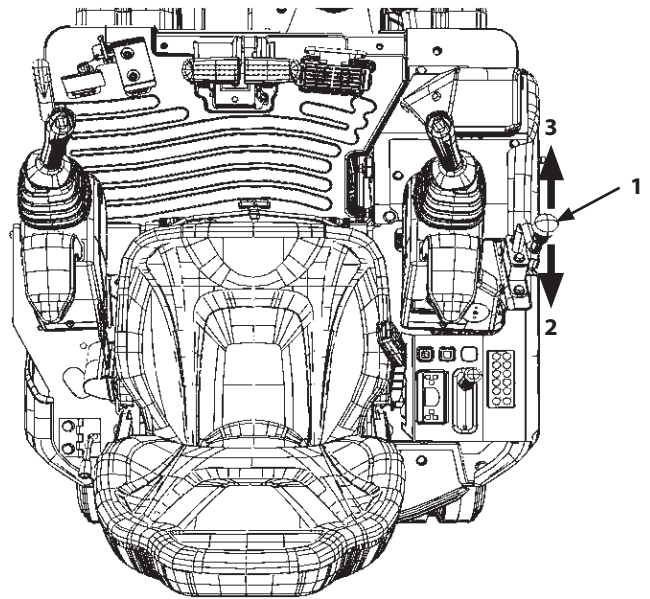

MABA-05-001-2 ja

- 2- Blade up
- 3- Blade down

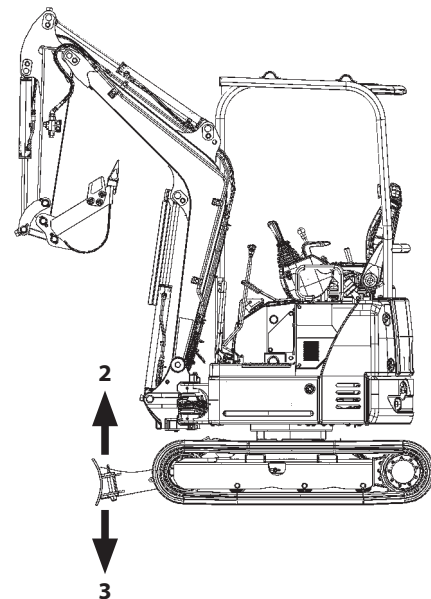

MABA-04-002-2 ja

## OPERATING THE MACHINE

### Precautions for Blade Operation

This blade is a simple blade designed exclusively for use with a mini excavator. So, follow the precautions below and handle with all due care.

- This blade is exclusively for simple bulldozing out. Do not do any extreme digging with the blade. Doing so may cause damage to the blade and/or undercarriage.
- Do not put concentrated or off-center loads on the blade. Also, crashing into anything while traveling is strictly prohibited. Doing so may damage the blade and/or undercarriage.
- Be careful when the machine is lifted as the pressure on the ground will be extremely localized, making it prone to collapse. To lift the machine using this blade, first make sure the ground is strong enough to support it. Make sure the bottom of the blade touches the ground evenly so no concentrated or off-center loads are applied to the blade.
- When excavating to the front with the blade, the bucket may interfere with the blade. Take care to avoid this.
- The boom cylinder may interfere with the blade when digging deep with the boom. Take care to avoid this.

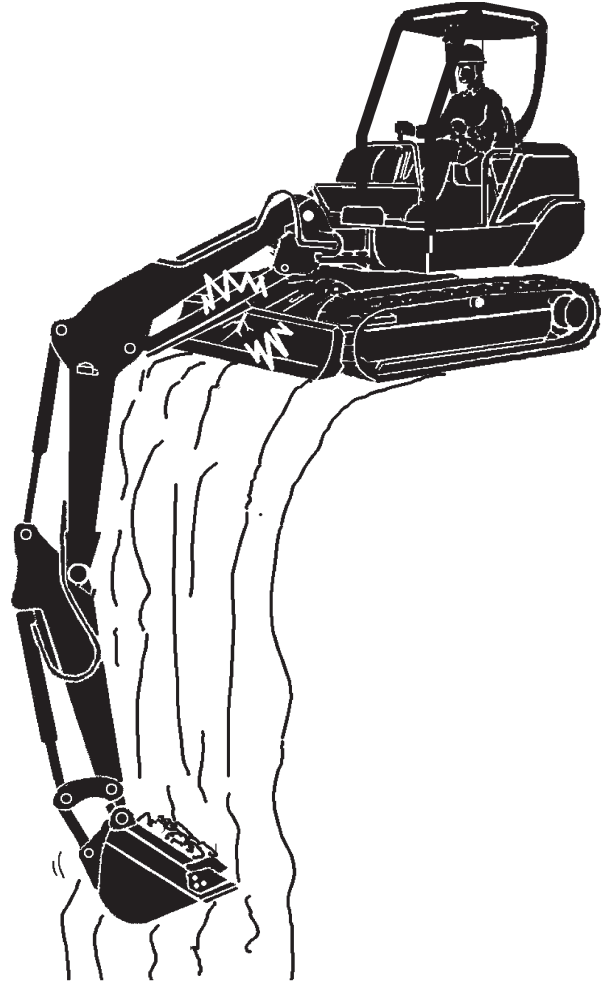

M586-05-016 ja

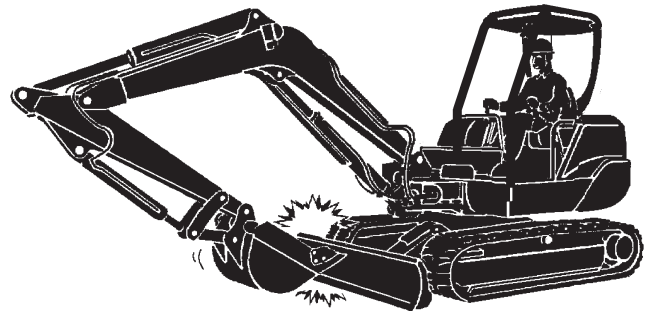

M586-05-017 ja



## OPERATING THE MACHINE

### Side Frame Extend/Retract Lever (ZX17U-6, 19U-6)

To extend or retract the track width, use side frame extend/retract lever (1) as shown in the figure at right.

#### **WARNING**

Set it to either fully extended track width (1280 mm) or fully retracted width (980 mm). If extension/retraction is stopped part way, the upperstructure becomes wobbly as the track width is not fixed.

The track width should only be retracted to its narrowest when passing through a flat, narrow place. Fully expand the track width at all other times--prior to travel, digging and blade work. Being at its narrowest track width may cause the machine to tip over.

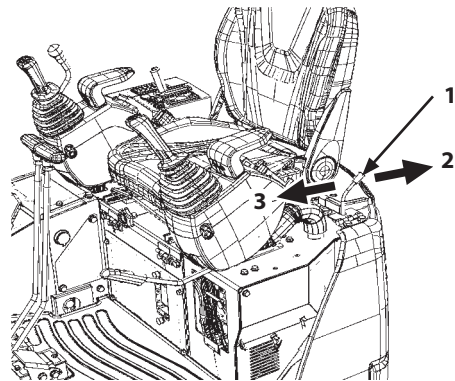

MABA-05-004-1 ja

#### **IMPORTANT**

Start extending/retracting the track width after moving the machine to a flat area with no obstacles. Also, remove any mud, gravel or the like clogging the expanding/retracting parts.

#### **Operation of the Side Frame Extend/Retract Lever**

1. Extension of Track Width  
Pull back on side frame extend/retract lever (1) to extend the track width.
  2. Retraction of Track Width  
Push side frame extend/retract lever (1) forward to retract the track width.
- 2- Track Width Extension  
3- Track Width Retraction

## OPERATING THE MACHINE

### Extending/Retracting Blade Width

Change the width of the blade to match the extension/retraction of track width. It may be difficult to perform this task with the blade set on the ground. Lift the blade and stop the engine before doing this task.

#### When Extending the Blade Width:

1. Pull out blade pin (5).
2. Flip out extension blade (4) and line up the pin holes.
3. Insert blade pin (5).
4. Follow steps 1 to 3 for the right side as well.

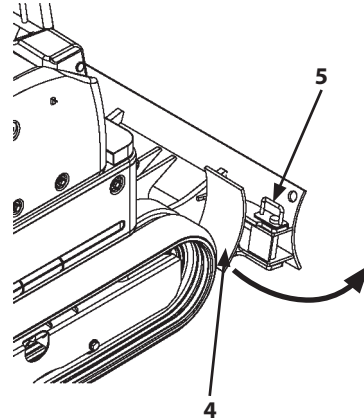

MABA-05-014-1 ja

#### When Retracting Blade Width:

1. Pull out blade pin (5).
2. Fold extension blade (4) away so its cutting edge is facing the rubber shoes. Then line up the pin holes.
3. Insert blade pin (5).
4. Follow steps 1 to 3 for the right side as well.

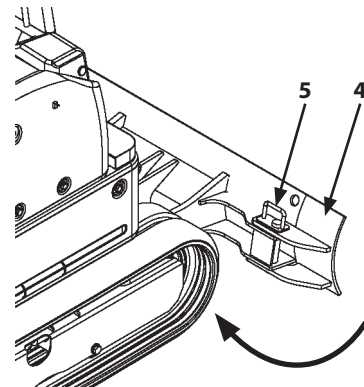

MABA-05-015-1 ja

# OPERATING THE MACHINE

## Pilot Control Shut-Off Lever

Pilot control shut-off lever (1) functions to prevent misoperation of the machine if control levers (3) or pedals are accidentally moved when leaving the operator's seat or when entering the cab. In addition, pilot control shut-off lever (1) is linked with a lifting mechanism for console (2) that facilitates getting on/off the machine and inspections and maintenance.

### WARNING

- To lock control levers (3) and the pedal, lift up pilot control shut-off lever (1) and console (2) completely to their LOCK positions. In the LOCK position, do not unlock while holding console (2) and control levers (3).
- When operating pilot control shut-off lever (1), be careful not to touch control levers (3). If the machine moves unexpectedly, it may cause a serious accident.
- When leaving the machine, always stop the engine and then pull pilot control shut-off lever (1) up to the LOCK position.
- Make sure it is in the LOCK position before transporting the machine or leaving the machine at the end of a shift.

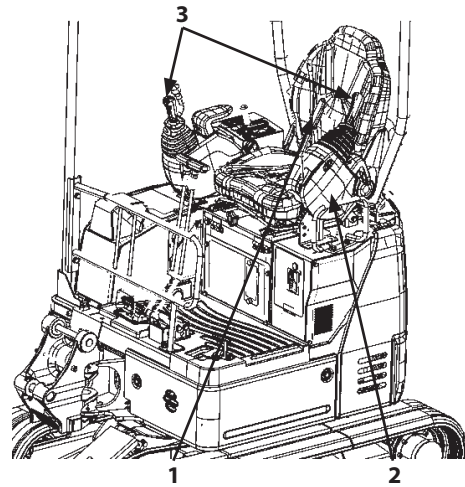

LOCK position

MABA-05-005-1 ja

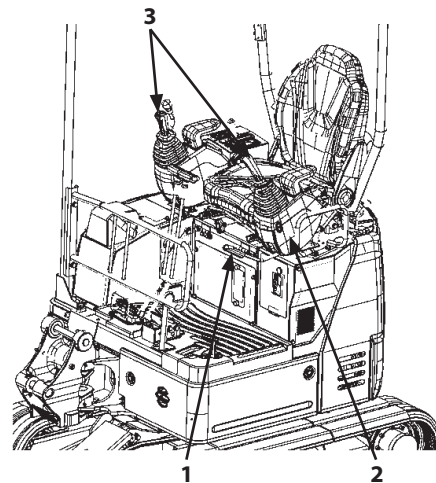

UNLOCK Position

MABA-05-006-1 ja

### Before Leaving the Machine

1. Park the machine on a firm, level surface. Lower the bucket and blade to the ground. Return all control levers to neutral. Properly shut down the engine.
2. Lift pilot control shut-off lever (1) and console (2) fully to their LOCK positions.

## OPERATING THE MACHINE

---

### Before Starting Work

Confirm that pilot control shut-off lever (1) is pulled up to the LOCK position before starting the engine.

Slowly push down pilot control shut-off lever (1) to the UNLOCK position before starting operation.

Confirm that all control levers and pedals are in neutral and that no part of the machine is in motion.

### WARNING

**If all the levers and pedals are in neutral and just putting pilot control shut-off lever (1) in the UNLOCK position causes any part to move, the machine is malfunctioning. Immediately pull pilot control shut-off lever (1) back to the LOCK position, and stop the engine. Consult the nearest Hitachi representative.**

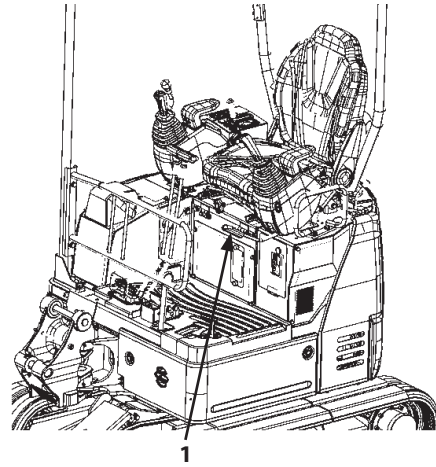

UNLOCK Position

MABA-05-006-2 ja

## OPERATING THE MACHINE

### Warming-Up Operation

The normal operating temperature of hydraulic oil is between 50 and 80 °C. Hydraulic components may be seriously damaged if the machine is operated when the hydraulic oil temperature is below 20 °C.

Before starting work, be sure to follow these warm-up procedures until the temperature of the hydraulic oil reaches above 20 °C.

#### Warming-Up Procedure

1. Put engine control lever (1) in the low idle position.  
(Do not operate the machine until the light of coolant temperature indicator (2) goes out.)
2. Once coolant temperature indicator (2) goes out, put engine control lever (1) near the middle and run the engine for 5 to 10 minutes.
3. After warming up the hydraulic oil, slowly operate each cylinder back and forth several times and gently operate the swing and travel to warm up the motors and actuators.

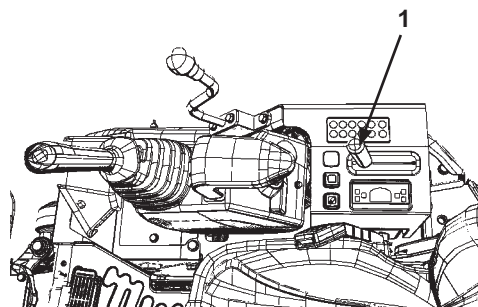

MABA-01-005-6 ja

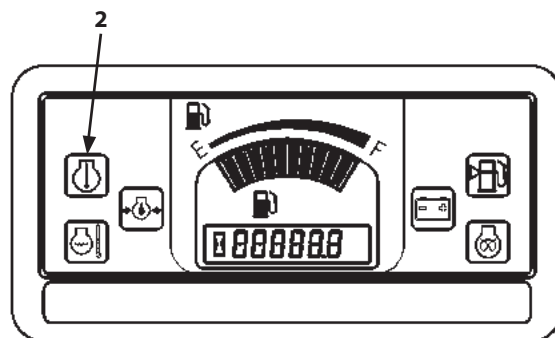

M1NC-01-005-5 ja

#### Warming Up in Cold Weather

#### IMPORTANT

**When the oil is cold, perform the warm-up operation and wait until operating speed is normal before operating the machine.**

1. Run the engine at a medium speed for 5 minutes. Run the engine at medium speed for longer to warm the machine when it is extremely cold.
2. At such time, do not run the engine at high or low speed.
3. After warming up the hydraulic oil, slowly operate each cylinder back and forth several times and gently operate the swing and travel to warm up the motors and actuators.
4. Extend the bucket cylinder to stroke end.  
When doing so, do not continue operating the bucket for over 30 seconds.
5. Contract the bucket cylinder to stroke end.  
When doing so, do not continue operating the bucket for over 30 seconds.
6. Repeat steps 4 and 5 above until the bucket cycle time is normal.

## OPERATING THE MACHINE

---

### Operating Backhoe

- Use the appropriate arm and bucket for the work. (Refer to "Bucket Types and Applications" in Chapter 12, "Specifications".)
- Pull the bucket toward the machine using the arm as the main digging force.
- When soil sticks to the bucket, remove it by moving the arm and/or bucket back and forth.
- Stand the teeth on the ground with the bottom of the bucket at an angle of 45° to the ground.
- When trenching a straight line, position the tracks parallel to the trench. After digging to the desired depth, move the machine as required to continue the trench.
- Leave some room when digging to avoid bottoming the cylinder and prevent cylinder damage.

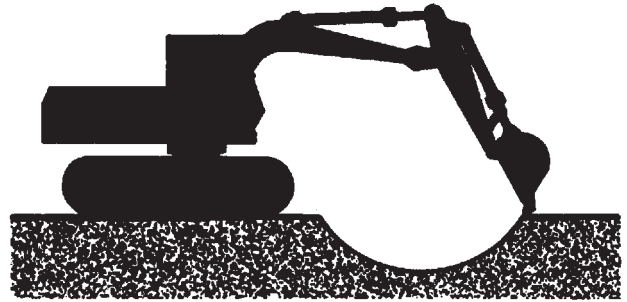

M107-05-037 ja

### IMPORTANT

- **When digging at an angle, avoid striking the tracks with the bucket teeth.**
- **When lowering the boom, avoid stopping suddenly as this will shock the machine. Lower the boom smoothly to avoid shocking the machine.**
- **When digging deep, avoid striking the boom cylinder, boom bottom or bucket cylinder hoses against the ground.**
- **When excavating in the direction of the blade, take care to avoid the bucket teeth coming in contact with the blade.**
- **When the bucket load is dumped with the boom raised, falling material may hit the base of the machine. Always be aware of loads in the bucket during operation.**

## OPERATING THE MACHINE

---

### Grading Operation

Use the blade for soil refilling and general grading operations after excavation. Grading can be also performed by operating the boom, arm, and bucket in tandem with each other.

#### **IMPORTANT**

**When grading with a bucket, do not use it like a bulldozer. Excess force will be applied on its parts, and the machine may be damaged.**

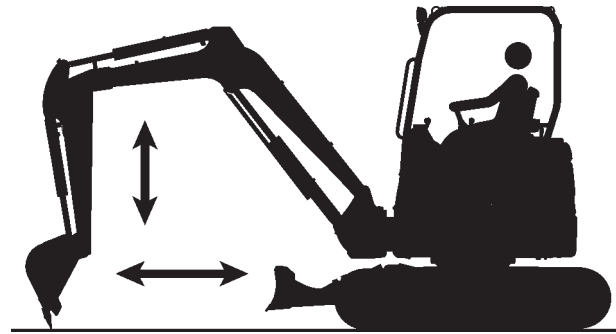

M1M7-05-012 ja

#### **To grade by operating the boom, arm, and bucket simultaneously:**

1. When leveling ground toward the machine, roll the arm in gently while lifting the boom up. Once the arm moves past the vertical position, slowly lower the boom to allow the bucket to maintain a smooth surface.
2. Reverse the directions in step 1 to perform arm roll-out grading.

Perform slope finishing work using the same procedures described for face finishing work.

## OPERATING THE MACHINE

---

### Avoid Abusive Operation

Do not attempt to add additional digging force by using travel, or raising the rear of the machine to use the machine's weight.



MZX5-05-002 ja

### Never Swing the Machine or Boom to Work

Do not use force from swinging the upperstructure or the boom to move rocks or debris out of the way or do demolition work by striking a wall with the side of the bucket. Doing so may damage the front-end attachment and the swing system.

### Avoid Driving Bucket Teeth into Ground

#### **WARNING**

**Forcibly striking the bucket teeth on the ground may result in personal injury from flying debris. It will also shorten the service life of each part on the front attachment.**

If the bucket teeth are forcibly struck on the ground, it shortens the service life of the front-end attachment parts (especially the bucket).

When digging a hard gravel layer, use the upwards digging force of the bucket. Operate the boom, arm and the bucket simultaneously so that the bucket teeth bite efficiently into the ground.

Flying debris may result in personal injury.



## OPERATING THE MACHINE

---

### Never use as a Hammer

#### **WARNING**

As the bucket body has a curved surface, hammer work or piling work is very dangerous. Doing so may damage the bucket and front attachment.

Do not attempt to use the bucket for hammering or piling work.

Doing so may damage the bucket and front attachment, causing personal injury. It is also dangerous, so do not do it.

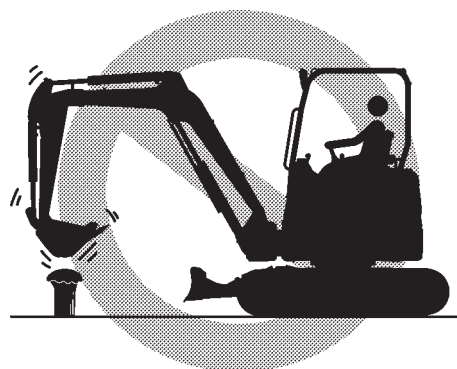

MZX5-05-001 ja

### Boom Cylinder may Hit Blade

When working with the blade in front, be careful not to hit the boom cylinder and/or the bucket on the blade.

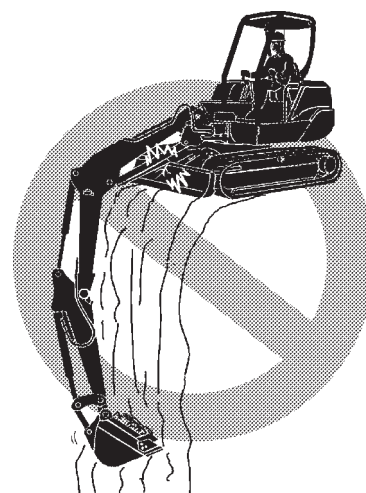

MZX5-13-014 ja

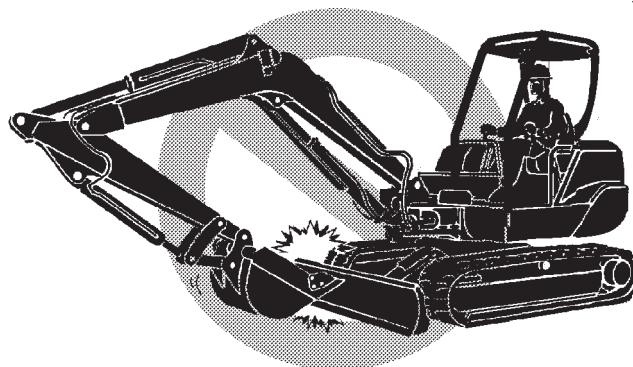

MZX5-13-015 ja

## OPERATING THE MACHINE

---

### Avoid Hitting Blade With Bucket

When the front end is rolled in for travel or transport, be careful not to hit the blade with the bucket.

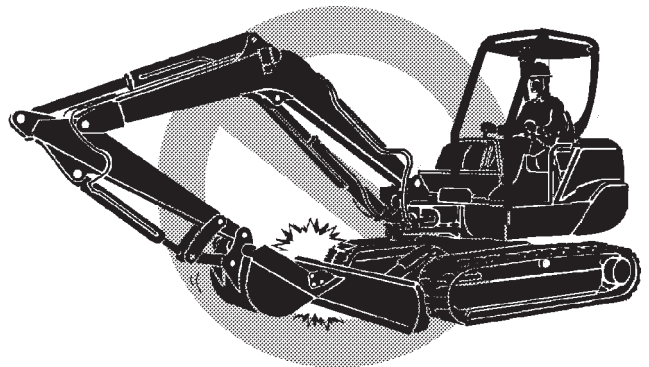

MZX5-13-015 ja

### Avoid Colliding Blade Against Rocks

Avoid hitting rocks with the blade. Premature damage to the blade and/or cylinders will result.

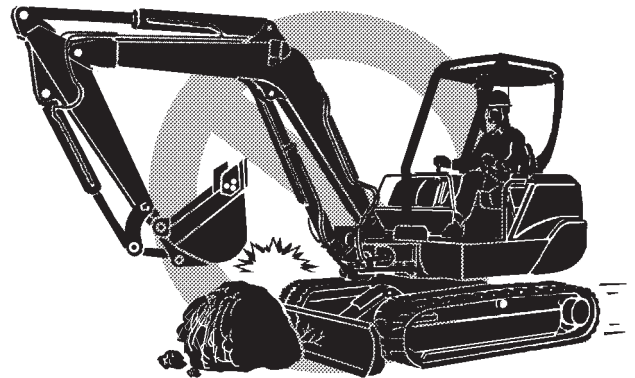

MZX5-13-016 ja

### Avoid Colliding Boom Cylinder With Track

When excavating with the front end swung to the side, as in the illustration, be careful to avoid hitting the tracks with the boom cylinder.

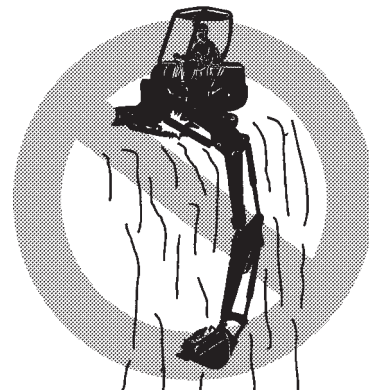

MZX5-13-018 ja

## OPERATING THE MACHINE

---

### Precautions for Installing Wide Bucket or Special Type Bucket

If the boom is fully offset to the left and raised on a cab-equipped machine with a bucket wider than shown to the right installed, the bucket will come in contact with the cab. Be sure to install a specially arranged bucket only after consulting your authorized dealer to prevent the cab collision with the bucket.

ZX26U-6: 550 mm

### Use the Right Shoes for the Site

Never use rubber crawlers or wide track shoes on rough terrain with scattered rocks, gravel or boulders. Doing so may break rubber crawlers, bend shoes and/or loosen shoe bolts, and may damage other undercarriage components, such as track links and rollers. (Refer to "Shoe Types and Applications" in the Specifications section.)

Soil may easily become packed into the crawler during travel on sandy ground. If the machine is driven without removing the packed soil, excessive force is exerted on the rubber crawlers, which may break them. Avoid the crawlers becoming packed with soil by removing soil as often as possible.



M1M7-05-015 ja

## OPERATING THE MACHINE

### Using Rubber Crawler

Rubber crawlers were designed to prevent damage to roads, such as paved surfaces. Be careful in handling them and follow the precautions and prohibited uses indicated below.



M1M7-05-015 ja

### Prohibited Work

1. Do not work or change directions in and around flood plains, on ground made up of rocks, stones and rubble, on extremely rough and hard bedrock, stumps, rebar, scrap iron, or edges of iron plate; doing so significantly shortens the service life of the rubber crawlers.
2. Do not leave engine oil, fuel, and other kinds of lubricants on the rubber crawlers, and avoid traveling on road surface covered with oil to reduce the risk of sliding.
3. If the rubber crawler on one side is raised with the boom, arm or bucket, and the rubber crawler on the other side moves, it dislocates and may damage it, so do not do this.

### Driving and Other Precautions

#### WARNING

**Rubber crawlers are less stable than iron crawlers because the ends of the rubber bend. Be particularly careful when working to the sides.**

1. Avoid storing the machine in a location where direct sunlight will hit the crawlers for 3 months or longer.
2. Avoid unnecessary steering on concrete road surfaces as this prematurely wears the shoe lugs and core metal. Also, avoid operating the machine on hot (over 60 °C) road surfaces during asphalt pavement work, as this causes premature wear and may damage the road surface.

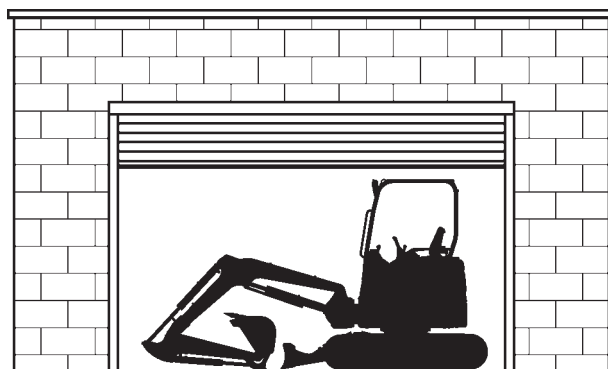

M1M7-05-016 ja

## OPERATING THE MACHINE

---

3. Operating the machine with loose rubber crawlers on uneven surfaces may force the rubber crawlers off the rollers and damage them.

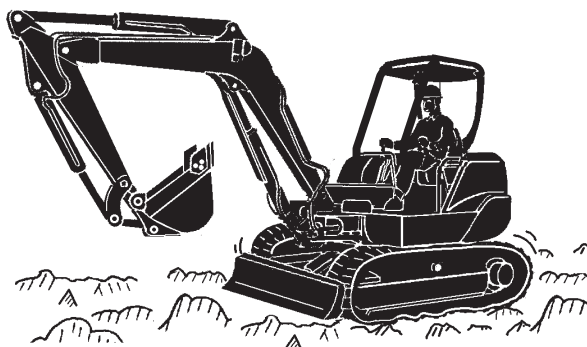

M586-05-024 ja

4. When the machine is raised with an attachment, lower it gently back down.
5. When new, rubber crawlers (3) have a thin rubber film (indicated by dotted line) (2) on the surface that contacts rollers (1). It is normal for this rubber film to come off due to contact with rollers (1) when the machine is new or immediately after crawler replacement. (Refer to illustration at right)
6. If rubber crawlers (3) are damaged and the wire inside the crawler rusts, it shortens its service life. It must be repaired if damaged. Consult your authorized dealer.

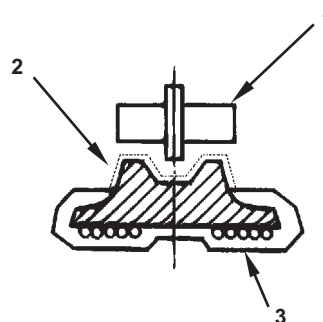

M503-05-040-1 ja

## OPERATING THE MACHINE

---

### Never Use Other than as Specified

**This machine is designed for excavating and loading.**

Do not use it for any other purpose. Do not operate it beyond the specifications indicated.

### **WARNING**

#### **Precautions for Lifting Work**

- **Work on level ground. Working on a slope is dangerous as the machine may become unstable.**
- **When swinging the machine with a load, be careful not to hit anyone nearby with the load and take care not to tip the machine over due to centrifugal force. Reduce engine speed to low and swing at a slow rate.**
- **If traveling with a load is unavoidable, adjust the engine speed to slow and travel slowly.**
- **Never move the front end or swing the machine while traveling as making the load sway is dangerous.**

## OPERATING THE MACHINE

### Using the Towing Bracket on the Track Frame

Some machines have a bracket on the track frame for attaching a shackle and towing light weight objects.

#### IMPORTANT

**Be sure to conform to the restrictions and precautions stated below when towing a light weight object using the bracket. The frame and/or the bracket may be damaged otherwise.**

- The allowable pulling capacity is indicated below.

Model	Maximum Drawbar Pull
ZX17U-6,19U-6	4900N (500kgf)
ZX26U-6	7800N (800kgf)

- Be sure to use a shackle.
- Keep the wire rope (1) horizontal, straight, and parallel to the tracks.
- Travel in the low speed mode.

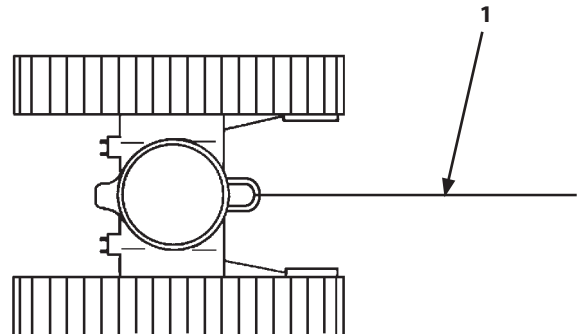

M1MS-04-004-1 ja

# OPERATING THE MACHINE

## Lowering the Boom in Emergencies and if the Engine Stops

### WARNING

- Never allow anyone under the boom during work.
- Hydraulic oil becomes hot and is under pressure during operation. Severe burns may result if skin comes in contact with escaping hydraulic oil just after operation. Wait for the oil to cool before starting any maintenance work. Loosen oil fill port cap (1) and bleed off air in the tank.

In case the engine suddenly stops and the engine cannot be restarted, lower the boom by following the procedure below.

1. Loosen the cover on top of the hydraulic oil tank, then loosen the oil fill port cap (1) inside and bleed off air in the tank.

### NOTE

*Top cover (5) on the ZX17U-6, 19U-6 cannot be removed until cover (4) on the right side of the hydraulic oil tank is removed.*

2. Remove bolts (2) on the front and left side of cover (3) and remove the cover.
3. Lower the boom according to the procedure on the next page.

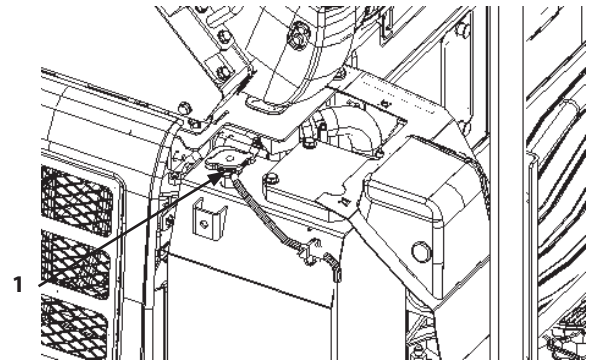

ZX17U-6,19U-6

MABA-05-007-1 ja

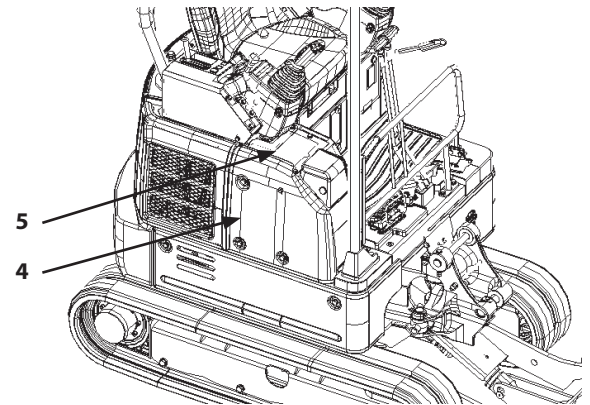

ZX17U-6,19U-6

MABA-05-008-1 ja

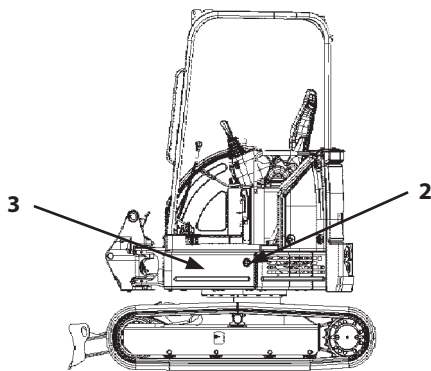

MABA-05-010-1 ja

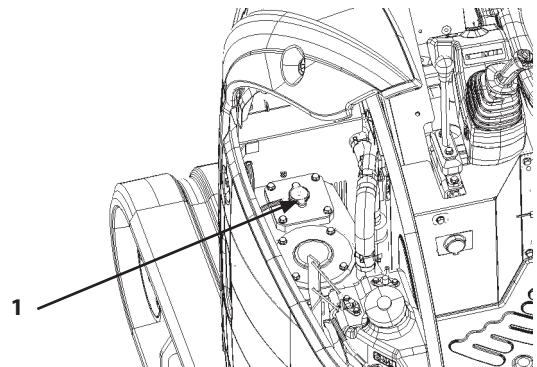

ZX26U-6

MABA-05-009-1 ja



## OPERATING THE MACHINE

ZX17U-6,19U-6

### WARNING

If boom spool (1) is removed quickly, the boom may drop suddenly. In addition, hydraulic oil may spurt out from the control valve. When removing boom spool (1), do so gradually.

1. Remove hex socket head bolt (3) and then remove boom spool (1) to lower the boom. When the body of boom spool (2) is removed, oil will leak from the control valve, so have an oil pan ready.
2. Check and make sure the boom has come down sufficiently and then install the body of boom spool (2) and tighten hex socket head bolt (3).

Tightening Torque: 6 to 7 N·m  
(0.6 to 0.7 kgf·m)

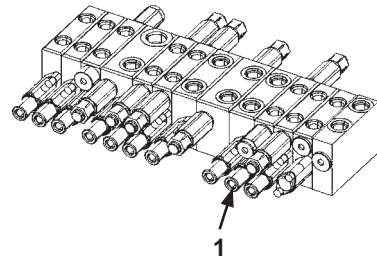

MABA-05-012-1 ja

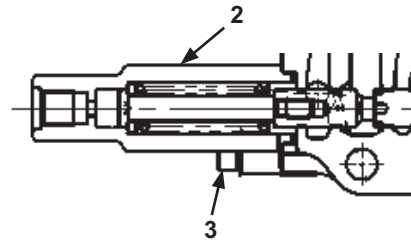

MABA-05-013-1 ja

## OPERATING THE MACHINE

### ZX26U-6

When there is no load on the front end:

#### **WARNING**

If overload relief valve (1) is loosened quickly, the boom may drop suddenly, so loosen it slowly. Also, do not loosen it more than 3/4 of a turn as hydraulic oil may spurt out if loosened any further.

1. Watch the movement of the boom and gradually loosen the body of overload relief valve (2).
2. Check and make sure the boom has come down enough and then tighten overload relief valve (2).

Tightening Torque: 60 to 70 N·m  
(6 to 7 kgf·m)

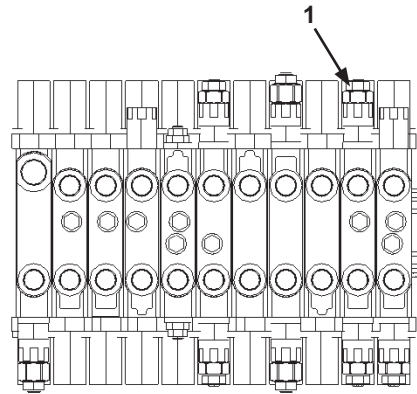

MABA-05-011-1 ja

If there is a load on the front end:

1. Make alignment marks on the locknut (4), adjustment screw (3) and body (2) of overload relief valve (1) on the boom raising side (cylinder bottom side).

#### **WARNING**

If adjustment screw (3) is loosened quickly, the boom may drop suddenly, so loosen it slowly.

2. Loosen locknut (4) and watch the movement of the boom while gradually loosening adjustment screw (3).
3. Check and make sure the boom has come down and then tighten adjustment screw (3) so its alignment mark matches body (2), then tighten locknut (4).

Tightening Torque: 28 to 32 N·m  
(2.8 to 3.2 kgf·m)

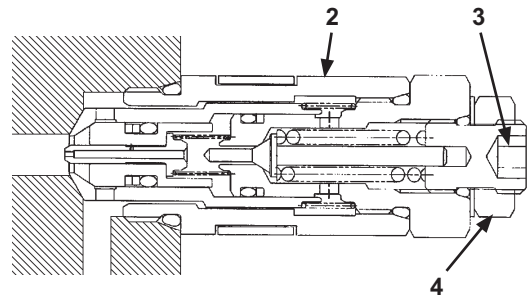

MABK-05-001-1 ja

## OPERATING THE MACHINE

---

### Precautions for After Operations

- After finishing the day's work, drive the machine to firm, level ground where no possibility of falling stones, ground collapse, or floods are present. Park the machine according to the parking procedures. (Refer to the section Parking in chapter 4, Driving the Machine.)
- Fully refill the fuel tank.
- Clean the machine.



M1M7-05-024 ja

## OPERATING THE MACHINE

---

---

**MEMO**

# TRANSPORTING

---

## Transporting by Road

- When transporting the machine with a truck, check the width, height, length and weight with the machine loaded. Note that transporting weight and dimensions may vary depending on the type of shoe or front attachments installed. Refer to the weights ( ) shown in the Standard Specifications section of Chapter 12 Specifications and take care not to overload it.
- Investigate conditions on the route to be traveled in advance, such as dimensional limits, weight limits, and traffic regulations.

In some cases it may be necessary to disassemble the machine to bring it within local regulation for dimensional or weight limits.

When transporting the machine, contact your authorized dealer.

## Loading/Unloading on a Truck

Always load and unload the machine on a firm, level surface.

### **WARNING**

- **Be sure to use a loading dock or a ramp for loading/unloading. Never use the front attachment functions when loading or unloading the machine.**
- **If the front is operated while traveling on a slope, the body may wander. Do not operate the front when traveling on a slope.**

## Ramp/Loading Dock

1. Before loading, thoroughly clean the ramps, loading dock and bed of the truck. Dirty ramps, loading docks, and flatbeds with oil, mud, or ice on them are slippery and dangerous.
2. Block the wheels of the truck to keep it from moving.
3. Ramps must be sufficient in width, length, and strength. Be sure that the incline of the ramp is less than 15 degrees.
4. Loading docks must be sufficient in width and strength to support the machine and have an incline of less than 15 degrees.
5. Take care not to hit the blade when loading and unloading onto a truck.

## TRANSPORTING

### Loading

#### WARNING

- **Always drive the machine slowly. Before descending a slope, always ensure that engine control lever (1) is in the slow idle position, and then reduce the engine speed. Turn the travel mode switch (2) to slow speed for ZX26U-6.**
- **Never steer while driving up or down a ramp as it is extremely dangerous and may cause the machine to turnover. NEVER attempt to change directions while on the ramp. If repositioning is necessary, first move back to the ground or flatbed, modify traveling direction, and begin to drive again.**
- **The top end of the ramp where it meets the flatbed has a sudden bump. Take care when traveling over it as it may unbalance the machine.**
- **Extreme care must be taken when swinging the upper structure when the machine is on the truck flatbed. If a front attachment is fitted, swing slowly with the arm fully roll-in underneath the boom, being careful not to unbalance the machine.**

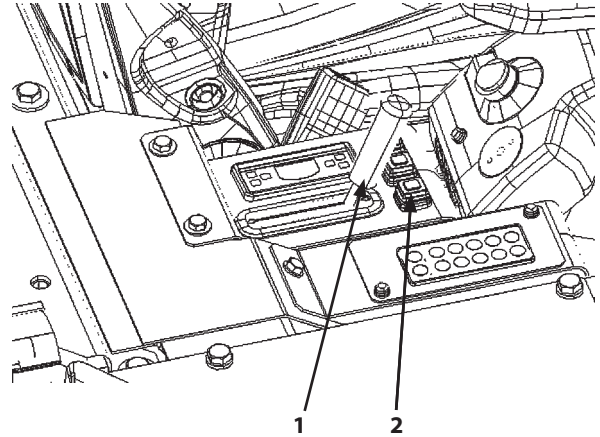

MABA-04-003-3 ja

## TRANSPORTING

1. Load the machine so that the centerline of the machine aligns with the centerline of the truck.
2. Drive the machine onto the ramp slowly.
3. Position the bucket on a flat surface of the truck. Keep the angle between boom and arm 90 to 110 °.
4. At the boundary between the ramp and the truck and before the machine tilts forward onto the truck, lower the bucket onto the bed of the truck.
5. Proceed to the point in the diagram at right. Then, with the arm rolled inwards, slowly swing the upper structure around 180 °.
6. Move backward to the designated position and stop.
7. Rest the front attachment on supports such as wooden blocks. Lower the blade.
8. Stop the engine. Remove the key from the key switch.
9. Pull the pilot control shut-off lever to the LOCK position.
10. Cover openings to the machine so rain and water do not get inside.

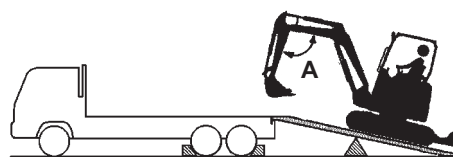

A: 90 to 110°

MADB-06-001-1 ja

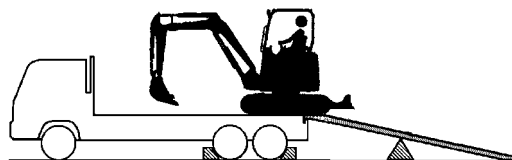

MABA-06-003 ja

### **WARNING**

**In cold weather, be sure to warm up the machine before loading or unloading it.**

# TRANSPORTING

## Fastening the Machine for Transport

ZX17U-6, 19U-6

### WARNING

- Fasten the machine frame to the deck securely with chains and cables.
- Use bracket (1) for towing light objects to secure the machine to the frame of the truck, taking care that cables and shoes do not interfere with each other.

While traveling, loads may shake around, move forward or backward or to the sides.

1. Place cog stoppers or blocks in front of and behind the tracks to help secure the machine.
2. Fasten the machine and front attachment to the trailer securely with appropriate strength of chains or cables. Securely attach wire ropes on the travel motor side to bracket (1) for towing light objects and to the truck bed as shown below for transport. Securely attach wire ropes on the front idler side to the tie-down brackets (2) on the blade and to the truck bed for transport.

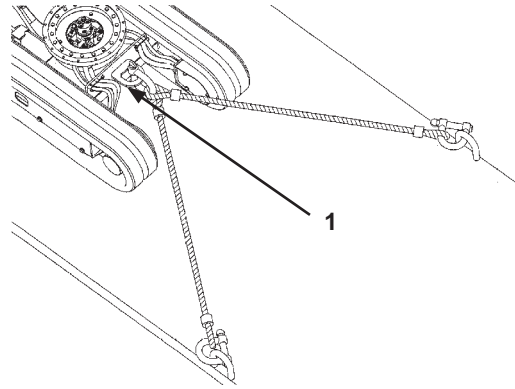

M1MS-06-003-2 ja

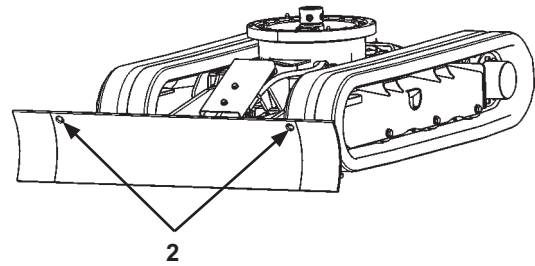

MABA-06-002-2 ja

## Transporting Rubber Crawler-Equipped Machines

Do not hook rope wire directly to the rubber crawlers when securing to the truck bed for transport. When attaching wire ropes and securing them to the truck bed, place protective materials on the left and right sides of the side frame, as shown below.

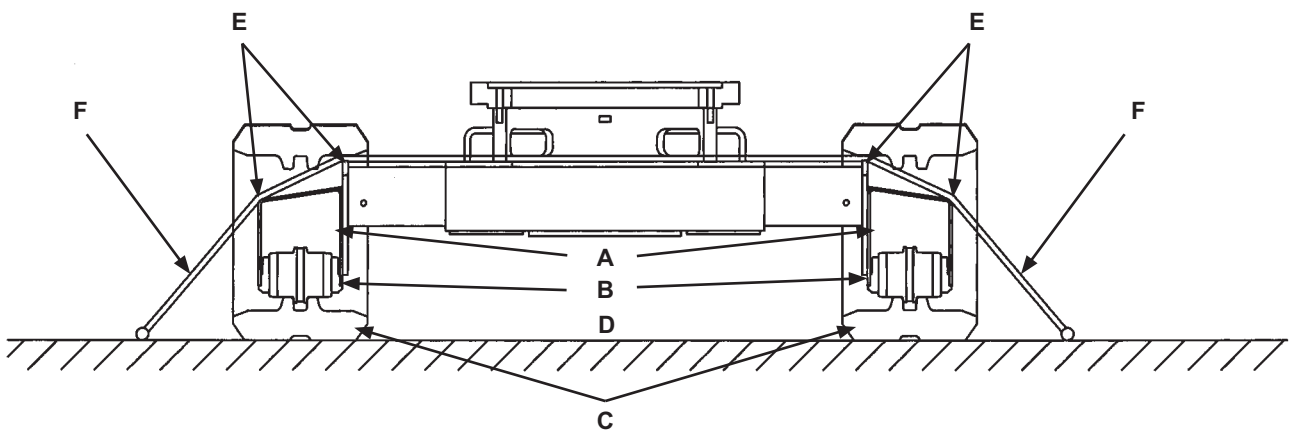

M1MS-06-001-2 ja

- |                 |                   |                   |
|-----------------|-------------------|-------------------|
| A: Side Frame   | C: Rubber Crawler | E: Soft Protector |
| B: Lower Roller | D: Truck Bed      | F: Wire Rope      |



## TRANSPORTING

---

ZX26U-6

### WARNING

- **Fasten the machine frame to the deck securely with chains and cables.**
- **Use brackets to secure the machine to the frame of the truck, taking care that cables and shoes do not interfere with each other.**

While traveling, loads may shake around, move forward or backward or to the sides.

1. Place cog stoppers or blocks in front of and behind the tracks to help secure the machine.
2. Fasten the machine and front attachment to the trailer securely with appropriate strength of chains or cables.

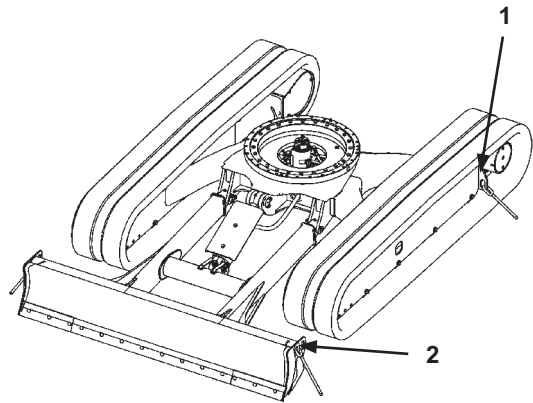

MADB-06-003-2 ja

### **Transporting Rubber Crawler-Equipped Machines**

Do not hook rope wire directly to the rubber crawlers when securing to the truck bed for transport. Securely attach wire ropes on the travel motor side to tie-down brackets (1) and to the truck bed as shown below for transport.

Securely attach wire ropes on the front idler side to tie-down brackets (2) on the left and right of the blade and to the truck bed as shown below for transport.

## TRANSPORTING

### Unloading

#### WARNING

- Always drive the machine slowly. Before descending a slope, always ensure that engine control lever (1) is in the slow idle position, and then reduce the engine speed. Turn the travel mode switch (2) to slow speed for ZX26U-6.
- Never steer while driving up or down a ramp as it is extremely dangerous and may cause the machine to turnover. NEVER attempt to change directions while on the ramp. If repositioning is necessary, first move back to the ground or flatbed, modify traveling direction, and begin to drive again.
- The top end of the ramp where it meets the flatbed has a sudden bump. Take care when traveling over it as it may unbalance the machine.

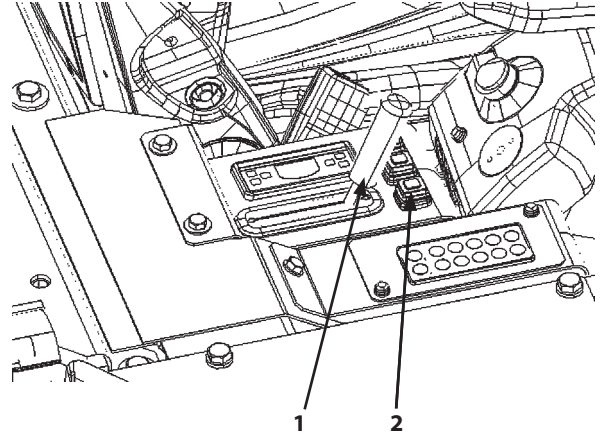

MABA-04-003-3 ja

#### IMPORTANT

Make sure that the angle of the boom and the arm is kept at between 90 to 110 ° when unloading the unit. Damage to the unit is possible if the arm is kept in a suspended state during unloading.

1. Travel extremely slowly with the bucket on the ground and the angle of the arm and the boom kept at between 90 to 110 ° when moving from the edge of the truck onto the ramp.

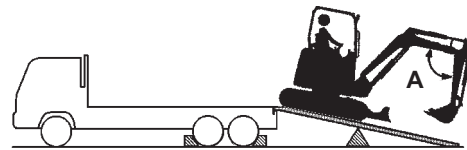

A: 90 to 110°

MADB-06-004-1 ja

#### IMPORTANT

When driving the machine over the ramp, do not allow the machine to hit the ground too hard with the arm. Possible damage to the hydraulic cylinders may result.

2. The bucket must be on the ground before the machine begins to tip forward.
3. As the machine moves forward, raise the boom and extend the arm until the machine is completely off the ramp.



MADB-06-005 ja

## TRANSPORTING

---

### Lifting the Machine

#### WARNING

- Use lifting cables and other lifting equipment that are sufficiently strong and free from any damage and/or other defects.
- Consult your authorized dealer for correct lifting procedures, and the size and types of lifting cable and tools.
- Pull the pilot control shut-off lever to the LOCK position so that the machine does not accidentally move while being lifted.
- Incorrect lifting procedure and/or incorrect wire rope attachment will cause the machine to move (shift) while being lifted, resulting in machine damage and/or personal injury.
- Do not lift the machine quickly. Excessive load will be applied to the lifting wire ropes and/or lifting tools, possibly causing them to break.
- Do not allow anyone close to, or underneath the lifted machine.
- The indicated center of gravity is for a machine with standard specifications. The center of gravity will vary depending on the kinds of attachments and/or optional equipment installed and their positioning. Take care not to unbalance the machine while lifting.
- Set the position of the blade while the engine is running. If set when the engine is stopped, the blade becomes unstable during lifting.

## TRANSPORTING

1. Position so the blade is behind the machine (counterweight side).
2. Lift the blade and set it at its stroke end.
3. As shown in the diagram at right, use the control lever to extend the bucket, arm and boom cylinders to their stroke ends.
4. Do not swing the boom and lock the swing pedal.
5. Pull the pilot control shut-off lever to the LOCK position (lever lifted).
6. Stop the engine. Remove the key from the key switch.
7. Position the crane appropriately.
8. Attach shackles to the hooks on the boom and blade and hook wire ropes to them securely.
9. Pay close attention to its balance and hoist slowly to avoid any shock to the machine.

ZX17U-6:3100mm  
ZX19U-6:3100mm  
ZX26U-6:2990mm

ZX17U-6:4710mm  
ZX19U-6:4710mm  
ZX26U-6:4990mm

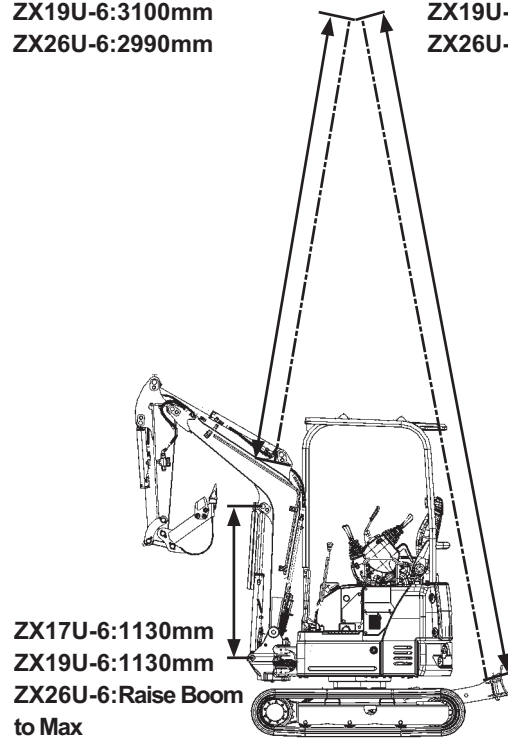

Posture before Lifting

MABA-06-001-2 en\_GB

# MAINTENANCE

---

## Correct Maintenance and Inspection Procedures

Learn how to service your machine correctly. Follow the correct maintenance and inspection procedures shown in this manual.

Inspect machine daily before starting.

- Check controls and instruments.
- Check coolant, fuel and oil levels
- Check for leaks, kinked, frayed or damaged hoses and lines.
- Walk around machine checking general appearance, noise, heat, etc.
- Check for loose or missing parts.

If there is any problem with your machine, repair it before operating or contact your authorized dealer.



SA-005 ja

## IMPORTANT

- **Use only specified fuel, lubricants and coolant.**
- **Be sure to use only genuine Hitachi parts. Use of anything other than genuine Hitachi products may result in serious injury or death and/or machine breakdown.**
- **Failure to use recommended fuel, lubricants, and genuine Hitachi parts will invalidate the Hitachi product warranty.**
- **Never adjust the engine governor or hydraulic system relief valves.**
- **Protect electrical parts from water and steam.**
- **Never disassemble electrical components such as the main controller, sensors, etc.**
- **Never adjust parts of the engine fuel system or hydraulic equipment.**
- **Using poor quality fuel, drainage agent, fuel additives, gasoline, kerosene or alcohol refueled or mixed with specified fuel may deteriorate performance of fuel filters and cause sliding problems at lubricated contacts in the injector. It also negatively impacts the engine and leads to malfunctions.**
- **Use Hitachi genuine high performance filters.**

## Check the Hour Meter Regularly

Refer to the Maintenance Guide (7-15) for information about lubricants, checks and adjustment intervals. Maintenance guide tables (7-3, 7-4, 7-5) are affixed under the seat as well.

Inspection and maintenance intervals shown in this manual are those for machines operated under normal conditions. If a machine is operated under more severe conditions, shorten the intervals.

# MAINTENANCE

## Name of Components

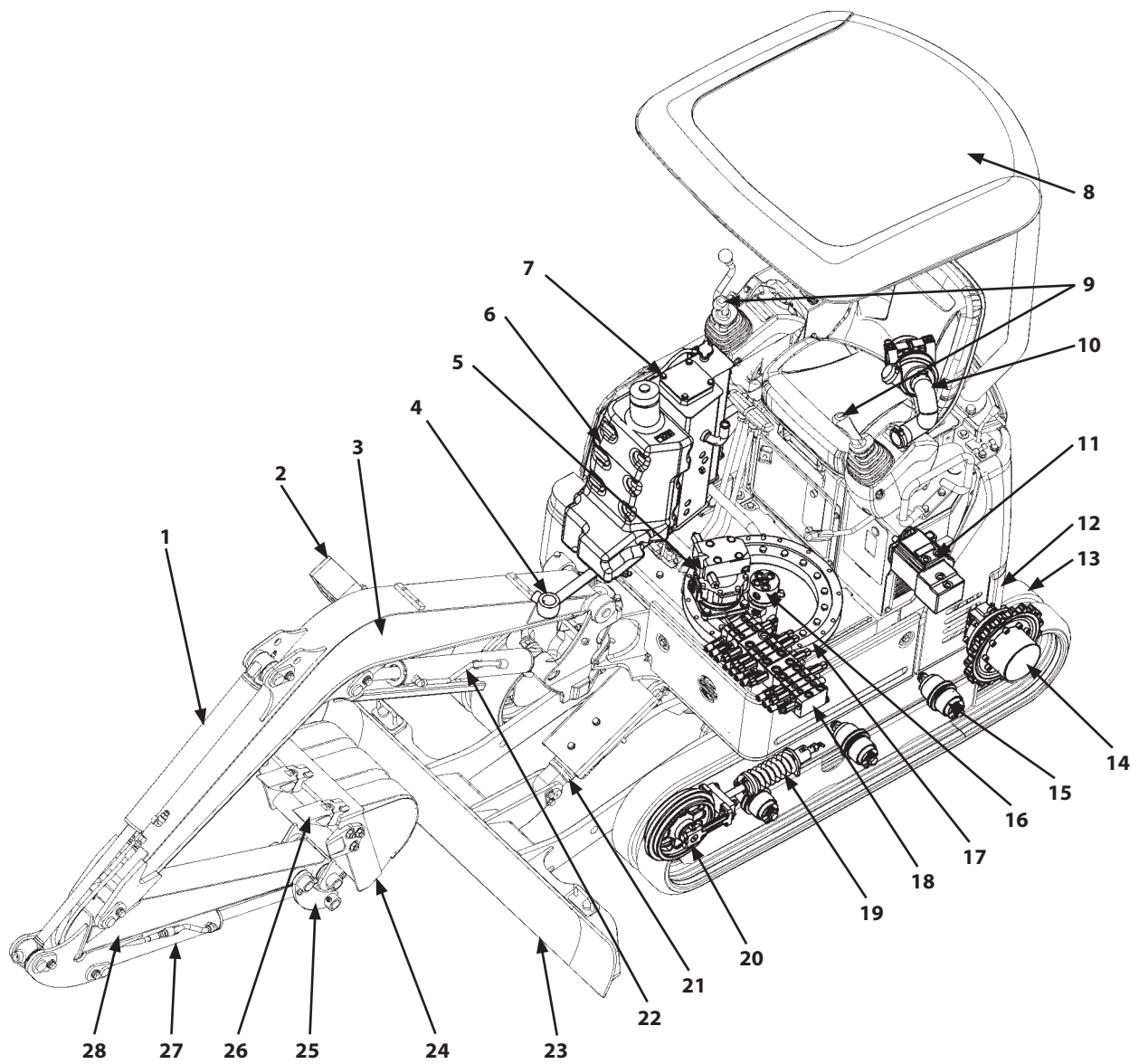

MABA-07-001-1 ja

- |                         |                   |                    |                     |
|-------------------------|-------------------|--------------------|---------------------|
| 1- Arm Cylinder         | 8- Canopy         | 15- Lower Roller   | 22- Boom Cylinder   |
| 2- Work Light           | 9- Control Lever  | 16- Center Joint   | 23- Blade           |
| 3- Boom                 | 10- Air Cleaner   | 17- Swing Bearing  | 24- Bucket          |
| 4- Boom Swing Cylinder  | 11- Pump          | 18- Control Valve  | 25- Link            |
| 5- Swing Reduction Gear | 12- Counterweight | 19- Track Adjuster | 26- Tooth           |
| 6- Fuel Tank            | 13- Track Shoe    | 20- Front Idler    | 27- Bucket Cylinder |
| 7- Hydraulic Oil Tank   | 14- Travel Device | 21- Blade Cylinder | 28- Arm             |









## MAINTENANCE

### Maintenance Guide Table

The maintenance guide table is affixed under the seat. Lubricate and/or service the parts at the intervals as instructed in the table so that all necessary maintenance is performed regularly.

- Symbol Marks

The following marks are used in the maintenance guide table.

	Grease (Front Joint Pin, Swing Bearing, Swing Gear)		Hydraulic Oil Filters (Pilot Filter, Hydraulic Oil Tank Filter, Suction Filter)
	Gear Oil (Travel Reduction Device)		Air Cleaner Element
	Engine Oil		Coolant (Long-Life Coolant)
	Engine Oil Filter		Fuel Filter
	Hydraulic Oil		

# MAINTENANCE

**Maintenance Guide Table**  
**ZX17U-6, 19U-6**

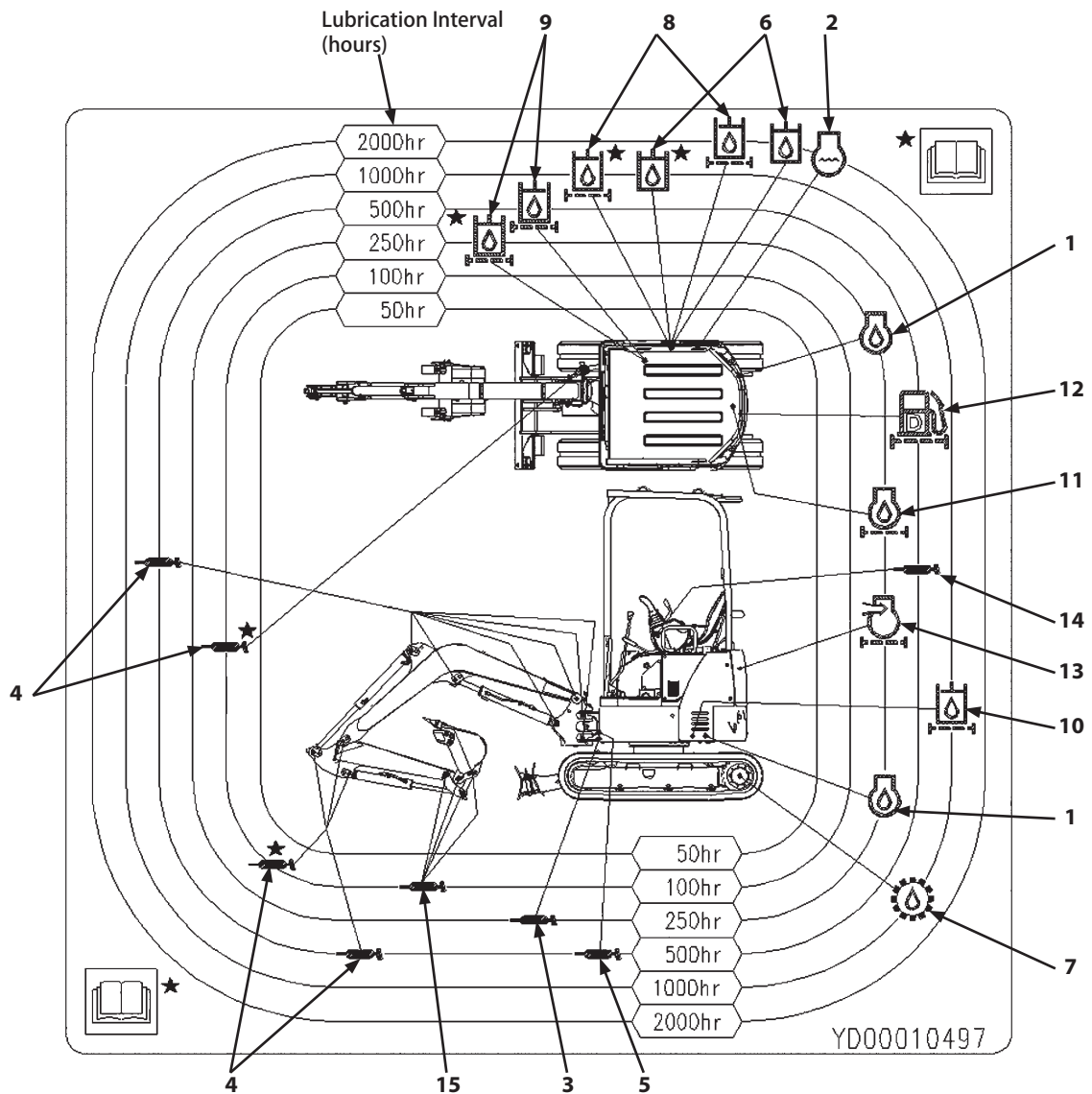

MABC-07-007-2 en\_GB

Item	Page	Item	Page
1 Engine Oil	7-31	9 Hydraulic Oil Filter (Full Flow)	7-47
2 Coolant (Long-Life Coolant)	7-67	10 Hydraulic Oil Filter (Pilot)	7-50
3 Grease (Swing Bearing)	7-27	11 Engine Oil Filter	7-31
4 Grease (Every 100 hours during first time operation up to 500 hours)	7-24	12 Fuel Filter	7-63
5 Grease (Swing Internal Gear)	7-28	13 Air Cleaner Element	7-65
6 Hydraulic Oil	7-41	14 Grease (Control Lever)	7-29
7 Gear Oil (Travel Reduction Gear)	7-34	15 Grease (Bucket)	7-24
8 Hydraulic Oil Filter (Suction)	7-41		



# MAINTENANCE

**Maintenance Guide Table**  
**ZX26U-6**

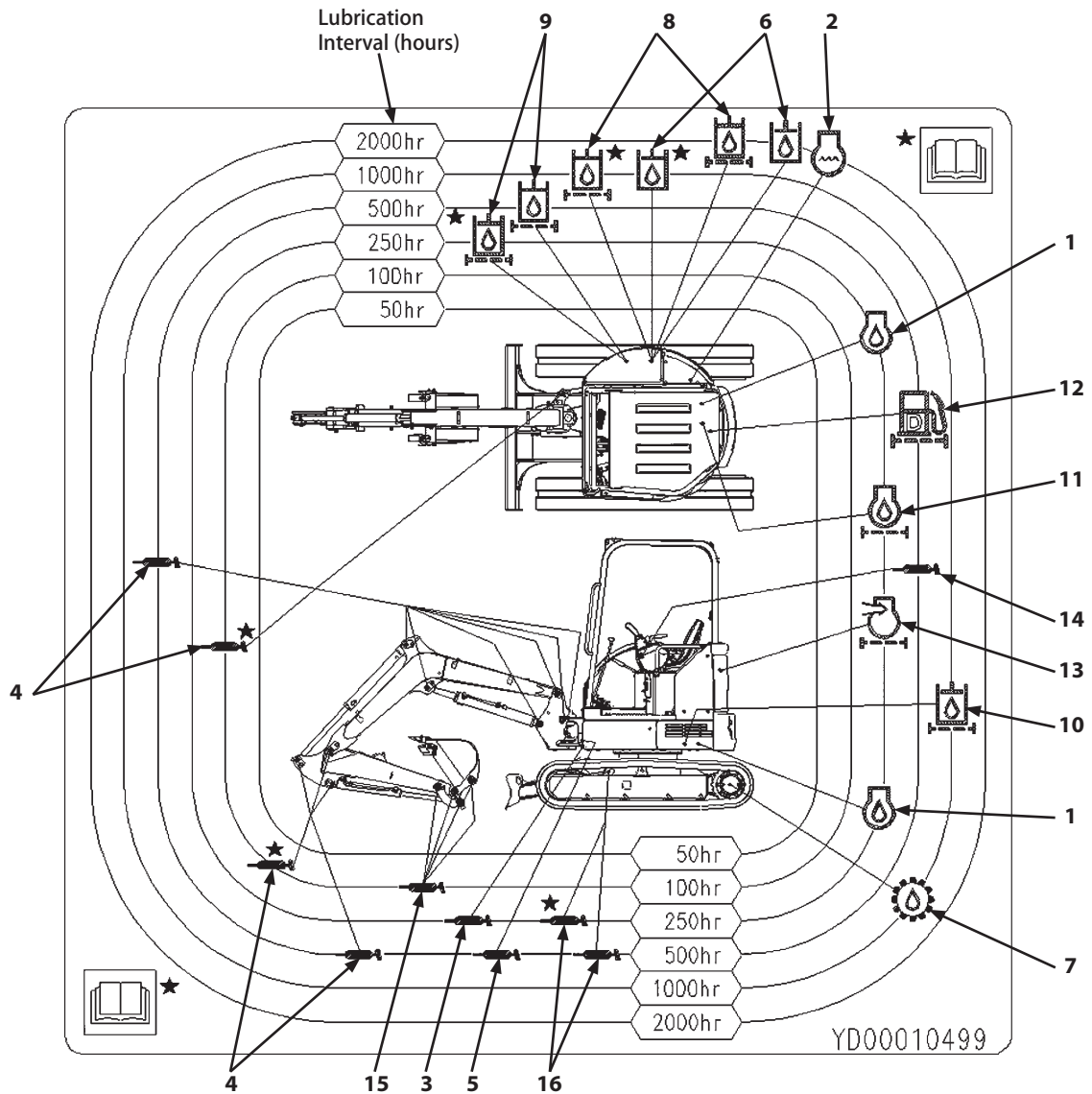

MABC-07-008-3 en\_GB

Item	Page	Item	Page
1 Engine Oil	7-31	9 Hydraulic Oil Filter (Full Flow)	7-47
2 Coolant (Long-Life Coolant)	7-67	10 Hydraulic Oil Filter (Pilot)	7-50
3 Grease (Swing Bearing)	7-27	11 Engine Oil Filter	7-31
4 Grease (Every 100 hours during first time operation up to 500 hours)	7-24	12 Fuel Filter	7-63
5 Grease (Swing Internal Gear)	7-28	13 Air Cleaner Element	7-65
6 Hydraulic Oil	7-41	14 Grease (Control Lever)	7-29
7 Gear Oil (Travel Reduction Gear)	7-34	15 Grease (Bucket)	7-24
8 Hydraulic Oil Filter (Suction)	7-41	16 Grease (Blade)	7-26

# MAINTENANCE

## Preparation for Inspection and Maintenance

Except in special cases, park the machine as indicated below before servicing the machine.

1. Park the machine on a firm, level surface.
2. Lower the bucket and blade to the ground.
3. Put the engine control lever in the slow idle position and run the engine for 5 minutes to cool it.
4. Turn the key switch OFF to stop the engine. Remove the key.
5. Be sure to place pilot control shut-off lever (1) in the LOCK position.
6. Put a sign saying "Being Serviced" on the door or in an easy-to-notice place before starting work.

### **WARNING**

**To prevent accidents, never attempt to perform maintenance on the machine when the engine is running. If maintenance work with the engine running is unavoidable, strictly comply with the following items.**

- **One person should take the operator's seat and be ready to stop the engine at any time, while communicating with other workers.**
- **When working around moving parts, pay special attention to ensure that hands, feet, and clothing do not become entangled.**
- **If parts or tools are dropped or inserted into the fan or the belt, they may fly off or be cut off. Do not drop or insert parts and tools into moving parts.**
- **Move pilot control shut-off lever (1) to the LOCK position so work equipment does not move.**
- **Never touch the control levers and pedals. If operating the control levers or pedals is unavoidable, signal co-workers to evacuate to a safe place.**



M1M7-05-024 ja

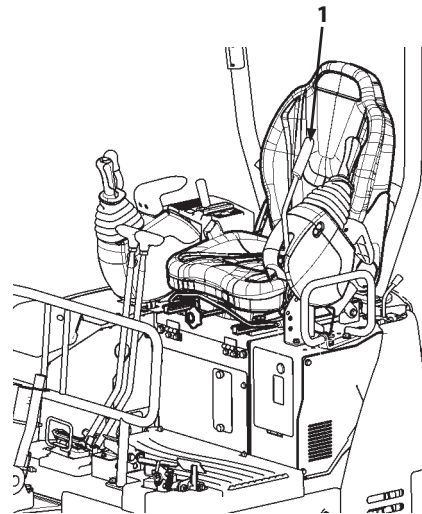

MABA-01-002-2 ja

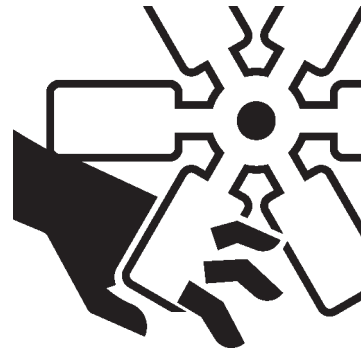

SA-2294 ja

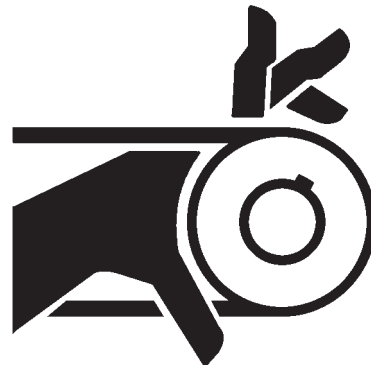

SA-026 ja

# MAINTENANCE

## Access Covers

### Opening and Closing the Engine Cover ZX17U-6, 19U-6

#### WARNING

- Do not keep the access covers open when the machine is parked on a slope, or while the wind is blowing hard. The hood or access covers may close accidentally, possibly resulting in personal injury.
- When opening or closing the access covers, take extra care not to catch fingers between the base machine and the hood or access covers.

Pull up latch (2) to open latch (1). Cover (1) is raised by mechanism (3).

Be sure to fully raise the cover after confirming that stopper (4) provided on the left link is placed in LOCK position (5). This lock cover (1) in place.

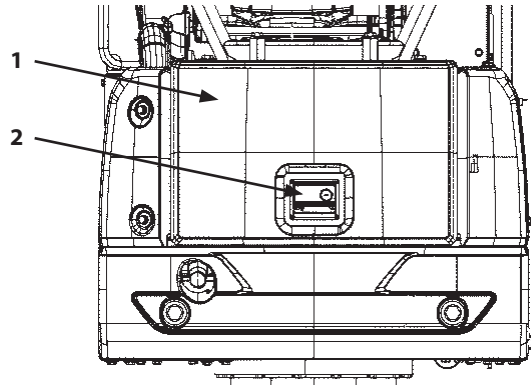

MABK-07-010-1 ja

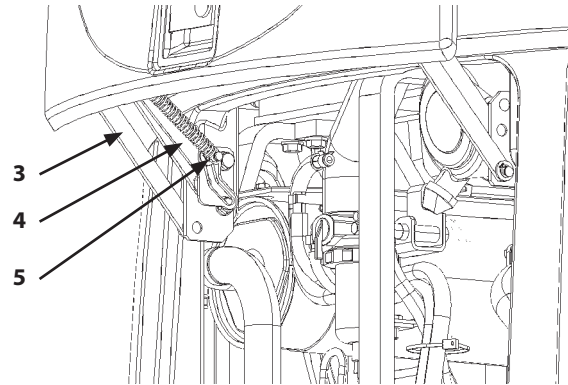

M1M7-07-010-1 ja

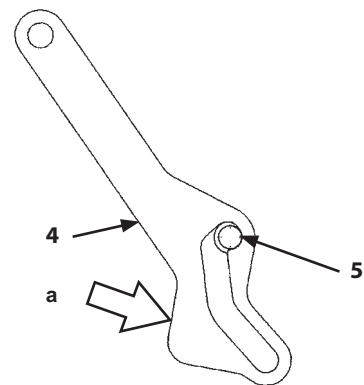

LOCK position

M1M7-07-069-2 ja

## MAINTENANCE

Before closing cover (1), make sure radiator front cover (6) is locked with lock (7).

When closing cover (1), hold it up and push stopper (4) into position (a) indicated by the arrow. This unlocks it. With stopper (4) pushed in place, lower cover (1) and when it is lowered by about one fourth, release stopper (4).

Then, lower cover (1) to completely close it.

Be sure to remove your hand which is pushing stopper (4) so it is outside cover (1). Failure to do so may leave your hand caught in the cover (1).

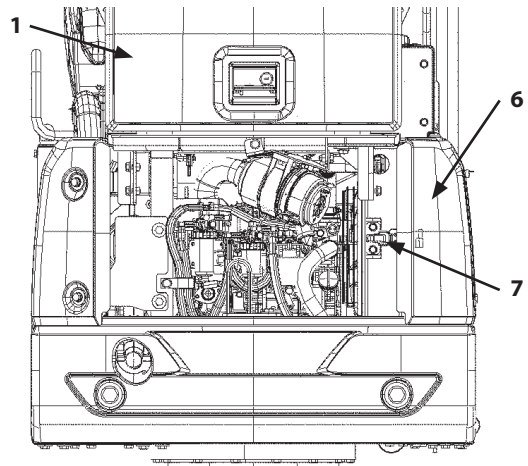

MABK-07-011-1 ja

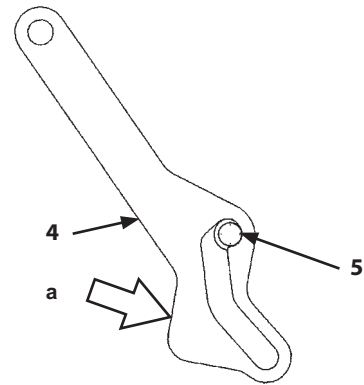

LOCK position

M1M7-07-069-2 ja

# MAINTENANCE

## Opening and Closing the Engine Cover

ZX26U-6

### WARNING

- Do not keep the access covers open when the machine is parked on a slope, or while the wind is blowing hard. The hood or access covers may close accidentally, possibly resulting in personal injury.
- When opening or closing the access covers, take extra care not to catch fingers between the base machine and the hood or access covers.

Pull up latch (2) to open latch (1). Cover (1) is raised by mechanism (3).

Be sure to fully raise the cover after confirming that stopper (4) provided on the left link is placed in LOCK position (5). This lock cover (1) in place.

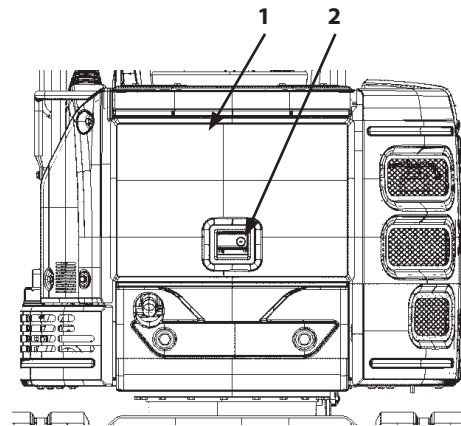

MABA-07-004-1 ja

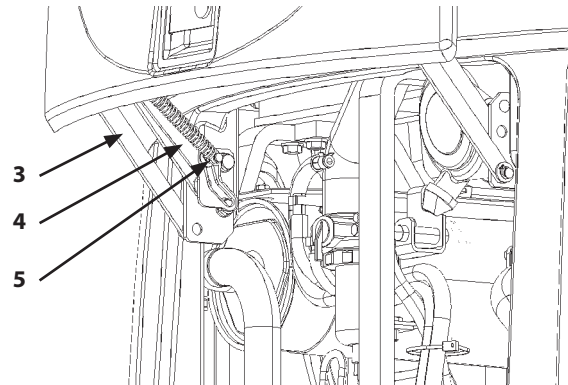

M1M7-07-010-1 ja

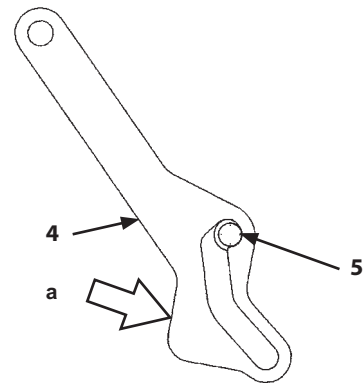

LOCK position

M1M7-07-069-2 ja

## MAINTENANCE

Before closing cover (1), make sure radiator front cover (6) is locked with lock (7).

When closing cover (1), hold cover (1) up and push stopper (4) into position (a) indicated by the arrow. This unlocks it.

With stopper (4) pushed in place, lower cover (1) and when it is lowered by about one fourth, release stopper (4).

Then, lower cover (1) to completely close it.

Be sure to remove the hand that is pushing stopper (4) at this time so it is outside cover (1).

Failure to do so may allow your hand to get caught in cover (1).

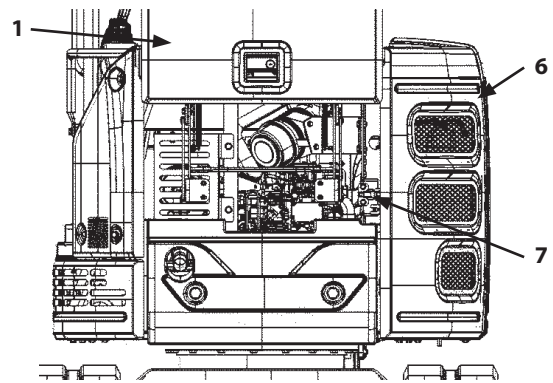

MABA-07-005-3 ja

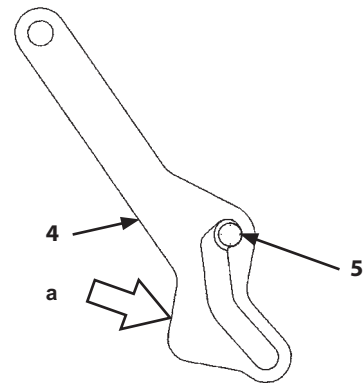

LOCK position

M1M7-07-069-2 ja

# MAINTENANCE

## Opening and Closing the Tank Cover

ZX17U-6,19U-6

### WARNING

- Do not keep the hood and access covers open when the machine is parked on a slope, or while the wind is blowing hard. The hood or access covers may close accidentally, possibly resulting in personal injury.
- When opening or closing the access covers, take extra care not to catch fingers between the base machine and the hood or access covers.

### Opening and Closing the Fuel Fill Port Cover

1. To open cover (1), insert the key into keyhole (2) and turn the key clockwise to unlock it. Open cover (1).
2. When closing cover (1), lower it and turn the key counterclockwise and make sure it locks.

### Opening and Closing the Hydraulic Oil Tank Cover

- When opening cover (3), remove the 2 bolts (4). Securely tighten bolts (4) when closing the cover.
- When opening cover (5), remove the 3 bolts (6). Securely tighten bolts (6) when closing the cover.

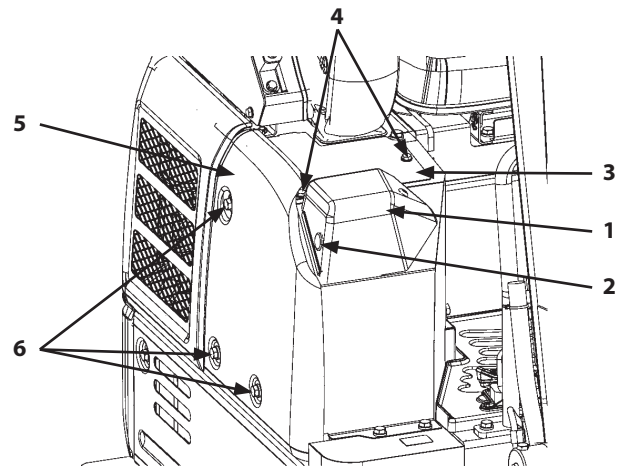

MABA-07-006-1 ja

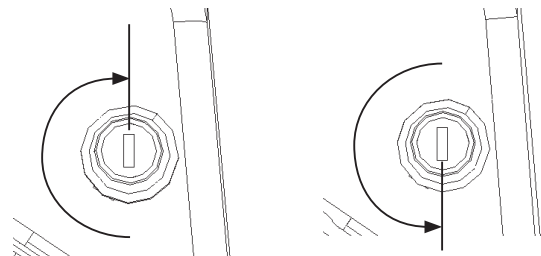

Unlocked Position

MABK-07-016-1 ja

Locked Position

MABK-07-015-1 ja

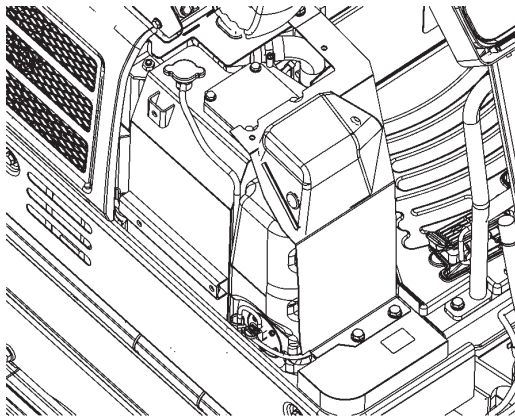

With Hydraulic Oil Tank Cover Open

MABA-07-055 ja

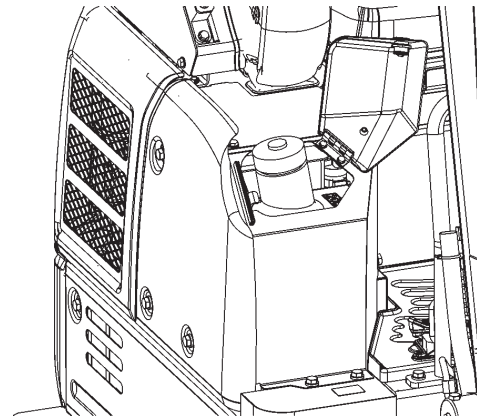

With Fuel Fill Port Cover Open

MABA-07-007 ja

# MAINTENANCE

## Opening and Closing the Tank Cover

ZX26U-6

### WARNING

- Do not keep the hood and access covers open when the machine is parked on a slope, or while the wind is blowing hard. The hood or access covers may close accidentally, possibly resulting in personal injury.
- When opening or closing the access covers, take extra care not to catch fingers between the base machine and the hood or access covers.

1. Press button (2) and raise cover (1) to open cover (1).
2. Raise cover (1) until stopper (3) fits into the lock position on bracket (4).
3. Confirm that stopper (3) is in the LOCK position before releasing your hands.

### CAUTION

When closing cover (1), make sure it is securely locked.

4. When closing cover (1), push stopper (3) while raising cover (1) by hand.
5. While pushing stopper (3), lower cover (1), when cover (1) is lowered by a 1/4 stroke, release stopper (3).

### NOTE

Button (2) can be locked by the key.

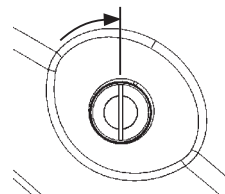
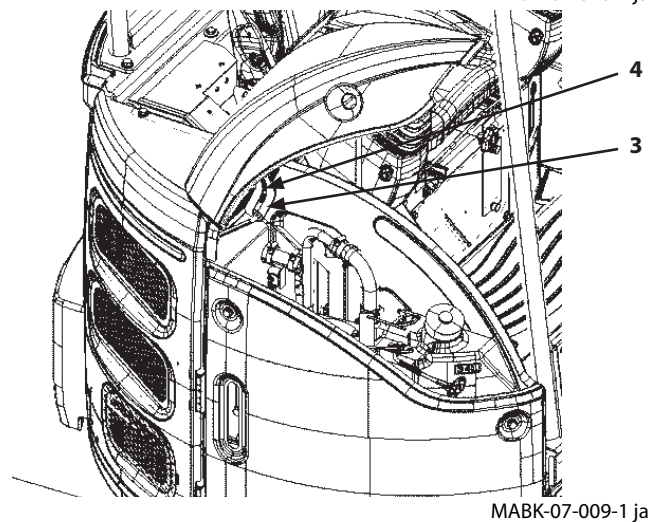
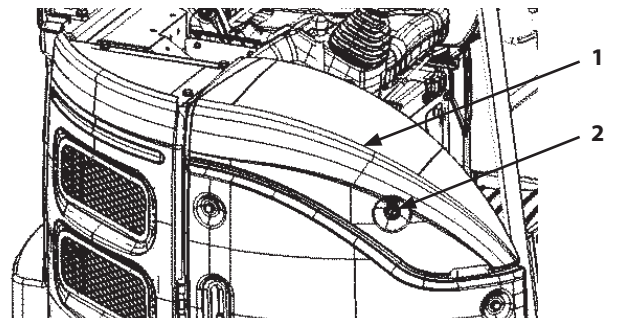

Cover Open/Close  
Button (2)  
(UNLOCK Position)

MAEP-07-001-1 ja

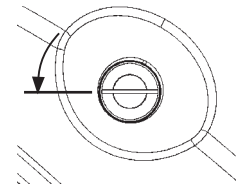

Cover Open/Close  
Button (2)  
(LOCK Position)

MAEP-07-002-1 ja



## MAINTENANCE

### Opening and Closing Radiator Front Cover

ZX17U-6, 19U-6

#### WARNING

- Do not keep the hood and access covers open when the machine is parked on a slope, or while the wind is blowing hard. The hood or access covers may close accidentally, possibly resulting in personal injury.
- When opening or closing the hood and access covers, take extra care not to catch fingers between the base machine and the hood or access covers.
- When opening the radiator front cover, first open engine cover (1), lift the bar and unlock lock (2).
- Secure the radiator front cover in place by inserting rod (3) into lock hole (4).
- When closing radiator front cover, lift up rod (3) and stow it in rod storage hook (5).

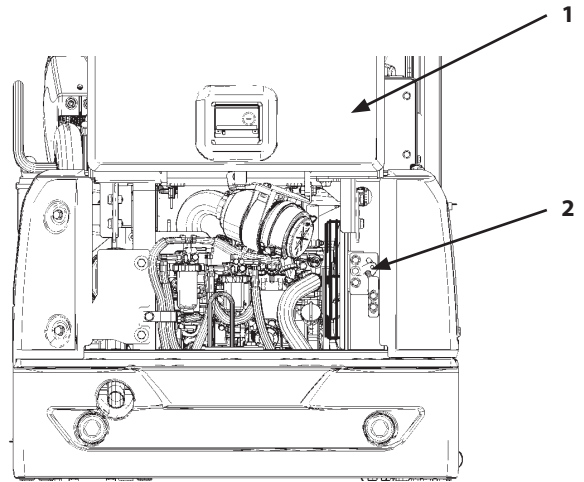

MABA-07-067-1 ja

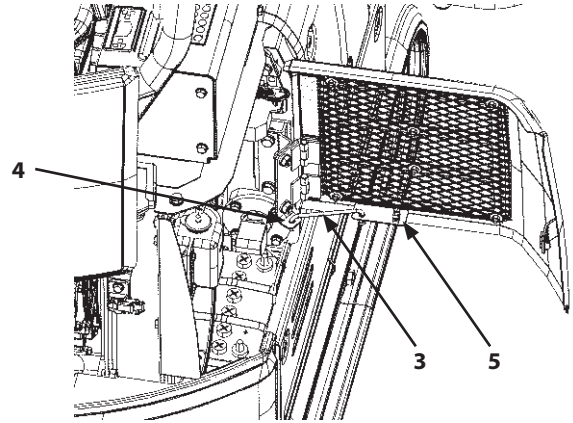

MABA-07-012-1 ja

## MAINTENANCE

### Opening and Closing Radiator Front Cover

ZX26U-6

#### WARNING

- Do not keep the hood and access covers open when the machine is parked on a slope, or while the wind is blowing hard. The hood or access covers may close accidentally, possibly resulting in personal injury.
- When opening or closing the hood and access covers, take extra care not to catch fingers between the base machine and the hood or access covers.
- When opening the radiator front cover, first open engine cover (1) and then unlock lock (2).
- Open the radiator front cover until rod (3) fits into the lock position in rail groove (4).
- Raise rod (3) to release lock before closing the radiator front cover.

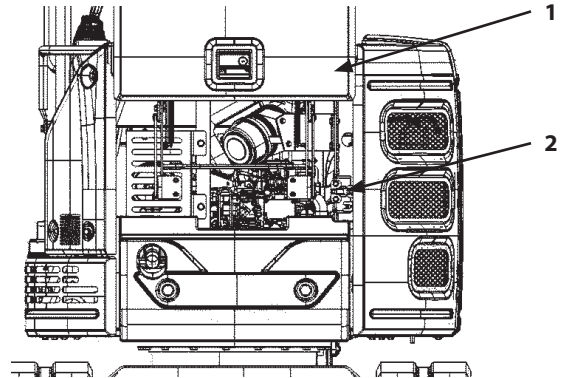

MABA-07-005-2 ja

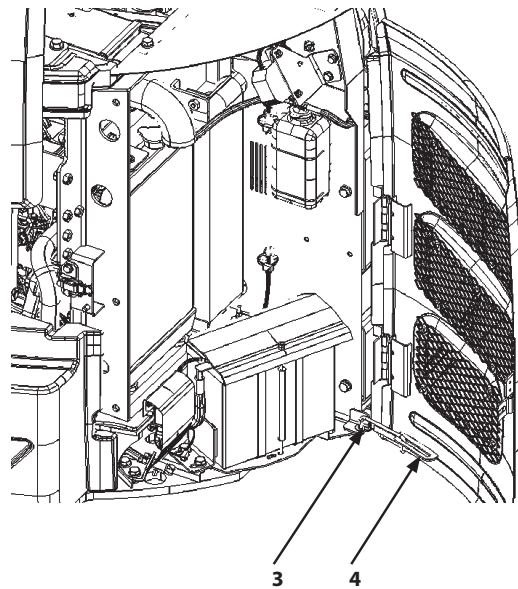

MABA-07-013-1 ja

# MAINTENANCE

## Maintenance Guide

### A. Greasing

Parts		Quantity	Interval (Hours)						Page	
			8	50	100	250	500	1000		2000
1. Front Joint Pins	Bucket and Link Pins	5	★	★★						7-24
	Swing Post and Others	10	★	★★	★★★				or every year	7-24
2. Blade Pins (ZX26U-6)		2				★★★★			or every year	7-26
3. Swing Bearing		1								7-27
4. Swing Internal Gear		1								7-28
5. Control Lever Universal Joint		2							or every year	7-29

- ★ : If excavations are performed in water, grease the pin after operation is complete.
- ★★ : When using a hydraulic breaker, grease every 50 hours.
- ★★★ : Grease all pins every 100 hours during the first 500 hours of operation first.
- ★★★★ : Maintenance required only during first time.

### IMPORTANT

**Grease front joint pins every day until break-in operation (50 hours) is complete.**

### B. Engine

Parts		Quantity	Interval (hours)						Page	
			8	50	100	250	500	1000		2000
1. Engine Oil	Check Oil Level	1								7-30
2. Engine Oil	Re-place	ZX17U-6,19U-6	2.8 L				★			7-31
		ZX26U-6	3.5 L							
3. Engine Oil Filter	Replace	1				★				7-31

- ★ : Oil life is shortened at high temperatures, so shorten the maintenance interval.

### C. Transmission

Parts		Quantity	Interval (hours)						Page	
			8	50	100	250	500	1000		2000
1. Travel Device	Check Oil Level		2							7-34
	Re-place	ZX17U-6, 19U-6	0.25 Lx2							7-34
		ZX26U-6	0.6 Lx2							7-34

## MAINTENANCE

### D. Hydraulic System

Parts	Qty.	Interval (hours)									Page	
		8	50	100	250	500	1000	1500	2000	3000		
1. Check Hydraulic Oil Level	1										7-39	
2. Drain Hydraulic Oil Tank Sump	1										7-40	
3. Change Hydraulic Oil	ZX17U-6, 19U-6	26 L								★	★	7-41
	ZX26U-6	39 L										
4. Cleaning the Suction Filter	1	Each time hydraulic oil is changed									7-41	
5. Replace Full-Flow Filter	Paper Filter	1				★★	★					7-47
	High Performance Filter (Optional)	1					★★	★				
6. Replace Pilot Oil Filter Element	1										7-50	
7. Check Hoses and Lines	For leaks, looseness	-										7-53
	cracks, bends, etc.	-										7-53

★ : The change interval depends on the brand of hydraulic oil used, kind of filter element and average attachment operating rate. Refer to the section (7-59), Changing Hydraulic Oil and Replacing Full-Flow Filter Element.

★★ : 1st time only

### E. Fuel System

Tank Capacity: 20 L (ZX17U-6, 19U-6)

32 L (ZX26U-6)

Parts	Qty.	Interval (hours)							Page
		8	50	100	250	500	1000	2000	
1. Check Fuel Level	1								7-59
2. Check Water Separator	1								7-60
3. Drain Fuel Tank Sump	1	As required							7-62
4. Replace Fuel Main Filter Element	1								7-63
5. Check Fuel Hoses	for leaks, cracks	-							7-64
	cracks, bend, etc.	-							7-64

## MAINTENANCE

### F. Air Cleaner

Parts		Qty.	Interval (hours)						Page		
			8	50	100	250	500	1000		2000	
1.	Air Cleaner Filter	Clean	1				★				7-65
		Replace	1	After cleaning 6 times or 1 year						7-65	

★ : Shorten the maintenance interval when the machine is operated in dusty areas.

### G. Cooling System

Parts		Qty.	Interval (hours)						Page	
			8	50	100	250	500	1000		2000
1.	Check Coolant Level	1								7-67
2.	Check and Adjust Fan Belt Tension	1		★★						7-68
3.	Change Coolant	ZX17U-6, 19U-6	2.7 L	Twice yearly * , spring and autumn						7-71
		ZX26U-6	3.1 L							
4.	Clean Radiator/Oil Cooler Core	Outside	1				★			7-73
		Inside	1	Replacing Coolant						

★ : Shorten the maintenance interval when the machine is operated in dusty areas.

★★ : 1st time only

\* : When genuine Hitachi Long-Life Coolant (LCC) is used, the change interval is once every two years (in autumn every other year) or every 2,000 hours, whichever comes first.

### IMPORTANT

- **Use soft water as a coolant. Do not use strong acid or alkaline water. Use a coolant with genuine Hitachi Long-Life Coolant (LLC) at a mixture of 30 to 50 %. If a coolant mixed with less than 30 % of Hitachi Long-Life Coolant (LLC) is used, the service life of the cooling parts may be shortened due to damage by freezing or corrosion of coolant system parts.**
- **If mineral-rich water is used for coolant, water stains or scale may build up inside the engine or radiator, causing overheating due to deterioration of coolant performance.**

## MAINTENANCE

### H. Electrical System

Parts		Qty.	Interval (hours)						Page
			8	50	100	250	500	1000	
1. Battery	Check Electrolyte Level	1	Monthly						7-77
	Check electrolyte specific gravity	1	Monthly						7-78
2. Replacement Of Fuses	Replace	-	As required						7-80

### I. Miscellaneous

Parts		Qty.	Interval (hours)								Page
			8	50	100	250	500	1000	1500	2000	
1. Check and Replace Bucket Teeth	-										7-81
2. Change Bucket	1	As required								7-83	
3. Adjust Track Sag (Rubber Crawler) and Check for Damage	2										7-84
4. Replace Rubber Crawler	2	As required								7-86	
5. Check and Replace Seat Belt	1		Every 3 years							7-88	
6. Clean Cab Floor	-	As required								7-88	
7. Check, Clean and Function Check of Injection Nozzle	-							*			7-89
8. Inspect and Adjust Valve Clearance	-						*				7-89
9. Check and Adjust Injection Timing	-							*			7-89
10. Measure Engine Compression Pressure	-	As required								7-89	
11. Check Starter and Alternator	-						*				7-89
12. Check Crankcase Breather	-							*			7-90
13. Check Radiator Cap	-								*		7-90
14. Tightening and Retightening Torque of Nuts and Bolts	-		★★		*						7-91

 **NOTE**

\*Contact your authorized dealer for maintenance. An instruction plate with the recommended grease and lubricants is affixed inside the tool box cover.

★★ : 1st time only

## MAINTENANCE

### Periodic Replacement of Parts

To ensure safe operation and long life, be sure to conduct periodic inspection and maintenance of the machine. In addition, the parts listed below, may pose serious safety/fire hazards if defective.

These parts may cause serious safety/fire hazards due to deterioration, wear, or fatigue being attributed to material aging or repeated operation. This may lead to a serious personal accident or safety/fire hazard. It is very difficult to gauge the extent of deterioration, fatigue, or weakening of the parts listed below simply by visual inspection alone.

For this reason, replace these parts at the intervals shown in the table below.

If replacement of such components is required, contact your authorized dealer.

Periodic Replacement of Parts		Replacement Interval	
ENGINE	Fuel Hose (Tank to Filter)	Every 2 years	
	Fuel Hose (Tank to Injection Pump)		
	Engine rubber vibration insulator	Every 5 years or 3000 hours whichever comes first	
	Pump Coupling		
Hydraulic System	Base Machine	Pump Suction Hose	Every 2 years or 4000 hours whichever comes first
		Pump Delivery Hose	
		Swing Hose	
		Auxiliary Hose	
		Oil Cooler Hose (C/V to Oil cooler)	
	Working Device	Boom cylinder line hose	
		Arm cylinder line hose	
		Bucket cylinder line hose	
Pilot Hose			
Seat Belt		Every 3 years	

 **NOTE**

*Be sure to replace seals, such as O-rings and gaskets, when replacing hoses.*

## MAINTENANCE

### Kind of Oils

#### Brand Name of Recommended Grease

Kind of Grease		Lithium Grease
Application		Front Attachment Joint Pins, Swing Bearing, Swing Internal Gear
Air Temp.		-20 to 40 °C (-4 to 104 °F)
Recommended Products		Hitachi Genuine Grease NLGI EP-2
Alternative Products	Specification	NLGI 2 EP

#### IMPORTANT

- **Hitachi Genuine Greases are specially designed and tested to provide optimum performance for the machine, hence we recommend to use Hitachi Genuine Greases.**
- **If you do not use Hitachi Genuine Greases, use grease conforming to EP-2. Otherwise, the machine may suffer damage.**
- **Do not use greases which do not meet the above specification or requirements. Use of unsuitable grease may lead to damage which is excluded from Hitachi Warranty Policy.**
- **For details, contact your nearest authorized dealer.**

#### Recommended Engine Oil

Kind of Oil		Engine Oil	
Application		Engine Crank Case	
Air Temp.		-20 to 30 °C (-4 to 86 °F)	-15 to 40 °C (5 to 104 °F)
Recommended Products		Hitachi Genuine Engine Oil DH-1 10W-30	Hitachi Genuine Engine Oil DH-1 15W-40
Alternative Products	Viscosity	10W-30	15W-40
	Specification	JASO DH-1	

#### IMPORTANT

- **Hitachi Genuine Engine Oils are specially designed and tested to provide optimum performance for the machine, hence we recommend to use Hitachi Genuine Engine Oils.**
- **If you do not use Hitachi Genuine Engine Oil, use engine oil conforming to JASO DH-1. Otherwise, engine and muffler filter may suffer damage, or performance of engine may deteriorate.**
- **Do not use oils which do not meet the above specification or requirements. Use of unsuitable oil may lead to engine damage which is excluded from Hitachi Warranty Policy.**
- **For details, contact your nearest authorized dealer.**



## MAINTENANCE

### Brand Name of Recommended Oil

Application		Travel Reduction Gear
Kind of Oil		Gear Oil
Air Temp.		-20 to 40 °C (-4 to 104 °F)
Recommended Products		Hitachi Gear Oil GL-4 90
Alternative Products	Specification	API GL-4

### IMPORTANT

- **Hitachi Genuine Gear Oil are specially designed and tested to provide optimum performance for the machine, hence we recommend to use Hitachi Genuine Gear Oil.**
- **If you do not use Hitachi Genuine Gear Oil , use gear oil or engine oil conforming to specifications described above. Otherwise, the machine may suffer damage.**
- **Do not use oils which do not meet the above specification or requirements. Use of unsuitable oil may lead to engine damage which is excluded from Hitachi Warranty Policy.**
- **For details, contact your nearest authorized dealer.**

### Brand Name of Recommended Hydraulic Oil

Kind of Lubricant	Hydraulic Oil	
Where to be applied	Hydraulic System	
Change Interval	2000 hours	1000 hours
Environmental Temp.	-20 to 40 °C (-4 to 104 °F)	
Recommended Products	Hitachi Genuine Hydraulic Oil 2000	Hitachi Genuine Hydraulic Oil Multi
Alternative Product		Product Conforming to JCMAS HK VG46W

### NOTE

*A different interval of oil change may be required for Alternative Products.  
For details, contact your nearest authorized dealer.*

### IMPORTANT

- **Hitachi Genuine Hydraulic Oils are specially designed and tested to provide optimum performance for the machine, hence we recommend to use Hitachi Genuine Hydraulic Oils.**
- **If you do not use Hitachi Genuine Hydraulic Oil, use hydraulic oil conforming to JCMAS HK VG46W. Otherwise, the machine may suffer damage. For the information of JCMAS HK VG46W, refer to JALOS website.**
- **Do not use oils which do not meet the above specification or requirements. Use of unsuitable grease may lead to damage which is excluded from Hitachi Warranty Policy.**

## MAINTENANCE

### Recommended Oil Viscosity

Where to be Applied	Kind of Oil	Air Temperature (degrees Celsius)								
		-30	-20	-10	0	10	20	30	40	
Engine Oil Pan	Engine Oil									Hitachi Genuine Engine Oil DH-1 10W30
										Hitachi Genuine Engine Oil DH-1 15W40
Travel Device	Gear Oil									Hitachi Gear Oil GL-4_90
Hydraulic System (Hydraulic Oil Tank)	Hydraulic Oil									Hitachi Genuine Hydraulic Oil 2000 Hitachi Genuine Hydraulic Oil Multi
Fuel Tank	Diesel Fuel									EN590 ClassA
										EN590 ClassB
										EN590 ClassC
										EN590 ClassD
										EN590 ClassE
										EN590 ClassF
Grease fitting	Lithium Grease									Hitachi Genuine Grease NLGI EP-2
Radiator	Coolant									Hitachi Genuine Long Life Coolant(LLC)

## MAINTENANCE

### List of Consumable Parts

#### Filter Elements

	Part No.	
	ZX17U-6,19U-6	ZX26U-6
Full-Flow Filter	4454705	4129280
Hydraulic Oil Suction Filter	4479355	4617512
Pilot Filter	4294130	4294130
Engine Oil Filter	4661289	4661289
Fuel Filter	YD00009610	4667073
Water Separator	YD00009611	YD00009611
Air Cleaner Filter	4383875	4417516
Fan Belt	4664734	4664734

#### Bucket Parts

		Part No.		Quantity
		ZX17U-6,19U-6	ZX26U-6	
Tooth	Tooth	4080730	4080730	3
	Lock Pin	4080731	4080731	3
	Lock Rubber	4080732	4080732	3
Side Cutter	Side Cutter (right side)	4626441	4626441	1
	Side Cutter (left side)	4626442	4626442	1
	Bolts	J921440	J921440	6
	Spring Washer	A590914	A590914	6
	Nut	J950014	J950014	6
O-ring		4275463	4275520	(4)

 **NOTE**

The quantity row in the table above represents the number of parts used for one bucket. The quantity may vary with optional buckets.

The quantity inside parentheses () for O-rings includes those for arm and link connections.

# MAINTENANCE

## A. Greasing

### 1 Front Joint Pins

#### Bucket and Link Pin

Grease--- every 100 hours

#### Swing post and Others

--- every 500 hours or every year

(Every 100 hours for the 1st 500 hours)

Lubricate all grease fittings shown at right.



M1M7-05-024 ja

- Bucket and Link Pins

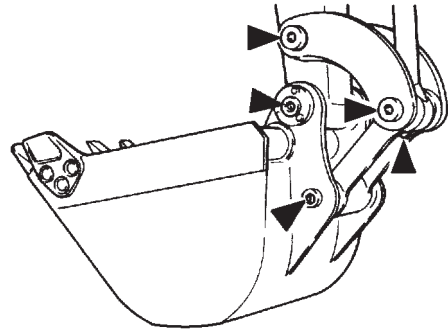

M503-07-092 ja

- Boom Cylinder Bottom Side

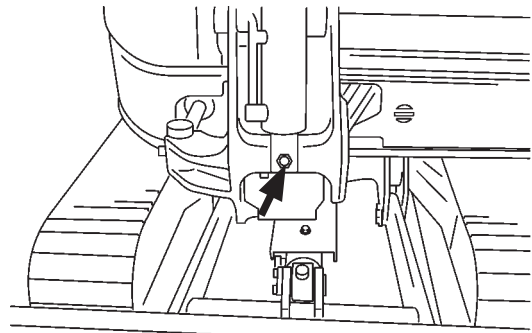

M1M7-07-021-1 ja

- Boom Cylinder Rod Side

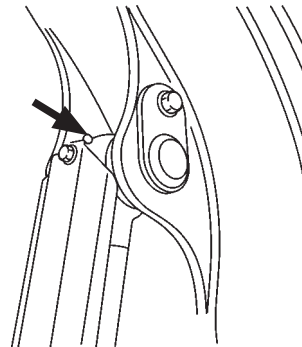

M1M7-07-020-1 ja

## MAINTENANCE

---

- Boom Foot

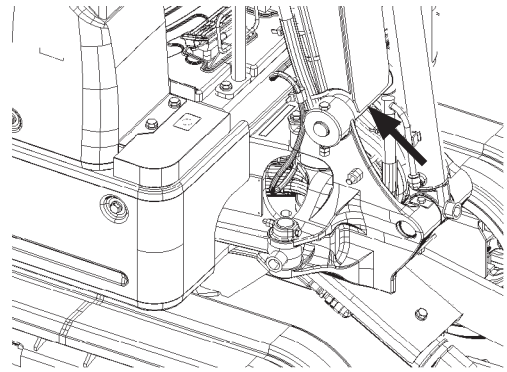

ZX17U-6, 19U-6

MABA-00-001-1 ja

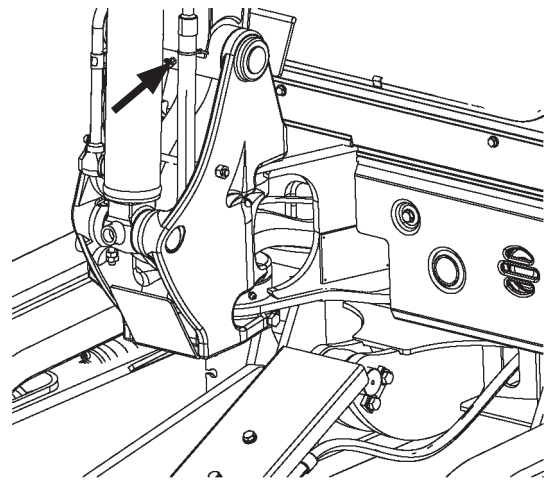

ZX26U-6

MABC-07-005-1 ja

- Arm Cylinder Rod Side, Bucket Cylinder Bottom Side

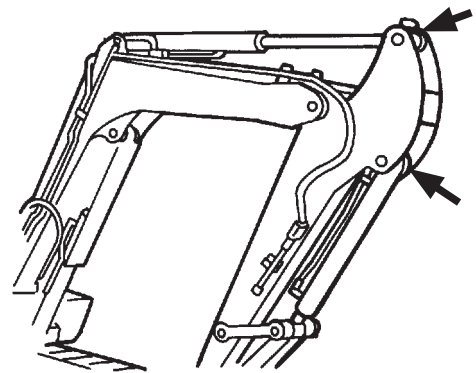

M571-07-006-1 ja

# MAINTENANCE

- Boom and Arm Joint Pins, Arm Cylinder Bottom Side

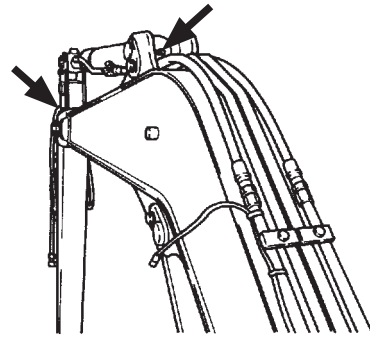

M585-07-046-1 ja

- Swing Cylinder

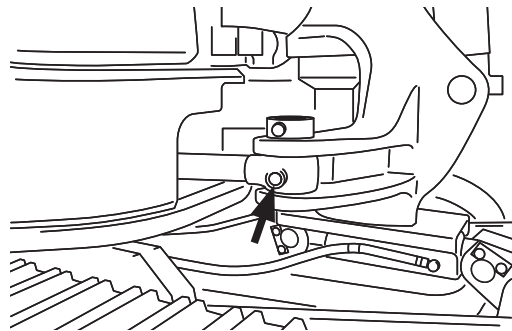

MABK-07-014-1 ja

- Swing Post

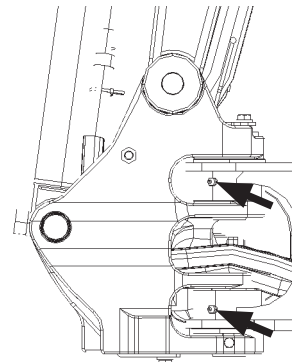

MABA-07-014-1 ja

## 2 Blade Pins (ZX26U-6)

••• every 500 hours (first time after 250 hours) or every year

- Blade Joint Pins

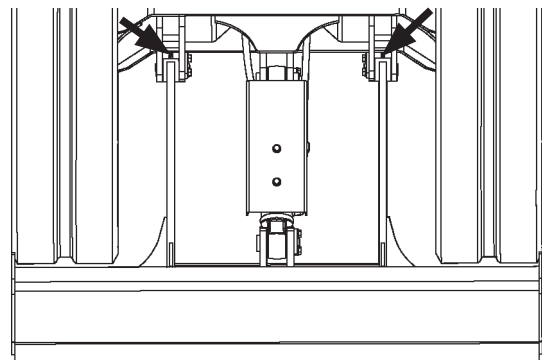

ZX26U-6

MABC-07-004-1 ja

## MAINTENANCE

### 3 Swing Bearing

--- every 250 hours

#### CAUTION

Lubricating both the swing bearing and gear, and rotating the upperstructure must be done by one person. Before you lubricate the swing bearing, clear the area of all persons. Before lubricating the machine, lower the bucket to the ground, stop the engine and pull the pilot control shut-off lever to the LOCK position.

1. Park the machine according to the instructions of (7-6) Preparations for Inspection and Maintenance.
2. Lubricate the parts via the fittings (1) shown in the figure. The appropriate amount of grease is expelled with two or three strokes of the grease gun.
3. Confirm that the pilot control shut-off lever is pulled to the UNLOCK position before starting the engine.
4. Raise the bucket approx. 200 mm above the ground and rotate the upperstructure 90°.
5. Lower the bucket to the ground.
6. Repeat steps 1 to 5 above 8 times.
7. Apply grease to the swing bearing until grease can be seen escaping from the swing bearing seals. Take care not to supply excessive grease.

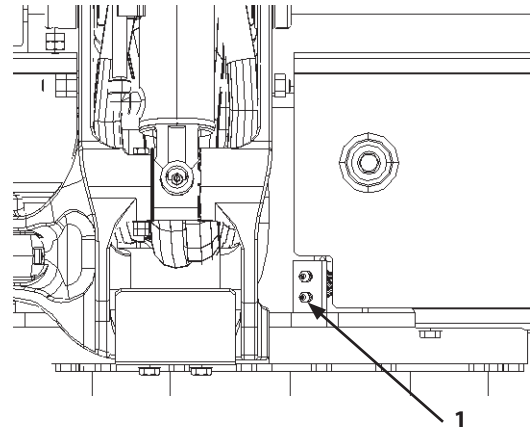

ZX17U-6, 19U-6

MABA-07-015-1 ja

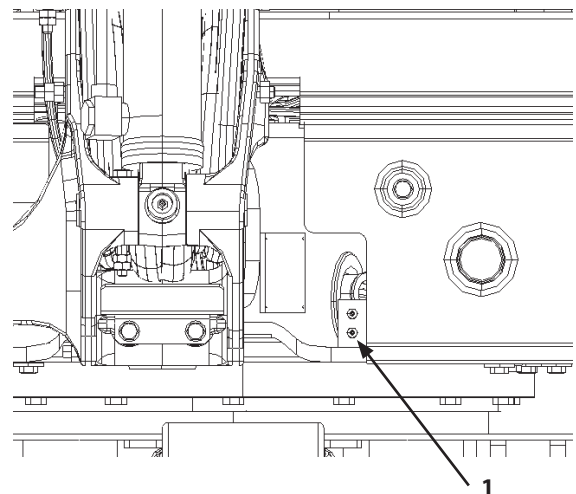

ZX26U-6

MABA-07-016-1 ja

## MAINTENANCE

### 4 Swing Internal Gear

--- every 500 hours

#### **CAUTION**

**Lubricating both the swing bearing and gear, and rotating the upperstructure must be done by one person. Before you lubricate the swing bearing, clear the area of all persons. Before lubricating the machine, lower the bucket to the ground, stop the engine and pull the pilot control shut-off lever to the LOCK position.**

1. Park the machine according to the instructions of (7-6) Preparations for Inspection and Maintenance.
2. Remove the cover from the bottom center of the undercarriage, check if grease is cloudy due to water or mud.
3. Lubricate the parts via the fittings (1) shown in the figure.
4. Confirm that the pilot control shut-off lever is pulled to the UNLOCK position before starting the engine.
5. Raise the bucket approx. 200 mm above the ground and rotate the upperstructure 90°.
6. Lower the bucket to the ground.
7. Repeat the procedure (Step 1 to 6) four times.
8. Apply grease in the quantities shown in the table below. If the grease is contaminated, remove all the old grease and replace with new grease. Take care not to supply excessive grease.

	Grease Qty.	Total Grease Capacity
ZX17U-6, 19U-6	0.2 L	0.6 L
ZX26U-6	0.2 L	3.0 to 3.3 L

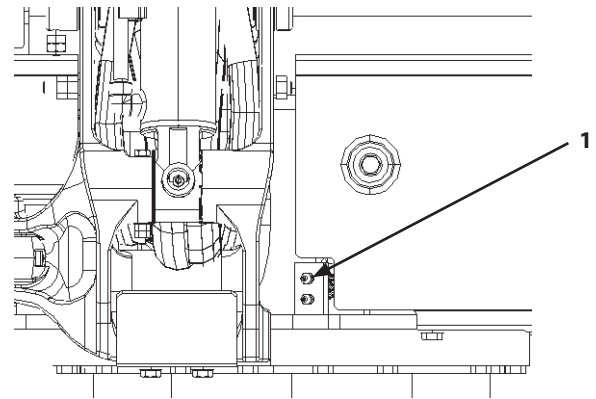

ZX17U-6, 19U-6

MABA-07-015-2 ja

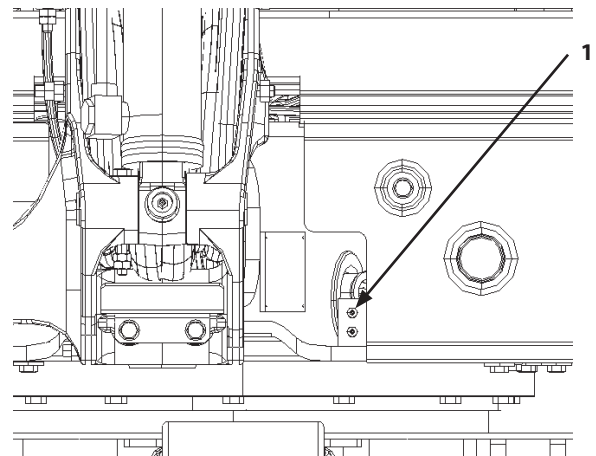

ZX26U-6

MABA-07-016-2 ja



## MAINTENANCE

---

### 5 Control Lever Universal Joint

--- every 500 hours or every year

Lift up the rubber boots of the left and right control levers in turn and apply grease to the 4 places indicated by the arrows, which are the pilot valve pushers.

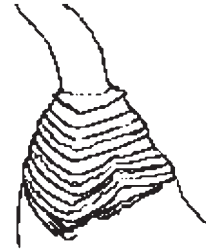

MADB-07-010 ja

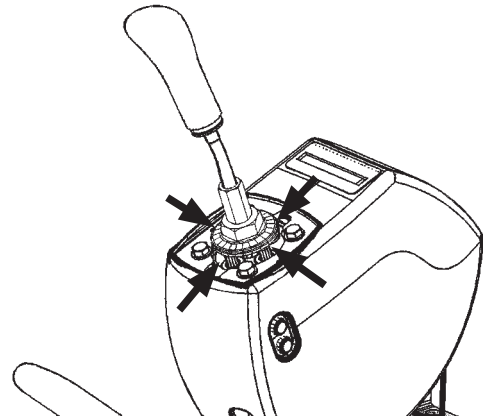

M1M7-07-016-1 ja

# MAINTENANCE

## B. Engine

### 1 Check Engine Oil Level

--- daily (before starting the engine)

#### IMPORTANT

This machine uses a closed air breather system. An incorrect engine oil level may cause problems with the engine. (The oil level should be between the upper and lower marks on oil level gauge (1).) If the engine oil level exceeds the upper limit as well, adjust the oil level to the proper quantity before starting the engine.

Check the oil level before starting the engine. Open the engine cover and pull out oil level gauge (1). Wipe oil level gauge (1) with a cloth and reinsert it into the pipe to the end, and then pull it out again.

The oil level should be between the upper and lower marks on oil level gauge (1).

If the oil level is below the lower limit mark, add the recommended engine oil via oil filler (2).

If the oil level is above the upper limit mark, remove drain plug (3) at the bottom of the engine oil pan to drain oil.

#### CAUTION

Avoid spillages when adding oil. Spilled oil may cause fires.

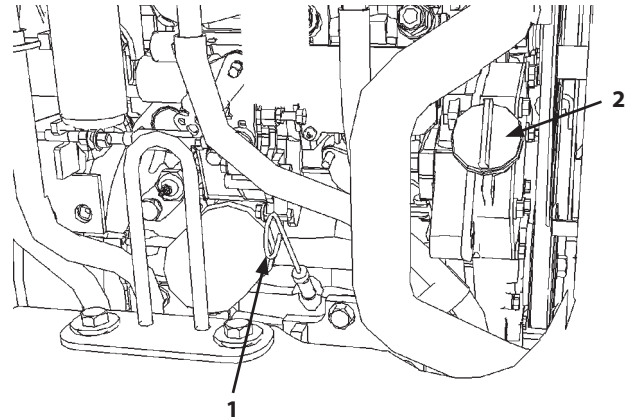

ZX17U-6, 19U-6

M1M5-07-009-1 ja

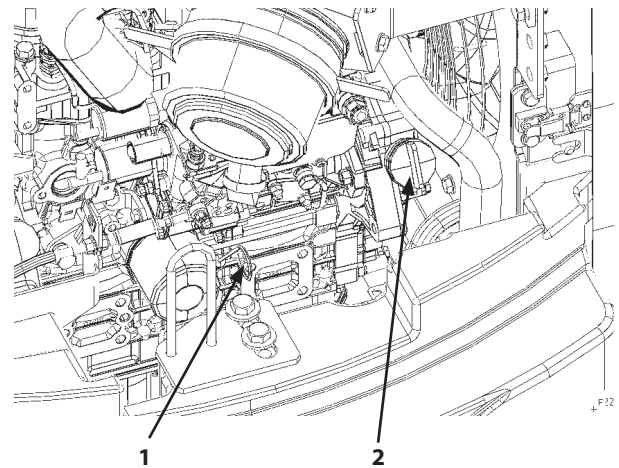

ZX26U-6

MABA-07-017-1 ja

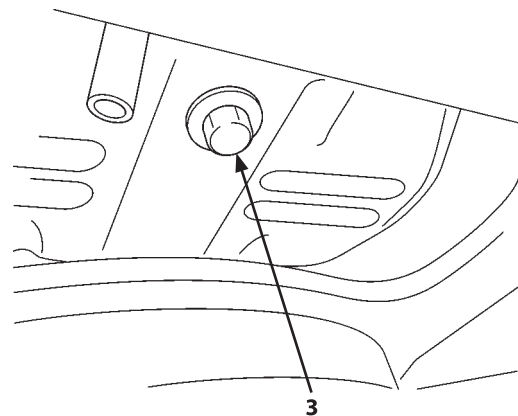

M1M7-07-029-1 ja

## MAINTENANCE

### 2 Change Engine Oil

--- every 250 hours

### 3 Replace Engine Oil Filter

--- every 250 hours

1. Park the machine according to the instructions of (7-6) Preparations for Inspection and Maintenance.

#### CAUTION

**Engine oil may be hot just after operation. Wait for oil to cool before starting work.**

2. Place a 10 liter container under the engine oil pan. Remove oil filler cap (2).
3. Remove drain plug (3) to drain the oil.
4. Filter oil through a clean cloth into the container.

ZX17U-6, 19U-6: 2.8 L

ZX26U-6: 3.5 L

5. After all oil has been drained, inspect the cloth for any debris such as small pieces of metal.
6. Securely tighten drain plug (3).

Wrench size: 17 mm

Tightening Torque: 30 N·m (3 kgf·m)

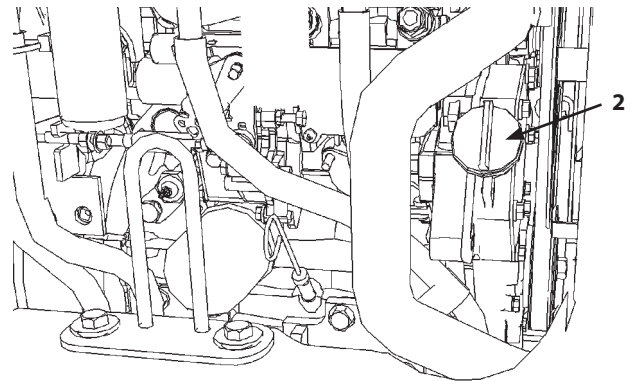

ZX17U-6, 19U-6

M1MS-07-009-2 ja

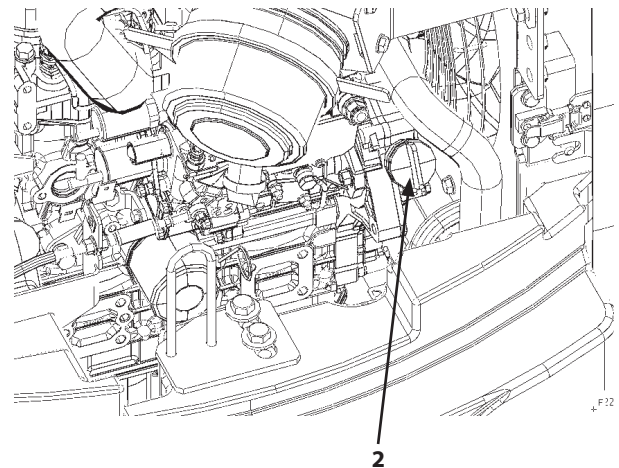

ZX26U-6

MABA-07-017-2 ja

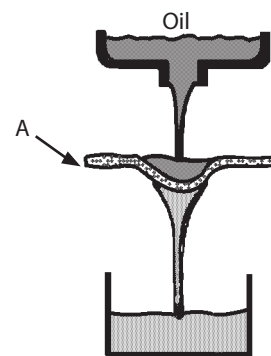

A: Clean Cloth

M104-07-010-2 en\_GB

## MAINTENANCE

- Use a filter wrench to remove oil filter (4) by turning it counterclockwise.  
When doing so, catch oil spilled from oil filter (4) with an empty container.
- Clean the filter cartridge contact area on the machine.

### IMPORTANT

- When putting new oil in the cartridge element, take care that no foreign objects get into the engine.**
  - Do not reuse engine oil filter (4). Use a genuine engine oil filter (4). Failure to use genuine parts or failure to replace the oil filter may result in problems with the engine.**
- Apply a thin layer of engine oil to the gasket (O-ring) of the new oil filter (4).
  - Install new oil filter (4). Turn the filter cartridge clockwise by hand until the gasket touches the contact area. Be sure not to damage the gasket when installing filter (4).
  - Tighten engine oil filter 3/4 of one turn using the filter wrench. Be careful not to overtighten as doing so may deform the oil filter (4).

Tightening Torque: 20 to 24 N·m  
(2.0 to 2.4 kgf·m)

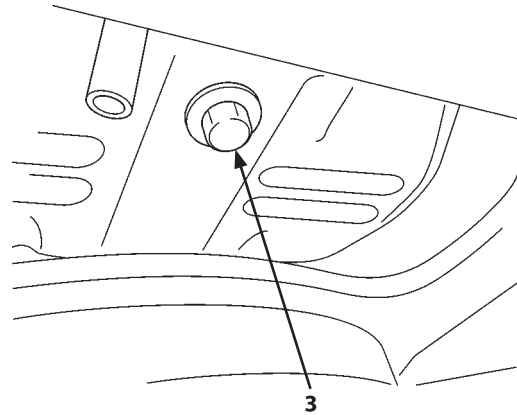

M1M7-07-029-1 ja

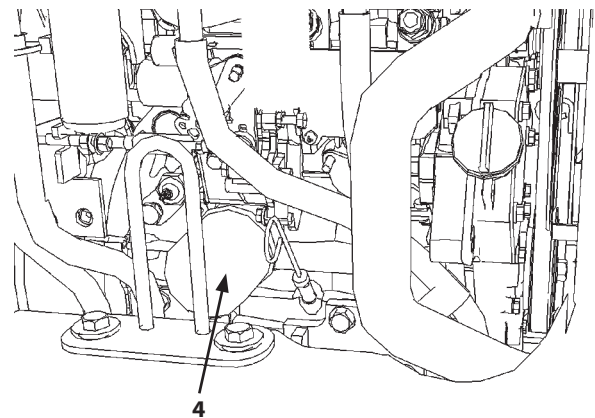

ZX17U-6,19U-6

M1M5-07-009-3 ja

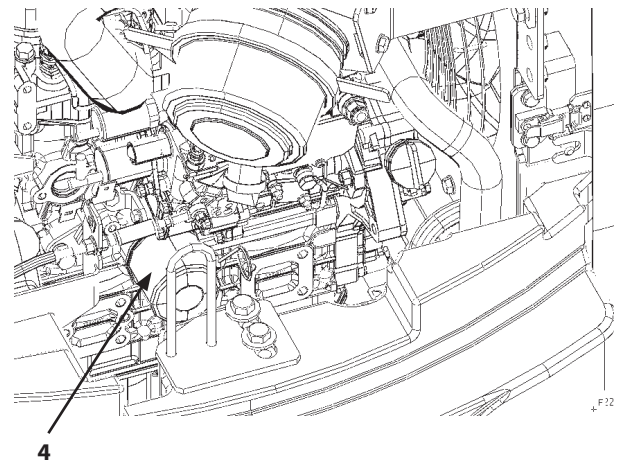

ZX26U-6

MABA-07-017-3 ja

## MAINTENANCE

### CAUTION

**Avoid spillages when adding oil. If oil is spilled, wipe it up. If spilled oil is left as-is, it may lead to a fire.**

12. Remove oil filler cap (2) and fill with the specified amount of engine oil. After 15 minutes, pull out dipstick (1) and check that the level is between the minimum and maximum levels.

### NOTE

*Refer to (7-20) Kinds of Oils for the type of oil to use.*

13. Install new oil filter (2).
14. Start the engine. Run the engine at slow idle for 5 minutes.
15. Stop the engine. Remove the key from the key switch.
16. Check for any leakage.
17. After 15 minutes, check the level and add or drain oil to ensure that the level is between the minimum and maximum levels. (The oil level should be between the upper and lower marks on the oil level gauge). (Refer to 7-30)

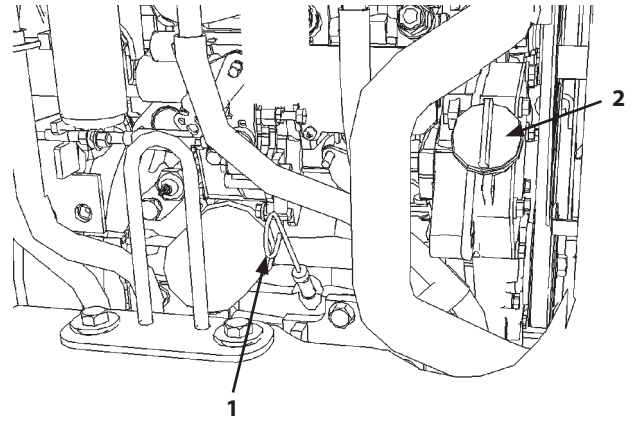

ZX17U-6, 19U-6

M1MS-07-009-1 ja

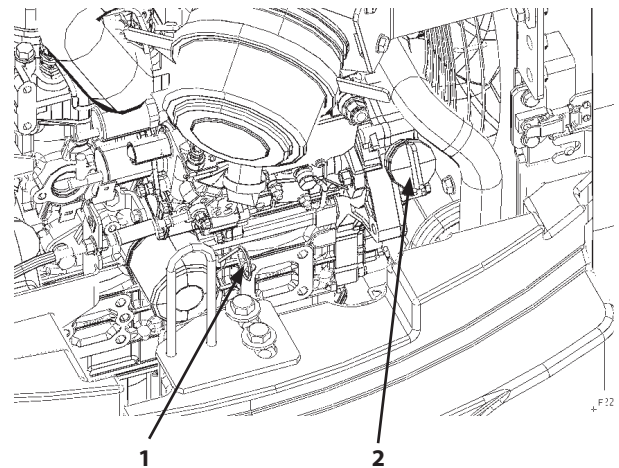

ZX26U-6

MABA-07-017-1 ja

## MAINTENANCE

### C. Transmission

#### 1 Gear Oil in Travel Reduction Gear

##### Check Oil Level --- every 250 hours

1. Park the machine on a level surface.
2. Rotate the travel motor until the plugs are positioned as illustrated on the right.
3. Park the machine according to the instructions of (7-6) Preparations for Inspection and Maintenance.

#### WARNING

**Keep body and face away from the air release plug. Gear oil may be hot just after operation. Wait for gear oil to cool and then gradually loosen the air release plug to release pressure.**

4. Once the oil is cool, slowly loosen plug (1) to release pressure.
5. Remove air release plug (1), and oil level check plug (2); oil must be up to the bottom of the hole.
6. Add oil until oil flows out of the oil level check plug (2) hole.
7. Clean and tighten the plugs (1) and (2).

Tightening Torque: 29 to 39 N·m  
(3 to 4 kgf·m)

8. Repeat steps for the other travel device.

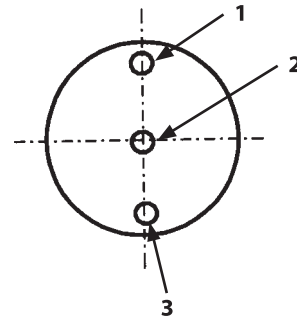

M503-07-015-1 ja

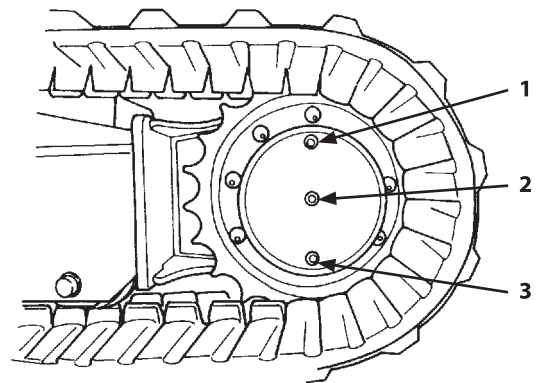

M585-07-080-1 ja

##### Change Gear Oil --- every 1000 hours

#### IMPORTANT

**Do not use gear oils other than those listed in the "Brand Names of Recommended Oil".**

1. Park the machine on a level surface.
2. Rotate the travel motor until the plugs are positioned as illustrated on the right.
3. Park the machine according to the instructions of (7-6) Preparations for Inspection and Maintenance.

#### WARNING

**Keep body and face away from the air release plug. Gear oil may be hot just after operation. Wait for gear oil to cool and then gradually loosen the air release plug to release pressure.**

4. After gear oil has cooled, slowly loosen air release plug (1) to release pressure. Temporarily retighten plug (1).

## MAINTENANCE

5. Remove drain plug (3) and plug (1), in that order to drain gear oil.
6. Clean drain plug (3) and tighten it.

Tightening Torque: 29 to 39 N·m  
(3 to 4 kgf·m)

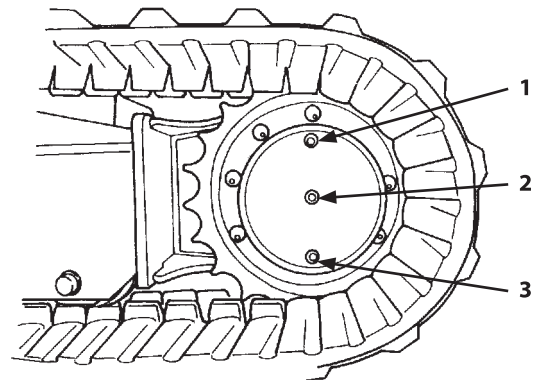

M585-07-080-1 ja

7. Remove oil level check plug (2).
8. Add oil until oil flows out of oil level check plug (2) hole.

Model	Oil Quantity
ZX17U-6, 19U-6	0.25 L
ZX26U-6	0.60 L

**NOTE**

*Refer to (7-20) Kinds of Oils for the type of oil to use.*

9. Clean and tighten the plugs (1) and (2).

Tightening Torque: 29 to 39 N·m  
(3 to 4 kgf·m)

10. Repeat steps 2. to 9. for the other travel device.

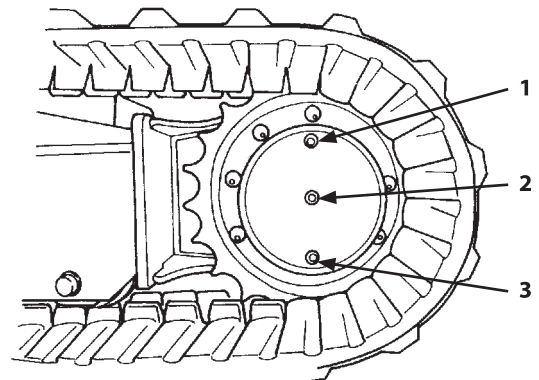

M585-07-080-1 ja

# MAINTENANCE

---

## D. Hydraulic System

### Inspection and Maintenance of Hydraulic Equipment

#### CAUTION

**When checking and/or servicing hydraulic components, pay special attention to the following points.**

1. Park the machine according to the instructions of (7-6) Preparations for Inspection and Maintenance.
2. Prior to inspecting or servicing the hydraulic system, relieve the residual pressure and allow the parts to cool.
  - a. Relieve the residual pressure in the various lines, such as the boom, arm and bucket cylinder circuits, swing lines, pilot system lines, etc.
  - b. Air bleed the hydraulic oil tank.
  - c. Immediately after operation, all hydraulic components and hydraulic oil or lubricants are hot and highly pressurized. Begin inspection and/or maintenance work only after the machine has cooled down. Servicing heated and pressurized hydraulic components may cause plugs, screws and/or oil to fly off or escape suddenly, potentially resulting in personal injury. Hydraulic components may be pressurized even when cool. Keep body parts and face away from the front of plugs or screws when removing them and do so slowly once residual pressure has been released.
  - d. Even after air pressure in the hydraulic oil tank is released, if the machine is parked on a slope, the oil pressure in the travel motor and the swing motor circuits stay at high pressure as the reaction force of the machine's own weight is constantly applied to the travel motor. Never check and/or service the machine while parked on a slope.

#### IMPORTANT

- **When connecting hydraulic hoses and pipes, take special care to keep seal surfaces free from dirt and to avoid damaging them.**
- **Wash hoses, pipes, and the tank interior with a washing liquid and thoroughly wipe off before reconnecting.**
- **Only use O-rings that are free of damage or defects. Be careful not to damage them during reassembly. Do not allow high pressure hoses to twist when connecting them. If twisted, hose life is shortened considerably.**
- **Do not use hydraulic oils other than those listed in the table "Brand names of recommended hydraulic oil".**
- **When adding hydraulic oil, always use the same brand of oil; do not mix brands of oil. When using another manufacturer's hydraulic oil, be sure to change all of the oil.**
- **Never run the engine without oil in the hydraulic oil tank.**



## MAINTENANCE

### Change Hydraulic Oil and Replace Full-Flow Filter Element

Hydraulic breaker operation causes the hydraulic system to become contaminated faster and quickly deteriorates the hydraulic oil.

Failure to adhere to proper maintenance intervals may result in damage to the base machine and the breaker. In order to extend service life, particularly that of the hydraulic pump, change the hydraulic oil and the full-flow filter element at the specified frequency given below.

Hydraulic oil change intervals vary according to the kind of hydraulic oils used. Refer to the section (7-21) Brand Names of Recommended Hydraulic Oils.

#### Replacement Interval when Using a High Performance Filter (ZX26U-6) (Optional)

Breaker Operating Ratio	0 %	10 %	20 %	30 %	40 %	50 %	60 %	70 %	80 %	90 %	100 %
Full-Flow Filter	1000	670	510	410	340	290	250	215	195	180	170
1500 Hour Hydraulic Oil	1500	1260	1100	980	895	820	760	700	640	600	560
3000 Hour Hydraulic Oil	3000	2300	1850	1500	1250	1080	935	800	710	630	560

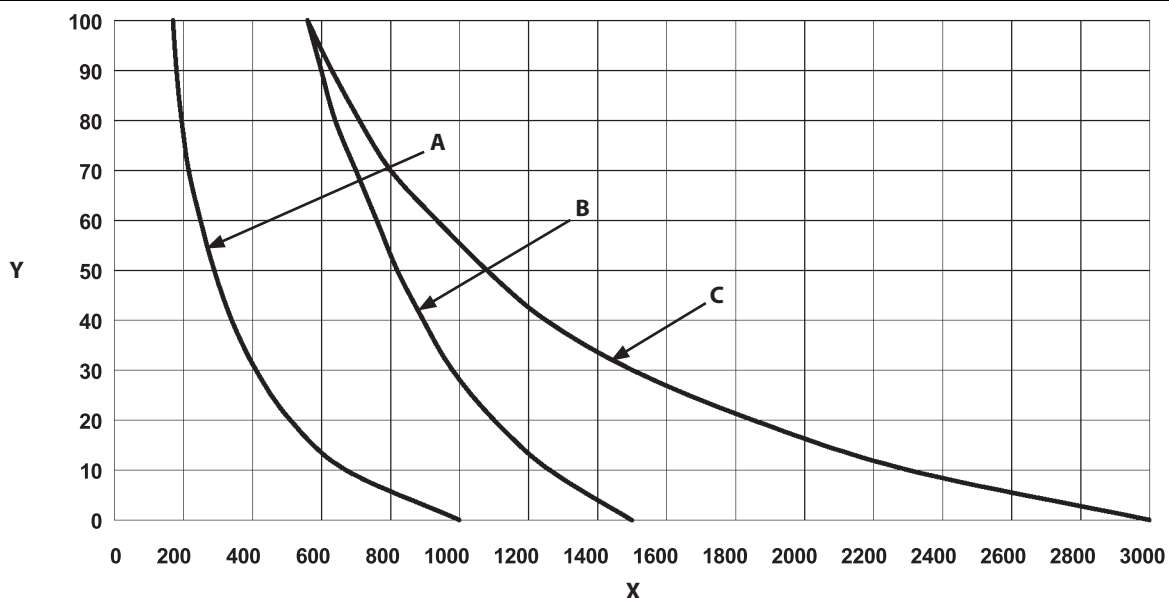

MADR-07-008-1 ja

- A: Element Replacement Intervals      B: Change Interval for 1500-Hour Hydraulic Oil      C: Change Interval for 3000-Hour Hydraulic Oil      Y: Breaker Operating Ratio (%)  
 X: Change Interval (Hours)

# MAINTENANCE

Change Interval for Standard Full-Flow Filters (Hours)

Breaker Operating Ratio	0 %	10 %	20 %	30 %	40 %	50 %	60 %	70 %	80 %	90 %	100 %
Full-Flow Filter	500	180	115	95	85	75	70	65	60	55	50
1000 Hour Hydraulic Oil	1000	720	580	500	450	410	380	360	340	330	320
2000 Hour Hydraulic Oil	2000	1310	980	780	650	550	480	430	385	350	320

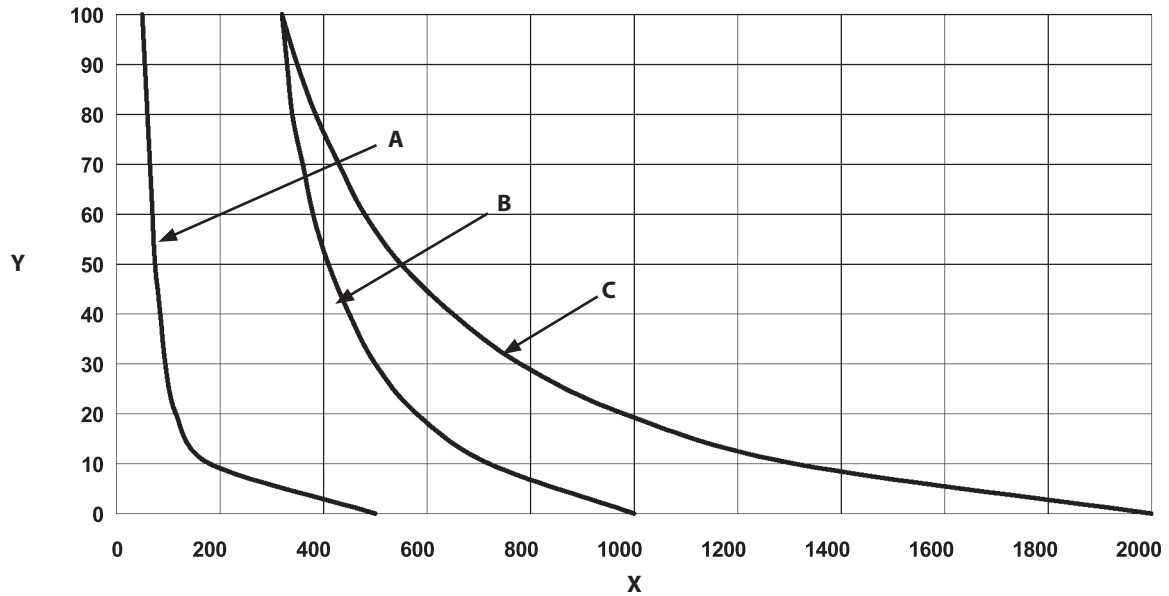

MADR-07-009-1 ja

- A: Element Replacement Intervals      B: Change Interval for 1000-Hour Hydraulic Oil      C: Change Interval for 2000-Hour Hydraulic Oil      X: Change Interval (Hours)  
 Y: Breaker Operating Ratio (%)

# MAINTENANCE

## 1 Check Hydraulic Oil Level

--- daily

### IMPORTANT

If the oil level cannot be seen in level gauge (1), immediately refill hydraulic oil up to the appropriate level. Failure to do so may result in a serious failure in the hydraulic system. If the oil level is higher than level gauge (1), remove oil down to the appropriate level with a pump.

1. Park the machine according to the instructions of (7-6) Preparations for Inspection and Maintenance.
2. Check oil level with level gauge (1) on hydraulic oil tank. Oil must be between the marks on gauge (1). If necessary, add oil.



M1M7-05-024 ja

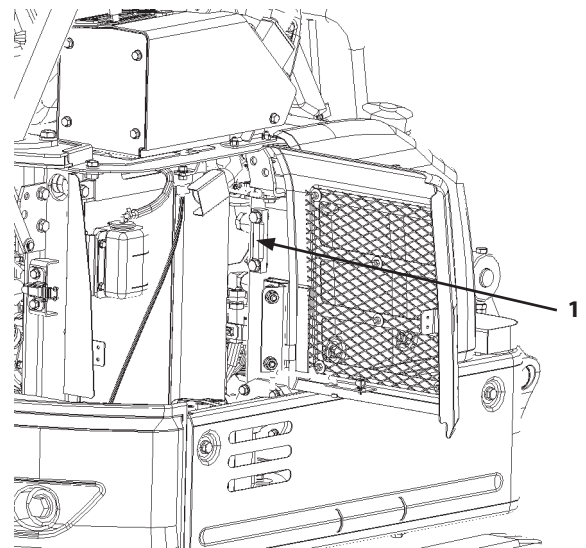

ZX17U-6,19U-6

MABA-07-018-1 ja

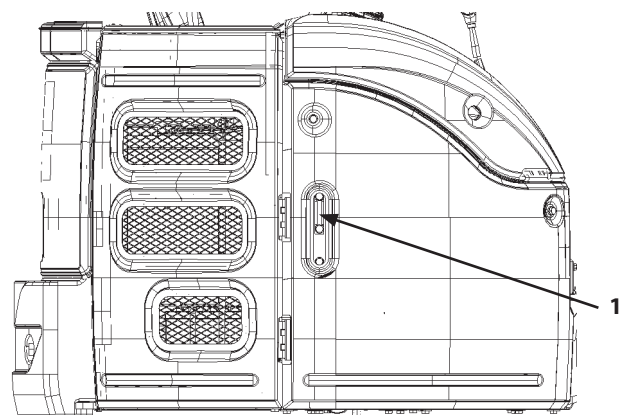

ZX26U-6

MABA-07-019-1 ja

## MAINTENANCE

### 2 Drain Hydraulic Oil Tank Sump

--- every 250 hours

#### WARNING

Hydraulic oil becomes hot and is under pressure during operation. Severe burns may result if skin comes in contact with escaping hydraulic oil just after operation. Wait for the oil to cool before starting any maintenance work.

1. Park the machine according to the instructions of (7-6) Preparations for Inspection and Maintenance.
2. Let the machine sit for awhile without operating it until hydraulic oil cools, then bleed air pressure from the hydraulic oil tank.
3. Slowly loosen drain plug (1) to drain water and sediment.



M1M7-05-024 ja

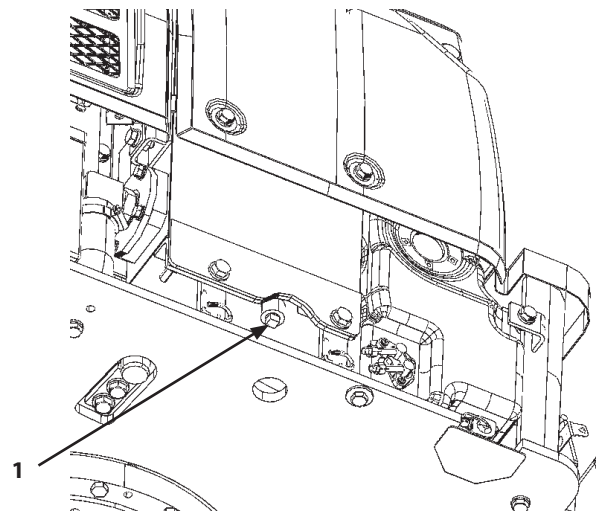

ZX17U-6, 19U-6

MABA-07-020-1 ja

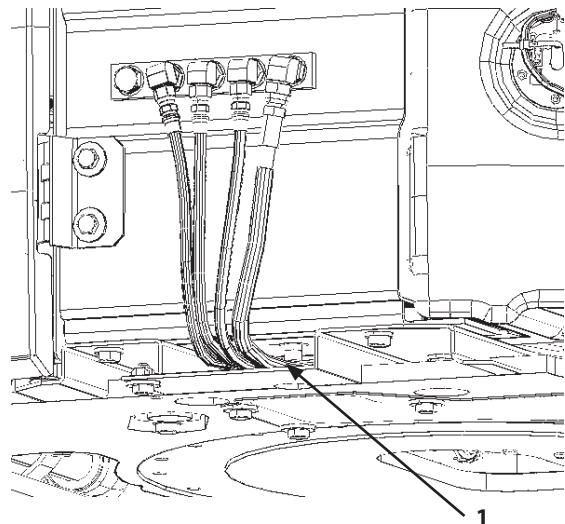

ZX26U-6

MABA-07-021-1 ja

## MAINTENANCE

---

### 3 Change Hydraulic Oil

--- every 1000 hours or 2000 hours

When using high performance element

--- every 1500 hours or 3000 hours

### 4 Cleaning the Suction Filter

---each time hydraulic oil is changed

#### IMPORTANT

The change interval depends on the brand of hydraulic oil used, kind of filter element and average attachment operating rate. For more details, refer to the section (7-59), Changing Hydraulic Oil and Replacing Full-Flow Filter Element.

#### CAUTION

Hydraulic oil becomes hot and is under pressure during operation. Severe burns may result if skin comes in contact with escaping hydraulic oil just after operation. Wait for the oil to cool before starting any maintenance work.



M1M7-05-024 ja

1. Park the machine according to the instructions of (7-6) Preparations for Inspection and Maintenance.

## MAINTENANCE

2. Open the tank cover and clean the top of the hydraulic oil tank to keep dirt out of the hydraulic system.
3. Loosen cap (1) to release pressure from the hydraulic oil tank.
4. Remove cap (2) of the filler port.

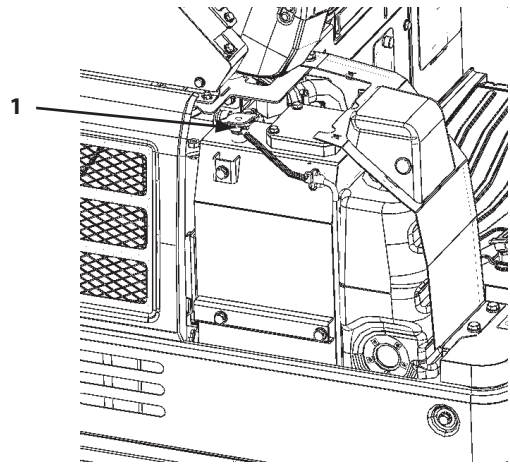

ZX17U-6, 19U-6

MABA-07-022-1 ja

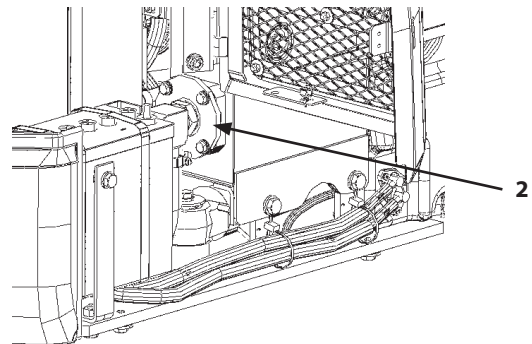

ZX17U-6, 19U-6

MABA-07-023-1 ja

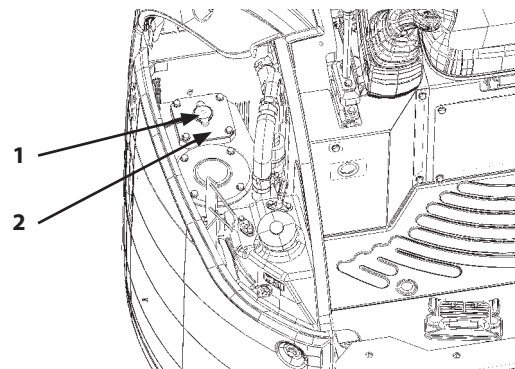

ZX26U-6

MABK-07-012-1 ja

## MAINTENANCE

### ZX17U-6,19U-6

1. Remove oil using a suction pump. The capacity of the hydraulic oil tank is approximately 26 L when at the top of the specified oil level.
2. Slowly loosen drain plug (3) and allow the oil to drain.
3. After draining the oil, remove suction filter (6) along with cover (2).

### IMPORTANT

**Take care when changing the hydraulic oil that nothing, such as water or sand, gets inside the tank.**

4. Clean the inside of the hydraulic oil tank and suction filter (6).
5. During installation, install suction filter (6) along with cover (2) into the hydraulic oil tank.
6. Clean, install and tighten drain plug (3).
7. Add oil until it is between the marks on the oil level gauge.
8. Bleed air from the hydraulic system.  
(Refer to (7-45) Bleeding Air from the Hydraulic System in 4.)

Wrench size: 13 mm

Tightening Torque: 20 N·m (2 kgf·m)

9. Replace element (6) at regular intervals to keep hydraulic oil clean and to extend the service life of the hydraulic components.

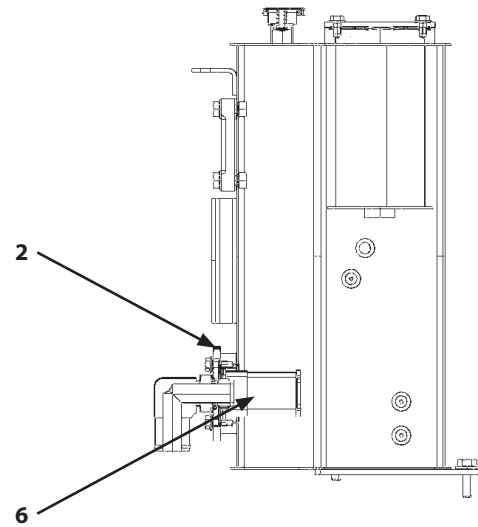

MABA-07-025-1 ja

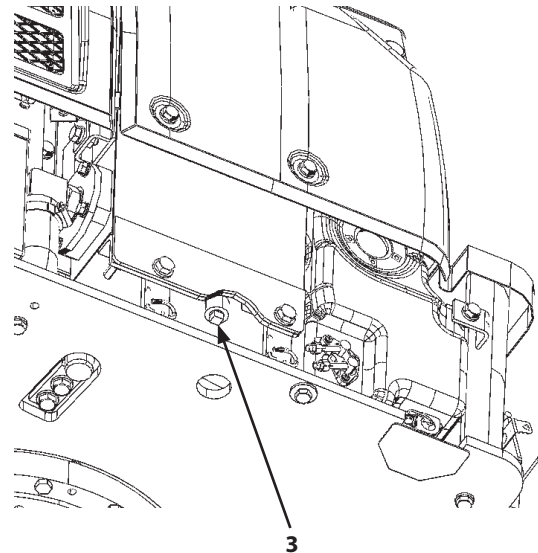

MABA-07-020-2 ja

## MAINTENANCE

### ZX26U-6

1. Remove oil using a suction pump. The capacity of the hydraulic oil tank is approximately 39 L when at the top of the specified oil level.
2. Slowly loosen drain plug (3) and allow the oil to drain.
3. Remove rod assembly (5) from the hydraulic oil tank.

### IMPORTANT

**Take care when changing the hydraulic oil that nothing, such as water or sand, gets inside the tank.**

4. Clean the inside of the hydraulic oil tank and the suction filter. If suction filter (6) is to be replaced, install a new filter on rod (5) as shown.
5. Before installing the suction filter, check the dimensions of the rod assembly shown in the figure on the right, and securely insert it into the pipe.
6. Clean, install and tighten drain plug (3).

Tightening Torque: 50 N·m (5 kgf·m)

7. Add oil until it is between the marks on the oil level gauge.
8. Before securing cover (2) with bolts, ensure the top edge of the rod assembly (5) is completely inserted into the hole of support (4). Make sure filter and rod assembly (5) are in their correct positions, and install cover (2).

Tightening Torque: 10 N·m (1 kgf·m)

9. Bleed air as per Bleeding Air from the Hydraulic System on the next page.
10. Replace element (6) at regular intervals to keep hydraulic oil clean and to extend the service life of the hydraulic components.

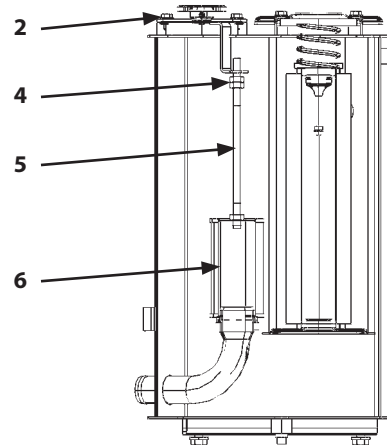

MABA-07-026-1 ja

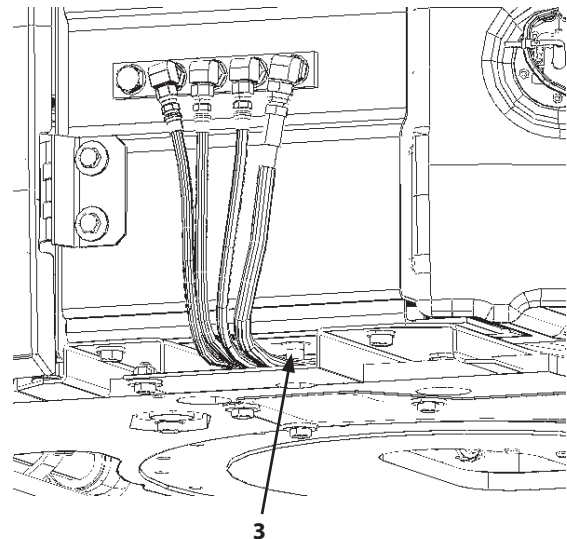

MABA-07-021-2 ja

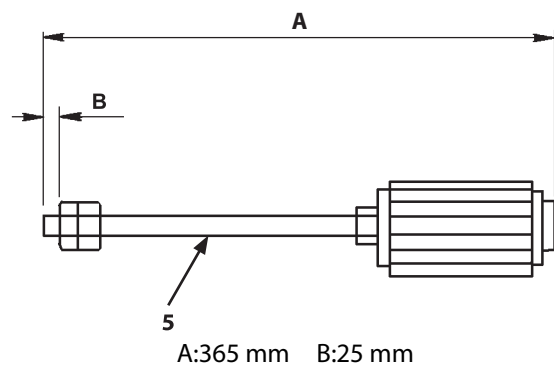

MZX5-07-001-2 ja



## MAINTENANCE

### Bleed Air from Hydraulic System

After changing hydraulic oil, bleed air from the hydraulic system by following the procedures below.

### Bleed Air from Pump

#### IMPORTANT

**If the hydraulic pump is not filled with oil, it will be damaged when the engine is started.**

1. Connect all hydraulic lines to the hydraulic pump. Fill any hydraulic components that can be filled with as much hydraulic oil as possible at this time.
2. Fill the hydraulic oil tank to the specified level.
3. Loosen air bleed plug (1) slightly. Purge air from the pump casing and suction line. Tighten air bleed plug (1) after bleeding air.

Tightening Torque: 30 to 40 N·m  
(3.0 to 4.0 kgf·m)

4. Check all line connections for oil leaks. Set the engine control dial or lever in the slow idle position.
5. Start the engine. Wait 5 to 10 seconds. Stop the engine.

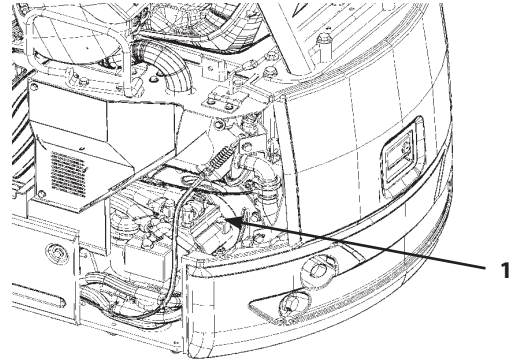

ZX17U-6, 19U-6

MABA-07-027-1 ja

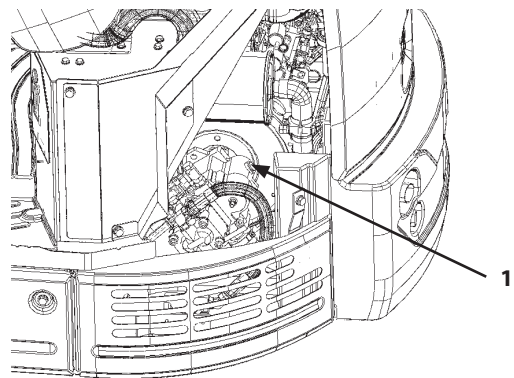

ZX26U-6

MABA-07-028-1 ja

## MAINTENANCE

6. Check the hydraulic oil level with the level gauge located on the side of the hydraulic oil tank. Add hydraulic oil if necessary.
7. Restart the engine. Confirm that the hydraulic oil level in the hydraulic oil tank is sufficient. Run the engine for approximately 1 minute.
8. This is the end of the hydraulic pump air bleeding procedure.

 **NOTE**

*If the hydraulic pump is left empty overnight or longer, be sure to fill the pump with clean hydraulic oil before performing the air bleeding procedure above.*

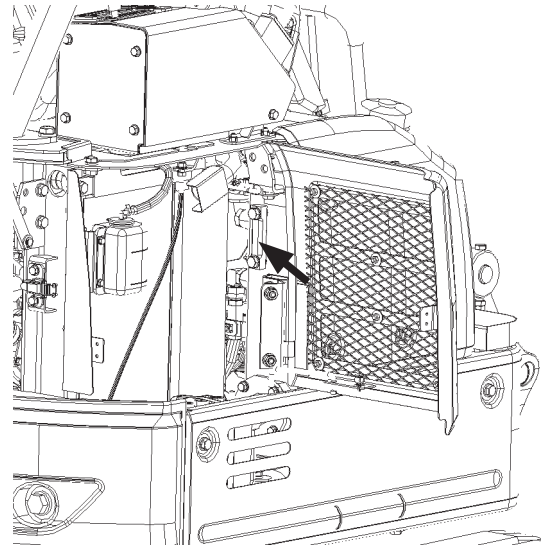

ZX17U-6, 19U-6

MABA-07-018-2 ja

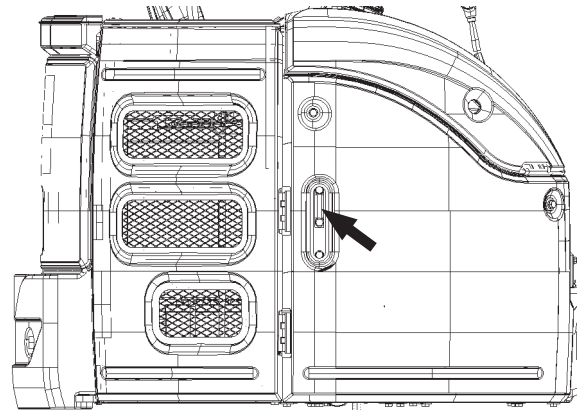

ZX26U-6

MABA-07-019-2 ja

### **Bleed Air From Hydraulic Circuits**

1. After filling hydraulic oil, start the engine. While moving all cylinders and the swing motor evenly, lightly operate the machine for 10 to 15 minutes.
2. Lower the bucket to the ground to return to the position to check hydraulic oil level.
3. Stop the engine. Check hydraulic oil level and add oil if necessary.

## MAINTENANCE

---

### 5 Replace Full-Flow Filter

--- every 500 hours (first time after 250 hours)

When using high performance element

--- every 1000 hours (first time after 500 hours)

#### IMPORTANT

The change interval depends on the brand of hydraulic oil used, kind of filter element and average attachment operating rate. For more details, refer to the section, Changing Hydraulic Oil and Replacing Full-Flow Filter Element.

#### CAUTION

Hydraulic oil becomes hot and is under pressure during operation. Severe burns may result if skin comes in contact with escaping hydraulic oil just after operation. Wait for the oil to cool before starting any maintenance work.



M1M7-05-024 ja

1. Park the machine according to the instructions of (7-6) Preparations for Inspection and Maintenance.

## MAINTENANCE

2. Before replacing element (6), be sure to loosen hydraulic oil tank cap (7) to release residual air pressure from the hydraulic oil tank.
3. Loosen bolts (1) (4 used) to remove cover (2) and O-ring (3). When removing cover (2), slowly remove it while pressing it downward so that spring (4) does not fly off.

### IMPORTANT

**When removing the filter, be aware that the remaining oil in the filter may spill. Take extra care.**

4. Remove spring (4), valve (5) and element (6).
5. Take extra care not to allow water or dust to enter the filter case.
6. Replace O-ring (3) and element (6) with new ones. Be careful not to damage element (6) and O-ring (3). If torn, element (6) cannot be used.
7. Install element (6), valve (5), spring (4) and O-ring (3).
8. Install cover (2) with bolts (1) (4 used).

Tightening Torque: 10 N·m (1 kgf·m)

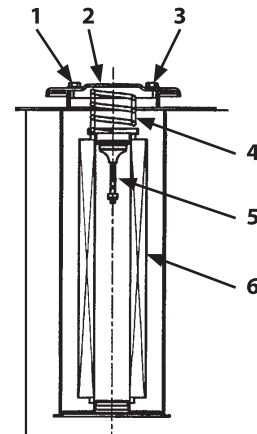

MADB-07-017-1 ja

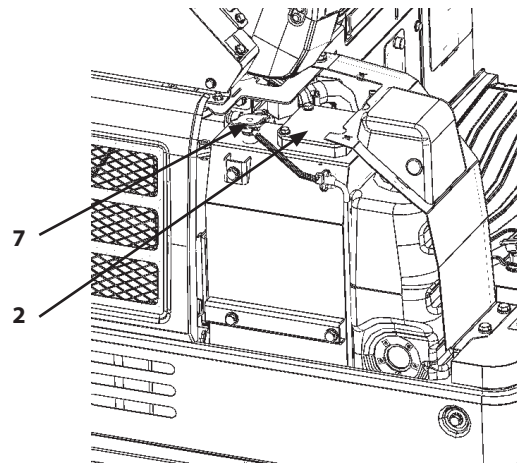

ZX17U-6, 19U-6

MABA-07-022-2 ja

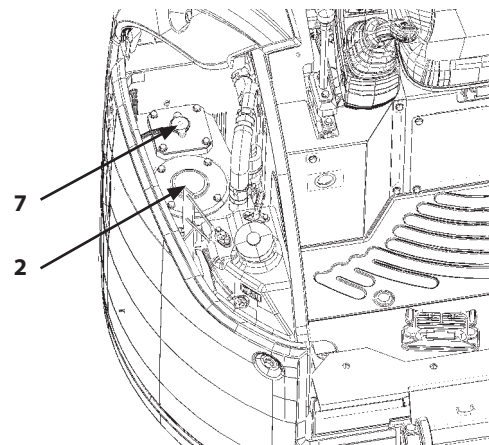

ZX26U-6

MABA-07-024-2 ja

## MAINTENANCE

9. Bleed air from the pump and check the oil level in the hydraulic oil tank after replacing the element. (Refer to (7-45) Bleeding Air from the Hydraulic System.)

If the machine is operated with air mixed in the hydraulic circuit, it may damage the pump.

10. Replace element (6) at regular intervals to keep the hydraulic oil clean and to extend the service life of the hydraulic components.

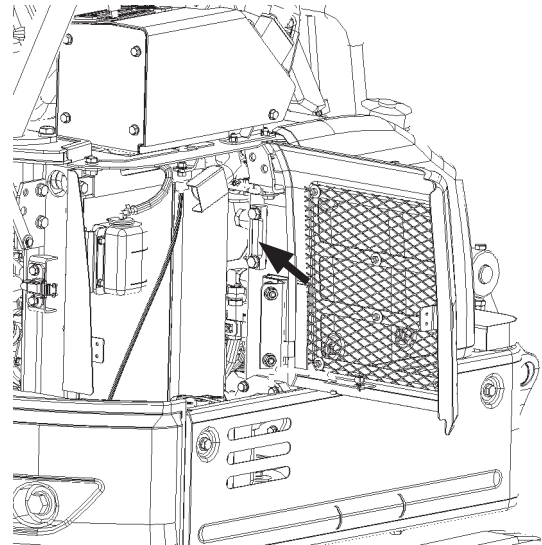

ZX17U-6, 19U-6

MABA-07-018-2 ja

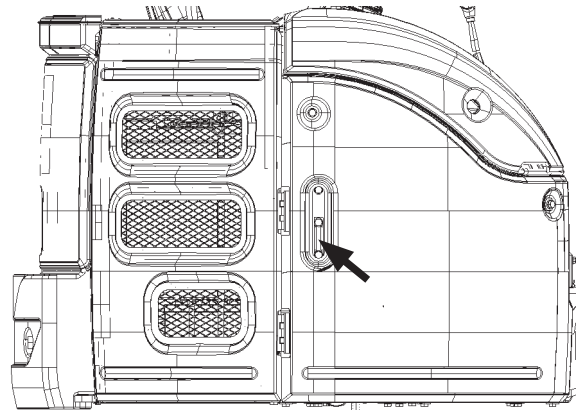

ZX26U-6

MABA-07-062-2 ja

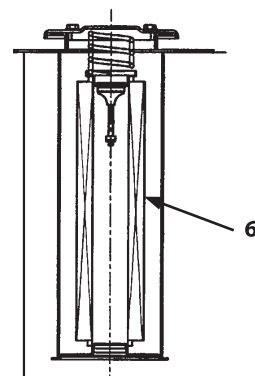

MADB-07-017-2 ja

# MAINTENANCE

## 6 Replace Pilot Oil Filter Element

--- every 1000 hours

### **WARNING**

Hydraulic oil becomes hot and is under pressure during operation. Severe burns may result if skin comes in contact with escaping hydraulic oil just after operation. Wait for the oil to cool before starting any maintenance work.



M1M7-05-024 ja

1. Park the machine according to the instructions of (7-6) Preparations for Inspection and Maintenance.
2. Before replacing the element, be sure to loosen the hydraulic oil tank cap (1) to release the residual air pressure from the hydraulic oil tank.

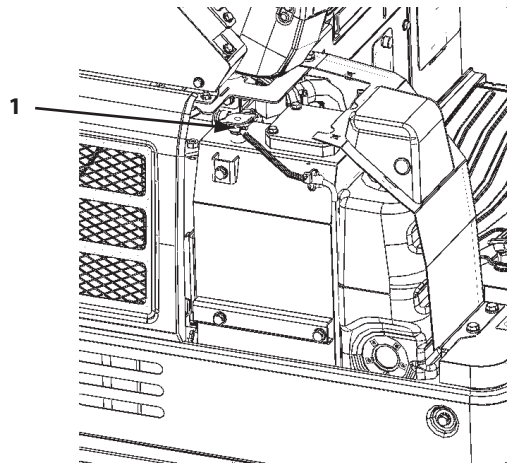

ZX17U-6, 19U-6

MABA-07-022-1 ja

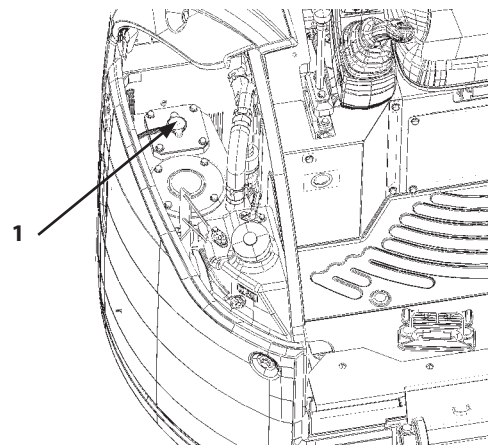

ZX26U-6

MABA-07-024-3 ja

## MAINTENANCE

3. Remove bolts (3) and under cover (2) of rear left side.

Wrench size: 17 mm

4. Rotate filter case (6) of pilot filter (4) counterclockwise to remove the filter case.
5. While rotating filter element (7), pull it downward and remove it.
6. Replace O-ring (8) with a new one.
7. Clean the filter O-ring (8) contact area on filter head (5).

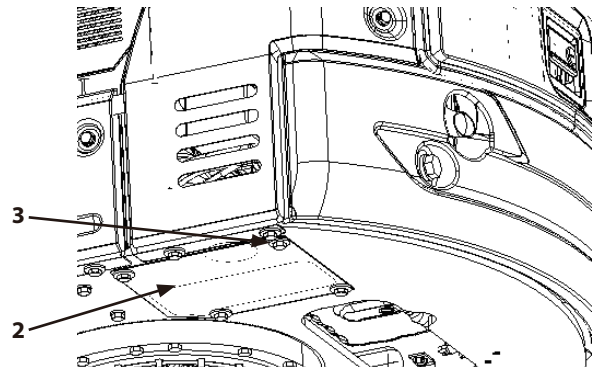

ZX17U-6, 19U-6

MABK-07-005-1 ja

8. Securely install O-ring (8) in the O-ring groove on head cover (5).
9. Coat the seal on new filter element (7) with clean hydraulic oil. Completely install element (7) into head cover (5) while rotating and taking care not to damage it.
10. Take care not to allow dust and/or water enter filter case (6).
11. Install case (6) into head cover (5) while rotating it clockwise.

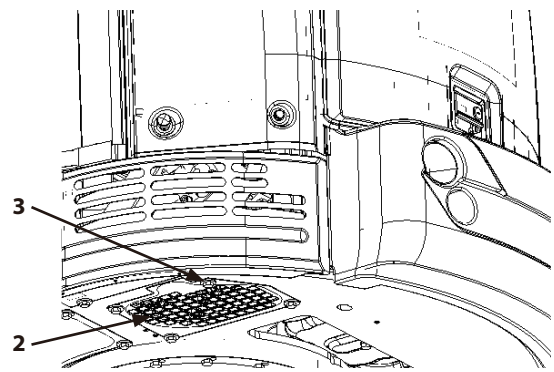

ZX26U-6

MABK-07-006-1 ja

Tightening Torque: 25 to 35 N·m  
(2.5 to 3.5 kgf·m)

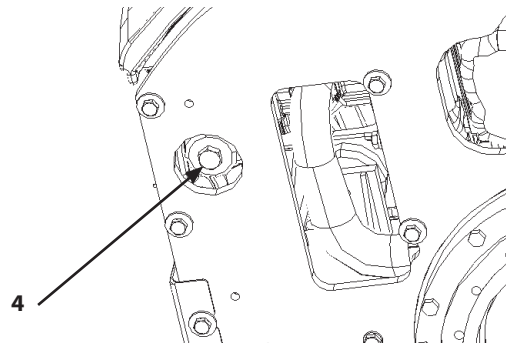

MABK-07-007-1 ja

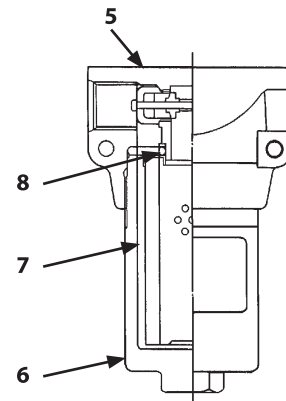

M503-07-031-1 ja

## MAINTENANCE

12. After replacing filter element, bleed any remaining air from the hydraulic circuit.  
(Refer to (7-45) Bleeding Air from the Hydraulic System.)

If the machine is operated with air mixed in the hydraulic circuit, it may damage the pump.

13. Replace element (5) at regular intervals to keep hydraulic oil clean and to extend the service life of the hydraulic components.

14. Install under cover (2).

Wrench size: 17 mm

15. Tighten cap (1).

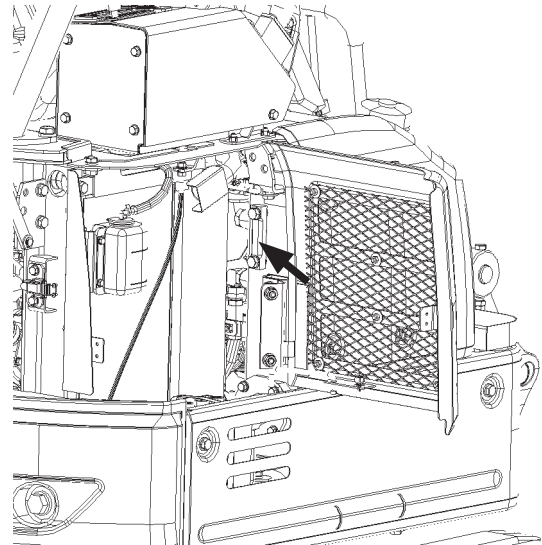

ZX17U-6, 19U-6

MABA-07-018-2 ja

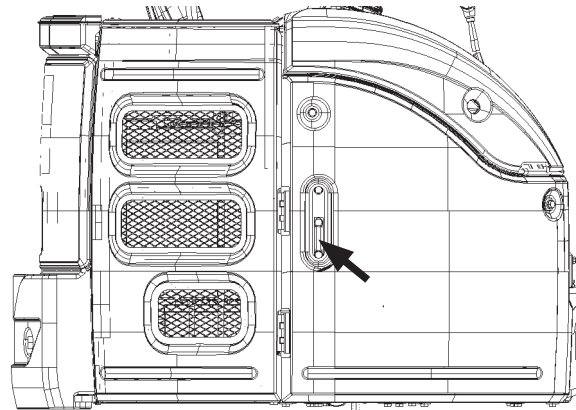

ZX26U-6

MABA-07-062-2 ja



## MAINTENANCE

### 7 Check Hoses and Lines

--- daily

--- every 250 hours

#### WARNING

- Hydraulic oil and lubricant leaks can lead to fire that may result in serious injury. Check for missing or loose clamps, kinked hoses, lines or hoses that rub against each other, damaged oil cooler, and loose oil cooler flange bolts, for leaks.
- Escaping oil under pressure can penetrate the skin, causing serious injury. To avoid this hazard, search for oil leaks with a piece of cardboard. Take care to protect hands and body from high-pressure fluids. If oil penetrates your skin, immediately get treatment from a doctor familiar with how to treat such an injury.
- Tighten, repair or replace any missing, loose or damaged clamps, hoses and lines.
- Do not bend or strike high-pressure lines.
- Never install bent or damaged hoses or lines.

Check hoses and lines for oil leaks and damage according to the check points shown below. If any abnormality is found, replace or retighten as instructed in the table.



SA-031 ja

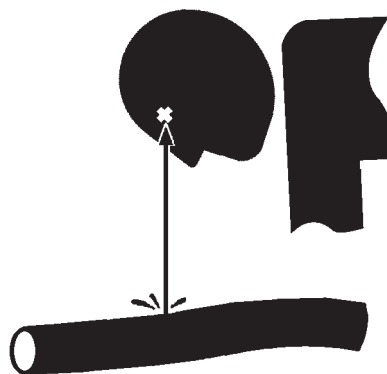

SA-292 ja



SA-044 ja

Hose

Interval (hours)	Inspection Point	Check For	Remedies
Daily	Hose covers	Leaks (1)	Replace
	Hose ends	Leaks (2)	Replace
	Fittings	Leaks (3)	Retighten or replace hose or O-ring

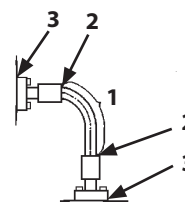

M137-07-008-3 ja

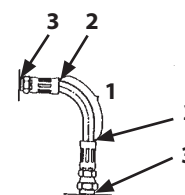

M115-07-145-3 ja

## MAINTENANCE

Interval (hours)	Inspection Point	Check For	Remedies
Every 250 hours	Hose covers	Leaks (4)	Replace
	Hose ends	Leaks (5)	Replace
	Hose covers	Exposed reinforcement (6)	Replace
	Hose covers	Cracks or blisters (7)	Replace
	Hose	Bends (8), collapse (9)	Replace
	Hose ends and fittings	Deformation or corrosion (10)	Replace

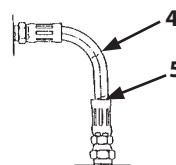

M115-07-146-3 ja

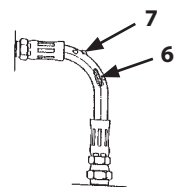

M115-07-147-3 ja

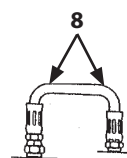

M115-07-148-3 ja

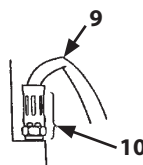

M115-07-149-3 ja

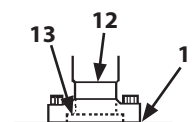

M137-07-001-3 ja

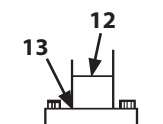

M137-07-007-3 ja

### Lines

Interval (hours)	Inspection Point	Check For	Remedies
Daily	Contact surfaces of flange joints	Leaks (11)	Replace
	Bolts	Loose or leak (11)	Retighten or replace O-ring
	Welded surfaces on flange joints	Leaks (12)	Replace
Every 250 hours	Flange joint neck	Cracks (13)	Replace
	Welded surfaces on flange joints	Cracks (12)	Replace
	Clamps	Missing, deformed or loose bolts	Replace or retighten

### Oil Cooler

Interval (hours)	Inspection Point	Check For	Remedies
Every 250 hours	Hose and Fittings	Leaks (14)	Retighten or replace
	Oil Cooler	Leaks (15)	Replace

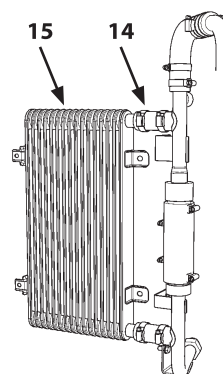

MADB-07-021-1 ja

## MAINTENANCE

### Service Recommendations for Hydraulic Fittings

- Metal Face Seal Fittings

Fittings are used on smaller diameter joints and consist of a metal flare (4) and a metal flare seat (3).

1. Inspect flare (4) and flare seat (3). They must be free of dirt or obvious defects.
2. After adjusting, tighten fitting (1) by hand.
3. Tighten fitting (1) or nut (2) to the torque values shown. Do not allow hoses to twist when tightening fittings.

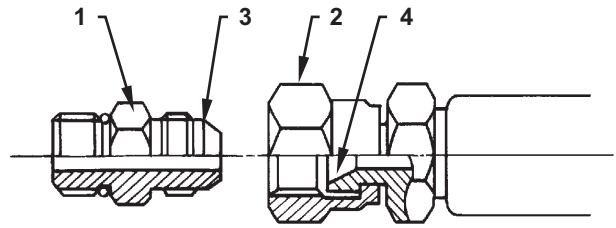

M202-07-051-3 ja

±10 %

Wrench size (mm)		17	19	22	27
Tightening Torque	N·m	25	30	40	65
	(kgf·m)	(2.5)	(3)	(4)	(6.5)

### Quick Coupler

1. Connection Procedure

- a. While pulling and fully turning socket ring (1) counterclockwise, insert socket ring (1) onto plug (3) until the end face of socket ring (1) comes in contact with plug (3).
- b. Release socket ring (1). Check that socket ring (1) is slightly moved backward by the spring force and that the coupler is held in position with balls (2). Be sure to check that socket ring (1) has been moved back fully to the right original position.

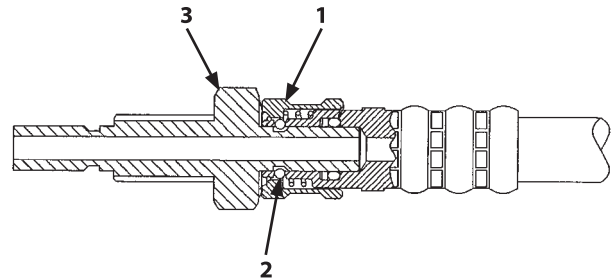

M1M7-07-006-1 ja

2. Disconnection Procedure

- a. While pulling and fully turning socket ring (1) counterclockwise, disconnect the coupler. As no check valve is provided in the coupler, take care that oil may flow out of the coupler when the coupler is disconnected.
- b. After the coupler is disconnected, plug the holes with the exclusively prepared plugs.

### IMPORTANT

- **Take care not to damage the joint surfaces when disconnecting or connecting the coupler.**
- **Before disconnecting or connecting the coupler, clean the coupler and its surroundings with a cleaning solvent and completely wipe off the cleaning solvent. Use extra care not to allow foreign matter such as dirt to enter the coupler.**
- **Disconnect or connect the coupler in the correct procedure. Confirm by inspection that no oil leak is present after connecting the coupler.**
- **After connecting the coupler, check that socket ring (1) has been moved back fully to the right original position.**

## MAINTENANCE

### Quick Coupler

#### 1. Connection Procedure

Always grasp the coupler by its crimped fitting. Push the body straight in until dust cover (1) retracts approx. 2 mm. Then, pull straight back on crimped fitting (2) to make sure the coupler is properly connected and will not disconnect.

#### **CAUTION**

**If the coupler is grasped and pushed by dust cover (1), or not pushed until the dust cover retracts, incomplete connection of the coupler may result, causing the coupler to disconnect when under pressure. Even if the coupler is not properly connected, if pulling force is applied at an angle, the coupler may be difficult to disconnect. Take care not to insert the coupler at an angle. If the coupler is forced in at an angle, it will damage internal parts and cause a leak and/or coupler failure.**

#### 2. Disconnection Procedure

Check the joint before disconnecting it. If anything is sticking to it, such as sand or dirt, clean it off with mineral oil, such as kerosene.

- Hold by crimped fitting (2) and push the body straight in about 2 mm.
- With the body pushed in, pull back on dust cover (1).
- Pull on the entire coupler as-is to disconnect it.

#### **NOTE**

*To disconnect the joint in a space too narrow to get fingers in, refer to the method described below.*

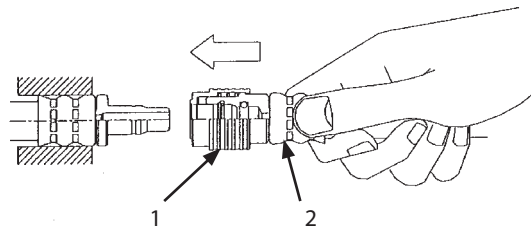

M1LA-07-014-1 ja

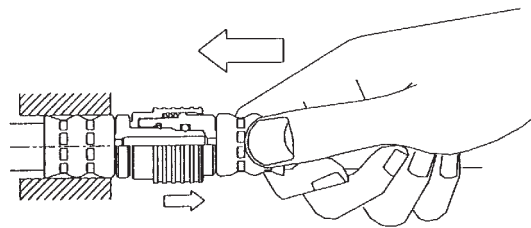

Click

M1LA-07-015 ja

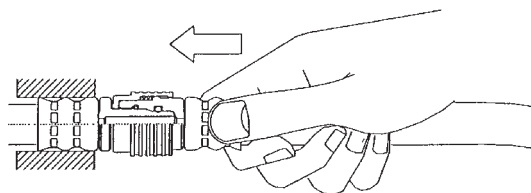

Approximately 2 mm

M1LA-07-016 ja

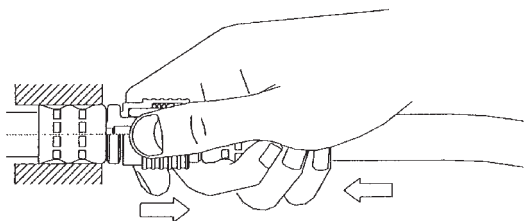

M1LA-07-017 ja

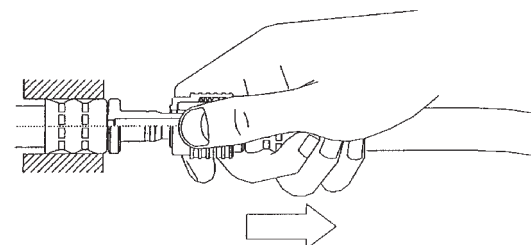

M1LA-07-018 ja

## MAINTENANCE

### Using a Screwdriver

A screwdriver with a tip thickness of less than 1 mm and a tip width of approx. 5 mm is appropriate for this job.

- a. Slightly push the hose toward the coupler approx. 2 mm.
- b. With the hose pushed in, insert a screwdriver (3) as illustrated at right and twist it about 90°. Once a gap of about 2 mm or so is created between the adapter (2) and the dust cover (1), pull back on the hose and disconnect the joint.

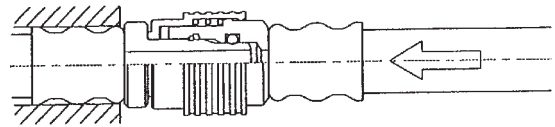

M1LA-07-021 ja

### 3. Precautions for Re-using Couplers

- a. Before connecting a coupler, be sure to check the coupler surface for any foreign matter on it. Clean off any foreign matter that is present. Any foreign matter sticking to it may cause oil leaks and/or disconnection of the coupler.
- b. When a hose needs to be clamped, put a clamp 200 mm away from the joint edge. If the hose is clamped as illustrated at right, the coupler joint may slide as oil pressure changes, causing oil leaks due to premature wear of internal parts.
- c. Do not use a coupler as a step and do not handle them roughly. Doing so may break dust cover (1), making it hard to disconnect the coupler.
- d. Do not paint on the joint surface. The body will become attached to the dust cover, making it impossible to disconnect the coupler.

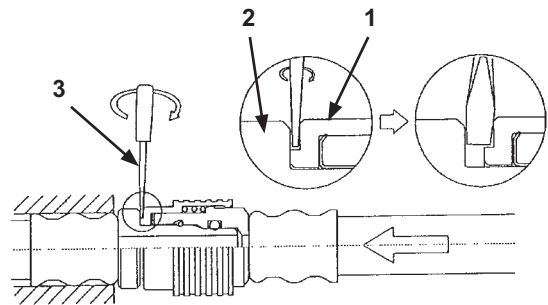

M1LA-07-022-2 ja

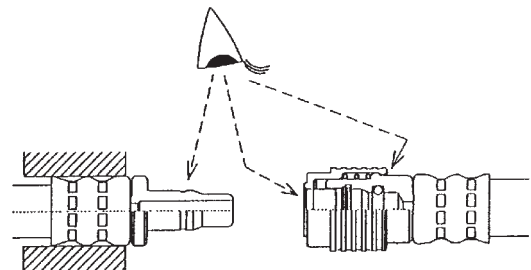

M1LA-07-019 ja

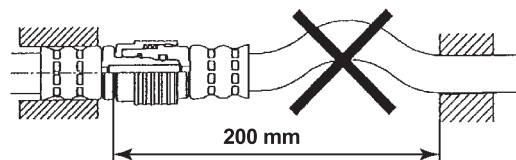

M1LA-07-020-1 ja

## MAINTENANCE

---

### E. Fuel System

 **WARNING**

**Beware of fire. Fuel is flammable. Keep fuel away from fire hazards.**

### **IMPORTANT**

**Always fill the fuel tank with the specified diesel fuel. Failure to do so may cause engine trouble and also make it difficult for the engine to start.**

### **Recommended Fuel**

Use only super high quality or high quality DIESEL FUEL (JIS K-2204) (ASTM 2-D). Kerosene must NOT be used. Besides, using bad quality fuel, drainage agent, fuel additives, gasoline, kerosene or alcohol refueled or mixed with specified fuel may deteriorate performance of fuel filters and cause sliding problem at lubricated contacts in the injector. It also affects the engine parts, leading to malfunction. Using fuel other than ultra low-sulfur or low-sulfur diesel fuel has adverse effects on the engine, which may result in malfunction.

# MAINTENANCE

## 1 Check Fuel Level

--- every 8 hours

### **CAUTION**

Handle fuel carefully. Stop the engine before refueling. Keep flame away from the area when refueling or working on the fuel system.

1. Park the machine according to the instructions of (7-6) Preparations for Inspection and Maintenance.

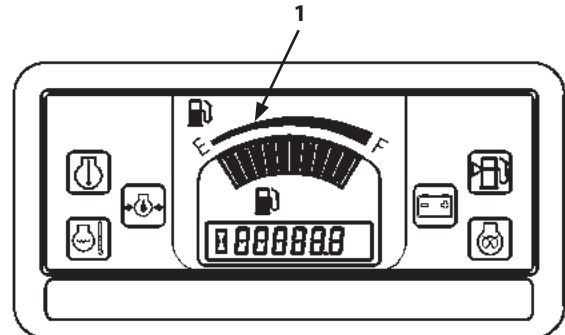

M1NC-01-005-6 ja

2. Check the fuel level gauge (3) (ZX26U-6) and fuel gauge (1) on the monitor. If the fuel level is low, stop the engine. Refuel by removing cap (2) on the fuel tank.

### **IMPORTANT**

Keep all dirt, dust, water and other foreign materials out of the fuel system when refilling fuel.

### **NOTE**

ZX26U-6

Even if all segments on the fuel gauge (1) show as full, there are cases where the tank may not be completely full. Check the fuel level in conjunction with fuel level gauge (3).

3. To avoid condensation, fill the tank at the end of each day's operation. Take care not to spill fuel on the machine or ground.

Model	Tank Capacity
ZX17U-6, 19U-6	20 L
ZX26U-6	32 L

4. After refilling fuel, install cap (2). Close tank cover (4) and be sure to lock it to prevent vandalism.

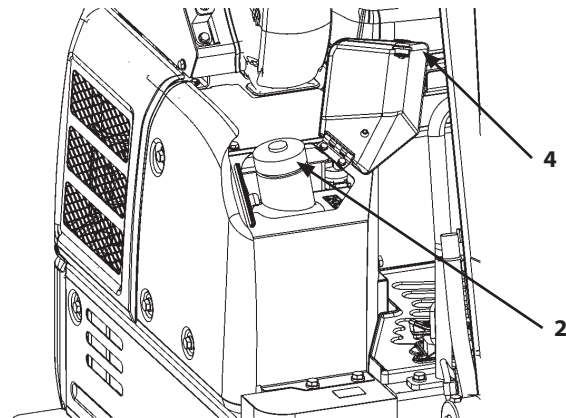

ZX17U-6, 19U-6

MABA-07-007-1 ja

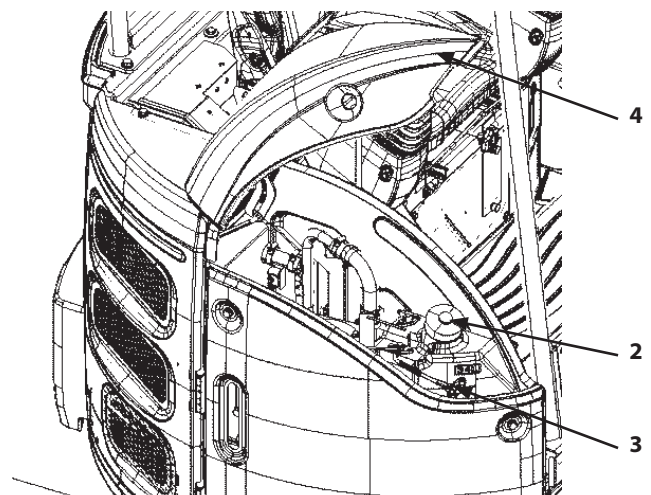

ZX26U-6

MABK-07-009-2 ja

## MAINTENANCE

### 2 Check Water Separator

#### Drain water --- check daily (before starting work)

Water separator (1) is a device designed to separate water from the fuel. There is a float inside the case that floats when water accumulates.

Drain the separator when the float rises up to the "Drain Level."

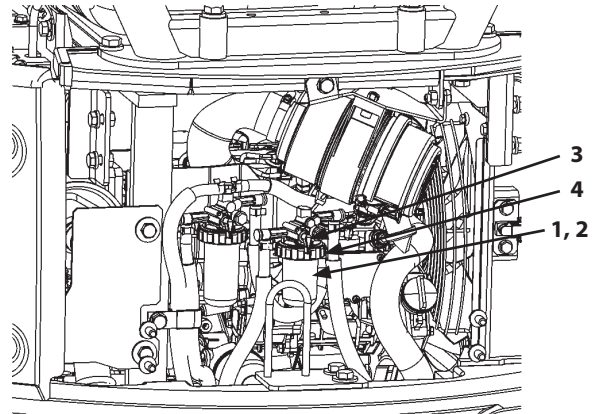

ZX17U-6, 19U-6

MABA-07-049-1 ja

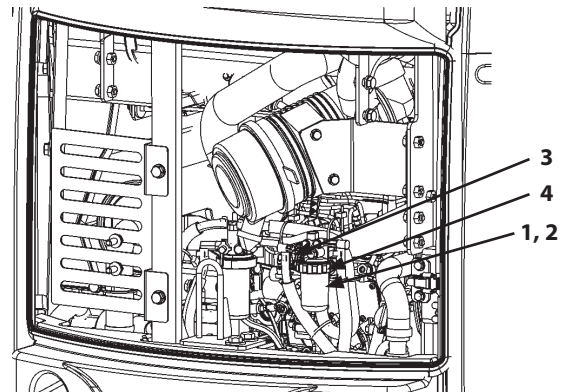

ZX26U-6

MABA-07-050-1 ja

#### Drain Procedure

1. Park the machine according to the instructions of (7-6) Preparations for Inspection and Maintenance.
2. Place a 0.5 liter or larger container under water separator (1).
3. Close cock (3).
4. Loosen ring nut (4) of water separator (1) and then remove filter cap (2) to drain off water.
5. While it is draining, clean fuel cap (2) and the filter. After cleaning them, tighten ring nut (4) securely on water separator (1).
6. Open fuel cock (3).

#### IMPORTANT

**After draining water mixed into the fuel, bleed air from the fuel supply system.**



## MAINTENANCE

---

### **Bleeding Air from the Fuel System**

Air in the fuel system may make the engine hard to start or make it run irregularly.

Bleed air from the fuel system if the fuel tank is run dry or after replacing the fuel filter element.

This machine is equipped with an automatic air bleeding device.

1. Check whether the fuel tank is half full or not. If it is low, add fuel.
2. Turn the key switch to the ON position and hold in that position for 10 to 15 seconds.
3. Start the engine. Check the fuel supply system for fuel leaks.

## MAINTENANCE

### 3 Drain Fuel Tank Sump

#### --- As required

1. Park the machine according to the instructions of (7-6) Preparations for Inspection and Maintenance.
2. Loosen bolts (2) of right cover (1) and remove it.
3. Place a 0.5 liter or larger container under drain hose (3).
4. Open drain valve (3) and drain water and sediment.
5. After draining water, securely tighten drain plug (3).
6. Secure right cover (1) with bolts (2) .

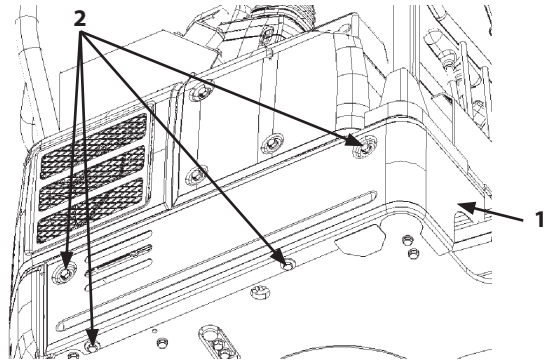

ZX17U-6, 19U-6

MABA-07-051-1 ja

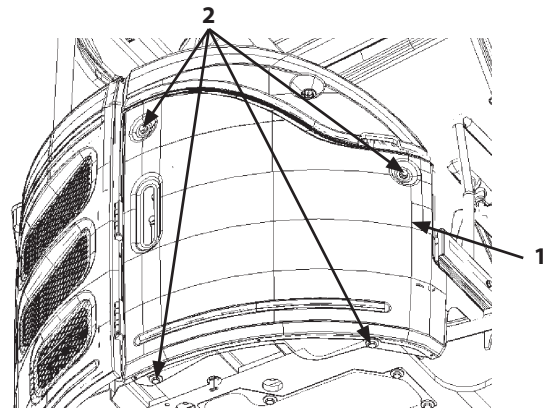

ZX26U-6

MABA-07-052-1 ja

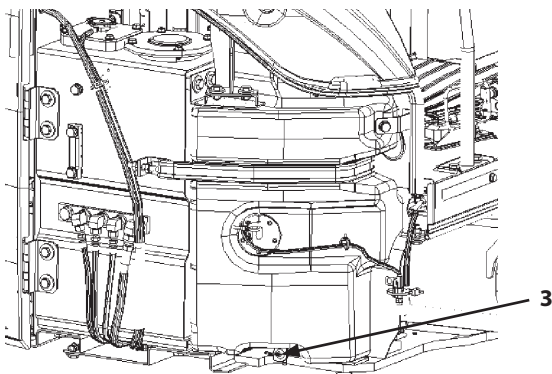

ZX26U-6

MABA-07-054-1 ja

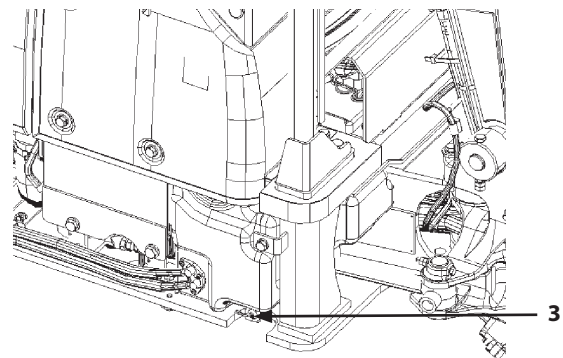

ZX17U-6, 19U-6

MABA-07-053-1 ja

# MAINTENANCE

## 4 Replace Fuel Main Filter Element

--- every 500 hours

### IMPORTANT

- Be sure to use only genuine Hitachi elements for the fuel main filter element. Failure to do so may deteriorate the engine performance and/or shorten the engine service life. Please note that any engine failure caused by using an element of another manufacture is excluded from the Hitachi Warranty Policy.
- Take care not to allow dirt and/or water to enter the fuel tank.

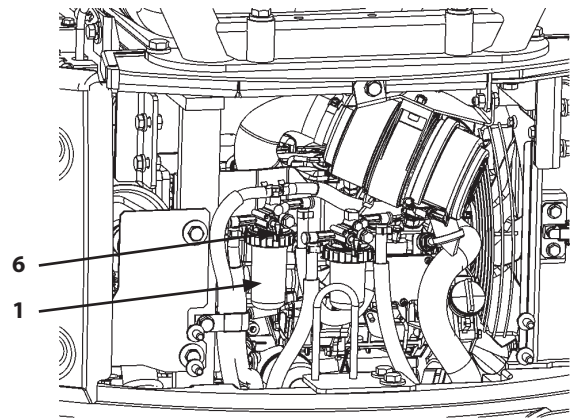

ZX17U-6, 19U-6

MABA-07-049-2 ja

1. Park the machine according to the instructions of (7-6) Preparations for Inspection and Maintenance.
2. Close cock (6).
3. Place a 0.5 liter or larger container under fuel main filter (1).
4. Loosen ring nut (3) of fuel filter (1) and then remove filter cap (4).
5. Replace element (2) at this point.
6. During installation, clean filter cap (4), install the new element (2) and tighten ring nut (3) securely.
7. Open fuel cock (6).
8. Loosen air bleed plug (5) and if fuel comes out, tighten it again.
9. Bleed Air from Fuel System  
After replacing the fuel filter element, bleed air from the fuel supply system.  
(Refer to (7-61) Bleeding Air from the Fuel System in 2.)

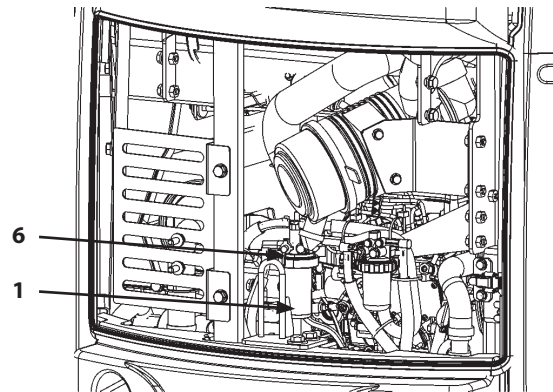

ZX26U-6

MABA-07-050-2 ja

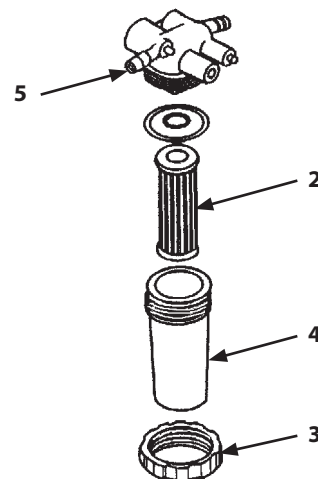

M503-07-038-2 ja

## MAINTENANCE

### 5 Check Fuel Hoses

--- daily

--- every 250 hours

#### **WARNING**

Fuel leaks can lead to fires that may result in serious injury.

- Check for twisted or kinked hoses, hoses that rub against each other or other parts and any fuel leaks.
- Repair or replace any loose or damaged hoses.
- Never reinstall bent or damaged hoses.

Check hoses for oil leaks and damage according to the check points shown below. If any abnormality is found, replace or retighten as instructed in the table.

Hose

Interval (hours)	Inspection Point	Check For	Remedies
Daily	Hose ends	Leaks (1)	Retighten or replace
	Hose covers	Wear, cracks (2)	Replace
Every 250 hours	Hose covers	Cracks (3)	Replace
	Hose ends	Cracks (4)	Replace
	Hose	Bends (5), Collapse (6)	Replace
	Hose fittings	Corrosion (7)	Replace

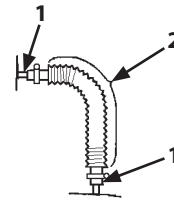

M137-07-003-1 ja

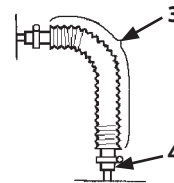

M137-07-004-1 ja

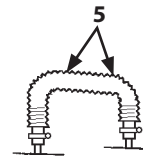

M137-07-005-1 ja

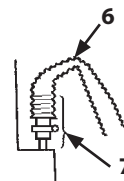

M137-07-006-1 ja

# MAINTENANCE

## F. Air Cleaner

### 1 Clean and Replace Air Cleaner Element

**Clean --- every 250 hours**

**Replace --- after cleaning 6 times or after one year**

1. Stop the engine before servicing element (1).
2. Release the two clamps (2) on cover (3) to remove element (1).
3. Remove outer element (1).

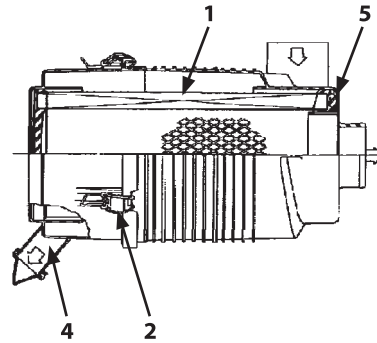

M555-07-023-1 ja

4. Tap outer element (1) with the palm of your hand. Do not hit on a hard surface.

### **⚠ WARNING**

**When using compressed air pressure (no higher than 0.69 MPa (7 kgf/cm<sup>2</sup>), wear safety glasses or goggles.**

### **IMPORTANT**

**When cleaning do not hit or strike outer element (1) against another object.**

5. Clean element (1) by blowing compressed air [less than 0.69 MPa (7 kgf/cm<sup>2</sup>)] from the inside of the element. After cleaning is complete, be sure to check outer element (1) for any damage and if any damage is found, replace the element with a new one.
6. When installing cover (3), position the cover so that valve (4) faces downward. Then, tighten the cover with clamps (2) in the specified position.

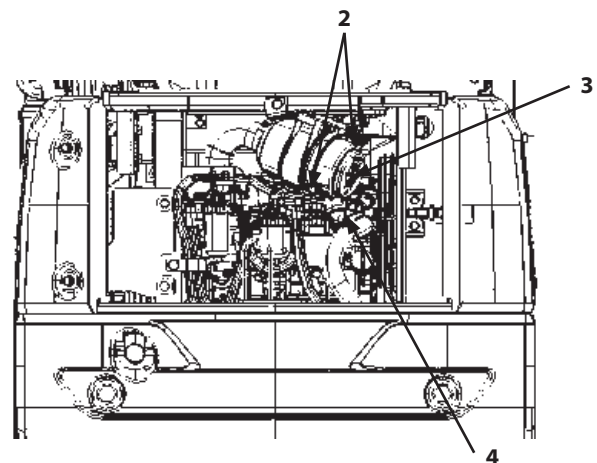

ZX17U-6, 19U-6

MABA-07-033-1 ja

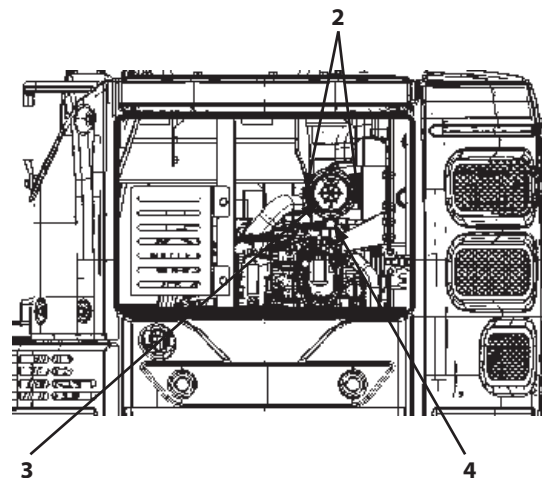

ZX26U-6

MABA-07-034-1 ja

## MAINTENANCE

---

### G. Cooling System

#### Coolant

#### IMPORTANT

Use fresh water or normal tap water as a coolant. Do not use strong acid or alkaline water. Use a coolant mixed with genuine Hitachi Long-Life Coolant (LLC) at a concentration of 30 to 50 %.

If a coolant mixed with less than 30 % of Hitachi Long-Life Coolant (LLC) is used, the service life of the cooling parts may be shortened due to damage by freezing or corrosion of coolant system parts.

If it is above 60 %, the engine may overheat.

#### Antifreeze Mixing Ratio

Antifreeze Ratio (%)	30	35	40	45	50
Air Temperature [°C]	-10	-15	-20	-25	-30

#### CAUTION

##### Precautions for handling antifreeze

- Antifreeze is poisonous.
- If ingested, it can cause serious injury or death. Induce vomiting and get emergency medical attention immediately.
- If antifreeze is accidentally splashed into the eyes, thoroughly flush with water and get emergency medical attention.
- When storing antifreeze, be sure to keep it in a clearly marked container with a tight lid. Always keep antifreeze out of the reach of children.
- Pay attention to fire hazards. Antifreeze is specified as a dangerous substance in the fire protection law (Class 4, Petroleum type 3).
- When disposing of antifreeze, be sure to comply with all local regulations. When storing or disposing of antifreeze, be sure to comply with all local regulations.

# MAINTENANCE

## 1 Check Coolant Level

### --- daily

With the engine cold, the coolant level must be between the FULL and LOW marks on coolant reservoir (2).

If the coolant level is below the low mark, remove the cap of coolant reservoir (1) and add to it.

### **!** WARNING

**Do not remove cap (1) until the coolant temperature in the radiator becomes cool. Hot steam may spout out, possibly causing severe burns. After the coolant temperature has lowered, slowly loosen cap (1) to release the air pressure inside before removing cap.**

If coolant reservoir (2) is empty, add coolant through cap (1) of the radiator. With ZX17U-6 or 19U-6, it is necessary to remove bolt (3) and then remove cover (4).

- When refilling a Long-Life Coolant (LLC), use the same brand product and the same mixture ratio as already used in the machine.
- If only water is refilled, the mixture ratio in the Long-Life Coolant (LLC) is diluted so that the anti-rust and antifreeze effects of the coolant deteriorate.

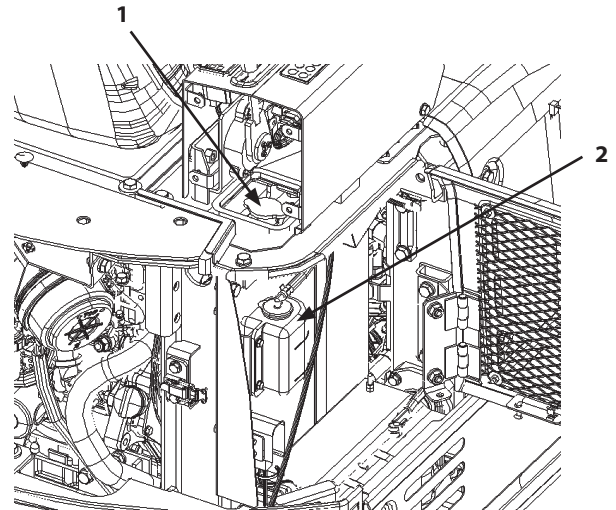

ZX17U-6, 19U-6

MABA-07-036-1 ja

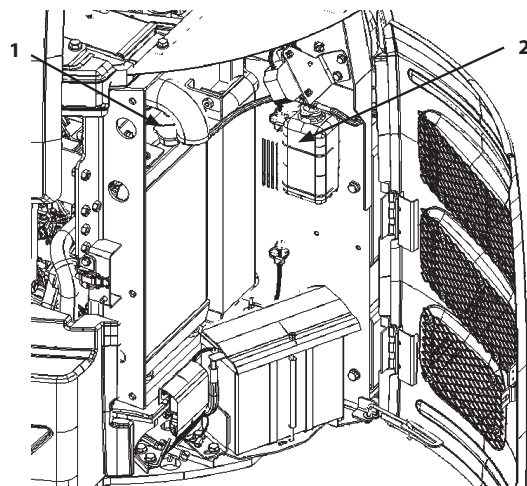

ZX26U-6

MABA-07-013-2 ja

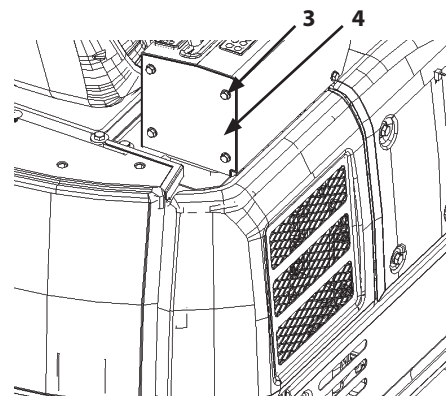

ZX17U-6, 19U-6

MABA-07-035-2 ja

## MAINTENANCE

---

### 2 Check and Adjust Fan Belt Tension

--- every 100 hours (first time only, after 50 hours)

#### IMPORTANT

**A loose fan belt may result in insufficient battery charging, engine overheating, as well as rapid, abnormal belt wear. Belts that are too tight, can damage both bearings and belts.**

#### Inspect

Check belt tension by pressing down in the middle with your thumb at a force of approximately 98 N (10 kgf). Deflection must be within the value illustrated at right.

Deflection (B): 7 to 9 mm

(Between fan pulley (1) and alternator pulley (2))

Visually check the belt for wear. Replace if necessary.

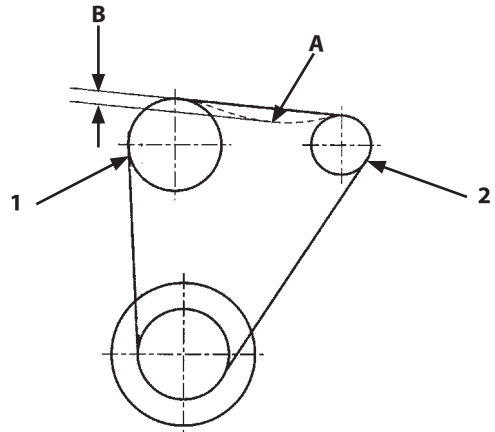

M589-07-014-2 ja



## MAINTENANCE

### Adjust Fan Belt Tension

ZX17U-6, 19U-6

1. Remove the four bolts (4) and two knobs (8) under the seat and then remove cover (3) and open the inspection window.
2. Loosen adjusting bolt (6) and mounting bolt (7) of alternator (5).
3. Adjust belt tension by moving alternator (5) forward or backward.
4. Securely tighten bolts (6) and (7).

### IMPORTANT

**When a new belt is installed, be sure to re-adjust the tension after operating the engine for about 3 to 5 minutes at slow idle speed to be sure that the new belt is seated correctly.**

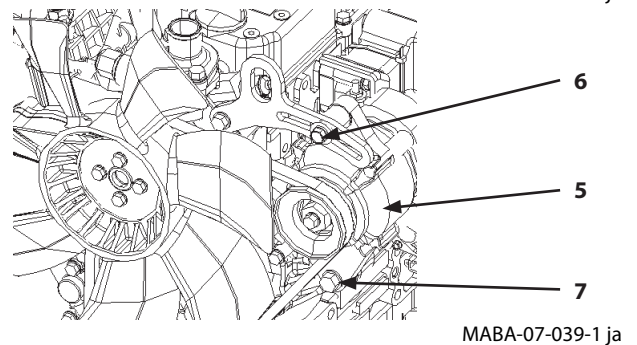
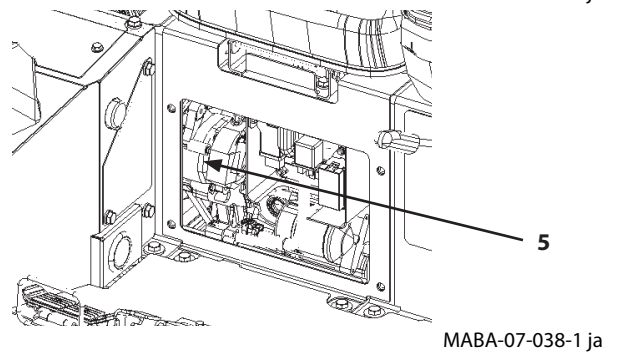
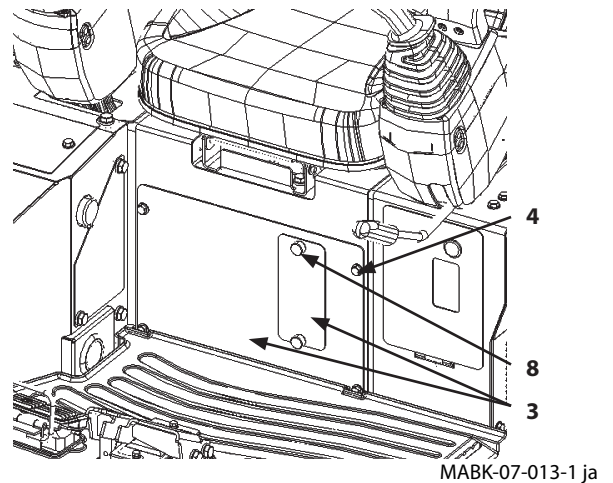

## MAINTENANCE

### ZX26U-6

1. Remove the three bolts (9) at the bottom, right of the seat and then remove cover (10). Then remove the four bolts (11), remove cover (12) and open the inspection window.
2. Loosen adjusting bolt (14) and mounting bolt (15) of alternator (13).
3. Adjust belt tension by moving alternator (13) forward or backward.
4. Securely tighten bolts (14) and (15).

### IMPORTANT

**When a new belt is installed, be sure to re-adjust the tension after operating the engine for about 3 to 5 minutes at slow idle speed to be sure that the new belt is seated correctly.**

#### NOTE

*Four bolts (9) are used for ZX26U-6 cab equipped machine.*

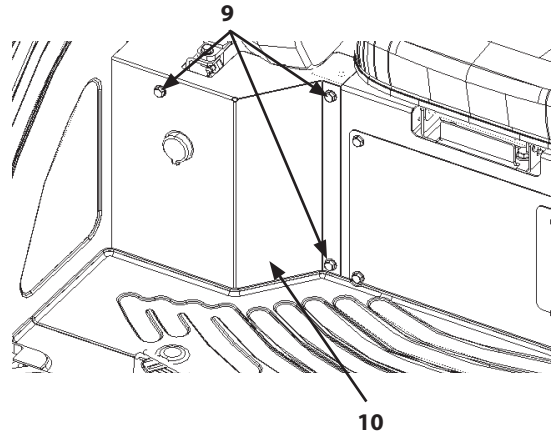

MABA-07-040-1 ja

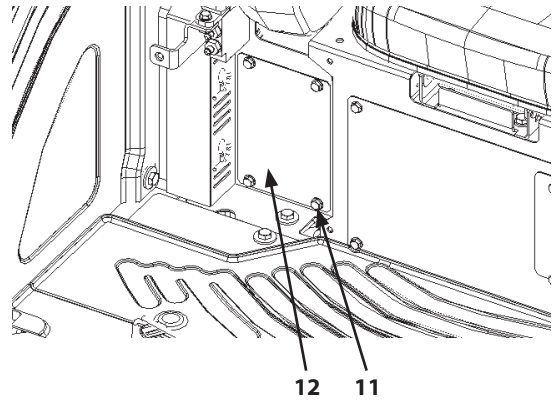

MABA-07-041-1 ja

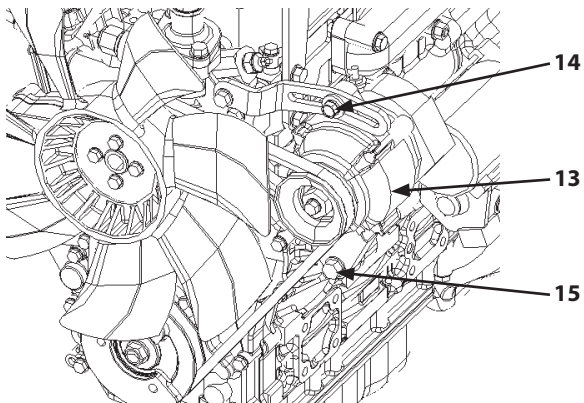

MABA-07-043-1 ja

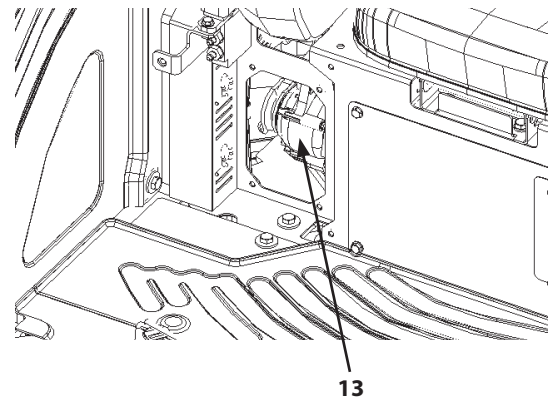

MABA-07-042-1 ja

## MAINTENANCE

### 3 Change Coolant

--- twice a year (in spring and autumn)

#### NOTE

When genuine Hitachi Long-Life Coolant (LCC) is used, the change interval is once every two years (in autumn every other year) or every 2,000 hours, whichever comes first.

#### WARNING

Do not remove cap (1) until the coolant temperature in the radiator becomes cool. Hot steam may spout out, possibly causing severe burns. Loosen the cap slowly to the stop. Release all pressure before removing the cap.

#### IMPORTANT

Use soft water as a coolant. Do not use strong acid or alkaline water. Use a coolant mixed with genuine Hitachi Long-Life Coolant (LLC) at a concentration of 30 to 50 %.

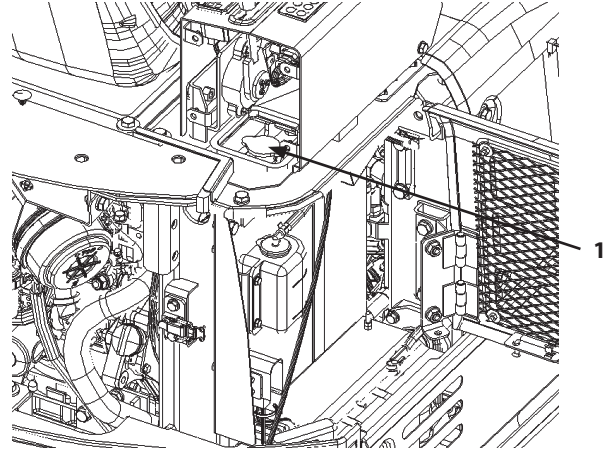

ZX17U-6, 19U-6

MABA-07-036-2 ja

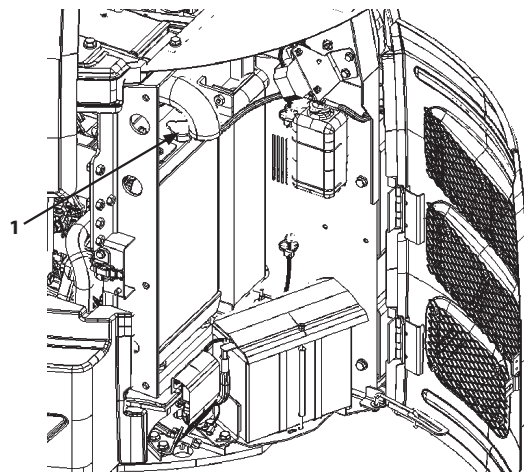

ZX26U-6

MABA-07-013-3 ja

# MAINTENANCE

## Coolant Changing Procedures

1. Park the machine according to the instructions of (7-6) Preparations for Inspection and Maintenance.
2. With a ZX17U-6 or 19U-6, remove the under cover. Remove radiator cap (1). Open drain cock (2) on the radiator and the drain cock on the water jacket to allow the coolant to drain completely. Remove impurities such as scale at the same time.
3. Close drain cock (2) and the drain cock on the water jacket. Fill the radiator with soft water containing fewer impurities or tap water and a radiator cleaner agent. Run the engine at a speed slightly higher than slow idle to raise the coolant temperature until the first two segments come on. Then, run the engine further for about 10 minutes.
4. Stop the engine and open radiator drain cock (2). Flush out the cooling system with tap water until the water coming out is clear; this helps remove rust and sediment.
5. Close drain cock (2) and fill with soft or tap water with few impurities and this time mix in LLC at the specified ratio. When adding coolant, do so slowly to avoid mixing air bubbles into the system. Run the engine to sufficiently bleed air from the cooling system.
6. After adding coolant, operate the engine for several minutes. Check the coolant level again, and add coolant if necessary.

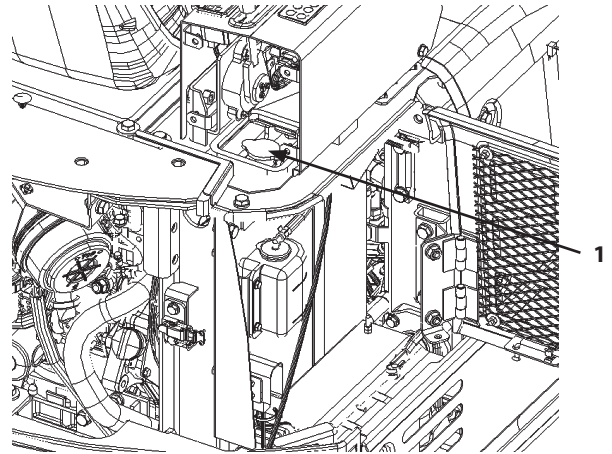

ZX17U-6, 19U-6

MABA-07-036-2 ja

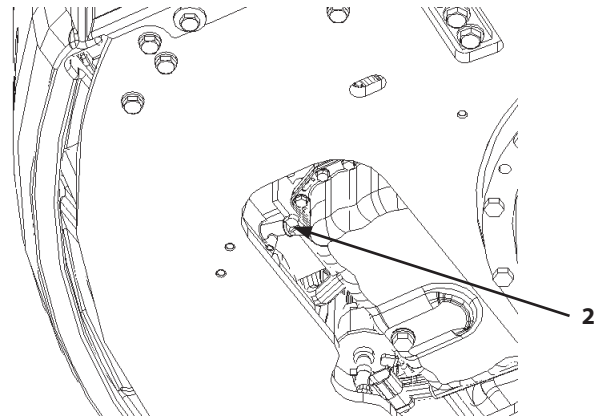

ZX17U-6, 19U-6

MABA-07-044-1 ja

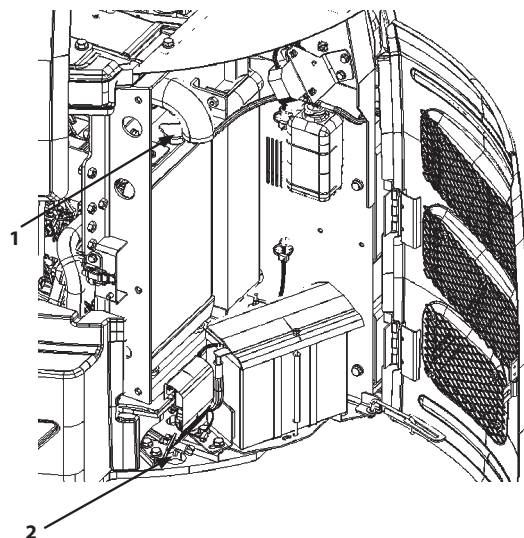

ZX26U-6

MABA-07-013-4 ja

## MAINTENANCE

---

### 4 Clean Radiator/Oil Cooler Core

Outside --- every 500 hours

Inside --- when coolant is changed

#### WARNING

- When using compressed air pressure (no higher than 0.2 MPa (2 kgf/cm<sup>2</sup>)), wear safety glasses or goggles.
- Touching moving parts is hazardous. Getting cut or entangled can lead to serious injury or death.
- Before servicing, stop the engine and the fan to prevent any accident.
- Never attempt to start the engine when the cover is open.
- If tools or parts are dropped into the radiator/oil cooler/inter cooler core, remove them before starting the engine.

#### IMPORTANT

- Clean the cover to prevent dirt or water from entering the air cleaner suction port.
- If air at a pressure of higher than 0.2 MPa (2 kgf/cm<sup>2</sup>) or tap water at high pressure is used for cleaning, it may damage the radiator fins. Keep the nozzle at least 500 mm away from the core surface.
- When the machine is operated in dusty areas, check the cores periodically and replace if necessary.

The radiator and oil cooler are arranged in parallel.

If dirt or dust is accumulated on them, cooling system performance decreases. Clean the radiator/oil cooler cores with compressed air or tap water. Also clean the oil cooler side at this time. This prevents a drop in performance of the cooling system.

## MAINTENANCE

---

### H. Electrical System

#### IMPORTANT

- **Improper radio communication equipment and associated parts, and/or improper installation of radio communication equipment affects the machine's electronic parts, causing unintended movement of the machine. Improper installation of electrical equipment may cause machine failure and/or a fire on the machine. Consult your authorized dealer when installing radio communication equipment or additional electrical parts.**
- **Never attempt to disassemble or modify the electrical/electronic components. If replacement or modification of electric or electrical components is required, contact your authorized dealer.**



SA-032 ja

## MAINTENANCE

### 1 Battery

#### WARNING

- Gas produced by the battery can be explosive. Keep sparks and flames away from batteries.
- Do not leave cover (1) removed. Do not keep tools, metals or flammable materials around the battery or inside the battery room. If a metal tool is placed across the battery terminal and a vehicle component such as the engine block, sparks may be created, possibly resulting in fire and/or explosion.
- Use a flashlight to check the battery electrolyte level.
- Do not continue to use or charge the battery when electrolyte level is lower than specified. Explosion of the battery may result.
- Sulfuric acid is used in the battery electrolyte. It is strong enough to burn skin and eat holes in clothing. It can cause blindness if splashed into the eyes.

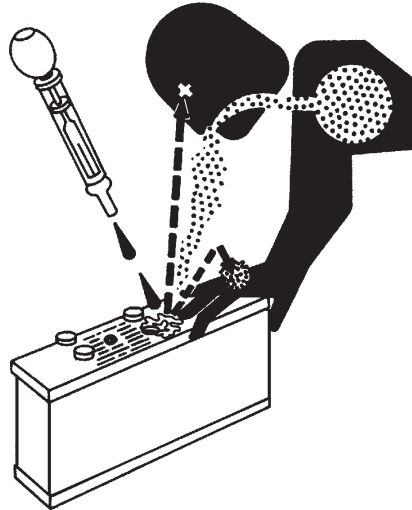

SA-036 ja

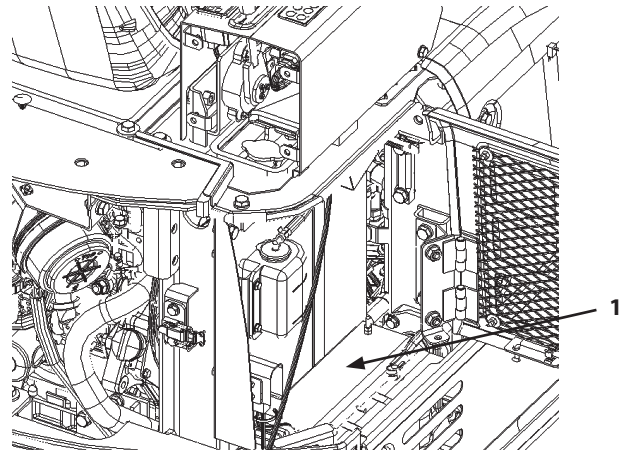

ZX17U-6, 19U-6 Battery Location

MABA-07-036-3 ja

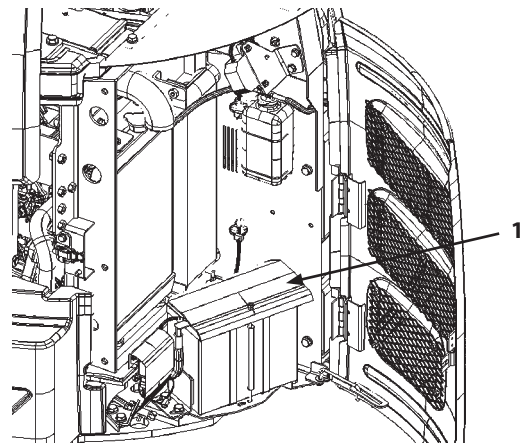

ZX26U-6 Battery Location

MABA-07-013-6 ja

## MAINTENANCE

---

### Avoid hazard by:

1. **Charging the batteries in a well ventilated location.**
2. **Wearing eye protection and rubber gloves.**
3. **Avoiding breathing fumes when electrolyte is added.**
4. **Avoiding spilling or dripping electrolyte.**
5. **Using proper booster battery starting procedures.**

### If you spill acid on yourself:

1. **Flush your skin with water.**
2. **Apply baking soda or lime to help neutralize the acid.**
3. **If it gets in your eyes, rinse them out for 15 to 30 minutes and get medical attention immediately.**

### If acid is swallowed:

1. **Do not induce vomiting.**
2. **Drink large amounts of water or milk.**
3. **Get medical attention immediately.**

### IMPORTANT

- **Add water to batteries in freezing weather before you begin operating your machine for the day, or before charging the batteries.**
- **If the battery is used with the electrolyte level lower than the specified lower level, the battery may deteriorate quickly.**
- **Do not refill electrolyte above the specified upper level. Electrolyte may spill, damaging the painted surfaces and/or corroding other machine parts.**

### NOTE

*If electrolyte is refilled above the specified upper level line or beyond the bottom end of the sleeve, use a pipette to remove the excess electrolyte until the electrolyte level is down to the bottom end of the sleeve. After neutralizing the wiped up electrolyte with sodium bicarbonate, flush it with plenty of water. Or, consult the battery manufacturer.*



## MAINTENANCE

### Electrolyte Level Check --- every month

Check the electrolyte level at least once a month.

1. Park the machine on level ground and stop the engine.
2. How to Check the Electrolyte Level
  - a. To check the level from the side of the battery: Clean around the level marks with a water-dampened cloth and make sure the electrolyte level is between U.L (Upper Level) and L.L (Lower Level). Do not use a dry towel. Static electricity may develop, causing the battery gas to explode.  
If the electrolyte level is lower than the middle level between the U.L and L.L, immediately refill with distilled water or commercial battery fluid. After refilling, securely tighten the filler plug. Be sure to refill with distilled water before charging (operating the machine).

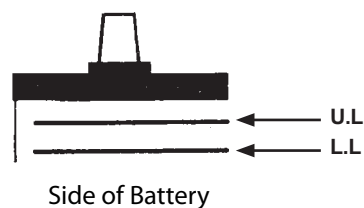

M146-07-109-2 ja

U.L Upper Level

L.L Lower Level

- b. If checking from the side of the battery is not possible, or if there are no level marks on the side:

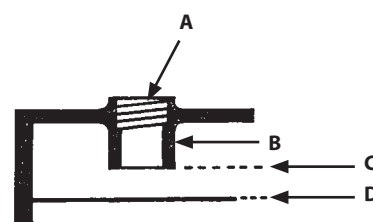

M146-07-110-2 ja

A Filler plug  
B Sleeve

C Upper Level  
D Lower Level (Separator Top)

After removing the filler plug from the top of the battery, check the electrolyte level by viewing through the filler port. It is difficult to judge the electrolyte level accurately in this case, so judge its level as illustrated. When the electrolyte level is lower than the bottom end of the sleeve, refill with distilled water or commercial battery fluid up to the bottom end of the sleeve. After refilling, securely tighten the filler plug. Be sure to refill with distilled water before charging (operating the machine).

- c. If the level can be checked with an indicator, etc., follow its instructions.

### Checking the Level via an Indicator

Good



When electrolyte reaches the bottom of the sleeve, surface tension makes the electrodes appear bent.

Low



When the electrolyte surface is lower than the bottom end of the sleeve, the electrode ends appear straight.

## MAINTENANCE

---

3. Always keep the area around the battery terminals clean. This prevents the battery from discharging. Check terminals for looseness and/or rust. Coat terminals with grease or petroleum jelly to prevent corrosion build up.

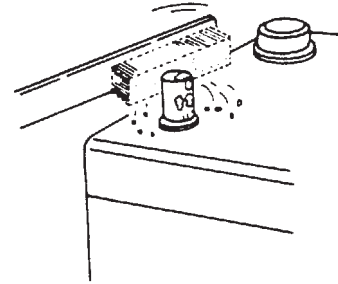

M409-07-072 ja

### Check Electrolyte Specific Gravity---every month

#### **WARNING**

- **Battery gas can explode. Keep sparks and flames away from batteries. Use a flashlight to check the battery electrolyte level.**
- **Sulfuric acid in battery electrolyte is poisonous. It is strong enough to burn skin, eat holes in clothing, and cause blindness if splashed into the eyes.**
- **Never check the battery charge by placing a metal object across the posts. Use a voltmeter or hydrometer.**

#### **Avoid hazards by:**

1. **Charging the batteries in a well-ventilated location.**
2. **Wearing eye protection and rubber gloves.**
3. **Avoiding breathing the fumes when electrolyte is added.**
4. **Avoiding spilling or dripping electrolyte.**
5. **Using proper booster battery starting procedures.**

#### **If you spill acid on yourself:**

1. **Flush your skin with water.**
2. **Apply baking soda or lime to help neutralize the acid.**
3. **If it gets in your eyes, rinse them out for 15 to 30 minutes and get medical attention immediately.**

#### **If acid is swallowed:**

1. **Do not induce vomiting.**
2. **Drink large amounts of water or milk.**
3. **Get medical attention immediately.**

## MAINTENANCE

### IMPORTANT

**Allow the battery to cool down before testing the specific gravity of the electrolyte, not immediately after operating the machine.**

Check the electrolyte specific gravity in each battery cell.

The lower limit of the specific gravity varies with electrolyte temperature. The specific gravity should be kept within the range (A) shown below. Charge the battery if the specific gravity is below the limit.

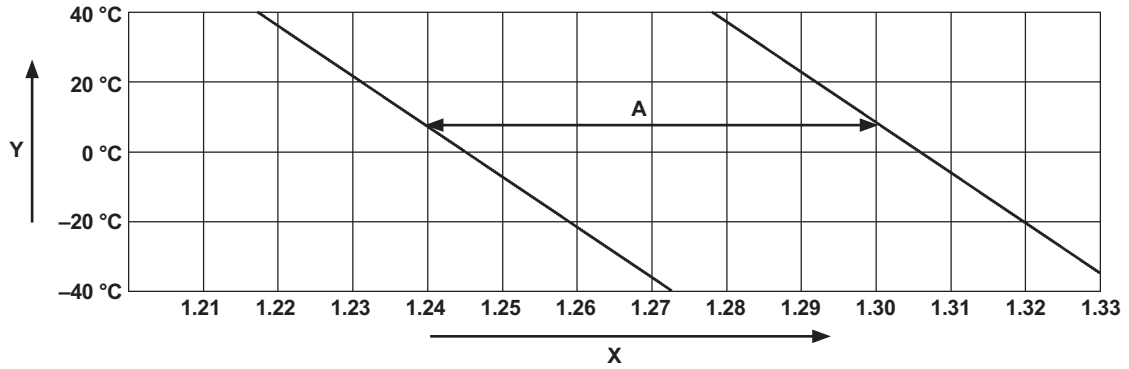

MADR-07-005-1 ja

X: Specific gravity of battery fluid

Y: Fluid temp.

# MAINTENANCE

## 2 Replacement of Fuses

If any electrical equipment fails to operate, first check the fuses in the fuse box.

### IMPORTANT

**Install a fuse with the correct amperage rating to prevent electrical system damage from overload.**

ZX17U-6,19U-6

5 A	START	5 A	HORN, MONITOR B
10 A	OPTIONS, ALARM	10 A	LIGHT
5 A	ENGINE	5 A	MONITOR ACC
10 A	PILOT SHUT OFF, TRAVEL, ILLUMINATION	5 A	MONITOR GLOW
		20 A	POWER SOCKET

ZX26U-6

5 A	START	5 A	HORN, MONITOR B, RADIO, OPTION POWER
10 A	OPTION, RADIO ACC, OPTION POW- ER ACC	20 A	LIGHTS, CAB POW- ER SOCKET
10 A	ENGINE	5 A	MONITOR ACC
5 A	PILOT SHUT OFF, TRAVEL, ILLUMINA- TION	5 A	MONITOR GLOW
		20 A	POWER SOCKET

### NOTE







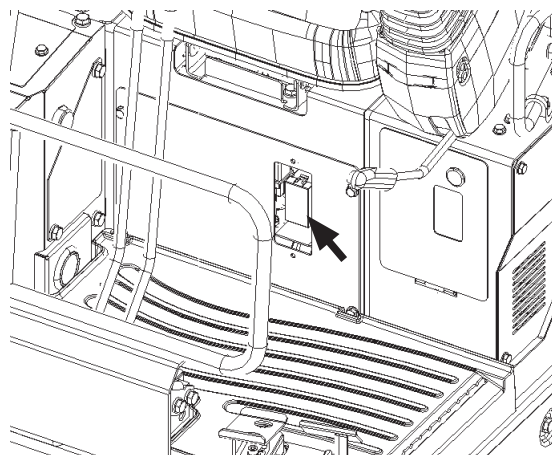



One spare fuse for each fuse capacity is provided in the fuse box.

ZX26U-6 (Cab equipped machine)

1	30 A	HEATER
2	10 A	WIPER, WASHER, ROOM LAMP













MABA-07-045-1 ja

		5 A	START	5 A	HORN, MONITOR B
		10 A	OPTION, ALARM	10 A	LIGHT
		5 A	ENGINE	5 A	MONITOR ACC
		10 A	PILOT SHUT OFF, TRAVEL, ILLUMI.	5 A	MONITOR GLOW
				20 A	POWER SOCKET

YD00008579

ZX17U-6,19U-6

MABA-07-046 ja

		5 A	START	5 A	HORN, MONITOR B, RADIO, OPT. POWER
		10 A	OPT. RADIO ACC, OPT. POWER ACC	20 A	LIGHT, CAB SOCKET
		5 A	ENGINE	5 A	MONITOR ACC
		5 A	PILOT SHUT OFF, TRAVEL, ILLUMI.	5 A	MONITOR GLOW
				20 A	POWER SOCKET

YD00006351

ZX26U-6

MABA-07-059 ja

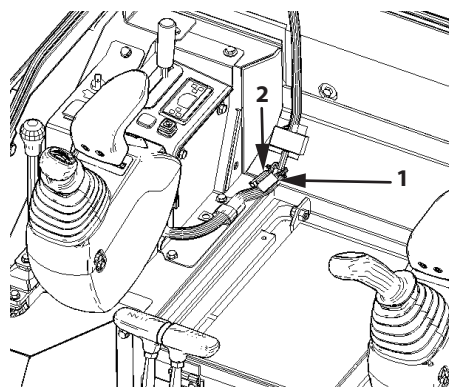

MABK-07-017-1 ja

# MAINTENANCE

## I. Miscellaneous

### 1 Check and Replace Bucket Teeth

--- daily

Check bucket teeth (1) for wear and looseness.  
Replace if wear is beyond the service limit in the table.

	New	Service Limit
A (mm)	128	65

#### CAUTION

- **Guard against injury from flying pieces of metal. Wear hard hat or safety glasses, and safety equipment appropriate to the job.**

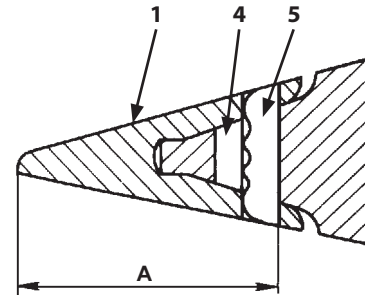

M104-07-056-1 ja

#### Replace

1. Use hammer (2) and drift (3) to drive out lock pin (5). Take care not to damage lock rubber (4).
2. Inspect the lock pin (5) and lock rubber (4) after removing them. As shown in the diagram, short lock pins (5) and damaged lock rubber (4) must be replaced with new ones.

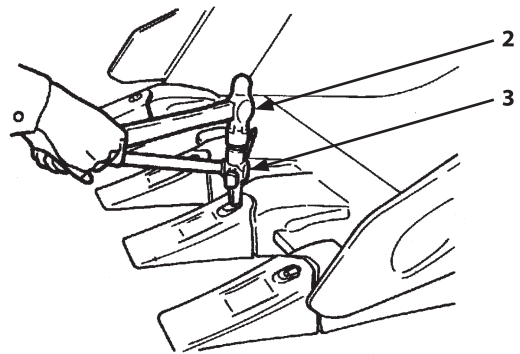

M589-07-017-1 ja

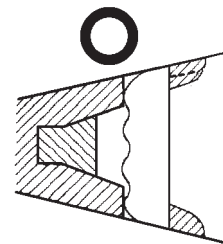

M104-07-118-2 ja

## MAINTENANCE

### Examples of Defective Lock Pins (5) and Lock Rubbers (4)

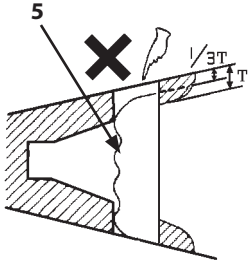
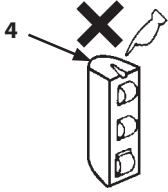
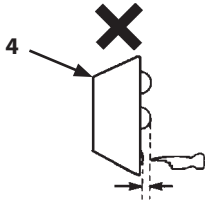
		
Lock pin (5) is too short	Steel ball may come out from the cracked rubber	Pressing on the protruding steel ball makes it sink in.

3. Clean shank (6) surface.

4. Install lock rubber (4) into shank (6) hole as shown.

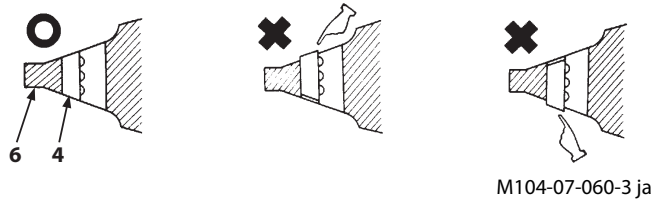

5. Position new tooth (1) over shank (6).

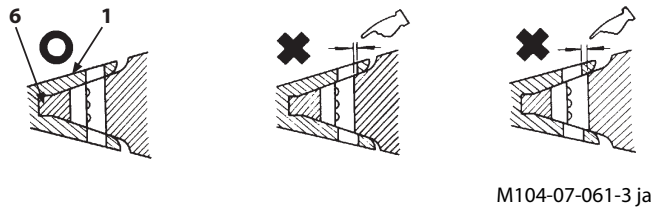

6. Drive lock pin (5) in so it is flush with the surface of tooth (1).

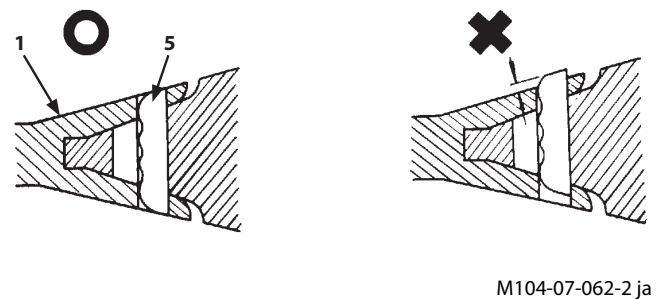

## MAINTENANCE

### 2 Change Bucket

--- as required

#### CAUTION

**When removing/mounting pins, be careful of flying pieces of metal to avoid injury. Wear hard hat or safety glasses, and safety equipment appropriate to the job.**

Select a roomy area with good footing, and ensure the safety of anyone in the area while working. Slowly move the front attachment. When using a signal person, coordinate hand signals before starting.

#### Removal

1. Park the machine on a level surface. Lower the bucket to the ground and position it with the flat surface resting on the ground. Be sure the bucket will not roll when the pins are removed.
2. Slide O-ring (1) out of its normal position toward the boss (2).
3. Remove bucket pins A and B to separate the arm and bucket.

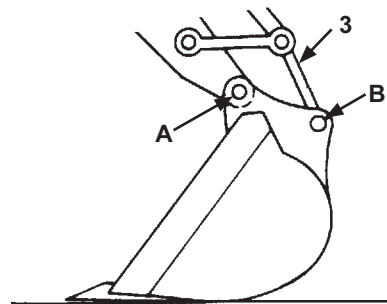
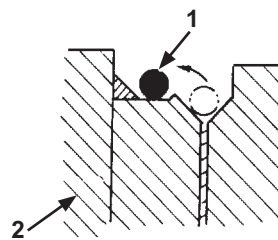

M104-07-063-4 ja

#### Installation

1. Clean the pins and pin bores. Apply sufficient grease to the pins and pin bores.
2. Place the new bucket in a stable position as shown in the figure.
3. Fit the arm to hole A and link (3) to hole B with the pins.
4. Install the locking pins and snap rings on each pin.
5. Install O-rings (1) to the specified positions.
6. Apply grease to each pin.
7. Start the engine and run it at slow idle. Slowly operate the bucket in both directions to check for any interference in bucket movement.

## MAINTENANCE

### 3 Adjust Track Sag (Rubber Crawler) and Check for Damage

--- daily

Swing the upperstructure 90 ° and lower the bucket to raise the track off the ground as shown. Rotate the rubber track so that the seam (1) of the rubber crawler comes to the center. Measure the clearance between the tread surface of the lower roller (2) and the inner ridge of the rubber track (3).

When doing so, be sure to place blocks under the machine frame to support the machine.

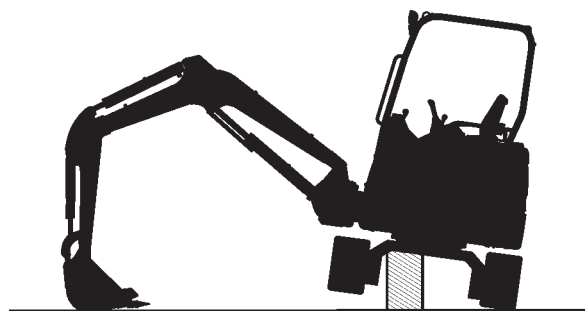

M1M7-04-006 ja

#### **CAUTION**

**Take care that no hands, feet, or other body parts are put beneath the track.**

	Measurement
Appropriate sag A (mm)	10 to 15

#### Adjusting Track Sag

1. If track sag is not within specifications, loosen or tighten the track following the procedures shown on the next page.
2. Adjust the tracks one at a time, with the track in the air. When doing so, be sure to place blocks under the machine frame to support the machine. To prevent accidents, care should be taken to ensure that hands, feet, and other parts of the body do not become entangled when working around the tracks.
3. After adjusting the sag on both sides, rotate the tracks backward and forward to equalize the sag on both sides.
4. Recheck the track sag one more time. Readjust as necessary.

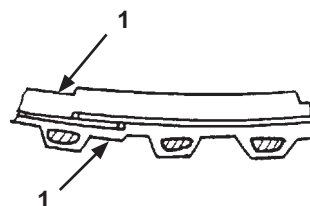

M102-07-075-3 ja

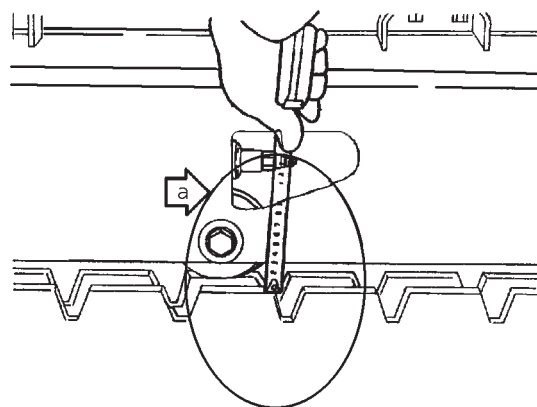

M588-07-055 ja

#### Checking Rubber Tracks for Damage

Check for damage to the tracks.

Consult your authorized dealer for repairs if any damage is found.

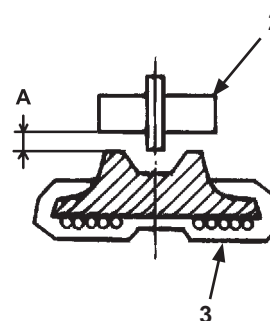

M503-05-050-3 ja



## MAINTENANCE

### Loosen Rubber Crawler

#### **⚠ WARNING**

The pressure inside the cylinder of the track adjuster is high. Do not loosen valve (1) quickly or loosen it too much as valve (1) may fly out or high-pressure grease in the adjusting cylinder may spout out. Slowly loosen valve (1) while keeping body parts and face away from valve. Never loosen grease fitting (2).

#### **IMPORTANT**

When gravel or mud is packed between sprockets and track links, remove it before loosening.

1. Use a deep 19 mm hex socket on the body of valve (1) and loosen the entire valve a little at a time; when grease is expelled from grease outlet (3), the track is loose.
2. Between 1 to 1.5 turns of valve (1) is sufficient to loosen the track. Do not loosen further than this.
3. If grease does not drain smoothly, slowly rotate the raised track.

#### **⚠ CAUTION**

Take care that no hands, feet, or other parts of the body are put beneath a track.

4. When proper track sag is obtained, turn valve (1) clockwise to the original condition.

Tightening Torque: 90 N·m (9 kgf·m)

#### **⚠ CAUTION**

If grease is not expelled properly, consult your authorized dealer.

### Tighten Rubber Crawler

#### **⚠ WARNING**

It is dangerous if the track cannot be adjusted. A powerful load acts on the spring in the track adjuster so the grease in the cylinder is at high pressure. Improper handling during adjustment or disassembly is extremely dangerous, possibly resulting in serious injury or death. Immediately consult the nearest Hitachi representative for repairs.

To tighten the track, connect a grease gun to grease fitting (2) and add grease until the sag is within specifications.

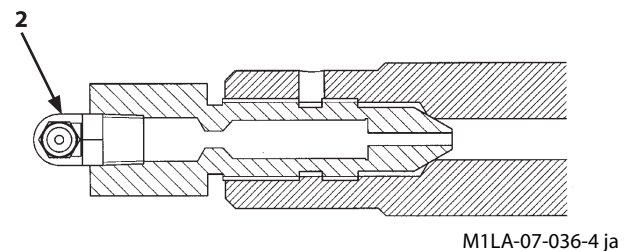
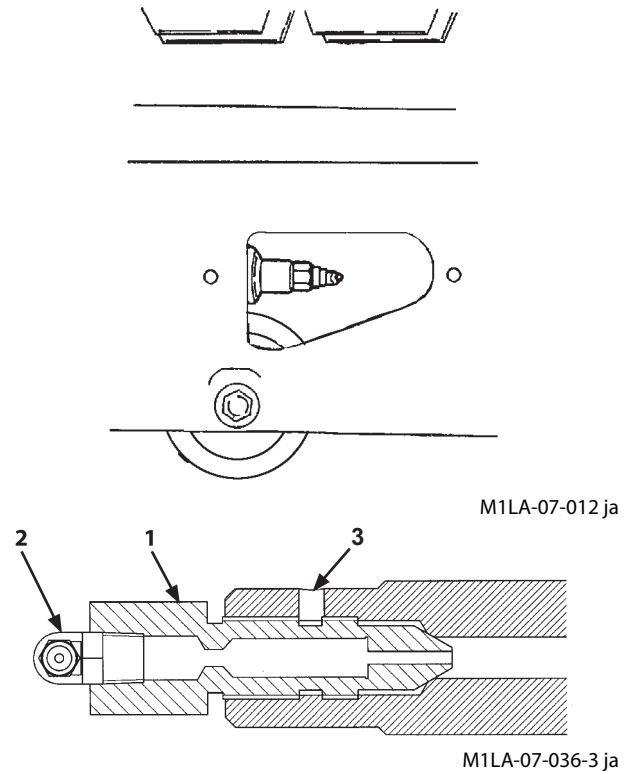

## MAINTENANCE

### 4 Replace Rubber Crawler

--- As required

#### WARNING

- The pressure inside the cylinder of the track adjuster is high. Do not loosen valve (1) quickly or loosen it too much as valve (1) may fly out or high-pressure grease in the adjusting cylinder may spout out. Slowly loosen valve (1) while keeping body parts and face away from valve. Never loosen grease fitting (2).
- When removing the rubber track, do not allow anyone to stand in front of the front idler. During this procedure, the high power track adjuster may suddenly release the front idler with extreme force, potentially resulting in personal injury or death.
- After the rubber track is removed, the front idler is free to come off. If the front idler comes off unexpectedly, personal injury and/or death may result.

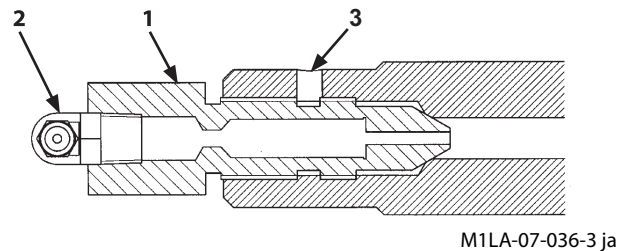
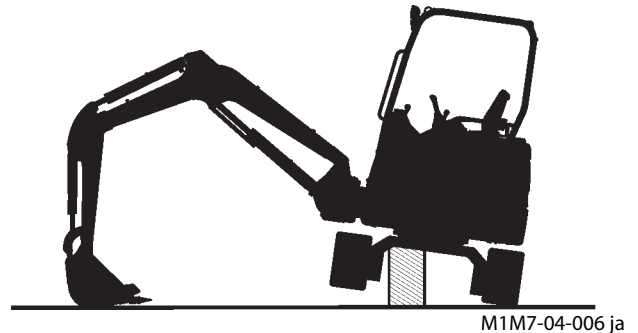

#### Removing Rubber Crawler

1. Lift the machine with the front attachment and the blade. When doing so, be sure to place blocks under the track frame to support the machine.
2. Loosen the body of valve (1) and expel grease inside from grease outlet (3).
3. Insert steel pipes (4) into the gaps among lower rollers, track frame and rubber track and slowly rotate the sprocket backwards. Use steel pipes (4) to lift the rubber track off the idler and slide it off sideways to remove it. Take steps to prevent the idler from coming off before remove the track from the idler. Then remove the track.

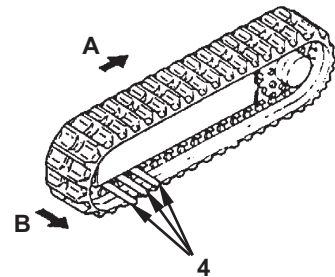

A: Direction of Track Rotation  
B: Direction to Remove Track

M503-07-062-2 ja

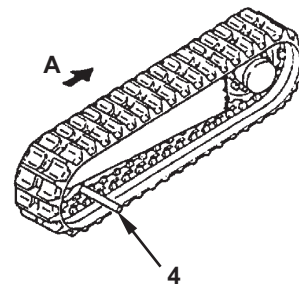

A: Direction of Track Rotation

M503-07-063-2 ja

## MAINTENANCE

### Installing Rubber Crawler

1. Lift the machine with the front attachment and the blade. When doing so, be sure to place blocks under the machine frame to support the machine.
2. Loosen the body of valve (1) and expel grease inside from grease outlet (3).
3. Fit the track onto the sprocket and put it on the idler.
4. Rotate the sprocket backwards and push in on the track.

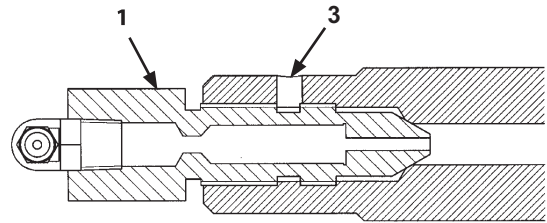

M1LA-07-036-5 ja

5. Insert steel pipes (4) into the gaps between lower rollers, track frame and rubber track and rotate the sprocket again. Fit the track securely onto the idler.
6. Make sure the track is securely on the sprocket and idler.
7. Refer to the section Tighten Track (Rubber Crawler) and adjust the tension of the track.
8. After making sure the track is fully engaged with the sprocket and idler and that the tension is correct, lower the machine.

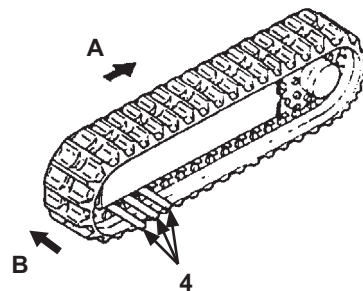

A: Direction of Track Rotation  
B: Direction to Push in Track

MABK-07-003-1 ja

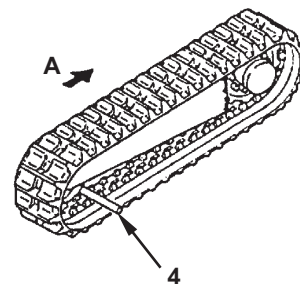

M503-07-063-2 ja

### Converting the Track

#### WARNING

- **Consult your authorized dealer for converting the track. During this procedure, the high power track adjuster may suddenly release the front idler with extreme force, potentially resulting in personal injury or death. When removing the rubber track, do not allow anyone to stand in front of the front idler.**
- **After the rubber track is removed, the front idle will become free to remove. If the front idle comes off unexpectedly, personal injury and/or death may result.**

Consult your authorized dealer for converting the track.  
Change the track adjuster whenever converting the track.

Change the track adjuster to one for use with the steel track whenever converting to the steel track from rubber. In the same way, ensure the same is done when converting from steel crawler to rubber crawler.

## MAINTENANCE

### 5 Check and Replace Seat Belt

Check --- daily

Replace --- every 3 years

Prior to operating the machine, thoroughly examine belt (1), buckle (2) and attaching hardware (3). If any item is damaged or significantly worn, replace seat belt or components before operating the machine.

We recommend the seat belt be replaced every 3 years regardless of its apparent condition.

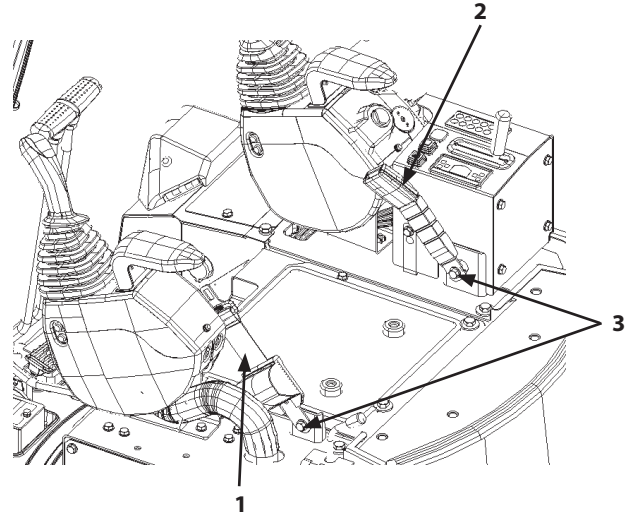

MABA-07-048-1 ja

### 6 Clean Cab Floor (ZX26U-6) (Cab equipped machine)

--- as required

#### IMPORTANT

Water can be used for cleaning inside the cab only for the floor. Take care not to splash the surrounding area. Do not increase water spray pressure by restricting the hose end, and do not use high pressure steam for cleaning. Always close ducts (1), fuse box and toolbox cover before cleaning the floor to prevent water from getting inside them.

1. Park the machine according to the instructions of (7-6) Preparations for Inspection and Maintenance.
2. Sweep the cab floor clean with a brush, and brush dust from the cab floor while spraying water. (Sweep out as much mud and dust as possible with a brush before using water.)
3. When cleaning the floor mat, sweep dust (water) along the grooves on the floor mat.
4. When cleaning the cab floor with the floor mat removed, remove only the rear mat and sweep the dust and/or water off from the step.

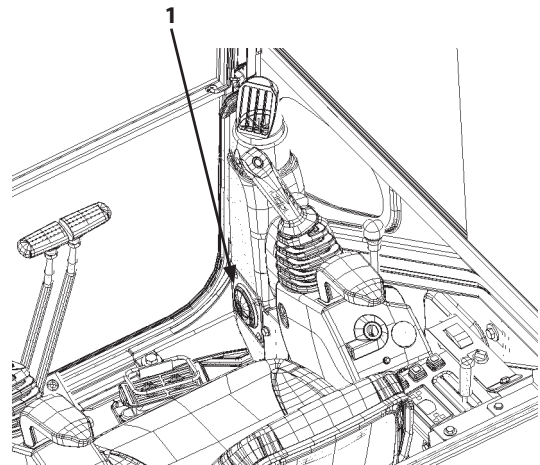

MABK-07-004-1 ja

## MAINTENANCE

---

### **7** Check, Clean and Function Check of Injection Nozzle

--- every 1500 hours

Consult your authorized dealer for inspection and repairs.

### **8** Inspect and Adjust Valve Clearance

--- every 1000 hours

Consult your authorized dealer for inspection and repairs.

### **9** Check and Adjust Injection Timing

--- every 1500 hours

Consult your authorized dealer for inspection and repairs.

### **10** Measure Engine Compression Pressure

---as required

Consult your authorized dealer for inspection and repairs.

### **11** Check Starter and Alternator

--- every 1000 hours

Consult your authorized dealer for inspection and repairs.

## MAINTENANCE

---

### **12** Check Crankcase Breather

--- every 1500 hours

Consult your authorized dealer for inspection and repairs.

### **13** Check Radiator Cap

--- every 2000 hours

Consult your authorized dealer for inspection and repairs.

## MAINTENANCE

---

### **14** Tightening and Retightening Torque of Bolts and Nuts

--- **every 250 hours (first time after 50 hours)**

Tighten or retighten nuts and bolts used on this machine in accordance with the torque values shown in the following table. Bolts and nuts should be replaced with those of the same or higher grade.

Check tightness after the first 50 hours, then every 250 hours.

Locations to be retightened other than those in the table should be tightened according to the torque table. Consult your authorized dealer for inspection and repairs.

## MAINTENANCE

### ZX17U-6,19U-6

No.	Descriptions		Bolt dia. mm	Qty.	Wrench size	Torque	
						N·m	(kgf·m)
1.	Engine cushion rubber mounting bolts		12	4	19	90	(9)
2.	Engine bracket mounting bolts (Front)		10	8	17	50	(5)
3.	Hydraulic oil tank mounting bolts		12	4	19	90	(9)
4.	ORS fittings for hydraulic hoses and piping	Metal Joints	7/16-20UNF		17	25	(2.5)
			9/16-18UNF		19	30	(3)
					22	40	(4)
			3/4-16UNF		27	65	(6.5)
		1-1/16-12UNF		36	180	(18)	
5.	Pump mounting bolts		12	2	19	90	(9)
6.	Pump cover mounting bolts		10	8	17	50	(5)
7.	Control valve mounting bolts		10	4	17	50	(5)
	Control valve base mounting bolts		10	4	17	50	(5)
8.	Swing device mounting bolts		12	4	19	90	(9)
9.	Battery mounting nuts		6	4	10	5	(0.5)
10.	Canopy mounting bolts		10	4	17	50	(5)
			14	5	22	140	(14)
11.	Swing bearing mounting bolts	Upperstructure	10	16	17	50	(5)
		Undercarriage	10	18	17	50	(5)
12.	Travel device mounting bolts		10	16	8 (socket)	65	(6.5)
13.	Sprocket mounting bolts		10	18	8 (socket)	65	(6.5)
14.	Lower roller mounting bolts		14	12	22	180	(18)
15.	Cover mounting bolts		6		10	5	(0.5)
			8		13	10	(1)
			10		17	50	(5)
16.	Counterweight mounting bolts		20	2	30	400	(40)
17.	Front pin lock bolts		8		13	20	(2)
			10		17	50	(5)
			12		19	90	(9)
			14		22	140	(14)
			16		24	210	(21)









## MAINTENANCE

### ZX26U-6

No.	Descriptions		Bolt dia. mm	Quantity	Wrench size	Torque	
						N·m	(kgf·m)
1.	Engine cushion rubber mounting bolts		12	4	19	90	(9)
2.	Engine bracket mounting bolts (Front)		10	8	17	50	(5)
3.	Hydraulic oil tank mounting bolts		12	4	19	90	(9)
4.	ORS fittings for hydraulic hoses and piping	Metal Joints	7/16-20UNF		17	25	(2.5)
			9/16-18UNF		19	30	(3)
					22	40	(4)
			3/4-16UNF		27	65	(6.5)
		1-1/16-12UNF		36	180	(18)	
5.	Pump mounting bolts		12	2	19	90	(9)
6.	Pump cover mounting bolts		10	8	17	50	(5)
7.	Control valve mounting bolts		10	4	17	50	(5)
	Control valve base mounting bolts		10	4	17	50	(5)
8.	Swing device mounting bolts		12	4	19	90	(9)
9.	Battery mounting nuts		6	4	10	5	(0.5)
10.	Canopy mounting bolts		12	8	19	110	(11)
11.	Cab mounting bolts		12	11	19	110	(11)
12.	Swing bearing mounting bolts	Upperstructure	12	16	19	110	(11)
		Undercarriage	12	20	19	110	(11)
13.	Travel device mounting bolts		12	12	19	110	(11)
14.	Sprocket mounting bolts		12	24	19	110	(11)
15.	Lower roller mounting bolts		14	16	22	180	(18)
16.	Cover mounting bolts		6		10	5	(0.5)
			8		13	10	(1)
			10		17	50	(5)
17.	Counterweight mounting bolts		20	2	30	400	(40)
18.	Front pin lock bolts		8		13	20	(2)
			10		17	50	(5)
			12		19	90	(9)
			14		22	140	(14)
			16		24	210	(21)

## MAINTENANCE

### Tightening Torque Chart

Bolt Dia. mm	Hexagon Wrench							Socket Bolt			
								Wrench size	Socket Bolt		Wrench size
	N·m(kgf·m)		N·m(kgf·m)		N·m(kgf·m)		mm	N·m	(kgf·m)	mm	
6					3.3 to 4.2 (0.3 to 0.4)		10			5	
8	30	(3.0)	20	(2.0)	10	(1.0)	13	20	(2.0)	6	
10	65	(6.5)	50	(5.0)	20	(2.0)	17	50	(5.0)	8	
12	110	(11)	90	(9.0)	35	(3.5)	19	90	(9.0)	10	
14	180	(18)	140	(14)	55	(5.5)	22	140	(14)	12	
16	270	(27)	210	(21)	80	(8.0)	24	210	(21)	14	
18	400	(40)	300	(30)	120	(12)	27	300	(30)	14	
20	550	(55)	400	(40)	170	(17)	30	400	(40)	17	
22	750	(75)	550	(55)	220	(22)	32				
24	950	(95)	700	(70)	280	(28)	36				
27	1400	(140)	1050	(105)	400	(40)	41				
30	1950	(195)	1450	(145)	550	(55)	46				
33	2600	(260)	1950	(195)	750	(75)	50				
36	3200	(320)	2450	(245)	950	(95)	55				

 **CAUTION**

If fixing bolts for counterweight are loosened, consult your nearest authorized dealer.

**IMPORTANT**

Apply lubricant (e. g. white zinc B solved into spindle oil) to bolts and nuts to stabilize their friction coefficient.

Remove soil, dust, and/or dirt from the nut and bolt thread surfaces before tightening.

Tighten nuts and bolts to specifications.

If tightened with excessively low or high torque, missing or breakage of nuts and/or bolts may result.

## MAINTENANCE UNDER SPECIAL ENVIRONMENTAL CONDITIONS

### Maintenance Under Special Environmental Conditions

Suitable consideration must be given when operating under special conditions. Take note of the following and operate safely and as instructed.

Operating Conditions	Precautions for Maintenance	
Muddy Soil, Rainy or Snowy Weather	After Operation	Clean the machine and check for cracks, damage, loose or missing bolts and nuts. Lubricate all necessary parts without delay.
Near the Ocean	After Operation	The following measures to prevent salt contamination must be taken when the machine is operated at sea or near the coastline.
		(1) After completing the work, extend/retract the hydraulic cylinders several times to form an oil film on the rod surface. Store the machine with cylinders retracted as much as possible.
		(2) Thoroughly clean the machine with fresh water to wash off salt.
		(3) To prevent corrosion, touch up paint periodically on hose fittings, lubrication piping and where covers come together and sea water collects readily.
Dusty Atmosphere	Air Cleaner	Service the filter element and strainer more often.
	Radiator	Clean the radiator often to prevent clogging of the radiator core.
	Fuel System	Service the filter element and strainer more often.
	Electrical Equipment	In particular, clean surfaces of the starter, alternator and commutator.
Rocky Ground	Track	Pay attention to and look for cracks, damage and loose bolts and nuts. Loosen the tracks a little more than usual. Do not use rubber crawlers.
	Front Attachment	Doing heavy duty work with a standard attachment will damage it. Choose the appropriate attachment or reinforce it before use.
Falling Stones	Cab Head Guard	Always keep installed. Consult your authorized dealer for installation.
Freezing Weather	Fuel/Lubricants	Use high quality and low viscosity fuel and oil.
	Engine Coolant	Be sure to use antifreeze.
	Battery	Fully charge the batteries at shorter intervals. If not fully charged, electrolyte may freeze.
	Track	Keep the tracks clean. Park the machine on a hard surface to prevent the tracks from freezing to the ground.
Sites at High Altitude (Above 1500 m)*	Engine Oil	Replace at 1/2 the normal interval.
	Engine Oil Filter	Replace at 1/2 the normal interval.

\*At 1,500 meters and higher a deterioration of engine combustion performance can be expected, resulting in a drastic drop in its function and durability. If it must be used regardless, consult your nearest authorized dealer.

**MAINTENANCE UNDER SPECIAL ENVIRONMENTAL CONDITIONS**

---

---

**MEMO**

## STORAGE

### Storing the Machine

It is necessary to prepare the machine for storage of over 1 month to prevent any loss of function. Note and follow the instructions below.

Item	Remedy
Wash the machine	Wash the machine. Remove soil or other debris adhering to the machine.
Lubrication/Greasing	Check lubricants for level and contamination. Fill up or change if necessary. Lubricate all grease points. Use grease to coat parts like cylinder rods that are subject to rust.
Battery	Remove and fully charge for storage, or turn the disconnect switch OFF, or disconnect the negative terminal.
Coolant	Add anti-rusting agent. If storing in extremely cold areas, either add extra anti-freeze or drain coolant sufficiently to avoid freezing. In this case, place a sign reading "NO COOLANT".
Protection Against Dust and Moisture	Store the machine in a dry storage area using a protective cover.
Tools	Inspect and repair, then store.
Lubrication Operation	If the oil film on the metal surfaces is lost, rust may form. This may cause abnormal wear of the machine the next time the machine is operated. If the machine is to be stored for a long time, at least once a month operate the following hydraulic functions two to three times for lubrication: Travel, swing and digging. Be sure to check the coolant level and lubrication conditions before operating. Charge the battery at the same time.

 **NOTE**

- *Lubricating operation means a series of warm-up, travel, swing and digging operations carried out repeatedly 2-3 times at slow speed.*
- *Lubricants deteriorate during long term storage of the machine. Be sure to carefully check the lubricants before resuming operation of the machine.*
- *Refer to the section Guide to Using Rubber Crawlers of Chapter 5 Operation Guidance for machines equipped with rubber crawlers.*

## STORAGE

---

MEMO

# TROUBLESHOOTING

## Troubleshooting

If any problems with the machine occur, repair them immediately. Confirm the cause and takes steps to prevent recurrence.

If it is difficult to determine the cause, or if measures marked with \* must be taken, consult your authorized dealer.

### IMPORTANT

**Never attempt to disassemble, adjust or repair hydraulic or electrical/electronic components.**

#### Engine

Consult your authorized dealer for engine troubleshooting.

#### Engine Auxiliaries

Problem	Cause	Solution
Batteries will not charge.	Damaged battery separator	Replace
	Faulty regulator	Adjust and/or replace <sup>*1</sup>
	Faulty ground line	Repair <sup>*1</sup>
	Faulty alternator	Repair or replace <sup>*1</sup>
Batteries discharge quickly after being charged.	Shorted cable	Repair or replace <sup>*1</sup>
	Plates inside the battery are shorting	Repair or replace <sup>*1</sup>
	Increased sediment in battery	Replace <sup>*1</sup>
Coolant temperature too high	Low coolant level	Refill
	Insufficient fan belt tension	Adjust
	Damaged rubber hose	Replace <sup>*1</sup>
	Faulty thermostat	Replace <sup>*1</sup>

Item marked with <sup>\*1</sup>: Contact your authorized dealer.

## TROUBLESHOOTING

### Impossible to Start the Engine

Problem	Cause	Solution	
Engine will not start	Starter does not rotate or is not powerful.	Discharged battery	Charge or replace battery.
		Battery disconnect switch is in the OFF position	Turn the battery disconnect switch to the ON position
		Disconnected, loose, or corroded battery terminals	After repairing the corroded area, securely tighten the connectors.
		Pilot control shut-off lever is lowered.	Pull pilot control shut-off lever up.
		Disconnected, loose, or corroded starter ground line terminals.	After repairing the corroded area, securely tighten the connectors.
		Faulty pilot control shut-off lever electrical system	Repair
		Engine oil viscosity too high	Change engine oil with appropriate viscosity.
		Faulty starter and/or electrical system	Repair or adjust <sup>*1</sup>
	Starter rotates	No fuel	After checking that no fuel is leaking, refill fuel.
		Injection pump faulty	Repair or adjust <sup>*1</sup>
		Air in the fuel system	Bleed air
		Clogged fuel filter	Replace element after draining water
		Frozen fuel	Warm the fuel pump with hot water or wait until the atmospheric temperature rises.
		Faulty preheat system	Repair or adjust <sup>*1</sup>
Even though the engine starts, it stalls shortly afterwards.	Too low idle speed	Repair or adjust <sup>*1</sup>	
	Clogged fuel filter	Replace element after draining water	
	Faulty engine control system	Repair or adjust <sup>*1</sup>	
	Clogged air cleaner	Clean or replace the element.	
	Injection pump faulty	Repair or adjust <sup>*1</sup>	
Engine runs irregularly.	Faulty fuel system	Repair or adjust <sup>*1</sup>	
	Water or air in the fuel system	Bleed air	
	Faulty engine control system	Repair or adjust <sup>*1</sup>	

Item marked with <sup>\*1</sup>: Contact your authorized dealer.



## TROUBLESHOOTING

---

---

### Control Lever

Problem	Cause	Solution
Lever is heavy to operate.	Rusted joint	Lubricate or repair <sup>*1</sup>
	Worn pusher	Replace <sup>*1</sup>
Does not move smoothly.	Worn pusher	Repair or replace <sup>*1</sup>
	Faulty pilot valve	Replace <sup>*1</sup>
Does not return to neutral	Faulty pilot valve	Replace <sup>*1</sup>
The lever is tilted in the neutral position due to increase in play.	Worn joint	Repair or replace <sup>*1</sup>
	Faulty pilot valve	Replace <sup>*1</sup>

Item marked with <sup>\*1</sup>: Contact your authorized dealer.

## TROUBLESHOOTING

### Hydraulic System

When the machine is stored without running for a long period, air mixed in the hydraulic oil will separate and accumulate in the upper part of cylinders, causing a delay in the response time of machine movements and/or weak power.

If these symptoms appear, operate all actuators repeatedly several times.

Problem	Cause	Solution
Front, swivel and travel fail to operate (noise from hydraulic pump gets loud)	Faulty hydraulic pump	Repair or replace <sup>*1</sup>
	Lack of hydraulic oil	Refill
	Broken suction pipe and/or hose	Repair or replace <sup>*1</sup>
Front, swivel and travel fail to operate (no change in noise from hydraulic pump)	Faulty pilot pump	Replace <sup>*1</sup>
	Faulty pilot shut-off solenoid valve	Replace <sup>*1</sup>
	Faulty wire harness (pilot shut-off solenoid valve) pilot shut-off switch	Repair or replace <sup>*1</sup>
	The pilot control shut-off lever is in the LOCK position.	Turn the pilot control shut-off lever to the UNLOCK position.
No actuators have any power	Malfunction due to worn hydraulic pump	Replace <sup>*1</sup>
	Decreased main relief valve set pressure in the control valve	Adjust <sup>*1</sup>
	Lack of hydraulic oil	Refill
	Clogged suction strainer in the hydraulic oil tank	Clean
	Absorption of air from the oil suction side	Retighten
Only one side lever is inoperable or has no power.	Faulty relief valve in the control valve	Repair or replace <sup>*1</sup>
	Broken pipe and/or hose	Repair or replace <sup>*1</sup>
	Loose pipe line joint	Retighten
	Broken O-ring at pipe line joint	Replace <sup>*1</sup>
	Faulty hydraulic pump	Repair or replace <sup>*1</sup>
	Faulty pilot valve	Replace <sup>*1</sup>
	Faulty pilot circuit line	Repair or replace <sup>*1</sup>
	Faulty pilot solenoid valve	Repair or replace <sup>*1</sup>

Item marked with <sup>\*1</sup>: Contact your authorized dealer.

## TROUBLESHOOTING

Problem	Cause	Solution
Only one actuator is inoperable	Broken control valve spool	Replace <sup>*1</sup>
	Embedded foreign matter in valve spool	Repair or replace <sup>*1</sup>
	Broken pipe and/or hose	Repair or replace <sup>*1</sup>
	Loose pipe line joint	Retighten
	Broken O-ring at pipe line joint	Replace <sup>*1</sup>
	Broken actuator	Repair or replace <sup>*1</sup>
	Faulty pilot valve	Replace <sup>*1</sup>
	Faulty pilot circuit line	Repair or replace <sup>*1</sup>
One cylinder is inoperable or has no power	Broken oil seal in cylinder	Repair or replace <sup>*1</sup>
	Oil leak due to damage to cylinder rod	Repair or replace <sup>*1</sup>
	Faulty pilot valve	Replace <sup>*1</sup>
	Faulty pilot circuit line	Repair or replace <sup>*1</sup>
	Pressure setting of main or port relief valves (boom, arm, bucket) decreased/faulty	Adjust and/or replace <sup>*1</sup>
Hydraulic oil temperature increases	Stained oil cooler	Clean
	Insufficient engine fan belt tension	Adjust
Oil leak from low pressure hose	Loose clamps	Retighten

Item marked with <sup>\*1</sup>: Contact your authorized dealer.

## TROUBLESHOOTING

### Drive Function

Problem	Cause	Solution
One or both side tracks are inoperable.	Damaged center joint	Repair or replace <sup>*1</sup>
	Incompletely released parking brake	Repair or replace <sup>*1</sup>
	Broken travel motor	Repair or replace <sup>*1</sup>
	Faulty pilot valve	Replace <sup>*1</sup>
	Faulty pilot circuit line	Repair or replace <sup>*1</sup>
	Faulty counter-balance valve	Replace <sup>*1</sup>
Does not travel smoothly	Overly tensioned or slackened crawler sag	Adjust
	Deformed track frame	Repair or replace <sup>*1</sup>
	Embedded foreign matter such as rock fragments	Remove
	Dragged parking brake	Repair <sup>*1</sup>
	Faulty counter-balance valve	Replace <sup>*1</sup>
Travel speed does not change	Damaged travel speed switch	Replace <sup>*1</sup>
	Poor contact in connector	Repair or replace <sup>*1</sup>
	Damaged wire harness	Repair <sup>*1</sup>
	Faulty solenoid valve	Repair or replace <sup>*1</sup>
	Faulty motor	Repair or replace <sup>*1</sup>

Item marked with <sup>\*1</sup>: Contact your authorized dealer.

## TROUBLESHOOTING

### Swing Function

Problem	Cause	Solution
Upperstructure does not swing	Faulty swing parking brake	Repair or replace <sup>*1</sup>
	Broken swing motor	Repair or replace <sup>*1</sup>
	Faulty pilot valve	Replace <sup>*1</sup>
	Faulty pilot circuit line	Repair or replace <sup>*1</sup>
	Decreased pressure setting for the swing relief valve	Adjust and/or replace <sup>*1</sup>
Swing is not smooth	Worn swing internal gear	Repair or replace <sup>*1</sup>
	Damaged swing bearing and bearing balls	Repair or replace <sup>*1</sup>
	Lack of grease	Refill
	Decreased pressure setting for the swing relief valve	Adjust and/or replace <sup>*1</sup>

Item marked with <sup>\*1</sup>: Contact your authorized dealer.

Just after the control valve, swing motor relief valve and/or the swing motor is replaced, noise may be produced when swinging and it may not operate smoothly. This is because air has accumulated in the hydraulic circuit for swinging. Slowly continue to operate the machine for approx. 10 minutes to bleed air.

After repair work is complete, be sure to check the oil level in the hydraulic oil tank. Refill hydraulic oil as needed.

### Other

The machine may make abnormal noise, vibration, and/or smells when there is a problem. Always pay attention to the machine conditions during operation.

## TROUBLESHOOTING

---

MEMO

## SPECIFICATIONS

### Specifications ZX17U-6

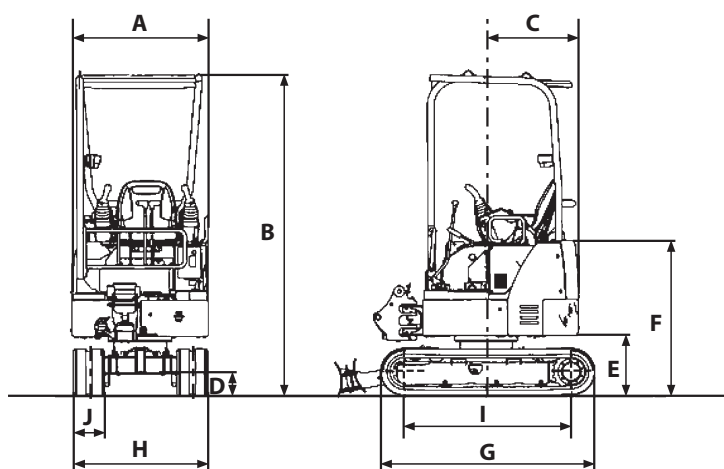

MABC-12-001-2 ja

Specification		3-Pillars Canopy
Type of Front-End Attachment	-	Boom Swing Type
Bucket Capacity (Heaped)	m <sup>3</sup>	0.044 (0.060)
Operating Weight	kg	1780
Base Machine Weight	kg	1490
Engine Type	-	3TNV70
Engine Power	kW/min <sup>-1</sup>	ISO14396:11.5/2400      ISO9249:10.6/2400
A: Overall Width	mm	990
B: Overall Height	mm	2380
C: Rear End Swing Radius	mm	680
D: Minimum Ground Clearance	mm	165
E: Counterweight Clearance	mm	450
F: Engine Cover Height	mm	1150
G: Undercarriage Length	mm	1570
H: Undercarriage Width	mm	980/1280
I: Sprocket Center to Idler Center	mm	1210
J: Track Shoe Width	mm	230
Ground Pressure	kPa (kgf/cm <sup>2</sup> )	26 (0.27)
Swing Speed	min <sup>-1</sup> (rpm)	9.4
Travel Speed (fast/slow)	km/h	4.2/2.4
Gradeability		25°(tan θ = 0.47)

**NOTE**

The dimensions do not include the height of the shoe lug. The dimensions of the machine equipped with rubber crawlers are shown.

## SPECIFICATIONS

### Specifications ZX19U-6

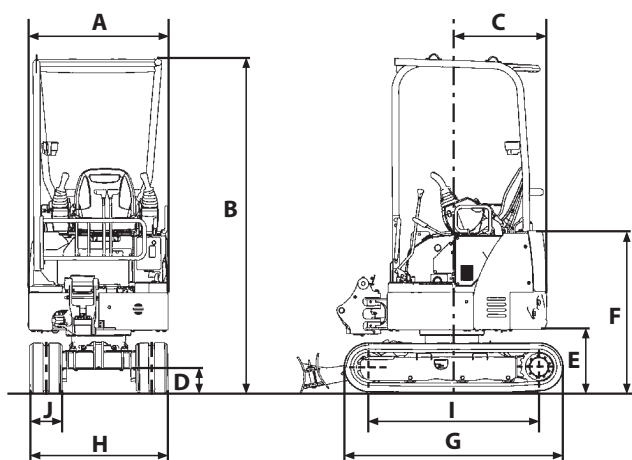

MABK-12-001-2 ja

Specification		3-Pillars Canopy	
Type of Front-End Attachment	-	Boom Swing Type	
Bucket Capacity (Heaped)	m <sup>3</sup>	0.040 (0.050)	
Operating Weight	kg	1900	
Base Machine Weight	kg	1600	
Engine Type	-	3TNV70	
Engine Power	kW/min <sup>-1</sup>	ISO14396:11.5/2400	ISO9249:10.6/2400
A: Overall Width	mm	990	
B: Overall Height	mm	2380	
C: Rear End Swing Radius	mm	755	
D: Minimum Ground Clearance	mm	165	
E: Counterweight Clearance	mm	450	
F: Engine Cover Height	mm	1150	
G: Undercarriage Length	mm	1570	
H: Undercarriage Width	mm	980/1280	
I: Sprocket Center to Idler Center	mm	1210	
J: Track Shoe Width	mm	230	
Ground Pressure	kPa (kgf/cm <sup>2</sup> )	28 (0.29)	
Swing Speed	min <sup>-1</sup> (rpm)	9.4	
Travel Speed (fast/slow)	km/h	4.2/2.4	
Gradeability		25°(tan θ = 0.47)	

**NOTE**

The dimensions do not include the height of the shoe lug. The dimensions of the machine equipped with rubber crawlers are shown.



## SPECIFICATIONS

### Specifications ZX26U-6

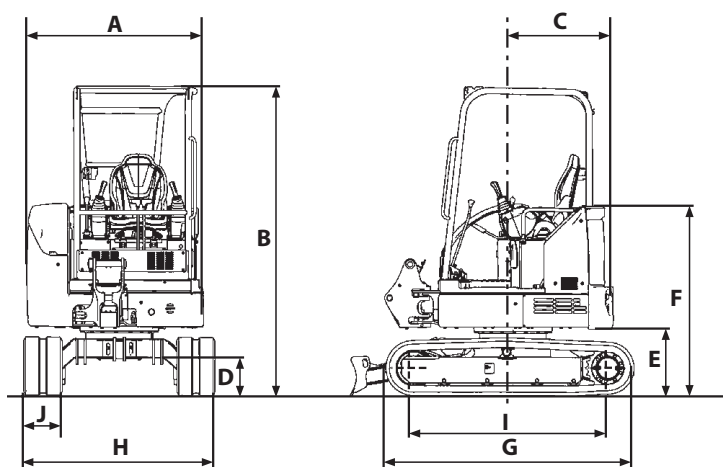

MABA-12-004-2 ja

Specification		4-Pillars Canopy	Cab
Type of Front-End Attachment	-	Boom Swing Type	
Bucket Capacity (Heaped)	m <sup>3</sup>	0.080 (0.070)	
Operating Weight	kg	2650	2740
Base Machine Weight	kg	2040	2130
Engine Type	-	3TNV76	
Engine Power	kW/min <sup>-1</sup>	ISO14396:15.6/2500	ISO9249:14.5/2500
A: Overall Width	mm	1390	1420
B: Overall Height	mm	2430	
C: Rear End Swing Radius	mm	795	870
D: Minimum Ground Clearance	mm	300	
E: Counterweight Clearance	mm	530	
F: Engine Cover Height	mm	1490	1470
G: Undercarriage Length	mm	1960	
H: Undercarriage Width	mm	1500	
I: Sprocket Center to Idler Center	mm	1530	
J: Track Shoe Width	mm	300	
Ground Pressure	kPa (kgf/cm <sup>2</sup> )	24 (0.25)	25 (0.25)
Swing Speed	min <sup>-1</sup> (rpm)	9.1	
Travel Speed (fast/slow)	km/h	4.5/2.9	
Gradeability		25°(tan θ = 0.47)	

**NOTE**

- The dimensions do not include the height of the shoe lug. The dimensions of the machine equipped with rubber crawlers are shown.
- The specifications include additional counterweight and extra attachment lines.

## SPECIFICATIONS

### Working Ranges ZX17U-6

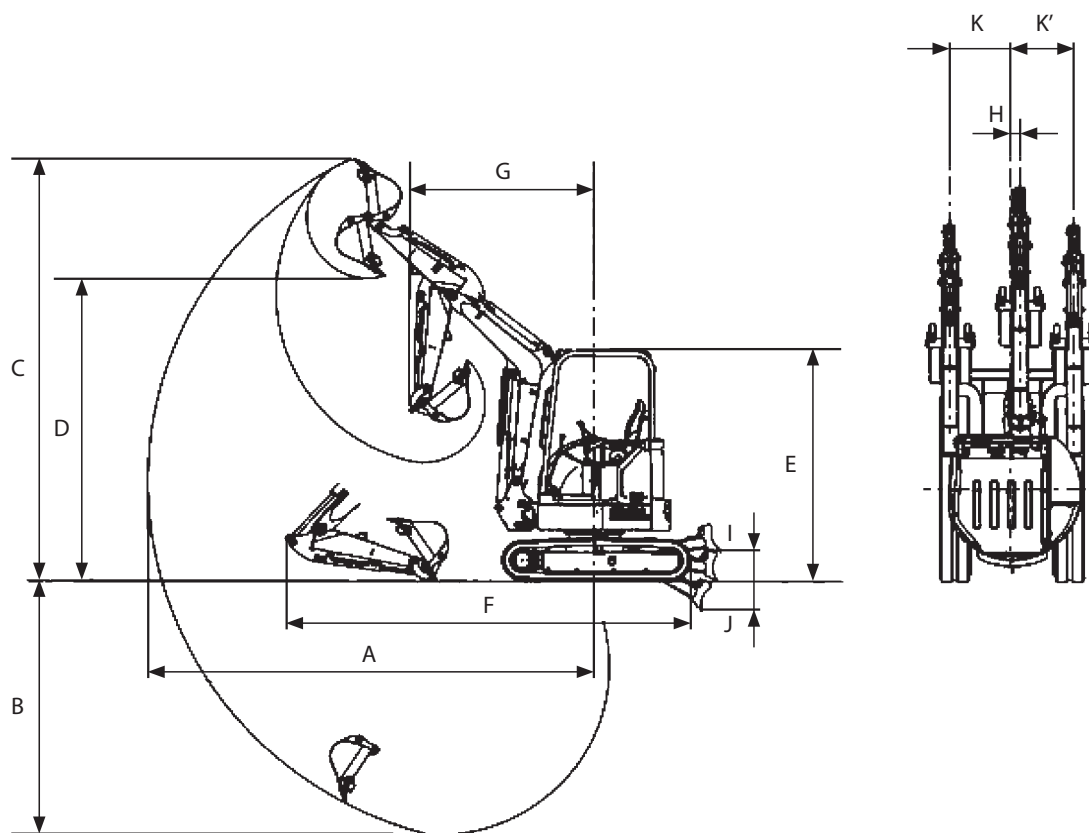

MABK-12-002-1 ja

Item	Category	3-Pillars Canopy	
A: Maximum Digging Reach	mm	3810	
B: Maximum Digging Depth	mm	2190	
C: Maximum Cutting Height	mm	3540	
D: Maximum Dumping Height	mm	2510	
E: Overall Height	mm	2380	
F: Overall Length	mm	3500	
G: Minimum Swing Radius	mm	1530	
H: Boom Swing Pivot Offset Distance	mm	105	
I: Blade Bottom Highest Position	mm	285	
J: Blade Bottom Lowest Position	mm	225	
K(K'): Offset Distance	mm	K 355	K' 555

**NOTE**

The dimensions do not include the height of the shoe lug. The dimensions of the machine equipped with rubber crawlers are shown.

## SPECIFICATIONS

### Working Ranges ZX19U-6

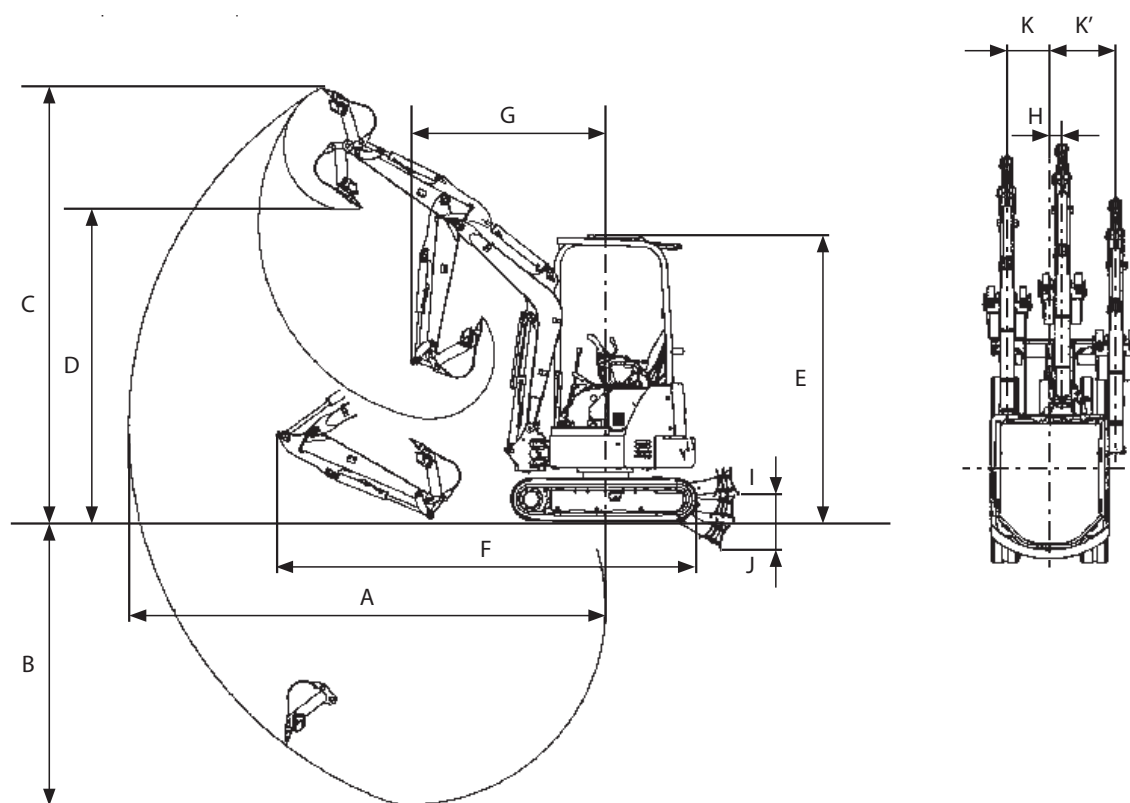

MABA-12-006-1 ja

Item	Category	3-Pillars Canopy	
A: Maximum Digging Reach	mm	3990	
B: Maximum Digging Depth	mm	2390	
C: Maximum Cutting Height	mm	3640	
D: Maximum Dumping Height	mm	2610	
E: Overall Height	mm	2380	
F: Overall Length	mm	3540	
G: Minimum Swing Radius	mm	1620	
H: Boom Swing Pivot Offset Distance	mm	105	
I: Blade Bottom Highest Position	mm	285	
J: Blade Bottom Lowest Position	mm	225	
K(K'): Offset Distance	mm	K 355	K' 555

**NOTE**

- The dimensions do not include the height of the shoe lug. The dimensions of the machine equipped with rubber crawlers are shown.

## SPECIFICATIONS

### Working Ranges ZX26U-6

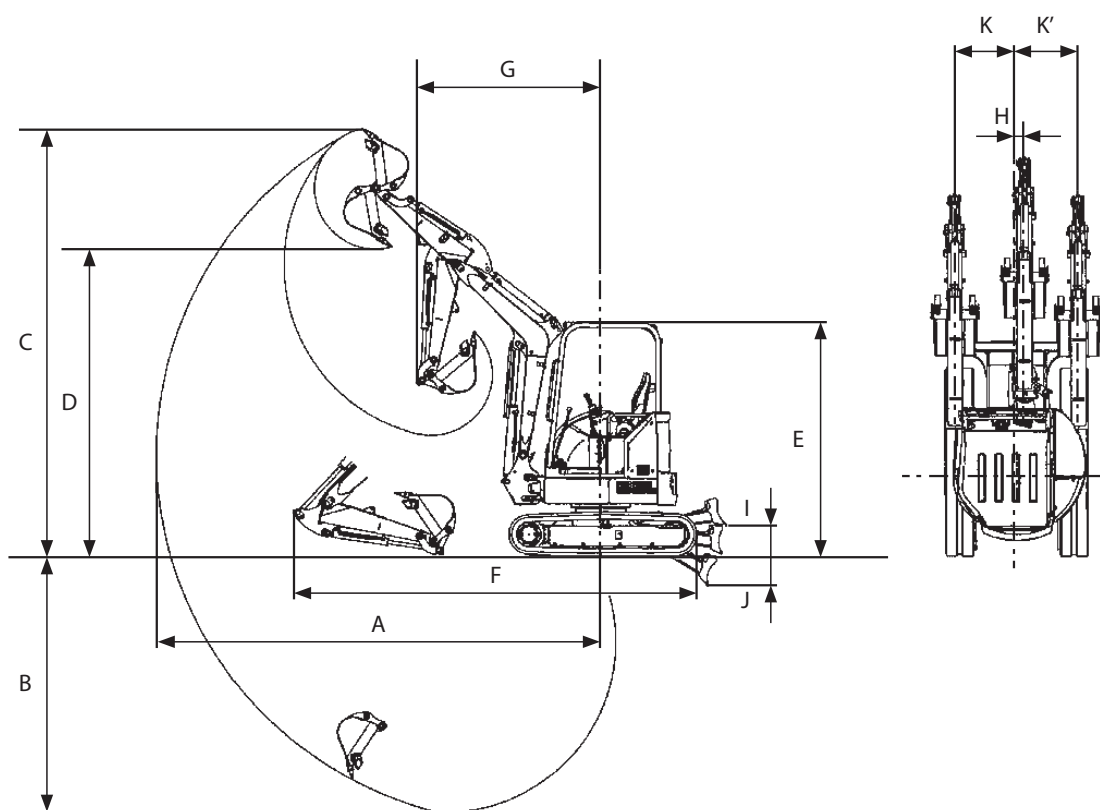

MABA-12-008-1 ja

Item	Category	4-Pillars Canopy	Cab
		1.30 m Arm	1.30 m Arm
A: Maximum Digging Reach	mm	4710	4710
B: Maximum Digging Depth	mm	2730	2730
C: Maximum Cutting Height	mm	4450	4260
D: Maximum Dumping Height	mm	3200	3030
E: Overall Height	mm	2430	
F: Overall Length	mm	4180	4180
G: Minimum Swing Radius	mm	1940	2020
H: Boom Swing Pivot Offset Distance	mm	85	
I: Blade Bottom Highest Position	mm	320	
J: Blade Bottom Lowest Position	mm	315	
K(K'): Offset Distance	mm	K 555	K' 700

**NOTE**

- The dimensions do not include the height of the shoe lug. The dimensions of the machine equipped with rubber crawlers are shown.

## SPECIFICATIONS

### Bucket Types and Applications

Use a combination in the table below when using a bucket. If a combination not in the table is used, such as a high-capacity or special bucket, the stability of the machine cannot be ensured and excessive forces are exerted on the body, front attachment and cylinders, which will damage the machine.

Do not use with any combination other than in the following table.

#### ZX17U-6

Bucket	Bucket Capacity m <sup>3</sup> ISO (Heaped)	Bucket Width mm		Front-End Attachment Arm
		(With side cutter) mm	(Without side cutter) mm	
Hoe Bucket	0.02	300	250	⊙
	0.035	350	300	⊙
	0.04	400	350	⊙
	0.044	450	400	⊙
	0.05	500	450	○

 **NOTE**

- ⊙ : *General excavating*
- : *Light duty excavating*
- : *Loading work*

## SPECIFICATIONS

### ZX19U-6

Bucket	Bucket Capacity m <sup>3</sup> ISO (Heaped)	Bucket Width mm		Front-End Attachment 1.13 m Arm
		(With side cutter) mm	(Without side cutter) mm	
Hoe Bucket	0.02	300	250	⊙
	0.035	350	300	⊙
	0.04	400	350	⊙
	0.044	450	400	○
	0.05	500	450	□

 **NOTE**

- Symbols in the above table have the following meanings.
  - ⊙ : General excavating
  - : Light duty excavating
  - : Loading work
- A hoe bucket is applicable to the following types of work. General excavating: For digging and loading operation of sand, gravel, clay, ordinary earth and so on. Light duty excavating: For digging and loading operation of dried, loosened earth, sand, mud and so on. Their bulk density to be less than 1600 kg/m<sup>3</sup> as a standard. Loading work: For loading operation of dried, loosened earth and sand. Their bulk density to be less than 1100 kg/m<sup>3</sup> as a standard.

## SPECIFICATIONS

### ZX26U-6

Bucket	Bucket Capacity m <sup>3</sup> ISO (Heaped)	Bucket Width mm		Front-End Attachment 1.30 m Arm
		(With side cutter) mm	(Without side cutter) mm	
Hoe Bucket	0.07	450	400	⊙
	0.08	500	450	○

 **NOTE**

- Symbols in the above table have the following meanings.
- ⊙ : General excavating
- : Light duty excavating
- A hoe bucket is applicable to the following types of work. General excavating: For digging and loading operation of sand, gravel, clay, ordinary earth and so on. Light duty excavating: For digging and loading operation of dried, loosened earth, sand, mud and so on. Their bulk density to be less than 1600 kg/m<sup>3</sup> as a standard.

## SPECIFICATIONS

### Noise Level Results

(2000/14/EC)

(2006/42/EC)

LwA : guaranteed sound power level of airborne noise (ISO 6395:1988)

LpA : sound pressure level at operator' s station (ISO 6396:2008)

Unit:db(A)

	Cab		Canopy	
	LwA	LpA	LwA	LpA
ZX17U-6	–	–	93	76
ZX19U-6	–	–	93	76
ZX26U-6	93	78	93	77

### Electric Fans

We consider our products exempt from EU regulation 327/2011, implementing EU directive 2009/125/EC, based on the fact that the fans are considered battery powered as the energy supply recharging the battery is not continuous nor at a constant level.

### The Value of the Carbon Dioxide (CO<sub>2</sub>) Emissions

This CO<sub>2</sub> measurement results from testing over a fixed test cycle under laboratory conditions a(n) (parent) engine representative of the engine type (engine family) and shall not imply or express any guarantee of the performance of a particular engine.

Model	Power category	Family name	Parent engine model	Test cycle	CO <sub>2</sub> Value [g/kWh]
ZX17U-6 ZX19U-6	0-19kW	YD085PNLNV2A	3TNV70-DM	NRSC	995
ZX26U-6	0-19kW	YD112PNLNV2A	3TNV76-DM	NRSC	932



# SPECIFICATIONS

## Lifting Capacities and Machine Capacities

The section regarding lifting capacities provides information on capacities when the machine is used for lifting applications. For general information regarding safety precautions during lifting operation, please read the information provided in the machine's operator's manual and follow local regulations and instructions.

The section with information regarding machine capacities is intended for applications other than lifting operation. It provides information relevant for the selection of suitable attachments, matching the machine's capacities. Please take into account the machine's intended use when selecting attachments to avoid misuse and potential damage to the machine.









### Conditions related to Lifting Capacities

- Lifting capacity of the ZX series does not exceed 75 % of tipping load with the machine on firm, level ground or 87% of full hydraulic capacity. (ISO 10567)
- \*Indicates load limited by hydraulic capacity.

### How to Use This Lifting Capacities Chart

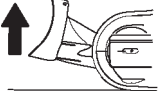
- Net lifting capacities are equal to the values obtained by deducting the ATT mass from the values described in the table.
- Capacities shown are metric measure.

### Symbols Used in This Book

A:	Load radius (m)
B:	Load point height (m)
C:	Lifting capacity (kg)
D:	Value at the maximum load radius (lifting capacity) (kg)
E:	Value at the maximum load radius (reach) (m)
	Rating over-front
	Rating over-side or 360 degrees
	Canopy
	Cab
	Equipped with Blade
	Mono block boom
	Arm
	Counterweight

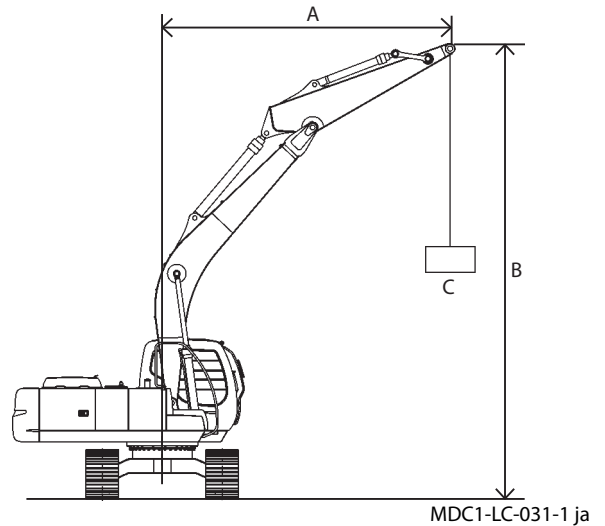

- A: Load radius
- B: Load point height
- C: Lifting capacity

# SPECIFICATIONS

## Lifting Capacities

### ZX17U-6

**Boom 1.82 m, Counterweight 120 kg**

Canopy

Arm		Z \ X	Unit; kg			MAX	
			1	2	3	REACH [m]	
0.93 m	Z2		400	220	200	3.27	
	Z1		380	210	200	3.15	
	Z3		380		270	2.58	

### ZX19U-6

**Boom 1.82 m, Counterweight 240 kg**

Canopy

Arm		Z \ X	Unit; kg			MAX	
			1	2	3	REACH [m]	
1.13 m	Z2		490	270	220	3.44	
	Z1		460	260	230	3.34	
	Z3		450		290	2.81	

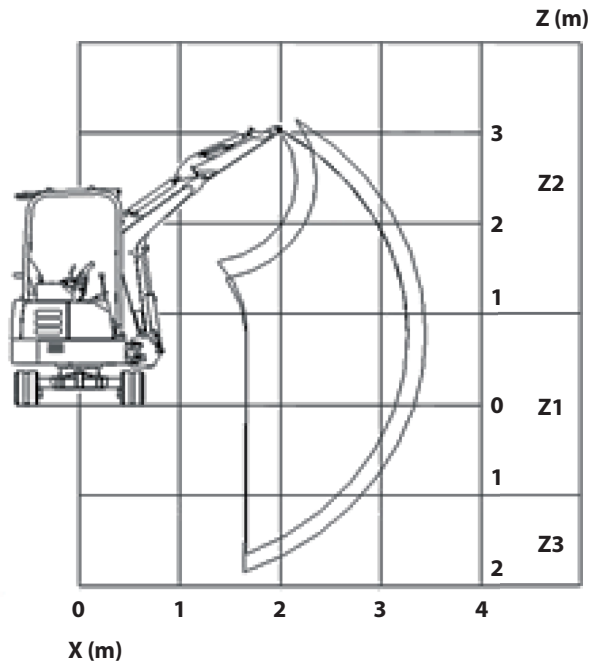

MABK-12-003-1 ja

## SPECIFICATIONS

### ZX26U-6

#### Boom 2.10 m, Counterweight 240 kg

Canopy

Arm		Z \ X		1    2    3    4				Unit; kg	
								MAX	REACH [m]
1.30 m	Z2			370	250	230	4.07		
	Z1		630	350		240	3.90		
	Z3		630	350		300	3.35		

#### Boom 2.10 m, Counterweight 150 kg

Cab

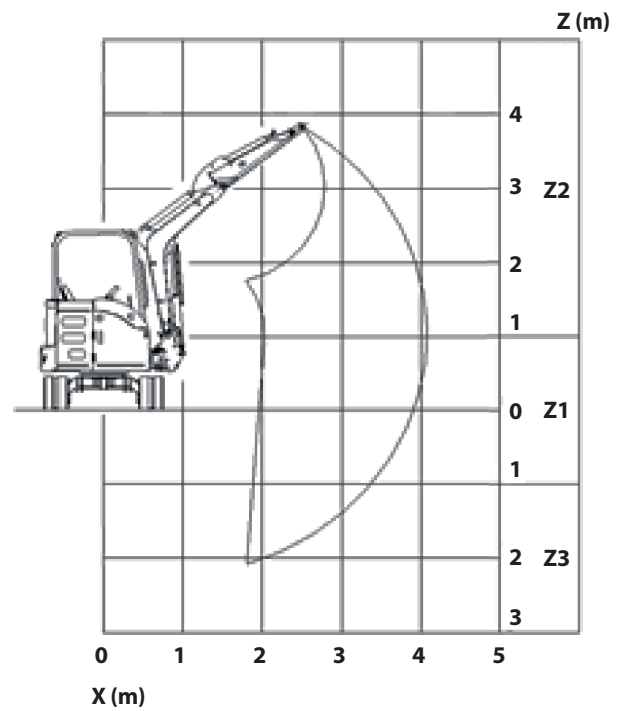

Arm		Z \ X		1    2    3    4				Unit; kg	
								MAX	REACH [m]
1.30 m	Z2			390	240	250	4.07		
	Z1		650	370		250	3.90		
	Z3		660	360		320	3.35		







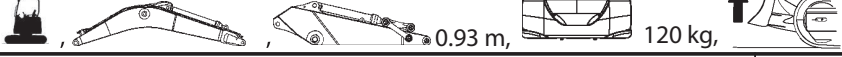



MABK-12-004-1 ja







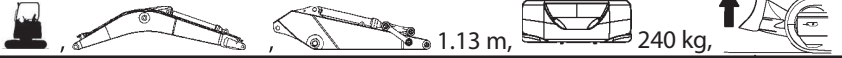
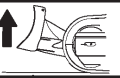

# SPECIFICATIONS

## Machine Capacities









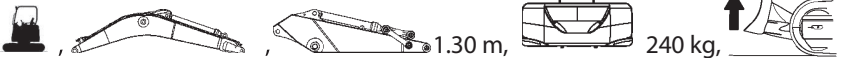
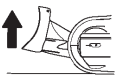

ZX17U-6  0.93 m, 120 kg, 



B	A						D		E
	1		2		3				
2									2.98
1			430	400	240	220	210	200	3.27
0			400	380	230	210	210	200	3.15
-1	1120*	1120*	400	380			280	270	2.58







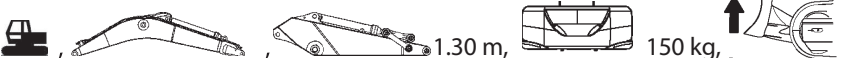



ZX19U-6  1.13 m, 240 kg, 

B	A						D		E
	1		2		3				
2									3.18
1			530	490	290	270	240	220	3.44
0			490	460	280	260	240	230	3.34
-1	940*	940*	490	450			300	290	2.81

ZX26U-6  1.30 m, 240 kg, 

B	A								D		E
	1		2		3		4				
2											3.93
1					540	400			350	260	4.07
0					510	370	330	240	320	230	3.90
-1	1680*	1680*	910	630	490	350			330	240	3.35
-2			890*	680					420	300	2.01

ZX26U-6  1.30 m, 150 kg, 

B	A								D		E
	1		2		3		4				
2											3.93
1					570	420			360	270	4.07
0					530	390	340	250	330	250	3.90
-1	1680*	1680*	950	650	510	370			350	250	3.35
-2			890*	700					430	320	2.01

# OPTIONAL ATTACHMENTS AND DEVICES

## Hydraulic Breaker, Hydraulic Crusher and Quick Couple

---

### Hydraulic Breaker, Hydraulic Crusher and Quick Couple

#### **Selecting a breaker or crusher**

When mounting a hydraulic breaker, crusher or quick hitch (coupler) on the mini excavator, it is necessary to consider the stability of the base machine, as well as requirements of the breaker, crusher or quick hitch, such as oil pressure and amount.

When selecting a hydraulic breaker or crusher, consult your authorized dealer.

#### **Precautions for Operation**

When using a hydraulic breaker, crusher or quick hitch (coupler), do so according to the instruction manual "Hydraulic Breakers, Crushers and Quick Hitches (Couplers)."

Follow the precautions to avoid damage to the body of the machine or to the breaker, crusher or quick hitch (coupler).

#### **Precautions for connecting breaker, crusher or quick coupler piping**

Take care when connecting/disconnecting the hoses of hydraulic breaker, crusher or quick hitch (coupler) to the pipes at the end of the arm so no dirt or debris gets on or inside hoses or pipes.

When a hydraulic breaker, crusher or quick hitch (coupler) is not attached to the machine, always put a cap or plug on the ends of the pipes at the end of arms and the ends of hoses of the breaker, crusher or quick hitch (coupler), to avoid dirt/debris from getting on or in them.

Always keep spare caps and plugs in the tool box, so they will not be lost.

Prior to starting work, check for looseness of bolts on the clamps holding pipes and for oil leaks from connections of pipes and hoses.

# OPTIONAL ATTACHMENTS AND DEVICES

## Attachment

### Attachment

#### Allowable Weight Limits of Installed Attachments

 **WARNING**

- The stability of the machine varies when an attachment other than the standard bucket is mounted on the mini excavator.
- If an attachment that is too heavy is attached, it results in not only poor workability, but also instability and danger.
- Do not attach any attachment to the mini excavator that exceeds the specified weight in terms of stability and its structure. Weights that can be attached are calculated according to the Ordinance on Industrial Safety and Health and these are posted in the operator's seat. However, use the table of attachment weights below as a guide when selecting attachments in terms of their workability.
- The allowable load of the structure (ROPS) that protects the operator may be exceeded, depending on the specification of the base machine and the attachment being attached; this presents the risk that the structure cannot guarantee the protection of the operator. Refer to the ROPS certificate posted in the operator's seat for the maximum allowable operating weight.

Model	Arm (m)	Undercarriage Width (m)	Breaker		Crusher/ Pulverizer		
			Std. Weight(kg)	Max Weight(kg)	Std. Weight(kg)	Max Weight(kg)	
ZX17U-6	0.93	980	70	80	90	100	
		1280	130	140	150	180	
ZX19U-6	1.13	980	90	100	110	130	
		1280	150	160	180	210	
ZX26U-6	CANOPY	1.30	1500	150	170	180	210
	CAB			160	180	190	230

- When working with a breaker mounted, the front operates more quickly than when working with a crusher, as it is lighter than the crusher.
- Avoid using attachments with an extremely long overall length as it may cause damage to parts of the front end of the mini excavator.
- When an attachment at maximum weight is attached, work in the front/rear of the machine. Also, avoid full deflection of levers.
- The crusher is heavier than the breaker, so operate levers more slowly.

# OPTIONAL ATTACHMENTS AND DEVICES

## Piping for Breaker and Crusher

### Piping for Breaker and Crusher

#### Operational Procedures for Stop and Selection Valves

##### A-Selection Valve

Remove the rubber cap and switch the attachment to use.

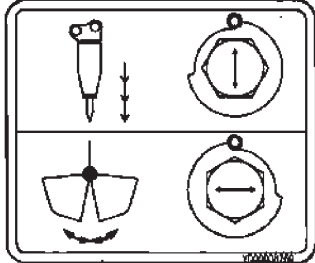

ZX17U-6,19U-6

MABK-13-002 ja

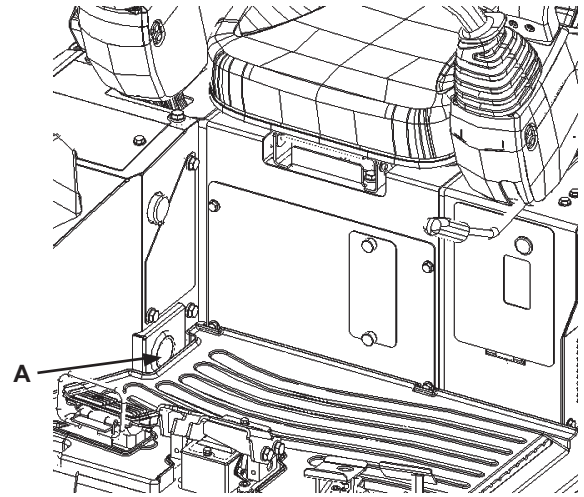

ZX17U-6,19U-6

MABA-07-037-2 ja

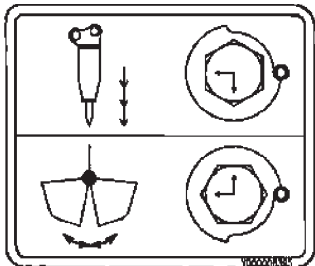

ZX26U-6

MABK-13-003 ja

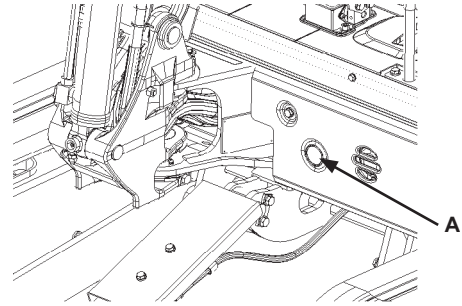

ZX26U-6

MABA-00-002-1 ja

# OPTIONAL ATTACHMENTS AND DEVICES

## Piping for Breaker and Crusher

### Stop Valves B and C

Stop Valves B and C	
1 (Closed)	When mounting/removing attachments and when not in use
2 (Open)	When using an attachment

Wrench Size: 24 mm

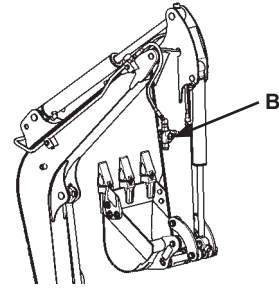

MABA-13-010-1 ja

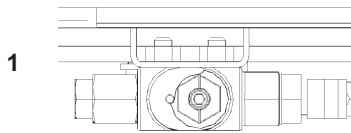

Stop Valve (Closed)

MABA-13-008-1 ja

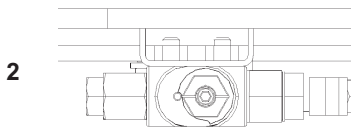

Stop Valve (Open)

MABA-13-009-1 ja

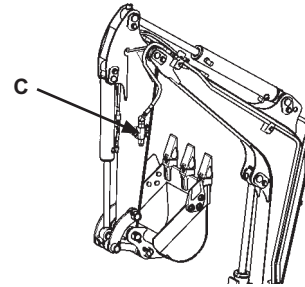

MABA-13-011-1 ja

### Pedal Operation and Hydraulic Oil Flow

Pressing the pedal towards D makes the oil flow to line B.  
Pressing the pedal towards E makes the oil flow to line C.

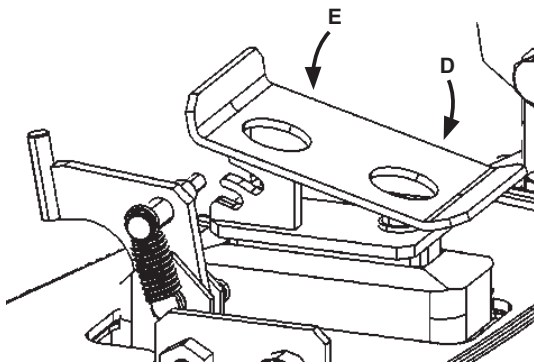

MABA-13-003-1 ja



## OPTIONAL ATTACHMENTS AND DEVICES

### Attachment Pedal (Hydraulic Breaker) (Optional)

#### Attachment Pedal (Hydraulic Breaker) (Optional)

Operation of a hydraulic breaker is performed with attachment pedal (2) at the left front of the operator's seat as shown in the diagram at right.

#### CAUTION

**Keep feet off attachment pedal (2) when it is not being operated.**

1. Lower lock (1) of attachment pedal (2) forward.
2. Depress attachment pedal (2) forward to operate the breaker.
3. Removing the foot from attachment pedal (2) stops the breaker.
4. Depressing attachment pedal (2) forward and locking it makes the breaker operate continuously.
5. Locking attachment pedal (2) in neutral keeps it in a state so it cannot be operated. Lock it in neutral when not operating the breaker.

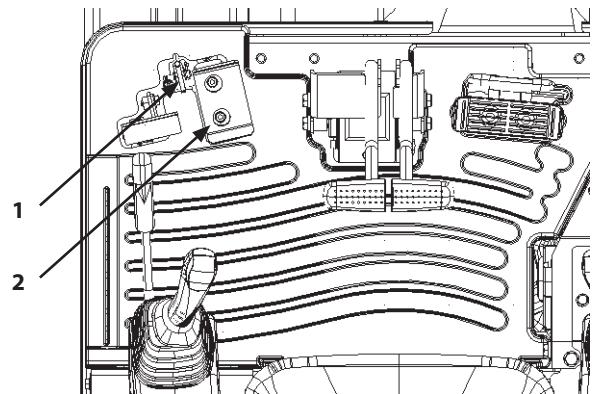

MABA-13-001-1 ja

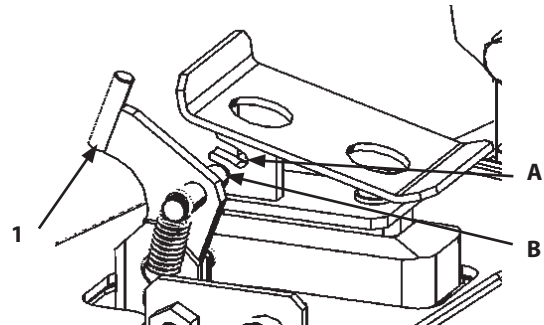

A: Forward LOCK Position  
B: Neutral LOCK position

MABA-13-002-1 ja

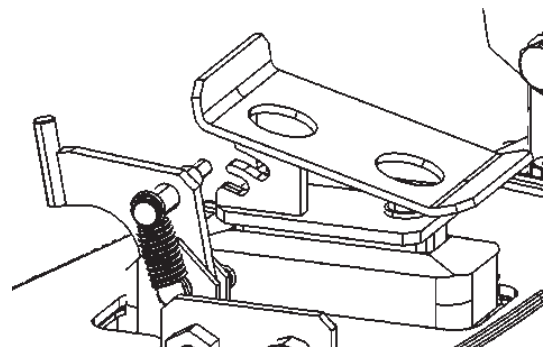

When Unlocked

MABA-13-003 ja

# OPTIONAL ATTACHMENTS AND DEVICES

## Precautions for Breaker Operation

### Precautions for Breaker Operation

#### **⚠ WARNING**

The hydraulic breaker is heavy, which makes it less stable than when using a bucket. When working with a hydraulic breaker mounted, the machine is more prone to tipping over. Note that it is also extremely dangerous because materials go flying, such as sand and fragments of rock and metal. In addition to safety measures to prevent turning over and to protect from flying debris, follow the precautions below and work safely.

#### **Avoid hitting objects with breaker.**

Hydraulic breakers are heavier than buckets, so they drop faster and require caution for this reason. If a hydraulic breaker crashes into crushed material, it will damage the front and/or upperstructure of the machine. Before starting breaker work, always move the breaker slowly so the tip of the chisel touches the object to be crushed.

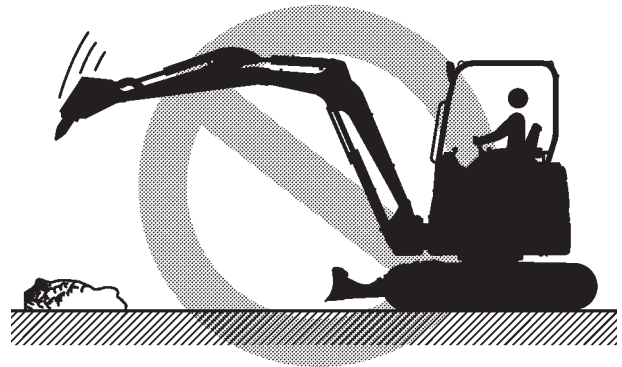

MZX5-13-001 ja

#### **Avoid moving objects with breaker.**

Do not move crushed materials or the like with the hydraulic breaker. In particular, do not use swiveling force to move crushed materials. Doing so may cause damage to the boom and/or arm, as well as the hydraulic breaker.

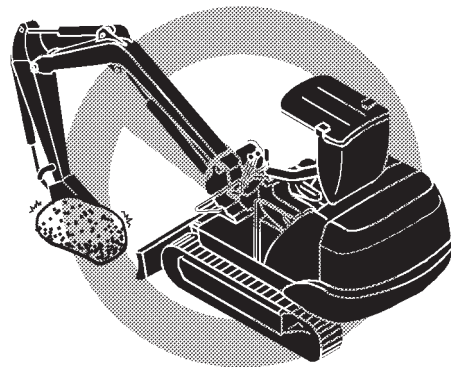

MZX5-13-002 ja

#### **Avoid operating breaker at cylinder stroke end**

Leave at least 50 mm of room at the end of the stroke of the machine's cylinders when striking with it. Striking with cylinders at the end of their stroke will cause damage to the cylinders, arm and/or boom.



MZX5-13-003 ja

## OPTIONAL ATTACHMENTS AND DEVICES

### Precautions for Breaker Operation

#### Stop operation if breaker hydraulic hoses jump abnormally.

When a hydraulic hose (1) shakes abnormally, continuing to use it as-is results in massive shock, damage to the pump and a negative impact on the machine.

Immediately consult the nearest Hitachi representative.

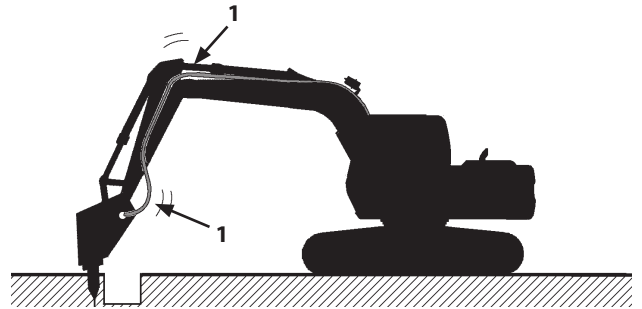

MABL-13-001-1 ja

#### Do not operate the breaker in water.

Doing so causes rust on the hydraulic breaker and damage to the seals.

As such, rust, debris and water may get into the hydraulic oil, which will cause damage to the machine's hydraulic equipment.



MZX5-13-017 ja

#### Do not use breaker for lifting operation.

Using a hydraulic breaker for sling loading is prohibited.

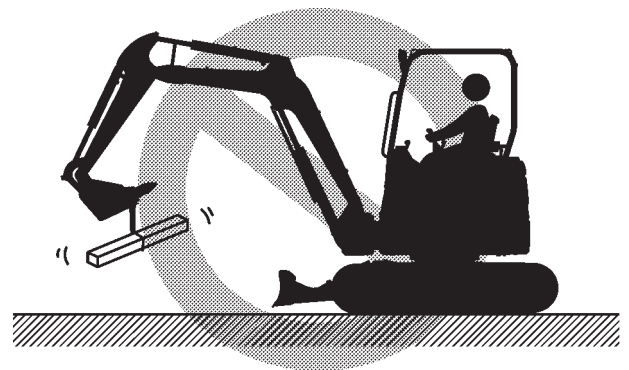

MZX5-13-004 ja

## OPTIONAL ATTACHMENTS AND DEVICES

### Precautions for Breaker Operation

#### **Do not operate the breaker to the side of the machine.**

Do not do any work while facing the side of the machine. Doing so may cause the machine to tip over and decrease the life of the undercarriage.

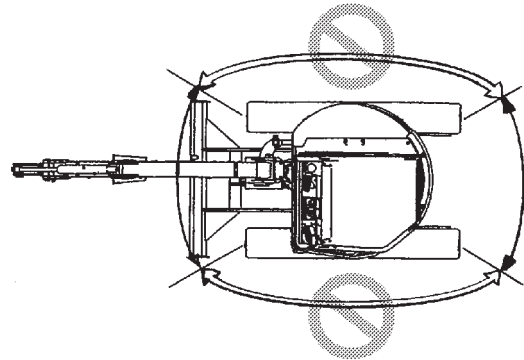

MZX5-13-005 ja

#### **Operate the chisel carefully to avoid hitting the machine.**

Be careful when crowding the hydraulic breaker as its chisel may hit the boom.



M1M7-05-023-2 ja

#### **Do not operate breaker with the arm positioned vertically.**

This results in strong vibrations on the arm cylinder, which will cause oil leaks.



MZX5-13-006 ja

## OPTIONAL ATTACHMENTS AND DEVICES

### Precautions for Breaker Operation

**Press the breaker so that the chisel (the axis) is positioned and thrust perpendicular to the object.**

Failure to do so causes damage to the chisel and/or scoring of pistons.

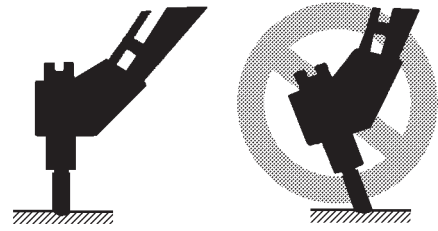

MZX5-13-007 ja

**Do not operate the breaker continuously for longer than one minute.**

Pounding too long causes abnormal wear of the chisel. If an object fails to crack within 1 minute, change the point the chisel is touching.

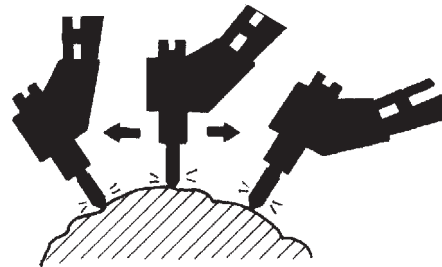

M147-05-015-2 ja

**Raising the front part of the undercarriage by pressing down with the breaker may cause damage to the front attachment.**

Do not press on anything with the breaker and lift the front of the undercarriage more than 150 mm.

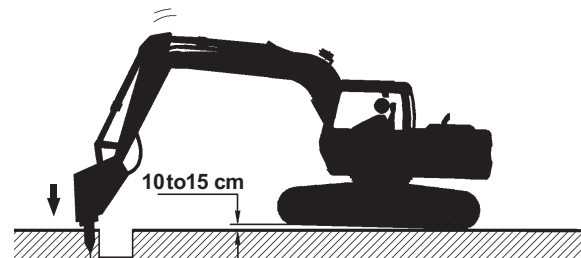

M147-05-016-2 en\_GB

**Do not operate the breaker with the boom swung**

Do not use the breaker for a long time with the boom swung. Doing so may decrease the life of the machine's frame.

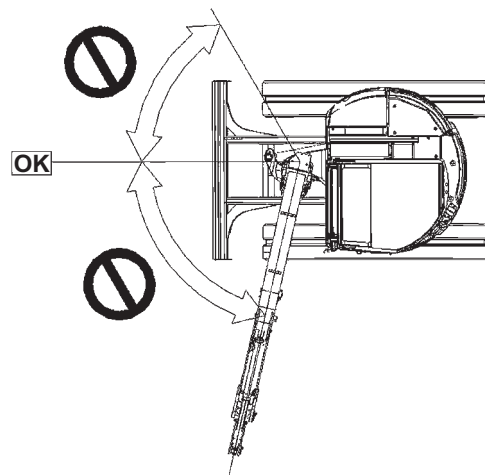

MADB-13-044-2 ja

## OPTIONAL ATTACHMENTS AND DEVICES

### Attachment Pedal (Hydraulic Crusher) (Optional)

#### Attachment Pedal (Hydraulic Crusher) (Optional)

Operation of a crusher is performed with attachment pedal (2) at the left front of the operator's seat as shown in the diagram at right.

#### **CAUTION**

**Keep feet off attachment pedal (2) when it is not being operated.**

1. Lower lock (1) of attachment pedal (2) forward.
2. Depress attachment pedal (2) forward/backward to operate the crusher.
3. Removing the foot from attachment pedal (2) stops the crusher.
4. Locking attachment pedal (2) in neutral keeps it in a state so it cannot be operated. Lock it in neutral when not operating the crusher.

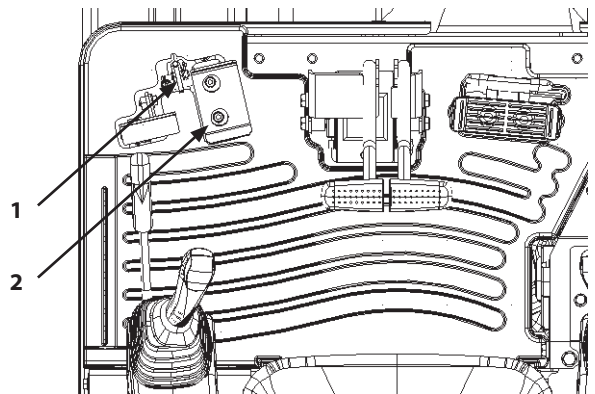

MABA-13-001-1 ja

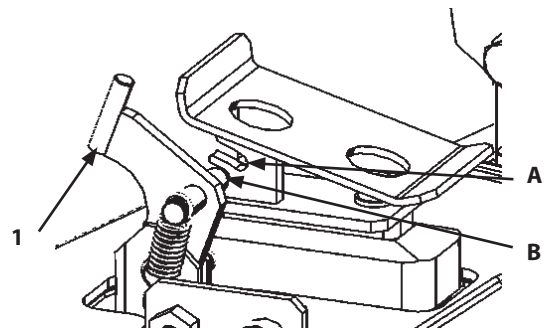

A: Forward LOCK Position  
B: Neutral LOCK position

MABA-13-002-1 ja

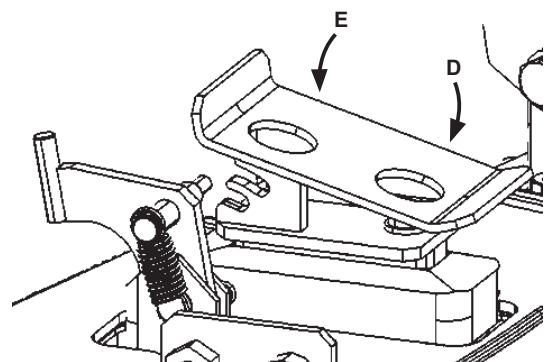

When Unlocked

MABA-13-003-1 ja

# OPTIONAL ATTACHMENTS AND DEVICES

## Precautions for Crusher Operation

### Precautions for Crusher Operation

Heed the following points to avoid damage to the front-end and to prevent the machine from tipping over.

#### WARNING

**When working with a crusher mounted, the machine becomes less stable because the attachment is heavy; this is the opposite of when using a bucket. It is extremely hazardous due to crushed material falling and scattering and the potential to tip over. In addition to normal safety measures, follow the precautions below and work safely.**

- Do not lift the machine when the bucket cylinder is in its fully extended or retracted positions. Doing so may damage parts of the front. The bucket cylinder is particularly susceptible to damage when fully extended. Be particularly careful during work like demolition of foundations with a crusher.
- Do not lift the machine when the arm cylinder is fully extended. Doing so will damage the arm cylinder.
- Do not make abrupt start or stop operations with the front-end when a heavy attachment like a crusher is mounted on it. Doing so may damage parts of the front.
- Work in the forward/reverse direction of the tracks. Working lateral to the track makes the machine unstable and may cause it to tip over.



MZX5-13-008 ja



MZX5-13-009 ja



## OPTIONAL ATTACHMENTS AND DEVICES

### Precautions for Crusher Operation

- Be careful when rolling in the crusher as it may hit the boom or the cab.

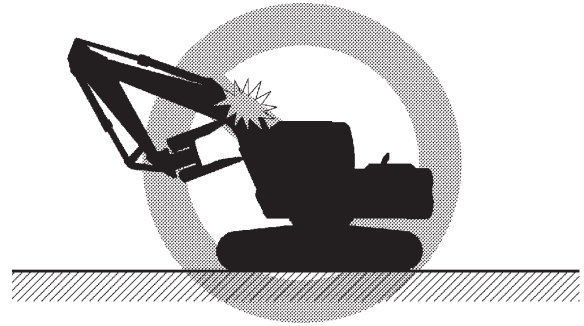

MZX5-13-010-2 ja

- When crushing high places with the boom fully lifted, take care that crushed material does not fall on the machine.



MZX5-13-011 ja

- Before working on the floor of a building, check and make sure it is strong enough to take the load from doing crusher work and of the machine itself. Some working methods result in a greater load on the floor than the machine's own weight.
- Keep the body horizontal and stabilize its footing while working. Do not drive onto glass or work on a slope.
- Do not use the crusher to move or load crushed materials.
- To prevent the attachment from collapsing, use a stand when changing attachments or when removing one.
- Hydraulic oil tends to get contaminated when changing attachments, such as crusher and bucket, or hydraulic breaker and another attachment. Change the hydraulic oil and full-flow filter element at the same frequency (hours) as the hydraulic breaker.
- Remove the crusher from the machine during transport. Do not leave the bucket cylinder fully extended during transport, as the vibration during transport may damage the front.

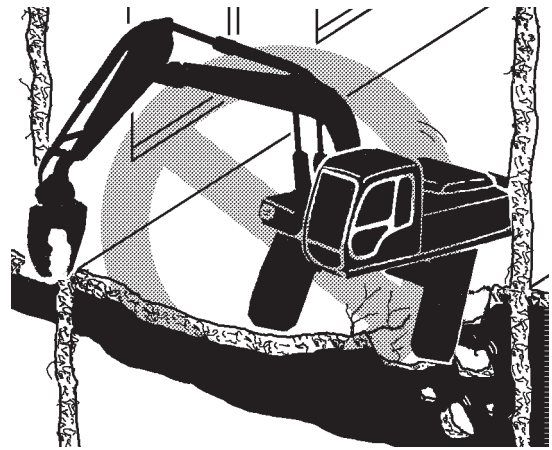

MZX5-13-012 ja



# OPTIONAL ATTACHMENTS AND DEVICES

## AUX Function Lever for Extra Piping 1 (Optional)

### AUX Function Lever for Extra Piping 1 (Optional)

#### **⚠ WARNING**

- These switches are provided for operating attachments of this machine. Do not use for any other purpose or alter their performance or shape of these switches as doing so may lead to serious personal injury and/or death.
- Before using these switches, thoroughly read the operation manual of the attachment concerned and check the operation of each function in a safe area.
- Before operating an attachment with this switch, confirm the requirements for safe and proper mounting and operation of the attachment with its manufacturer or distributor and observe them.

Auxiliary line 1 can be operated via the switches provided on right control lever (1), as illustrated.

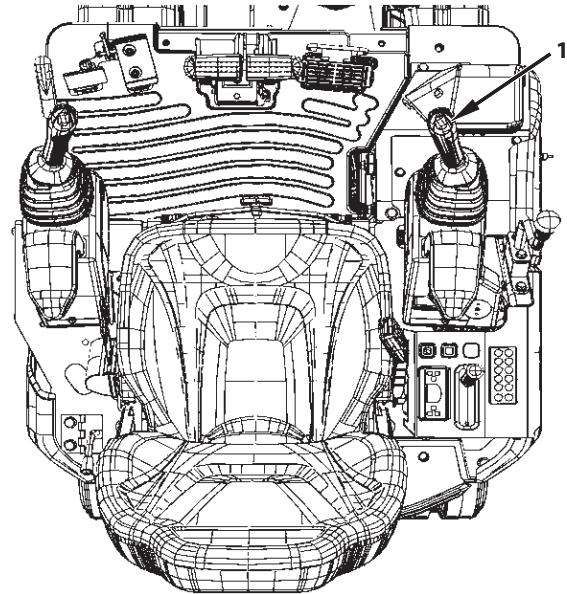

MABA-05-001-3 ja

#### **AUX Function Lever (Right) --- for Extra Piping 1**

1. Attachment such as a breaker can be operated by moving slide switch (2) on right control lever (1) left and right.
2. Pushing switch (3) on right control lever (1) performs same function as moving slide switch (2) to the left end. (It is useful when operating a breaker.)  
When slide switch (2) and switch (3) are operated simultaneously, operation of switch (3) has a priority.

2. Auxiliary
3. Breaker Switch
4. Horn Switch

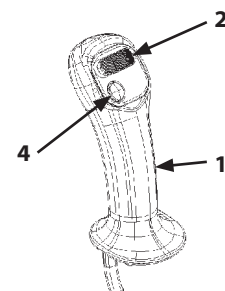

Right Control Lever

M1NE-05-002-1 ja

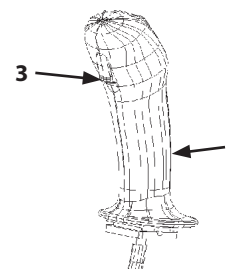

Right Control Lever

M1NE-05-003-1 ja

# OPTIONAL ATTACHMENTS AND DEVICES

## Numeric Keypad Lock (Optional)

### Numeric Keypad Lock (Optional)

#### Precautions for Use

- The handling of this system should be given all the care due a precision device.
- A word about passwords. The password can be set to whatever the customer desires, so the customer is responsible for managing the system. We recommend changing the password periodically. (To enhance and maintain the secrecy of the password) If the password is forgotten, consult the nearest Hitachi representative.
- Keep fire and cigarettes away from the keypad. Use a soft cloth when cleaning the surface of the keypad.
- If the machine will not be used for a long time, disconnect the battery cables to keep the battery from being drained.
- Do not use the machine if any maintenance has been neglected.

#### Description of Security Functions

This system allows the engine to be started only if the password entered matches the 4-digit password previously set by the customer.

#### Unlocking Method

1. Turn key switch (1) to the ON position and once all numeric keys (2) light, enter the password. The buzzer sounds and when unlocking indicator (3) (green LED) lights, the system unlocks and the engine can be started.

#### IMPORTANT

**Enter the password on numeric keypad (2) within 15 seconds once all the numeric keys (2) are lit. If not entered within that time, all the numeric keys (2) go out and nothing can be entered. In such case, turn key switch (1) OFF again and start from the beginning.**

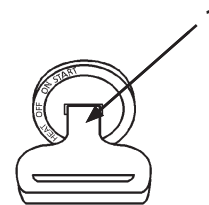

M1M7-01-007-5 ja

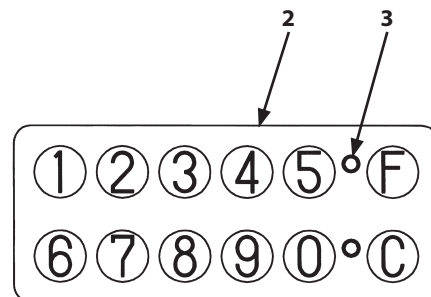

M1M7-OP1-01-001-1 ja

#### Locking

- After key switch (1) is turned OFF, the system locks automatically once the time set with the lock delay timer (user defined) elapses. Once the lock delay timer is active, the system can be locked immediately by pressing any button on the numeric keypad (1 to 9, 0, F, or C.) Also note that while the lock delay timer is active, unlocking indicator (3) flashes.

## OPTIONAL ATTACHMENTS AND DEVICES

### Numeric Keypad Lock (Optional)

#### Description of Numeric Keypad

1. Unlocking indicator (3) (green LED)  
When unlocking indicator (3) is flashing or lit, the engine can be started without entering the password. It lights when the 2nd digit of the password is entered.
2. Locking indicator (6) (red LED)  
Locking indicator (red LED) flashes slowly when locked. It lights when the 1st and 3rd digits of the password are entered.
3. Numeric keypad (2) (Numbers 1 to 9 and 0)  
Used for entering the password and making other settings.
4. F key (4)  
Used for setting functions.
5. C key (5)  
Mainly used for canceling input. It can also be used to display the number to check the password when it is changed.

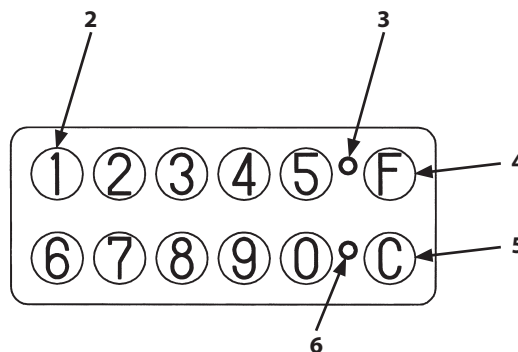

M1M7-OP1-01-001-2 ja

#### Unlocking Method

1. Turn key switch (1) to the ON position. All the LEDs of numeric keypad (2) light.
2. Enter the 1st digit of the 4-digit password.
3. Enter the 2nd digit in the same way.
4. Enter the 3rd digit in the same way.
5. Enter the 4th digit in the same way.
6. If the number entered matches the password, the buzzer sounds twice and the system unlocks. In such case, the engine can be started by turning key switch (1) to START.

#### NOTE

If a mistake in entering the password is noticed, press key C (3) to cancel the last number. Alternatively, turn key switch (1) OFF again and start from the beginning.

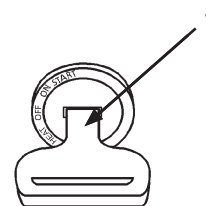

M1M7-01-007-5 ja

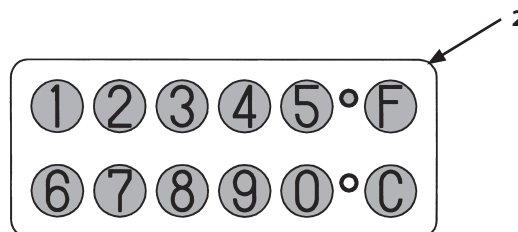

M1M7-OP1-01-002-1 ja

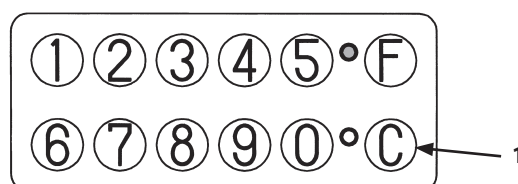

M1M7-OP1-01-003-1 ja

# OPTIONAL ATTACHMENTS AND DEVICES

## Numeric Keypad Lock (Optional)

### Change Password

Cancel the registered password and set a new one.

1. Turn key switch (1) to the ON position.
2. Unlock the system with the numeric keypad.

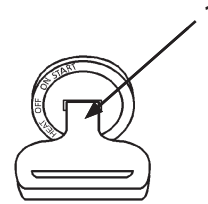

M1M7-01-007-5 ja

3. Press and hold key F (2) and key 1 (3) at the same time for 2 seconds or so.

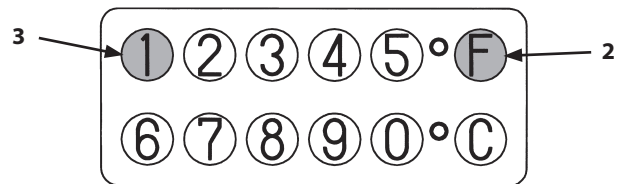

M1M7-OP1-01-004-1 ja

4. Both indicators (4) and (5) flash simultaneously and the buzzer sounds.
5. Enter the new 4-digit password to register. After entering it, both indicators (4) and (5) light and the buzzer sounds twice.
6. Enter the new password again to register it. (Same password as in step 5)  
If the new password is entered correctly, both indicators (4) and (5) flash and the numbers of the new password flash in order. After the numbers flash, the new password can be displayed again by pressing key C (6).

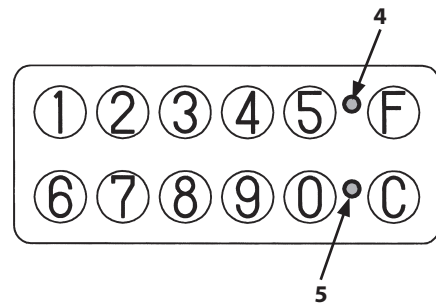

M1M7-OP1-01-005-1 ja

### IMPORTANT

**At this point the password is not yet registered.**

If the buzzer sounds 8 times and the two indicators (4) and (5) flash alternately, the password was not entered correctly. Start over from step 3.

7. Press and hold key F (2) for 2 seconds or so. The buzzer sounds 3 times, indicating the password is registered. The process is complete. It is active from the next time the password is input.

#### NOTE

When Key C (6) is pushed under the Change Password mode, the process starts from item 4. To terminate the Change Password process, turn key switch (1) OFF.

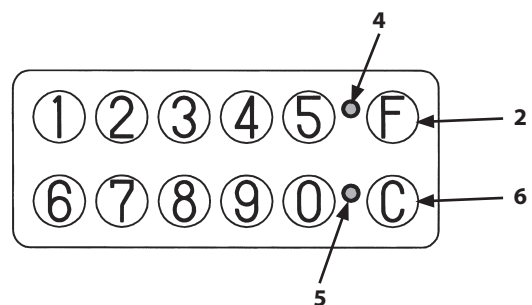

M1M7-OP1-01-005-2 ja

## OPTIONAL ATTACHMENTS AND DEVICES

### Numeric Keypad Lock (Optional)

#### Changing Lock Timer Setting

Changes the time in the lock delay timer.

1. Turn key switch (1) to the ON position.
2. Unlock the system with the numeric keypad.

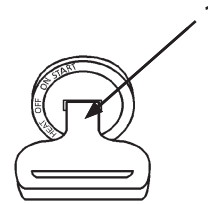

M1M7-01-007-5 ja

3. Press and hold key F (2) and key 2 (7) at the same time for 2 seconds or so.

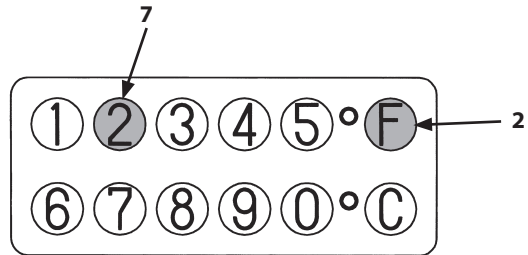

M1M7-OP1-01-006-1 ja

4. Both indicators (4) and (5) flash simultaneously and the buzzer sounds.
5. Enter the key on the numeric keypad that corresponds to the desired time for the lock delay timer.

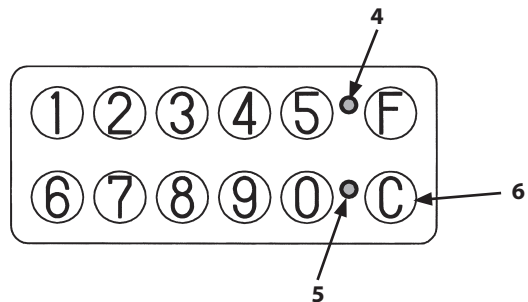

M1M7-OP1-01-005-3 ja

#### List of Timer Times

Key 1	:	15 seconds (Factory default)
Key 2	:	3 minutes
Key 3	:	5 minutes
Key 4	:	10 minutes
Key 5	:	15 minutes
Key 6	:	30 minutes
Key 7	:	60 minutes
Key 8	:	90 minutes
Key 9	:	120 minutes
Key 0	:	0 sec.

6. Press and hold key F (2) for 2 seconds or so. The buzzer sounds 3 times, indicating the lock delay timer time is registered.  
The process is complete.

#### NOTE

To stop partway through the process, press key C (6) or turn key switch (1) OFF.

## OPTIONAL ATTACHMENTS AND DEVICES

### Numeric Keypad Lock (Optional)

---

#### Alarm Function

This system sounds an alarm with the horn and buzzer if the wrong security code is entered 4 times in a row. They continue to sound for a predetermined time even if key switch (1) is turned OFF.

After that, the horn and buzzer continue sounding the alarm until the correct password is entered.

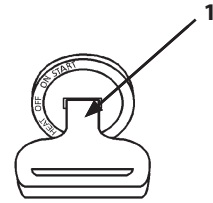

M1M7-01-007-5 ja

#### System Error Display

If the 2 indicators continue to flash alternately, it indicates a system error. Consult your authorized dealer

#### Factory Default Setting

The factory default settings are as follows.

- (1) Password  
0000
- (2) Lock delay timer setting  
15 seconds

## INDEX

- 
- A**
- A. Greasing..... 7-24
  - Adjust the Operator's Seat ..... S-6
  - Adjust Track Sag (Rubber Crawler) and Check for Damage..... 7-84
  - Adjusting the Seat ..... 1-19
  - Allowable Weight Limits of Installed Attachments..... 13-2
  - Alternator Indicator ..... 1-10
  - AM/FM Radio Operation (Cab equipped machine) ..... 1-14
  - Attachment..... 13-2
  - Attachment Pedal (Hydraulic Breaker) (Optional) 13-5
  - Attachment Pedal (Hydraulic Crusher) (Optional) ..... 13-10
  - AUX Function Lever for Extra Piping 1 (Optional)..... 13-13
  - Avoid Abusive Operation..... 5-12
  - Avoid Applying Heat to Lines Containing Flammable Fluids..... S-34
  - Avoid Colliding Blade Against Rocks..... 5-14
  - Avoid Colliding Boom Cylinder With Track..... 5-14
  - Avoid Heating Near Pressurized Fluid Lines..... S-34
  - Avoid High-Pressure Fluids..... S-30
  - Avoid Hitting Blade With Bucket..... 5-14
  - Avoid Injury from Attachment Falling Accident... S-28
  - Avoid Injury from Back-Over and Swing Accidents..... S-16
  - Avoid Power Lines ..... S-20
  - Avoid Tipping ..... S-18
- B**
- B. Engine..... 7-30
  - Battery..... 7-75
  - Battery Disconnect Switch ..... 1-23
  - Before Leaving the Machine..... 5-7
  - Before Starting the Engine ..... 3-2
  - Before Starting Work ..... 5-8
  - Beware of Asbestos and Silicon Dust and Other Contamination..... S-36
  - Beware of Exhaust Fumes..... S-33
  - Blade Lever ..... 5-3
  - Blade Pins (ZX26U-6)..... 7-26
  - Bleed Air From Hydraulic Circuits..... 7-46
  - Bleed Air from Hydraulic System..... 7-45
  - Bleeding Air from the Fuel System..... 7-61
  - Boom Cylinder may Hit Blade..... 5-13
  - Boom Swing Operation ..... 5-2
  - Boom Swing Pedal..... 5-2
  - Breaking in New Machine..... 2-1
  - Bucket Types and Applications..... 12-7
- C**
- C. Transmission..... 7-34
  - Change Bucket..... 7-83
  - Change Coolant..... 7-71
  - Change Hydraulic Oil..... 7-41
  - Check and Adjust Fan Belt Tension..... 7-68
  - Check and Adjust Injection Timing..... 7-89
  - Check and Replace Bucket Teeth..... 7-81
  - Check and Replace Seat Belt..... 7-88
  - Check Coolant Level..... 7-67
  - Check Crankcase Breather..... 7-90
  - Check Engine Oil Level..... 7-30
  - Change Engine Oil..... 7-31
  - Check Fuel Level..... 7-59
  - Check Fuel Hoses..... 7-64
  - Check Hoses and Lines..... 7-53
  - Check Hydraulic Oil Level..... 7-39
  - Check Instruments After Starting Engine..... 3-5
  - Check Radiator Cap..... 7-90
  - Check Starter and Alternator..... 7-89
  - Check the Hour Meter Regularly..... 7-1
  - Check Water Separator..... 7-60
  - Check, Clean and Function Check of Injection Nozzle..... 7-89
  - Clean and Replace Air Cleaner Element..... 7-65
  - Clean Cab Floor (ZX26U-6) (Cab equipped machine)..... 7-88
  - Clean Radiator/Oil Cooler Core..... 7-73
  - Cleaning the Suction Filter..... 7-41
  - Confirm Direction of Machine to Be Driven ..... S-12
  - Connecting Booster Cables ..... 3-6
  - Control Lever (ISO Pattern) ..... 5-1
  - Control Lever Universal Joint..... 7-29
  - Converting the Track..... 7-87
  - Coolant Changing Procedures..... 7-72
  - Coolant Temperature Indicator ..... 1-11
  - Correct Maintenance and Inspection Procedures... 7-1
- D**
- D. Hydraulic System..... 7-36
  - Deletion of Preset Memory ..... 1-15
  - Dig with Caution ..... S-19
  - Digital Clock Setting Procedure ..... 1-16
  - Disconnecting the Booster Cables ..... 3-7
  - Dispose of Waste Properly ..... S-37
-

## INDEX

- 
- Door Lock Release Lever (ZX26U-6) (Cab equipped machine) ..... 1-17  
Drain Fuel Tank Sump..... 7-62  
Drain Hydraulic Oil Tank Sump..... 7-40  
Driving and Other Precaution ..... 5-16
- E**
- E. Fuel System.....7-58  
Electric Fans.....12-10  
Engine Oil Pressure Indicator ..... 1-11  
Ensure Safety Before Rising from or Leaving Operator's Seat .....S-6  
Escaping from the Emergency Exit (ZX26U-6) (Cab equipped machine)..... 1-20
- F**
- F. Air Cleaner..... 7-65  
Fasten Your Seat Belt .....S-6  
Fastening the Machine for Transport.....6-4  
Follow Safety Instructions .....S-2  
Front Joint Pins..... 7-24  
Front Window..... 1-18  
Fuel Gauge ..... 1-11  
Fuel Level Indicator ..... 1-10
- G**
- G. Cooling System.....7-66  
Gear Oil in Travel Reduction Gear..... 7-34  
General Precautions for the Cab..... S-5  
Getting On and Off the Machine ..... 1-3  
Grading Operation..... 5-11
- H**
- H. Electrical System..... 7-74  
Handle Chemical Products Safely..... S-37  
Handle Fluids Safely—Avoid Fires ..... S-23  
Hood and Access Covers.....7-7  
Hour Meter ..... 1-11  
Hydraulic Breaker, Hydraulic Crusher and Quick Couple..... 13-1
- I**
- I. Miscellaneous..... 7-81  
Inspect and Adjust Valve Clearance..... 7-89  
Inspect Machine..... S-4  
Inspect Machine Daily Before Starting..... 3-1  
Intended Use.....1
- J**
- Jump Starting..... S-8
- K**
- Keep People Clear from Working Area .....S-17  
Keep Riders off Machine ..... S-8  
Key Switch ..... 1-8  
Kind of Oils..... 7-20
- L**
- Lifting Application.....S-21  
Lifting Capacities..... 12-12  
Lifting Capacities and Machine Capacities..... 12-11  
Lifting the Machine..... 6-7  
List of Consumable Parts.....7-23  
Loading..... 6-2  
Loading/Unloading on a Truck.....6-1  
Lowering the Boom in Emergencies and if the Engine Stops .....5-20
- M**
- Maintenance Guide.....7-15  
Maintenance Guide Table..... 7-3  
Maintenance Under Special Environmental Conditions..... 9-1  
Measure Engine Compression Pressure..... 7-89  
Monitor Panel ..... 1-9
- N**
- Name of Components ..... 1-1,1-5,1-6  
Never Drive Bucket Teeth Into the Ground..... 5-12  
Never Position the Bucket Over Anyone ..... S-17  
Never Ride Attachment..... S-37  
Never Swing the Machine or Boom to Work.....5-12  
Never Undercut a High Bank ..... S-19  
Never use as a Hammer..... 5-13  
Never Use Other than as Specified ..... 5-18  
Noise Level Results(2000/14/EC)(2006/42/EC).... 12-10  
Numeric Keypad Lock (Optional)..... 13-14
- O**
- Opening and Closing Radiator Front Cover.. 7-13,7-14  
Opening and Closing the Engine Cover ZX17U-6, 19U-6..... 7-7  
Opening and Closing the Engine Cover ZX26U-6... 7-9  
Opening and Closing the Tank Cover ZX17U-6, 19U-6 .....7-11  
Opening and Closing the Tank Cover ZX26U-6 .... 7-12  
Operate Only from Operator's Seat..... S-7
-



## INDEX

- 
- Operate with Caution ..... 5-19
- Operating Backhoe..... 5-10
- Operating in Water or Mud ..... 4-10
- Operation of the Side Frame Extend/Retract  
Lever ..... 5-5
- Operational Procedures for Stop and Selection  
Valves..... 13-3
- Operator's Seat Fore-Aft Adjustment..... 1-19
- Overheat Indicator ..... 1-11
- P**
- Parking ..... 4-13
- Parking the Machine on Slopes..... 4-13
- Part Name and Function ..... 1-14
- Pedal Operation and Hydraulic Oil Flow..... 13-4
- Periodic Replacement of Parts..... 7-19
- Pilot control shut-off lever ..... 5-7
- Piping for Breaker and Crusher..... 13-3
- Precautions for After Operations ..... 5-23
- Precautions for Blade Operation..... 5-4
- Precautions for Breaker Operation..... 13-6
- Precautions for Communication Termina ..... 5-37
- Precautions for connecting breaker, crusher or  
quick coupler piping..... 13-1
- Precautions for Crusher Operation..... 13-11
- Precautions for Handling Accumulator and Gas  
Damper ..... 5-35
- Precautions for Installing Wide Bucket or  
Special Type Bucket..... 5-15
- Precautions for Lightning ..... 5-20
- Precautions for Operation..... 13-1
- Precautions for Operations ..... 5-9
- Precautions for Traveling on Slopes..... 4-11
- Precautions for Welding and Grinding ..... 5-34
- Preheat Indicator ..... 1-10
- Preparation for Inspection and Maintenance ..... 7-6
- Prepare for Emergencies ..... 5-3
- Prevent Burns..... 5-29
- Prevent Fires..... 5-31
- Prevent Parts from Flying..... 5-28
- Procedure for Stopping the Engine ..... 3-8
- Protect Against Flying Debris and Falling Object. 5-22
- Protect Against Noise..... 5-4
- Q**
- Quick Coupler..... 7-55
- R**
- Radio (ZX26U-6) (Cab equipped machine)  
(Optional) ..... 1-13
- Radio Operation ..... 1-14
- Raising One Track Using the Boom and Arm ..... 4-8
- Recognize Safety Information ..... 5-1
- Remove Paint Before Welding or Heating..... 5-35
- Removing and Storing Lower Front Window ..... 1-18
- Replace --- after cleaning 6 times or after one  
year..... 7-65
- Replace Engine Oil Filter..... 7-31
- Replace Fuel Main Filter Element..... 7-63
- Replace Full-Flow Filter..... 7-47
- Replace Pilot Oil Filter Element..... 7-50
- Replace Rubber Crawler..... 7-86
- Replace Rubber Hoses Periodically..... 5-29
- Replacement of Fuses..... 7-80
- Restriction of Attachment Installation..... 5-11
- Room Lamp (ZX26U-6) (Cab equipped machine) 1-22
- S**
- Seat Back Box ..... 1-19
- Seat Belt ..... 1-21
- Selecting a breaker or crusher..... 13-1
- Side Frame Extend/Retract Lever (ZX17U-6,  
19U-6) ..... 5-5
- Sound Adjustment ..... 1-16
- Specifications ZX17U-6..... 12-1
- Specifications ZX19U-6..... 12-2
- Specifications ZX26U-6..... 12-3
- Starting in Cold Weather ..... 3-4
- Starting the Engine..... 3-3
- Station Presetting Procedure ..... 1-15
- Stopping the Engine..... 3-8
- Storing the Machine..... 10-1
- Support Machine Properly..... 5-27
- Swing Bearing..... 7-27
- Swing Internal Gear..... 7-28
- Switch Operation ..... 1-24
- Switch Panel ..... 1-8
- T**
- Tightening and Retightening Torque of Bolts  
and Nuts..... 7-91
- Towing the Machine ..... 4-9
- Transporting by Road..... 6-1
- Transporting Rubber Crawler-Equipped Machines 6-4
- Travel Lever (ZX17U-6, 19U-6) ..... 4-1
- Travel Levers and Pedals (ZX26U-6) ..... 4-3
- Travel Mode Pedal ..... 4-5
- Travel Mode Switch ..... 4-6
- Traveling..... 4-7
- Traveling on Soft Ground..... 4-8
-

## INDEX

---

Tuning Procedure ..... 1-15

### U

Understand Signal Words.....S-1  
Unloading..... 6-6  
Use Handholds and Steps..... S-5  
Use the Right Shoes for the Site..... 5-15  
Using Booster Battery..... 3-6  
Using Rubber Crawler..... 5-16  
Using the Front Window (ZX26U-6) (Cab  
equipped machine) ..... 1-18  
Using the Heater (ZX26U-6) (Cab equipped  
machine) ..... 1-12

### W

Warming Up in Cold Weather..... 5-9  
Warming-Up Operation..... 5-9  
Wear Protective Clothing.....S-3  
When Extending the Blade Width: ..... 5-6  
When Retracting Blade Width: ..... 5-6  
When using high performance element..... 7-47  
Working Ranges ZX17U-6..... 12-4  
Working Ranges ZX19U-6..... 12-5  
Working Ranges ZX26U-6..... 12-6

### Z

ZX17U-6..... 12-7  
ZX19U-6..... 12-8  
ZX26U-6..... 12-9

# CONFORMITY

---

## EU Declaration of Conformity\*

### Manufacturer;

Hitachi Construction Machinery (Europe) N.V.

- Amsterdam  
Siciliëweg 5, 1045 AT, Amsterdam, The Netherlands
- Oosterhout  
Souvereinstraat 16, 4903 RH, Oosterhout, The Netherlands  
Hitachi Construction Machinery Co.,Ltd.
- Tokyo  
16-1, Higashi ueno 2-chome, Taito-ku, Tokyo, Japan
- Tsuchiura  
650 Kandatsu-machi, Tsuchiura-shi, Ibaraki, Japan

### Position and address of the person authorised to compile the technical file

General Manager, Engineering  
Siciliëweg 5, 1045 AT, Amsterdam, The Netherlands

### Legal Provisions;

Herewith we declare that the machine is in conformity with the relevant provisions of:

ZX17U-6/19U-6 2014/30/EU EMC Directive  
2006/42/EC Machine Directive  
2000/14/EC Outdoor Noise Directive

ZX26U-6 2014/53/EU Radio Equipment Directive  
2006/42/EC Machine Directive  
2000/14/EC Outdoor Noise emission Directive

### Notified body for 2000/14/EC

TüV SÜD Industrie Service GmbH  
Westendstraße 199, 80686 München, Germany  
**Conformity assessment procedure followed;** Annex VI

The EU Declaration of Conformity will lose its validity for any modification of the machine without approval.

\*The EU Declaration of Conformity includes the machine without accessory, unless fitted with accessories approved by Hitachi Construction Machinery.

---

### Engine Importer information

The engine was placed on the EU market by:  
Hitachi Construction Machinery (Europe) NV  
Souvereinstraat 16, 4903RH Oosterhout, The Netherlands

---

## CONFORMITY

### Vibration levels

The level of vibrations transmitted from the machine to the operator depends mainly upon the ground conditions on which the operations take place, the mode of operation of the machine and the equipment used. Exposure to vibrations can be considerably reduced when taking into account the following recommendations:

- Select the right type and size of machine. Use equipment and tools compatible with the machine and suitable for the type of work to be done;
- Adjust the seat to the weight and size of the operator and lock the seat in the correct position;
- Inspect regularly the suspension of the seat. Adjust and repair if necessary;
- Perform maintenance of the machine at the prescribed intervals;
- Operate the equipment in a smooth way, preventing, as far as possible, aggressive movements or excessive loads;
- Adapt travelling speed and –route if necessary and avoid, as far as possible, rough terrain or hitting obstacles to prevent bouncing.
- Keep the terrain in good condition. Remove large obstacles and fill any ditched and holes.

The average acceleration value to which the operator's arms are subjected does not exceed  $2.5 \text{ m/s}^2$ .

The average acceleration value to which the operator's body is subjected does not exceed  $0.5 \text{ m/s}^2$ .

The results were obtained using an accelerometer during excavating operations.

### Note:

The vibration exposure values have been determined under particular operating and terrain conditions and therefore may not be representative for all possible operating conditions within the intended use of the machine.

Consequently, this single Whole-Body vibration emission value is not intended to determine the Whole-Body vibration exposure as required by European Directive 2002/44/EC.

For this purpose it is recommended to conduct measurements under actual working conditions. If this is not feasible, information provided in the table below, taken from ISO/TR 25398:2006(\*1), to estimate the daily vibration exposure is recommended.

For regular operating activities, use the typical vibration levels as the estimated level.

With an experienced operator and/or smooth terrain, subtract the standard deviation from the typical vibration level in order to obtain the estimated vibration level.

For aggressive operations and/or rough terrain, add the standard deviation to the typical vibration level in order to obtain the estimated vibration level.

Operating activity	Typical vibration level [ $\text{m/s}^2$ ]			Standard deviation [ $\text{m/s}^2$ ]		
	$1.4 \cdot a_{w,eqx}$	$1.4 \cdot a_{w,eqy}$	$a_{w,eqz}$	$1.4 \cdot s_x$	$1.4 \cdot s_y$	$s_z$
Excavating	0.33	0.21	0.19	0.19	0.12	0.10
Hydraulic breaker application	0.49	0.28	0.36	0.20	0.13	0.17
Travelling	0.45	0.39	0.62	0.17	0.18	0.28

(\*1) ISO/TR 25398:2006 Mechanical vibrations – Guidelines for assessment of exposure to whole-body vibration of ride-on machine – Use of harmonized data measured by international institutes, organizations and manufacturers.

## Hitachi Construction Machinery Europe N.V. (HCME) Limited Warranty

### **This limited warranty ("Warranty") applies only to the Product specified in this Operator's Manual.**

This Warranty applies only to the Product manufactured and/or sold by Hitachi Construction Machinery (Europe) N.V. ("HCME") or through its authorized Distributor in the European Union, Switzerland, Iceland and Norway.

This Warranty does not apply to the Product operating in the countries outside the European Union with the exception of Switzerland, Iceland and Norway. (In other areas different warranties may apply. Copies of applicable warranties may be obtained by written request to Hitachi Construction Machinery Co., Ltd.)

HCME warrants the new Product will comply in all material respects with HCME's specifications thereof and will be free of defects proved to have been caused by defective materials and/or faulty workmanship, in the sole judgment of HCME during the following period:

### **Warranty Period**

Twelve (12) months, unlimited hours of operation after the date of delivery to the first User.

### **This Warranty is subject to the following terms and conditions:**

#### **HCME's Obligations & Responsibilities**

- Repair the Product in the sole judgment of HCME;
- Repair or provide replacement parts in the sole judgment of HCME (either new, remanufactured, repaired or by HCME approved parts) needed to correct the defects;
- The replaced parts become the property of HCME;
- The replaced parts provided under this Warranty are warranted for the remaining Warranty Period applicable to the Product in which they were installed;
- Provide reasonable and customary labour necessary for the Warranty works through its authorized Distributor at the place of business of HCME or its authorized Distributor during normal working hours.

#### **User's Obligations & Responsibilities**

- Operate the Product in accordance with the Operator's Manual and the designated specification of fuel and perform the required maintenance as indicated in the Operator's Manual;
- Provide proof of a delivery inspection to the first User, periodical maintenance compliance (receipts, copies of work orders, invoices and periodical inspection results);
- Pay for travel expenses of HCME or HCME's authorized Distributor (as the case may be) to a job site and transportation expenses;
- Labour costs in excess of those provided under "HCME Obligations & Responsibilities" including but not limited to premium or overtime labour costs;
- Pay for parts shipping charges in excess of those that are considered usual or customary;
- Pay for local taxes and duties if applicable;
- Pay for costs to investigate complaints, unless the problem is caused by a defect in HCME material or workmanship;
- Give a prompt notice (within five (5) working days) of a warrantable failure and/or potential problem;

- Promptly make the Product available for Warranty works;
- Permit HCME and/or its authorized Distributor to get access to all relevant information in order to investigate and/or repair the failure.

### **Limitations**

This Warranty does not apply to service parts, wear parts, consumable parts such as lamps, fuses, V-belts, brake clutch lining, brake disc, clutch disc, ground engaging parts, track, tires, wire ropes, filter elements, oil, grease, grease nipples, etc., unless these parts fail as a result of a failure of a warranted part of the Product. Moreover, this Warranty shall not be applicable in the following cases:

- Failures resulting from unauthorized repair or adjustments in the Product;
- Failures resulting from the attachments, and/or parts, not manufactured and/or sold or approved by HCME;
- Failures resulting from using fuel and/or lubricant other than the type designated by HCME;
- Failures resulting from operation in disregard of the Operator's Manual and/or catalogues and/or such instructions as are issued by HCME for the Product;
- Failures resulting from any abuse, neglect, improper handling and/or insufficient or erroneous maintenance of the Product;
- Failures resulting from floods, lightning, storms, fires, and other Acts of God;
- Failures resulting from the User's delay in prompt repair of the initial problem;
- Failures resulting from any use and/or installation that HCME judges improper;
- Minor change of colour and/or rust on the Product ascribable to normal wear and tear;
- Such phenomena as normal noise, vibration, etc. which will not affect the function of the Product;
- Minor adjustments such as re-torque and tightening of nuts, bolts, hoses, hydraulic lines, fittings and troubleshooting.

THIS WARRANTY IS EXCLUSIVE AND IN LIEU OF ALL OTHER WARRANTIES AND THERE IS NO IMPLIED WARRANTY OF MERCHANTABILITY OR FITNESS FOR A PARTICULAR PURPOSE. THIS WARRANTY CONSTITUTES USER'S SOLE RIGHT AND REMEDY AND HCME'S SOLE OBLIGATIONS & RESPONSIBILITIES IN RESPECT OF ANY DEFECTIVE OR MALFUNCTIONING PRODUCTS AND IS SUBJECT TO ANY LIMITATIONS OF LIABILITY THAT ARE PART OF ANY SALES AGREEMENT WITH HCME.

FOR THE AVOIDANCE OF DOUBT AND WITHOUT PREJUDICE TO THE FOREGOING, HCME WILL NOT BE LIABLE FOR ANY DIRECT OR INDIRECT DAMAGES (INCLUDING BUT NOT LIMITED TO ANY CONSEQUENTIAL DAMAGES, LOSS OF REVENUES, LOSS OF PROFITS OR BUSINESS INTERRUPTION LOSSES) UNLESS THE DAMAGE IS THE RESULT OF HCME'S WILFULL MISCONDUCT OR GROSS NEGLIGENCE.

EXCEPT AS EXPRESSLY STATED HEREIN, THERE ARE NO WARRANTIES, EXPRESS OR IMPLIED, BY OPERATIONS OF LAW OR OTHERWISE, PERTAINING TO THE PRODUCTS.

This version is in effect as of October 1, 2014.

## **Hitachi Construction Machinery Europe N.V. (HCME) Limited Warranty**

---

IF THIS WARRANTY IS ALSO TRANSLATED INTO ANOTHER LANGUAGE, DIFFERENT FROM ENGLISH, IN CASE OF DISCREPANCIES BETWEEN THE TEXTS, THE TEXT IN ENGLISH LANGUAGE SHALL PREVAIL.

THIS WARRANTY SHALL BE GOVERNED BY AND IS CONSTRUED IN ACCORDANCE WITH THE LAW OF THE NETHERLANDS WITH THE EXCLUSION OF THE UN CONVENTION ON CONTRACTS FOR THE INTERNATIONAL SALE OF GOODS (CISG). ALL CLAIMS AND DISPUTES ARISING OUT OF OR IN CONNECTION WITH THIS WARRANTY SHALL BE SETTLED BY THE COMPETENT COURT IN AMSTERDAM, THE NETHERLANDS. HOWEVER, HCME SHALL HAVE THE RIGHT TO SUBMIT ANY CLAIM OR DISPUTE TO A COURT THAT WOULD HAVE JURISDICTION IN THE ABSENCE OF THE FOREGOING STIPULATION. AS AN EXCEPTION, IF THE USER IS DOMICILED OUTSIDE THE EUROPEAN UNION, SWITZERLAND, NORWAY OR ICELAND, UPON COMMENCEMENT OF PROCEEDINGS ALL CLAIMS AND DISPUTES ARISING OUT OF OR IN CONNECTION WITH THIS WARRANTY, SHALL BE FINALLY SETTLED IN ACCORDANCE WITH THE ARBITRATION RULES OF THE NETHERLANDS ARBITRATION INSTITUTE (NAI). THE ARBITRAL TRIBUNAL SHALL BE COMPOSED OF THREE ARBITRATORS WHO SHALL DECIDE IN ACCORDANCE WITH THE RULES OF DUTCH LAW. THE PLACE OF ARBITRATION SHALL BE AMSTERDAM, THE NETHERLANDS. THE ARBITRAL PROCEDURE SHALL BE CONDUCTED IN THE ENGLISH LANGUAGE.

Claims under this Warranty should be submitted to a place of business of an authorized HCME's Distributor or directly to HCME. For the information concerning either the address to submit the claims or HCME as the issuer of this Warranty, please write to: Hitachi Construction Machinery (Europe) N.V., Sicilieweg 5, 1045 AT, Amsterdam, The Netherlands.

**Hydraulic Excavator ZX17U-6,ZX19U-6,ZX26U-6**

**Operator's Manual (Original Instruction)**

Manual part number : ENMABK-EN1-2

Hitachi Construction Machinery (Europe) N.V.  
Address : Siciliëweg 5, 1045 AT, Amsterdam, The Netherlands  
URL : <http://www.hitachi-c-m.com>

