

PART NO. ENMDAT-MX1-8

HITACHI

Reliable solutions

# Operator's Manual

# ZAXIS

## 135US-6 class

135US-6

## 225US-6 class

225USLC-6

## 345US-6 class

345USLC-6

# Hydraulic Excavator

ZX135US-6 • 225USLC-6 • 345USLC-6 class HYDRAULIC EXCAVATOR OPERATOR'S MANUAL

 Hitachi Construction Machinery Co., Ltd.

URL:<http://www.hitachi-c-m.com>

PRINTED IN JAPAN (K) 2022, 03

ENMDAT-MX1-8

Serial No.

ZX135US-6 class

100001 and up

ZX225US-6 class

500001 and up

ZX345US-6 class

500001 and up

## INTRODUCTION

**Read this manual** carefully to learn how to operate and service your machine correctly. Failure to do so could result in personal injury or machine damage.

**This standard specification machine** can be operated under the following conditions without being modified.  
Atmospheric Temperature: -20 °C to 40 °C (-4 °F to 104 °F)  
Altitude: 0 m to 2000 m (0 ft to 6600 ft)

In case the machine is used under conditions other than described above, consult your authorized dealer.

**This manual should be considered** a permanent part of your machine and should remain with the machine when you sell it.

**This machine is of metric** design. Measurements in this manual are metric. Use only metric hardware and tools as specified.

**Right-hand and left-hand** sides are determined by facing in the direction of forward travel.

**Write product identification numbers** in the Machine Numbers section. Accurately record all the numbers to help in tracing the machine should it be stolen. Your dealer also needs these numbers when you order parts. If this manual is kept on the machine, also file the identification numbers in a secure place off the machine.

Be sure to use fuel that complies with JIS K-2204, EN-590 or ASTM D-975 which contains 15 ppm or lower sulfur. Also use fuel that complies with solid contamination level of class 18/16/13 of ISO4406-1999 (solid contamination includes dust). If the fuel specified above is not used, exhaust gas that exceeds the regulation values may be discharged, causing serious problem on the engine. Consult your authorized dealer.

A standard specification machine is not intended to be used in applications such as demolition for which additional safety measures are necessary (e.g. protective guards, glazing). Consult your authorized dealer for information on available parts.

**Warranty** is provided as a part of Hitachi's support program for customers who operate and maintain their equipment as described in this manual. The warranty is explained on the warranty certificate which you should have received from your dealer.

This warranty provides you the assurance that Hitachi will back its products where defects appear within the warranty period. In some circumstances, Hitachi also provides field improvements, often without charge to the customer, even if the product is out of warranty.

**Should the equipment be abused, or modified to change its performance beyond the original factory specifications, the warranty will become void and field improvements may be denied.**

Setting fuel delivery above specifications or otherwise overpowering machines will result in such action.

Only qualified, experienced operators officially licensed (according to local law) should be allowed to operate the machine. Moreover, only officially licensed personnel should be allowed to inspect and service the machine.

**PRIOR TO OPERATING THIS MACHINE, INCLUDING COMMUNICATION SYSTEM, IN A COUNTRY OTHER THAN A COUNTRY OF ITS INTENDED USE, IT MAY BE NECESSARY TO MAKE MODIFICATIONS TO IT SO THAT IT COMPLIES WITH THE LOCAL REGULATORY STANDARDS (INCLUDING SAFETY STANDARDS) AND LEGAL REQUIREMENTS OF THAT PARTICULAR COUNTRY. PLEASE DO NOT EXPORT OR OPERATE THIS MACHINE OUTSIDE OF THE COUNTRY OF ITS INTENDED USE UNTIL SUCH COMPLIANCE HAS BEEN CONFIRMED. PLEASE CONTACT HITACHI CONSTRUCTION MACHINERY CO., LTD. OR ANY OF OUR AUTHORIZED DISTRIBUTOR OR DEALER IF YOU HAVE ANY QUESTIONS CONCERNING COMPLIANCE.**

**In this manual, urea water is indicated as DEF/ AdBlue®.**

**"DEF" stands for the Diesel Exhaust Fluid.**

**AdBlue® is a registered trademark of the Verband der Automobilindustrie e.V. (VDA).**

Jubilee® is a registered trademark of the L Robinson & Co (Gillingham) Limited.

Hycolin® is a registered trademark of the USUI CO., LTD.

### CALIFORNIA Proposition 65 Warning

**Diesel engine exhaust and some of its constituents are known to the State of California to cause cancer, birth defects, and other reproductive harm.**

All information, illustrations and specifications in this manual are based on the latest product information available at the time of publication. The right is reserved to make changes at any time without notice.

# INDEX

MACHINE NUMBERS

SAFETY

VISIBILITY MAP

SAFETY SIGNS

NAME OF COMPONENTS

GETTING ON AND OFF THE MACHINE

OPERATOR'S STATION

BREAK-IN

OPERATING THE ENGINE

DRIVING THE MACHINE

OPERATING THE MACHINE

TRANSPORTING

MAINTENANCE

MAINTENANCE UNDER SPECIAL ENVIRONMENTAL CONDITIONS

STORAGE

TROUBLESHOOTING

SPECIFICATIONS

OPTIONAL ATTACHMENTS AND DEVICES

INDEX



# CONTENTS

<b>MACHINE NUMBERS .....</b>	<b>1</b>	Avoid Applying Heat to Lines Containing Flammable Fluids.....	S-35
<b>SAFETY .....</b>	<b>S-1</b>	Precautions for Handling Accumulator and Gas Damper .....	S-35
Recognize Safety Information .....	S-1	Remove Paint Before Welding or Heating .....	S-36
Understand Signal Words.....	S-1	Beware of Asbestos and Silica Dust and Other Contamination.....	S-36
Follow Safety Instructions.....	S-2	Prevent Battery Explosions .....	S-37
Prepare for Emergencies.....	S-3	Service Air Conditioning System Safely .....	S-37
Wear Protective Clothing.....	S-3	Handle Chemical Products Safely.....	S-38
Protect Against Noise .....	S-4	Dispose of Waste Properly.....	S-38
Inspect Machine .....	S-4	Never Ride Attachment.....	S-39
General Precautions for the Cab.....	S-5	Notes on Aftertreatment Device .....	S-39
Use Handholds and Steps .....	S-6	Precautions for Communication Terminal.....	S-39
Adjust the Operator's Seat.....	S-6	Precautions for Communication Terminal Equipment ...	S-40
Ensure Safety Before Rising from or Leaving Operator's Seat .....	S-7	Notes on Protection of Operator's Station when the Machine Rolls Over.....	S-42
Fasten Your Seat Belt.....	S-7	<b>VISIBILITY MAP .....</b>	<b>S-43</b>
Move and Operate Machine Safely.....	S-8	<b>SAFETY SIGNS .....</b>	<b>S-49</b>
Operate Only from Operator's Seat .....	S-8	<b>NAME OF COMPONENTS .....</b>	<b>1-1</b>
Jump Starting .....	S-9	<b>GETTING ON AND OFF THE MACHINE .....</b>	<b>1-2</b>
Keep Riders off Machine .....	S-9	<b>OPERATOR'S STATION.....</b>	<b>1-3</b>
Precautions for Operations .....	S-10	About Aftertreatment Device .....	1-3
Investigate Job Site Beforehand .....	S-11	Cab Features.....	1-6
Install OPG Guard .....	S-12	Cab Features.....	1-7
Restriction of Attachment Installation .....	S-12	Multi Function Monitor .....	1-8
Provide Signals for Jobs Involving Multiple Machines....	S-13	Default Setting .....	1-9
Confirm Direction of Machine to Be Driven.....	S-13	Basic Screen.....	1-10
Drive Machine Safely.....	S-14	How to Use Screens.....	1-11
Avoid Injury from Rollaway Accidents.....	S-16	Displaying Basic Screen .....	1-11
Avoid Injury from Back-Over and Swing Accidents .....	S-17	Hour Meter .....	1-14
Keep People Clear from Working Area .....	S-18	Clock.....	1-14
Never Position the Bucket Over Anyone.....	S-18	Fuel Gauge .....	1-14
Avoid Undercutting.....	S-19	DEF/AdBlue® Gauge.....	1-15
Avoid Tipping.....	S-19	DEF/AdBlue® Level Alarm .....	1-15
Never Undercut a High Bank.....	S-20	Coolant Temperature Gauge .....	1-16
Dig with Caution.....	S-20	Operating Status Icon Display.....	1-16
Operate with Caution .....	S-20	Security Functions (Optional) .....	1-17
Avoid Power Lines.....	S-21	Input Password .....	1-17
Precautions for Lightning.....	S-21	Extending Password Duration Time .....	1-18
Object Handling .....	S-22	Alarm Occurrence Screen.....	1-19
Protect Against Flying Debris and Falling Object.....	S-23	Remedy .....	1-21
Park Machine Safely.....	S-24	Urea SCR System Remedy .....	1-24
Handle Fluids Safely—Avoid Fires.....	S-24	Aftertreatment Device.....	1-26
Transport Safely .....	S-25	Aftertreatment Device Condition Display .....	1-26
Practice Safe Maintenance.....	S-26	Aftertreatment Device Manual Regeneration Request .....	1-27
Warn Others of Service Work .....	S-27	Manual Regeneration Procedure .....	1-28
Support Machine Properly.....	S-27	Main Menu.....	1-29
Stay Clear of Moving Parts .....	S-28	Engine Output Restriction Suspend.....	1-30
Prevent Parts from Flying .....	S-28	Urea SCR System Troubleshooting.....	1-32
Avoid Injury from Attachment Falling Accident .....	S-29	Air Conditioner.....	1-34
Prevent Burns.....	S-29	Circulation Air Mode.....	1-34
Replace Rubber Hoses Periodically.....	S-30		
Avoid High-Pressure Fluids .....	S-30		
Prevent Fires.....	S-31		
Evacuating in Case of Fire.....	S-33		
Beware of Exhaust Fumes.....	S-33		
Precautions for Welding and Grinding .....	S-34		
Avoid Heating Near Pressurized Fluid Lines .....	S-35		

## CONTENTS

Air Conditioner ON/OFF .....	1-34	Travel Alarm Deactivation Switch (Optional).....	1-101
Radio .....	1-35	Rear Light Switch .....	1-101
Work Mode .....	1-36	Perimeter Lights Switch (Optional) .....	1-101
Attachment Selection .....	1-36	Seat Heater Switch (Optional) .....	1-102
Mail (Optional).....	1-37	Electrical Control Main Switch .....	1-103
Setting Menu .....	1-39	Key Switch.....	1-104
Date and Time.....	1-40	Power Boost Switch .....	1-104
Time Adjustment .....	1-40	Horn Switch.....	1-104
Date Adjustment.....	1-42	Electrical Control Main Switch.....	1-105
Display Mode Setting.....	1-44	AUX Function Lever 1 .....	1-106
Attachment Adjustment.....	1-46	Cigar Lighter.....	1-107
Flow Rate Adjustment.....	1-46	Using Cigar Lighter.....	1-107
Priority (arm roll-out).....	1-48	Cab Light Switch.....	1-108
Priority (arm roll-in) (Except ZX135US-6) .....	1-50	Pilot Control Shut-Off Lever .....	1-109
Attachment Name Input.....	1-52	Control Lever Auto-Lock.....	1-110
Auto Shut-Down.....	1-54	Engine Stop Switch.....	1-111
Auto Shut-Down: ON/OFF .....	1-54	Fuse Box.....	1-112
Auto Shut-Down: Setting Time .....	1-55	Auto Air Conditioner .....	1-113
Aftertreatment Device Regeneration Inhibited .....	1-56	Features:.....	1-113
Setting Procedure .....	1-56	Name of Components.....	1-114
Password Change (Optional).....	1-58	Controller Part Name and Function .....	1-115
Sub Meter .....	1-62	Cab Heater Operation .....	1-117
Brightness Adjustment.....	1-64	Cooling Operation.....	1-118
Language Settings.....	1-66	Defroster Operation.....	1-119
Lists of Display Language.....	1-68	Cool Head/Warm Feet Operation.....	1-119
Unit Selection .....	1-69	Tips for Optimal Air Conditioner Usage .....	1-120
Display Item Selection (Rear View Camera OFF) .....	1-71	For Rapid Cooling .....	1-120
Main Menu Sequence Change .....	1-73	When Windows Become Misty.....	1-120
Information Menu .....	1-75	Off-Season Air Conditioner Maintenance .....	1-120
Operation .....	1-76	AM/FM Radio Operation .....	1-121
Fuel Consumption .....	1-76	Controls on the Radio.....	1-121
Breaker Operation .....	1-78	Tuning Procedure .....	1-121
Attachment Operation.....	1-80	Station Presetting Procedure.....	1-122
Travel Operation.....	1-82	Station Auto-Presetting Procedure .....	1-123
Actual operation .....	1-84	TONE Control.....	1-124
Maintenance .....	1-82	Audio Input.....	1-125
Remaining Time and Maintenance Interval .....	1-88	Aerial Angle Monitor .....	1-126
Monitoring.....	1-90	Switching the Screen Display .....	1-128
Switch Panel.....	1-92	Description of Images.....	1-129
Return to Previous Screen Switch (Monitor) .....	1-93	Cab Door Release Lever .....	1-133
Return to Basic Screen Switch (Monitor) .....	1-93	Opening/Closing and Removing Cab Inside Window ..	1-134
Selector Knob (Monitor).....	1-93	Opening Upper Front Window .....	1-135
Temperature Control Switch/Mode Switch		Removing and Storing Lower Front Window .....	1-136
(Air Conditioner) .....	1-93	Opening Side Window.....	1-137
AUTO/OFF Switch/Fan Switch (Air Conditioner).....	1-93	Opening and Closing the Roll Screen	
AM/FM Selector/Tuning Switch (Radio).....	1-95	(for Front and Right Windows) (Optional).....	1-138
Power Switch/Volume Control Knob (Radio).....	1-95	How to Use on the Front Window.....	1-138
Engine Control Dial .....	1-95	How to Store on Right Window Side.....	1-140
Auto-Idle Switch.....	1-95	How to Use on Right Window Side.....	1-140
Travel Mode Switch .....	1-95	How to clean the screen.....	1-140
Power Mode Switch .....	1-96	Opening/Closing Overhead Window (Clear Hatch).....	1-141
Work Light Switch.....	1-96	Emergency Exit .....	1-142
Wiper/Washer Switch .....	1-97	Opening and Closing the OPG Front Guard	
USB Power Supply Port.....	1-98	(Optional).....	1-143
Numeric Keypad.....	1-99	Adjusting Operator's Seat .....	1-144
Switch Panel (for Optional Equipments).....	1-100	Seat Height and Angle Adjustment .....	1-144

# CONTENTS

Console and Seat Fore-aft Adjustment.....	1-144	Auto-Idle ON/OFF .....	5-6
Seat Fore-Aft Adjustment .....	1-144	Auto Shut-Down.....	5-7
Suspension Adjustment .....	1-144	Aftertreatment Device Manual Regeneration .....	5-10
Backrest Adjustment .....	1-145	Work Mode .....	5-12
Armrest Adjustment .....	1-145	Power Boost Switch .....	5-15
Adjusting Operator's Seat (Optional) .....	1-146	Power Mode .....	5-16
Adjusting Seat Height .....	1-146	Operating Backhoe.....	5-17
Console and Seat Fore-aft Adjustment.....	1-146	Shovel.....	5-18
Seat Fore-Aft Adjustment .....	1-146	Grading Operation.....	5-19
Suspension Adjustment .....	1-147	Do Not Strike the Ground with Bucket Teeth .....	5-20
Fore-Aft Position Adjustment of Seat Surface.....	1-147	Avoid Hammer Work .....	5-20
Angle Adjustment of Seat Surface.....	1-147	Avoid Abusive Operation .....	5-21
Backrest Adjustment .....	1-147	Never Move an Object Sideways with the Bucket.....	5-21
Armrest Adjustment .....	1-147	Retracting the Arm and Bucket.....	5-22
Console Height Adjustment .....	1-148	Do Not Use Wide Track Shoes on Rough Ground .....	5-22
Adjusting Procedures.....	1-148	Shackle Hole Usage .....	5-23
Installation and Adjustment of Mirrors .....	1-149	Pilot Accumulator Functions (Optional).....	5-24
Mirror Installation Diagram .....	1-150	How to Lower Boom in Case of Emergency and When Engine Stops.....	5-25
Seat Belt.....	1-157	Precautions for After Operations .....	5-26
Battery Disconnect Switch.....	1-158	<b>TRANSPORTING .....</b>	<b>6-1</b>
Switch Operation .....	1-160	Transporting by Road .....	6-1
<b>BREAK-IN .....</b>	<b>2-1</b>	Loading/Unloading on a Trailer .....	6-2
Observe Engine Operation Closely.....	2-1	Fastening Machine for Transporting .....	6-5
Every 8 Hours or Daily.....	2-1	Unloading .....	6-6
After the First 50 Hours .....	2-1	Lifting Machine .....	6-7
After the First 100 Hours.....	2-1	<b>MAINTENANCE.....</b>	<b>7-1</b>
<b>OPERATING THE ENGINE .....</b>	<b>3-1</b>	Correct Maintenance and Inspection Procedures.....	7-1
Inspect Machine Daily Before Starting .....	3-1	Layout.....	7-3
Before Starting Engine .....	3-3	Layout.....	7-4
Starting the Engine.....	3-4	Check the Hour Meter Regularly.....	7-5
Check Instruments After Starting.....	3-10	Maintenance Guide Table .....	7-6
Using Booster Batteries.....	3-11	Preparations for Inspection and Maintenance .....	7-10
Stopping the Engine .....	3-13	Hood and Access Covers.....	7-11
Engine Auto-Stop in Extremely Low Temperature.....	3-14	Maintenance Guide .....	7-14
<b>DRIVING THE MACHINE .....</b>	<b>4-1</b>	Periodic Replacement of Parts.....	7-20
Travel Levers and Pedals.....	4-1	Kind of Oils.....	7-21
Travel Mode Switch .....	4-3	Brand Names of Recommended Grease.....	7-21
Travel Alarm (Optional) .....	4-3	Recommended Engine Oil.....	7-21
Operating on Soft Ground .....	4-4	Brand Names of Recommended Oil.....	7-22
Raising the Machine with Boom and Arm.....	4-4	Brand Names of Recommended Hydraulic Oil.....	7-22
Retrieval .....	4-5	Recommended Oil Viscosity .....	7-23
Operating in Water or Mud .....	4-6	List of Consumable Parts .....	7-24
Parking the Machine on Slopes.....	4-7	A. Greasing.....	7-30
Parking the Machine .....	4-7	Front Joint Pins .....	7-30
Prohibition of Sudden Control Operations when Traveling at High Speed .....	4-8	Swing Bearing .....	7-32
Prohibition of Traveling for Long Periods.....	4-8	Swing Internal Gear.....	7-33
<b>OPERATING THE MACHINE .....</b>	<b>5-1</b>	Electric Grease Gun (Nickel-Cadmium Battery) (Only ZX345US-6 class) .....	7-35
Control Lever (ISO Pattern) .....	5-1	Electric Grease Gun.....	7-37
Pilot Control Shut-Off Lever .....	5-2	Components Name .....	7-38
Warming-Up Operation .....	5-3	Battery Charger Operation .....	7-39
Engine Speed Control.....	5-4	Charger Lamps.....	7-39
Auto-Idle.....	5-5	Electric Grease Gun (Lithium-ion Battery)	
Auto-Idle Function .....	5-5		



## CONTENTS

(Only ZX345US-6 class).....	7-44	Convert Bucket Connection Into Face Shovel .....	7-116
Electric Grease Gun.....	7-46	Adjust Bucket Linkage .....	7-117
Components Name .....	7-47	Remove Travel Levers .....	7-118
Battery Charger Operation .....	7-48	Check and Replace Seat Belt.....	7-118
Charger Lamps.....	7-48	Check Windshield Washer Fluid Level .....	7-119
B. Engine .....	7-53	Check Track Sag .....	7-120
Check Engine Oil Level.....	7-53	Clean and Replace Air Conditioner Filter .....	7-125
Change Engine Oil .....	7-55	Check Air Conditioner .....	7-128
Replace Engine Oil Filter.....	7-55	Clean Cab Floor.....	7-130
Sampling the Engine Oil (Only ZX225USLC-6).....	7-58	Retighten Cylinder Head Bolt.....	7-131
Check and Clean Around the Engine.....	7-59	Inspect and Adjust Valve Clearance .....	7-131
Replace Oil Separator Element (Only ZX135US-6).....	7-59	Measure Engine Compression Pressure.....	7-131
C. Transmission .....	7-60	Check Starter and Alternator .....	7-131
Pump Transmission (Except ZX135US-6).....	7-60	Check and Replace EGR Device .....	7-131
Swing Reduction Gear .....	7-61	EGR Cooler Cleaning.....	7-131
Travel Reduction Gear .....	7-62	Check Turbo Charger.....	7-131
D. Hydraulic System.....	7-64	Check and Clean Injector .....	7-132
Inspection and Maintenance of Hydraulic Equipment... 7-64		Check Gas Damper .....	7-132
Check Hydraulic Oil Level .....	7-67	Tightening and Retightening Torque of	
Change Hydraulic Oil.....	7-68	Nuts and Bolts.....	7-132
Sampling the Engine Oil.....	7-69	J. Aftertreatment Device .....	7-161
Bleed Air from the Hydraulic System .....	7-70	Check and Clean Aftertreatment Device.....	7-161
Suction Filter Cleaning.....	7-71	K. Urea SCR System .....	7-162
Replace Full-Flow Filter.....	7-72	Check DEF/AdBlue® .....	7-164
Replace Pilot Oil Filter.....	7-73	Refill DEF/AdBlue® .....	7-164
Replace Air Breather Element.....	7-74	Clean Filler Port Strainer.....	7-167
Check Hoses and Lines .....	7-75	Change DEF/AdBlue® .....	7-168
E. Fuel System .....	7-79	Replace DEF/AdBlue® Supply Module Main Filter ....	7-169
Recommended Fuel.....	7-79	Replace DEF/AdBlue® Tank Water Supply	
Drain Fuel Tank Sump.....	7-81	Inlet Filter .....	7-171
Drain Fuel Pre-Filter.....	7-82	Replace the DEF/AdBlue® back flow line filter .....	7-172
Replace Fuel Main Filter Element .....	7-85	L. Aerial Angle .....	7-173
Replace Fuel Pre-Filter Element .....	7-87	Daily Checks of Aerial Angle Camera Images .....	7-173
Check Fuel Hoses .....	7-89	Checking Aerial Angle Camera Images.....	7-174
F. Air Cleaner.....	7-90		
Clean and Replace Air Cleaner Element (Outer) .....	7-90	<b>MAINTENANCE UNDER SPECIAL ENVIRONMENTAL</b>	
Replace Air Cleaner Element (Inner) .....	7-92	<b>CONDITIONS .....</b>	<b>9-1</b>
G. Cooling System .....	7-93	<b>STORAGE .....</b>	<b>10-1</b>
Check Coolant Level .....	7-94	Storing the Machine.....	10-1
Check and Adjust Fan Belt Tension.....	7-96		
Change Coolant.....	7-98	<b>TROUBLESHOOTING.....</b>	<b>11-1</b>
Clean Radiator/Oil Cooler/Inter Cooler Core.....	7-100		
Clean Oil Cooler, Radiator and Inter Cooler		<b>SPECIFICATIONS .....</b>	<b>12-1</b>
Front Screen .....	7-102	Specifications.....	12-1
Clean Air Conditioner Condenser .....	7-102	ZX135US-6.....	12-1
Clean Fuel Oil Cooler .....	7-102	Working Ranges (Grouser shoe).....	12-2
Drain Intercooler (only ZX135US-6) .....	7-103	ZX135US-6.....	12-2
H. Electrical System.....	7-104	Shoe Types and Applications .....	12-3
Battery.....	7-105	ZX135US-6.....	12-3
Replace Battery.....	7-108	Bucket Types and Applications .....	12-4
Check Electrolyte Specific Gravity .....	7-109	ZX135US-6.....	12-4
Replacing Fuses .....	7-110	Specifications.....	12-5
Fuse Box.....	7-111	ZX225USLC-6.....	12-5
I. Miscellaneous.....	7-113	Working Ranges (Grouser shoe).....	12-6
Check and Replace Bucket Teeth .....	7-113	ZX225USLC-6.....	12-6
Change Bucket.....	7-115	Shoe Types and Applications .....	12-7
		ZX225USLC-6.....	12-7



# CONTENTS

---

Bucket Types and Applications .....	12-8
ZX225USLC-6.....	12-8
Specifications.....	12-9
ZX345USLC-6.....	12-9
Working Ranges.....	12-10
ZX345USLC-6.....	12-10
Shoe Types and Applications .....	12-11
ZX345USLC-6.....	12-11
Bucket Types and Applications .....	12-12
ZX345USLC-6.....	12-12
<b>OPTIONAL ATTACHMENTS AND DEVICES.....</b>	<b>13-1</b>
Using Pad Crawler Shoe .....	13-1
Traveling and Other Cautions.....	13-2
Transporting.....	13-3
Precautions for Transporting Machines with	
Pad Crawler Shoes .....	13-3
Long Arm Operation .....	13-8
Blade Lever .....	13-9
Avoid Hitting Blade with Front-End Attachment.....	13-10
Blade Maintenance .....	13-11
Specifications.....	13-12
ZX135US-6 with Blade .....	13-12
Working Ranges.....	13-13
ZX135US-6 with Blade .....	13-13
Shoe Types and Applications .....	13-14
ZX135US-6 with Blade .....	13-14
Specifications.....	13-15
ZX225USLC-6 with Blade.....	13-15
Working Ranges (Grouser shoe).....	13-16
ZX225USLC-6 with Blade.....	13-16
Shoe Types and Applications .....	13-17
ZX225USLC-6 with Blade.....	13-17
Bucket Teeth (Transverse-Type-Pin-Used Type) .....	13-18
Control Lever (4 Way Multi Valve) (Optional).....	13-19
Hydraulic Breaker, Hydraulic Crusher and	
Quick Coupler.....	13-20
Piping for Breaker and Crusher .....	13-21
Operational Procedures for Stop Valves and	
Selector Valve .....	13-21
Secondary Relief Pressure Adjustment .....	13-22
Precautions for Breaker Operation.....	13-23
Change Hydraulic Oil and Replace Full-Flow	
Filter Element .....	13-27
Precautions for Crusher Operation .....	13-28
Attachment.....	13-31
Allowable Weight Limits of Installed Attachment ....	13-31
Attachment Connection Parts .....	13-33
Precautions for Arm Roll-In/Bucket Roll-In	
Combined Operation .....	13-35
<b>INDEX.....</b>	<b>14-1</b>

---



# MACHINE NUMBERS

The manufacturing Nos. explained in this group is the individual number (serial No.) given to each machine and main components. These numbers are requested when inquiring any information on the machine and/or components. Fill these serial Nos. in the blank spaces in this group to immediately make them available upon request.

## Machine

TYPE : \_\_\_\_\_  
 PRODUCT IDENTIFICATION NUMBER : \_\_\_\_\_

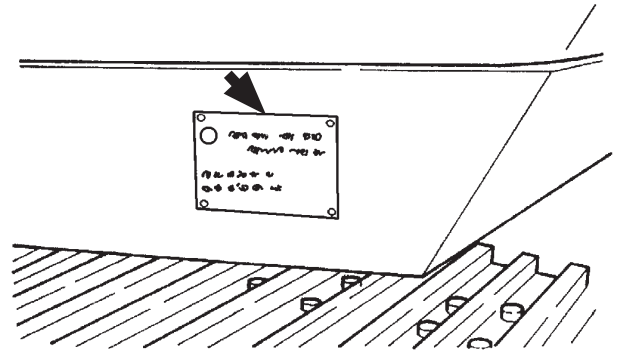

M157-00-001

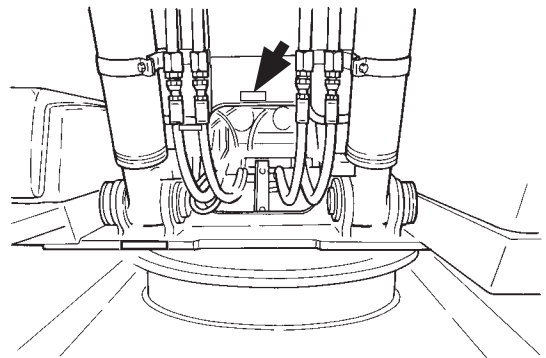

M157-12-008

## Product Identification Number

NOTE:

\*HCMDATA0000100001\*  
 Marks to indicate the start and end of the PIN  
 PRODUCT IDENTIFICATION NUMBER (PIN)

## Engine

TYPE : \_\_\_\_\_

MFG. NO. : \_\_\_\_\_

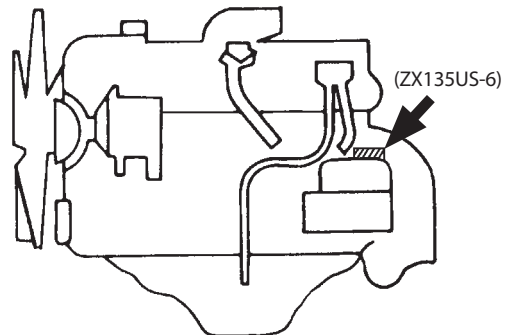

M178-00-002

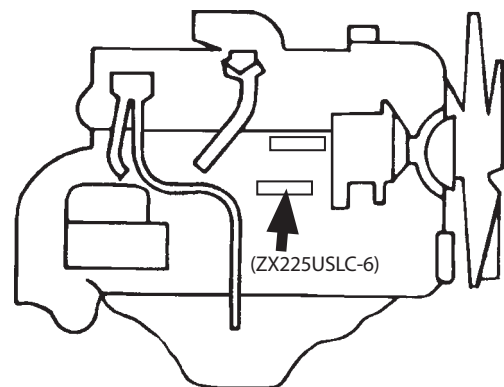

MDAA-00-001

## MACHINE NUMBERS

---

### SCR (Selective Catalytic Reduction) Catalyst

TYPE : \_\_\_\_\_

MFG. NO. : \_\_\_\_\_

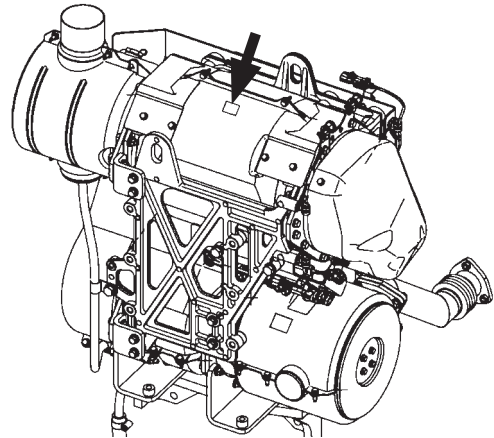

ZX135US-6

MDC1-00-002

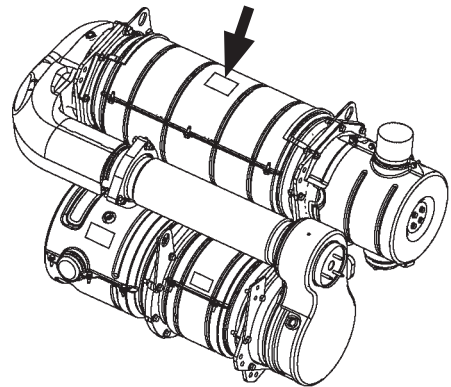

ZX225USLC-6

MDC1-00-001

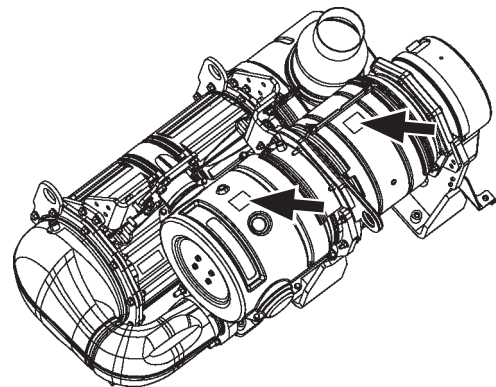

ZX345USLC-6

MDC1-01-510

# MACHINE NUMBERS

## DOC (Diesel Oxidation Catalyst)

TYPE : \_\_\_\_\_

MFG. NO. : \_\_\_\_\_

TYPE : \_\_\_\_\_

MFG. NO. : \_\_\_\_\_

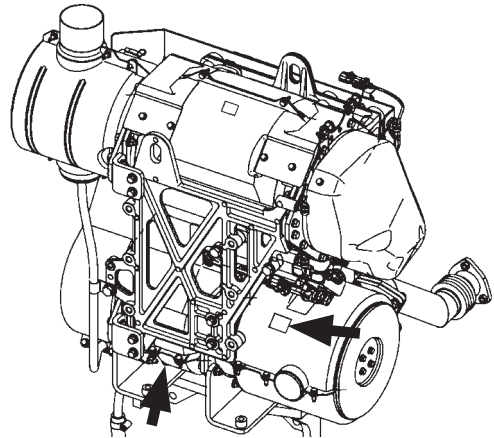

ZX135US-6

MDC1-00-002

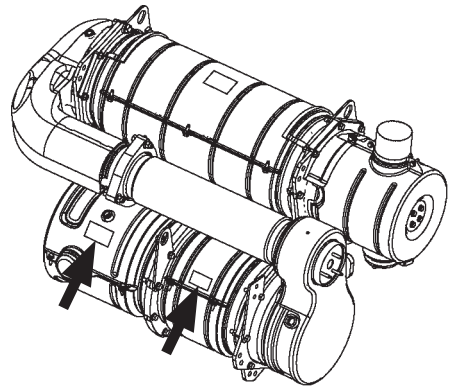

ZX225USLC-6

MDC1-00-001

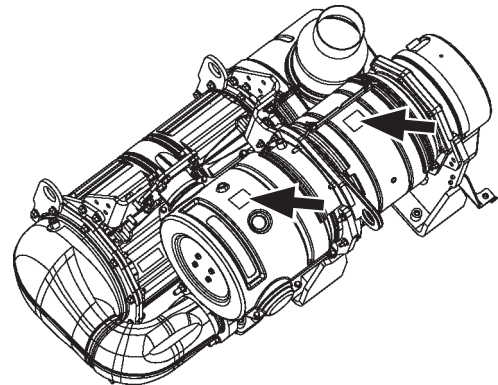

ZX345USLC-6

MDC1-01-510

# MACHINE NUMBERS

## Travel Motor

TYPE : \_\_\_\_\_

MFG. NO. : (L) \_\_\_\_\_

MFG. NO. : (R) \_\_\_\_\_

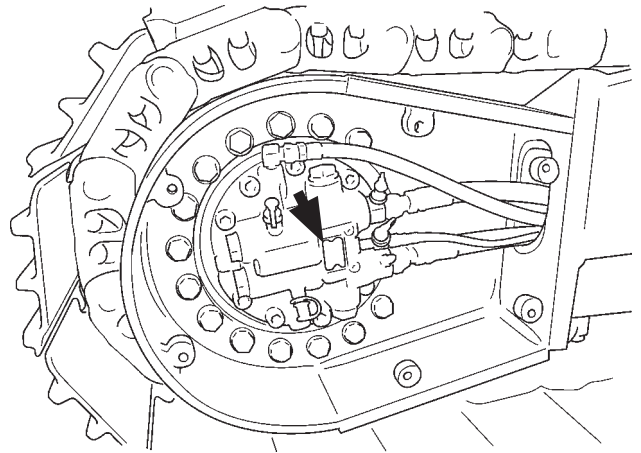

M178-07-047

## Swing Motor

TYPE : \_\_\_\_\_

MFG. NO. : \_\_\_\_\_

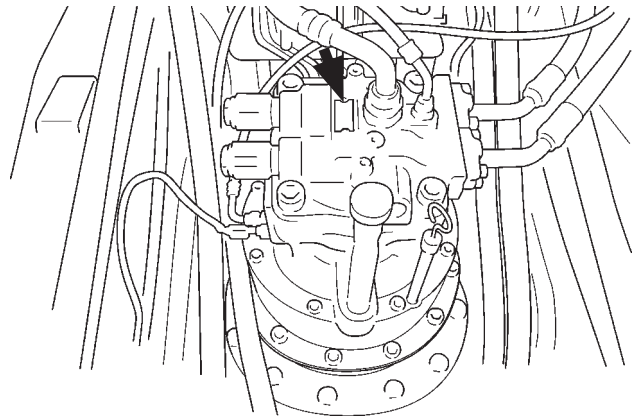

M178-07-086

# MACHINE NUMBERS

## Hydraulic Pump

TYPE : \_\_\_\_\_

MFG. NO. : \_\_\_\_\_

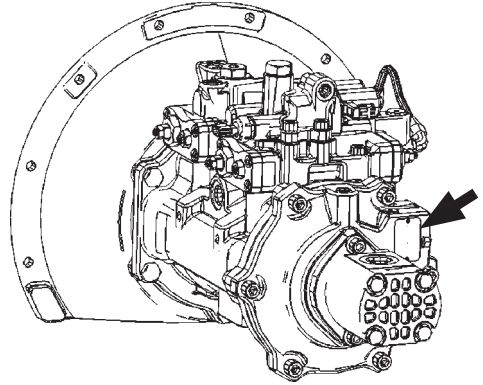

ZX135US-6

MDAA-07-072

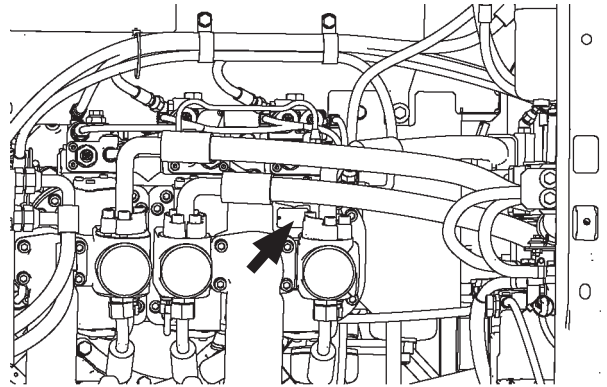

ZX225USLC-6

MDAA-00-003

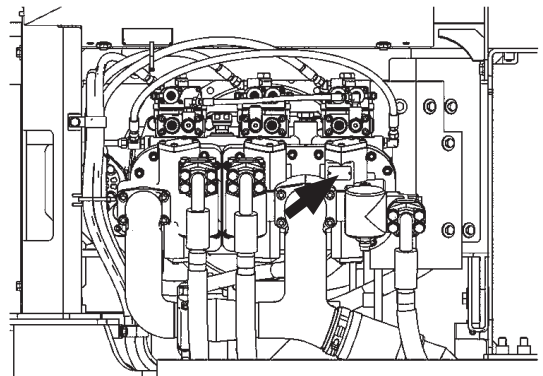

ZX345USLC-6

MDD5-00-002





## SAFETY

### Recognize Safety Information

- These are the SAFETY ALERT SYMBOLS.
  - When you see these symbols on your machine or in this manual, be alert to the potential for personal injury.
  - Follow recommended precautions and safe operating practices.



SA-2644

### Understand Signal Words

- On machine safety signs, signal words designating the degree or level of hazard - DANGER, WARNING, or CAUTION - are used with the safety alert symbol.
  - **DANGER** indicates an imminently hazardous situation which, if not avoided, will result in death or serious injury.
  - **WARNING** indicates a potentially hazardous situation which, if not avoided, could result in death or serious injury.
  - **CAUTION** indicates a potentially hazardous situation which, if not avoided, may result in minor or moderate injury.
  - **DANGER or WARNING safety signs** are located near specific hazards. General precautions are listed on **CAUTION safety signs**.
  - Some safety signs are occasionally used on this machine that do not use any of the designated signal words mentioned above after the safety alert symbol.



**IMPORTANT**



- To avoid confusing machine protection with personal safety messages, a signal word IMPORTANT indicates a situation which, if not avoided, could result in damage to the machine.
-  NOTE: Indicates an additional explanation for a piece of information.

SA-1223

## SAFETY

---

### Follow Safety Instructions

- Carefully read and follow all safety signs on the machine and all safety messages in this manual.
- Safety signs should be installed, maintained and replaced when necessary.
  - If a safety sign or this manual is damaged or missing, order a replacement from your authorized dealer in the same way you order other replacement parts (be sure to state machine model and serial number when ordering).
- Learn how to operate the machine and its controls correctly and safely.
- Allow only trained, qualified, authorized personnel to operate the machine.
- Keep your machine in proper working condition.
  - Unauthorized modifications of the machine may impair its function and/or safety and affect machine life.
  - Do not modify any machine parts without authorization. Failure to do so may deteriorate the safety, function, and/or service life of the part. In addition, personal accident, machine trouble, and/or damage to material caused by unauthorized modifications will void Hitachi Warranty Policy.
  - Never attempt to modify or disassemble the inlet/exhaust parts and the aftertreatment device. Avoid shocks to the element of the aftertreatment device, such as striking or dropping objects onto the element. Failure to do so may affect the exhaust gas purifying device, possibly damaging it or lowering its performance.
  - Do not use attachments and/or optional parts or equipment not authorized by Hitachi. Failure to do so may deteriorate the safety, function, and/or service life of the machine. In addition, personal accident, machine trouble, and/or damage to material caused by using unauthorized attachments and/or optional parts or equipment will void Hitachi Warranty Policy.
- The safety messages in this SAFETY chapter are intended to illustrate basic safety procedures of machines. However it is impossible for these safety messages to cover every hazardous situation you may encounter. If you have any questions, you should first consult your supervisor and/or your authorized dealer before operating or performing maintenance work on the machine.

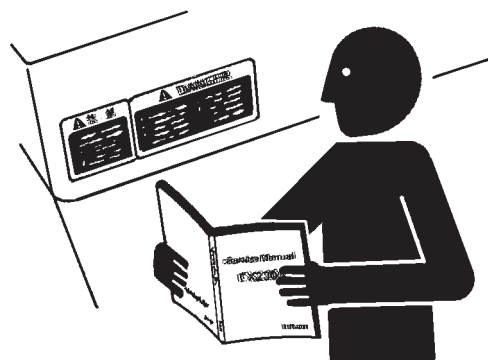

SA-003

## SAFETY

---

### Prepare for Emergencies

- Be prepared for a fire or an accident.
  - Keep a first aid kit and fire extinguisher on hand.
  - Thoroughly read and understand the label attached on the fire extinguisher to use it properly.
  - To ensure that a fire extinguisher can be always used when necessary, check and service the fire extinguisher at the recommended intervals as specified in the fire extinguisher manual.
  - Establish emergency procedure guidelines to cope with fires and accidents.
  - Keep emergency numbers for doctors, ambulance service, hospital, and fire department posted near your telephone.



SA-437

---

### Wear Protective Clothing

- Wear close fitting clothing and safety equipment appropriate to the job.

You may need:

- A hard hat
- Safety shoes
- Safety glasses, goggles, or face shield
- Heavy gloves
- Hearing protection
- Reflective clothing
- Wet weather gear
- Respirator or filter mask

Be sure to wear the correct equipment and clothing for the job. Do not take any chances.

- Avoid wearing loose clothing, jewelry, or other items that can catch on control levers or other parts of the machine.
- Operating equipment safely requires the full attention of the operator. Do not wear radio or music headphones while operating the machine.

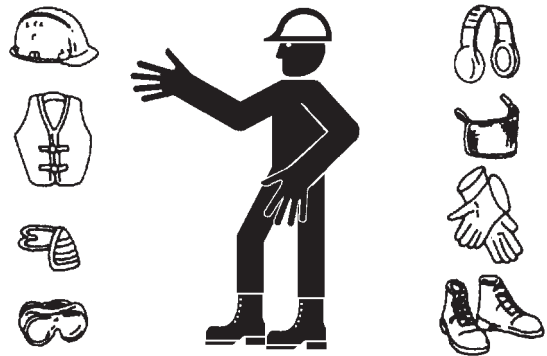

SA-438

## SAFETY

---

### Protect Against Noise

- Prolonged exposure to loud noise can cause impairment or loss of hearing.
  - Wear a suitable hearing protective device such as earmuffs or earplugs to protect against objectionable or uncomfortably loud noises.



SA-434

---

### Inspect Machine

- Inspect your machine carefully each day or shift by walking around it before you start it to avoid personal injury.
  - In the walk-around inspection be sure to cover all points described in the "Inspect Machine Daily Before Starting" section in the operator's manual.



SA-435

## SAFETY

---

### General Precautions for the Cab

- Before entering the cab, thoroughly remove all dirt and/or oil such as mud, grease, soil or stones from the soles of your work boots. If any controls such as a pedal is operated while with dirt and/or oil on the soles of the operator's work boots, the operator's foot may slip off the pedal, possibly resulting in a personal accident.
- Do not mess up around the operator's seat with parts, tools, soil, stones, obstacles that may fold up or turn over, cans or lunch box. The levers or pedals become inoperable if obstacle jams in operation stroke of the travel levers/pedals, pilot control shut-off lever or control levers, which may result in serious injury or death.
- Avoid storing transparent bottles in the cab. Do not attach any transparent type window decorations on the windowpanes as they may focus sunlight, possibly starting a fire.
- Refrain from listening to the radio, or using music headphones or mobile telephones in the cab while operating the machine.
- Keep all flammable materials and/or explosives away from the machine.
- After using the ashtray, always cover it to extinguish the match and/or tobacco.
- Do not leave cigarette lighters in the cab. When the temperature in the cab increases, the lighter may explode.
- Correctly lay the floor mat specific to the machine. If another floor mat is used, it may be displaced and contact with the travel pedals during operation, resulting in serious injury or death.

## SAFETY

---

### Use Handholds and Steps

- Falling is one of the major causes of personal injury.
  - When you get on and off the machine, always face the machine and maintain a three-point contact with the steps and handrails.
  - Do not use any controls as hand-holds.
  - Never jump on or off the machine. Never mount or dismount a moving machine.
  - Before getting on or off the machine, check the condition of the steps and handrails for sticking or slippery material like grease or mud. Thoroughly remove such material if stuck. In addition, repair the damage to the steps and/or handrails. Retighten loose bolts.
  - Never get on and off the machine with tools in your hands.



SA-439

---

### Adjust the Operator's Seat

- A seat which is poorly adjusted for the individual operator, or the work to be undertaken, may quickly fatigue the operator leading to misoperation.
  - The seat should be adjusted whenever the operator of the machine changes.
  - The operator should be able to fully depress the pedals and to correctly operate the control levers with his back against the seat back.
  - If not, move the seat forward or backward, and check again.
  - Adjust the rear view mirror position so that the best rear visibility is obtained from the operator's seat. If the mirror is broken, immediately replace it with a new one.



SA-378



## SAFETY

---

### Ensure Safety Before Rising from or Leaving Operator's Seat

- Before rising from the operator's seat to open/close either side window or to adjust the seat position, be sure to first lower the front attachment to the ground and then move the pilot control shut-off lever to the LOCK position. Failure to do so may allow the machine to unexpectedly move when a body part unintentionally comes in contact with a control lever and/or pedal, possibly resulting in serious personal injury or death.
- Before leaving the machine, be sure to first lower the front attachment to the ground and then move the pilot control shut-off lever to the LOCK position. Turn the key switch OFF to stop the engine.
- Before leaving the machine, close all windows, doors, and access covers and lock them.

---

### Fasten Your Seat Belt

- If the machine should overturn, the operator may become injured and/or thrown from the cab. Additionally the operator may be crushed by the overturning machine, resulting in serious injury or death.
  - Prior to operating the machine, thoroughly examine webbing, buckle and attaching hardware. If any item is damaged or worn, replace the seat belt or component before operating the machine.
  - Be sure to remain seated with the seat belt securely fastened at all times when the machine is in operation to minimize the chance of injury from an accident.
  - We recommend that the seat belt is replaced every three years regardless of its apparent condition.



SA-237

## SAFETY

---

### Move and Operate Machine Safely

- Bystanders can be run over.
  - Take extra care not to run over bystanders. Confirm the location of bystanders before moving, swinging, or operating the machine.
  - Always keep the travel alarm and horn in working condition (if equipped). It warns people when the machine starts to move.
  - Use a signal person when moving, swinging, or operating the machine in congested areas. Coordinate hand signals before starting the machine.
  - Use appropriate illumination. Check that all lights are operable before operating the machine. If any faulty illumination is present, immediately repair it.
  - Ensure the cab door, windows, doors and covers are securely locked.
  - Check the mirrors and the monitor in the cab for problems.  
If there is, replace the problem part (s) or clean the mirror, camera lens and the monitor display.  
Refer to Mirror section and Rear View Monitor section for information on cleaning the mirrors, camera lens and monitor display.



SA-426

---

### Operate Only from Operator's Seat

- Inappropriate engine starting procedures may cause the machine to runaway, possibly resulting in serious injury or death.
  - Start the engine only when seated in the operator's seat.
  - Never start the engine while standing on the track or ground.
  - Do not start engine by shorting across starter terminals.
  - Before starting the engine, confirm that all control levers are in neutral.
  - Before starting the engine, confirm the safety around the machine and sound the horn to alert bystanders.



SA-444

## SAFETY

---

### Jump Starting

- Battery gas can explode, resulting in serious injury.
  - If the engine must be jump started, be sure to follow the instructions shown in the “OPERATING THE ENGINE” chapter in the operator’s manual.
  - The operator must be in the operator’s seat so that the machine will be under control when the engine starts. Jump starting is a two-person operation.
  - Never use a frozen battery.
  - Failure to follow correct jump starting procedures could result in a battery explosion or a runaway machine.



SA-032

---

### Keep Riders off Machine

- Riders on machine are subject to injury such as being struck by foreign objects and being thrown off the machine.
  - Only the operator should be on the machine. Keep riders off.
  - Riders also obstruct the operator’s view, resulting in the machine being operated in an unsafe manner.



SA-379

## SAFETY

---

### Precautions for Operations

- Investigate the work site before starting operations.
  - Be sure to wear close fitting clothing and safety equipment appropriate for the job, such as a hard hat, etc. when operating the machine.
  - Keep bystanders and obstacles clear of the area of machine operation.  
Keep persons other than the operator away from areas where there is danger, such as from flying objects. Always be aware of the surroundings while operating. When working in a small area surrounded by obstacles, take care not to hit the upperstructure against obstacles.
- When loading onto trucks, bring the bucket over the truck beds from the rear side. Take care not to swing the bucket over the cab or over any person.

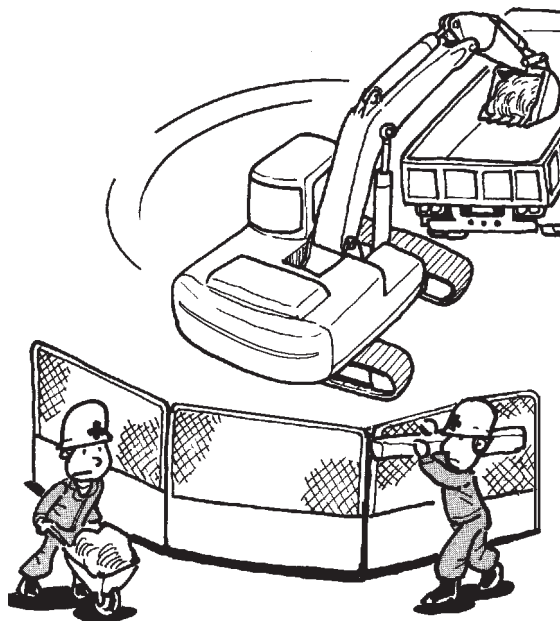

M178-05-007

## SAFETY

---

### Investigate Job Site Beforehand

- When working at the edge of an excavation or on a road shoulder, the machine could tip over, possibly resulting in serious injury or death.
  - Investigate the configuration and ground conditions of the job site beforehand to prevent the machine from falling and to prevent the ground, stockpiles or banks from collapsing.
  - Make a work plan. Use machines appropriate to the work and job site.
  - Reinforce ground, edges and road shoulders as necessary. Keep the machine well back from the edges of excavations and road shoulders.
  - When working on an incline or on a road shoulder, employ a signal person as required.
  - Confirm that your machine is equipped with a FOPS cab before working in areas where the possibility of falling stones or debris exist.
  - When the ground footing is weak, reinforce the ground before starting work.
  - When working on frozen ground, be extremely alert. As ambient temperatures rise, footing becomes loose and slippery.
  - Beware the possibility of fire when operating the machine near flammable materials such as dry grass.



SA-380

## SAFETY

- Make sure the worksite has sufficient strength to firmly support the machine.  
When working close to an excavation or at road shoulders, operate the machine with the tracks positioned perpendicular to the cliff face with travel motors at the rear, so that the machine can more easily evacuate if the cliff face collapses.
- If working on the bottom of a cliff or a high bank is required, be sure to investigate the area first and confirm that no danger of the cliff or bank collapsing exists. If any possibility of cliff or bank collapsing exists, do not work on the area.
- Soft ground may collapse when the machine is operated on it, possibly causing the machine to tip over. When working on soft ground is required, be sure to reinforce the ground first using steel plates strong and firm enough to easily support the machine.
- Note that there is always a possibility of machine tipping over when working on rough terrain or on slopes. Prevent machine tipping over from occurring. When operating on rough terrain or on slopes:
  - Reduce the engine speed.
  - Select slow travel speed mode.
  - Operate the machine slowly and be cautious with machine movements.

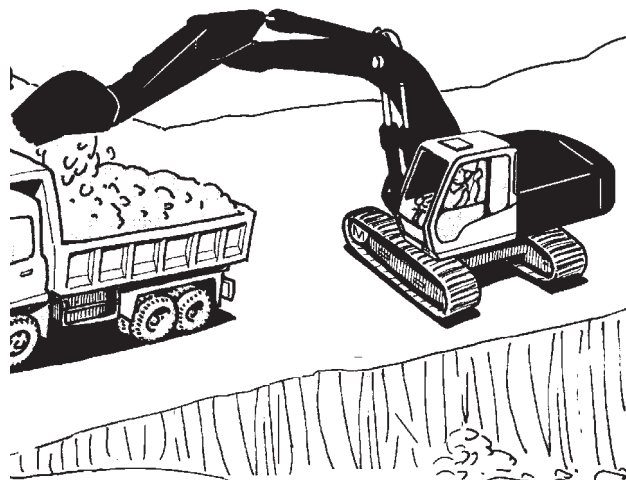

M104-05-016

### Install OPG Guard

In case the machine is operated in areas where the possibilities of falling stones or debris exist, equip Hitachi OPG guard. Consult your authorized dealer for installing the OPG guard. In order not to impair operator protective structure: Replace damaged OPG guard. Never attempt to repair or modify the guard.

OPG: Operator Protective Guard

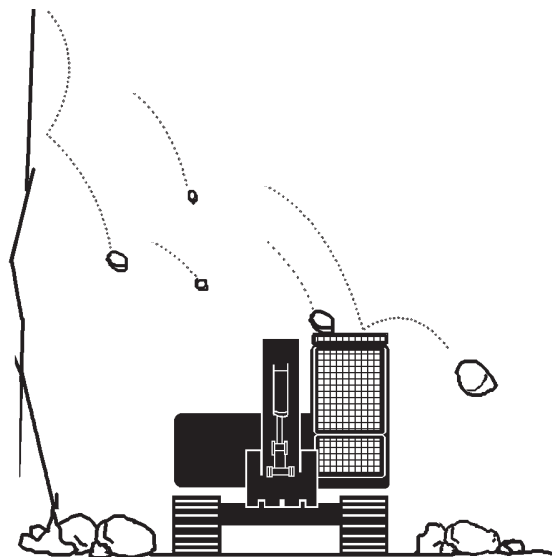

SA-490

### Restriction of Attachment Installation

Do not install an attachment which exceeds the specified weight for the machine structure.

## SAFETY

---

### Provide Signals for Jobs Involving Multiple Machines

- For jobs involving multiple machines, provide signals commonly known by all personnel involved. Also, appoint a signal person to coordinate the job site. Make sure that all personnel obey the signal person's directions.



SA-481

---

### Confirm Direction of Machine to Be Driven

- Incorrect travel pedal/lever operation may result in serious injury or death.
  - Before driving the machine, confirm the position of the undercarriage in relation to the operator's position. If the travel motors are located in front of the cab, the machine will move in reverse when travel pedals/levers are operated facing forwards.

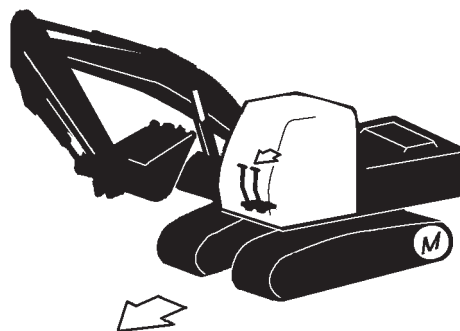

SA-491



## SAFETY

### Drive Machine Safely

- Before driving the machine, always confirm that the travel levers/pedals direction corresponds to the direction you wish to drive.
  - Be sure to detour around any obstructions.
  - Avoid traveling over obstructions. Soil, fragments of rocks, and/or metal pieces may scatter around the machine. Do not allow personnel to stay around the machine while traveling.
- Driving on a slope may cause the machine to slip or overturn, possibly resulting in serious injury or death.
  - Never attempt to ascend or descend 35 degrees or steeper slopes.
  - Be sure to fasten the seat belt.
  - When driving up or down a slope, keep the bucket facing the direction of travel, approximately 0.2 to 0.3 m (see A on the right) above the ground.
  - If the machine starts to skid or becomes unstable, immediately lower the bucket to the ground and stop.
  - Driving across the face of a slope or steering on a slope may cause the machine to skid or turnover. If the direction must be changed, move the machine to level ground, then, change the direction to ensure safe operation.

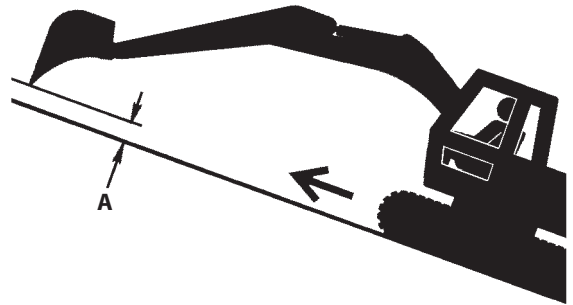

SA-657

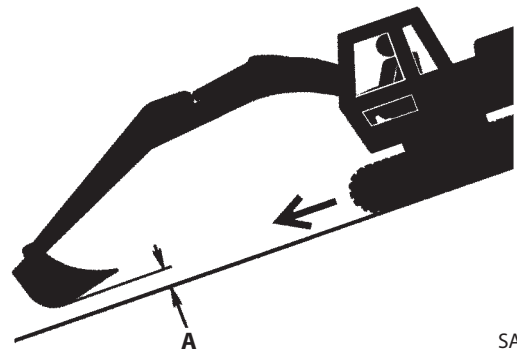

SA-658

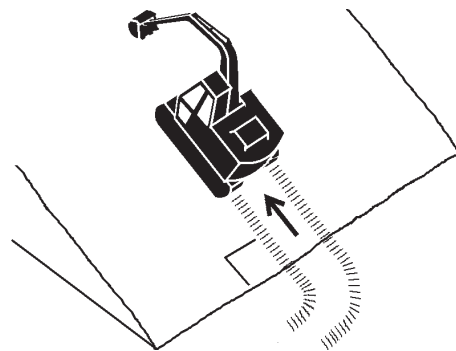

SA-441

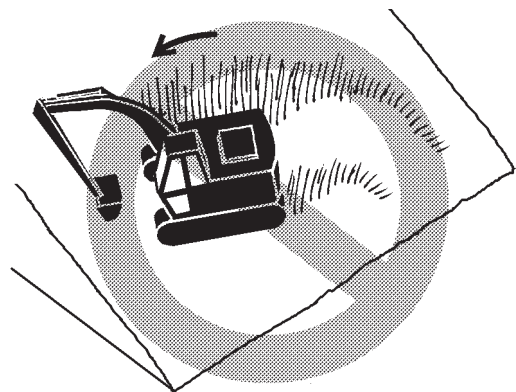

MZX5-04-002

## SAFETY

- Avoid swinging the upperstructure on slopes. Never attempt to swing the upperstructure downhill. The machine may tip over. If swinging uphill is unavoidable, carefully operate the upperstructure and boom at slow speed.
- If the engine stalls on a slope, immediately lower the bucket to the ground. Return the control levers to neutral. Then, restart the engine.
- Be sure to thoroughly warm up the machine before ascending steep slopes. If hydraulic oil has not warmed up sufficiently, sufficient performance may not be obtained.
- Use a signal person when moving, swinging or operating the machine in congested areas. Coordinate hand signals before starting the machine.
- Before moving machine, determine which way to move travel pedals/levers for the direction you want to go. When the travel motors are in the rear, pushing down on the front of the travel pedals or pushing the levers forward moves the machine forward, towards the idlers. An arrow-mark seal is stuck on the inside surface of the side frame to indicate the machine front direction.
- Select a travel route that is as flat as possible. Steer the machine as straight as possible, making small gradual changes in direction.
- Before traveling on them, check the strengths of bridges and road shoulders, and reinforce if necessary.
- Use wood plates in order not to damage the road surface. Be careful of steering when operating on asphalt roads in summer.
- When crossing train tracks, use wood plates in order not to damage them.
- Do not make contact with electric wires or bridges.
- When crossing a river, measure the depth of the river using the bucket, and cross slowly. Do not cross the river when the depth of the river is deeper than the upper edge of the upper roller.
- When traveling on rough terrain, reduce engine speed. Select slow travel speed. Slower speed will reduce possible damage to the machine.
- Avoid operations that may damage the track and undercarriage components.
- During freezing weather, always clean snow and ice from track shoes before loading and unloading the machine, to prevent the machine from slipping.



M104-05-008

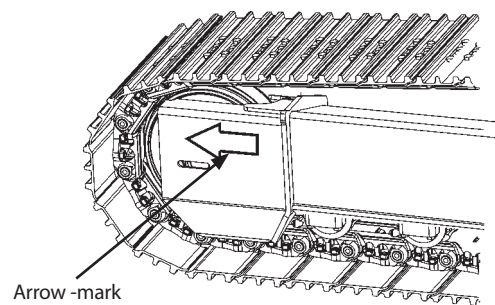

M178-03-001



SA-011

## SAFETY

---

### Avoid Injury from Rollaway Accidents

- Death or serious injury may result if you attempt to mount or stop a moving machine.

To avoid rollaways:

- Select level ground when possible to park the machine.
- Do not park the machine on a gradient.
- Lower the bucket and/or other work tools to the ground.
- Turn the auto-idle switch OFF.
- Run the engine at slow idle speed without load for 5 minutes to cool down the engine.
- Stop the engine and remove the key from the key switch.
- Pull the pilot control shut-off lever to LOCK position.
- Block both tracks and lower the bucket to the ground. Thrust the bucket teeth into the ground if you must park on a gradient.
- Position the machine to prevent rolling.
- Park at a reasonable distance from other machines.

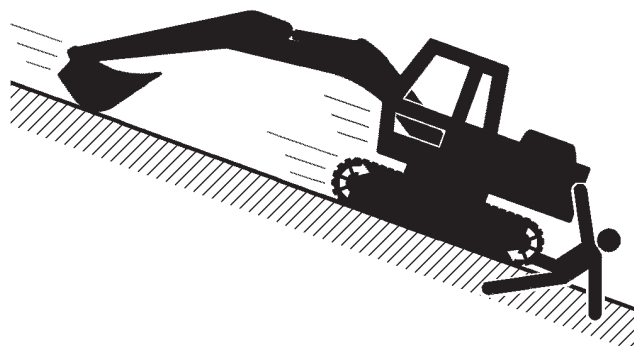

SA-391

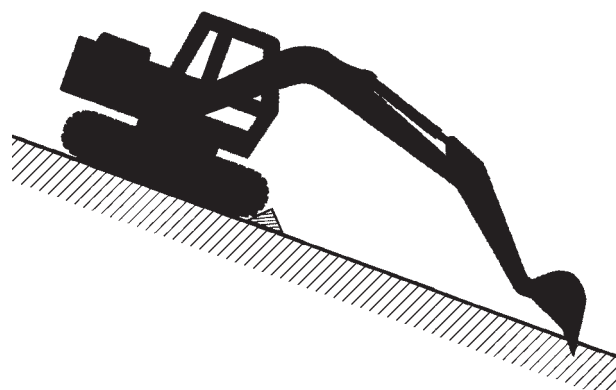

SA-2273

## SAFETY

---

### Avoid Injury from Back-Over and Swing Accidents

- If any person is present near the machine when backing or swinging the upperstructure, the machine may hit or run over that person, resulting in serious injury or death.

To avoid back-over and swing accidents:

- Always look around BEFORE YOU BACK UP AND SWING THE MACHINE. BE SURE THAT ALL BYSTANDERS ARE CLEAR.
- Keep the travel alarm in working condition (if equipped). ALWAYS BE ALERT FOR BYSTANDERS MOVING INTO THE WORK AREA. USE THE HORN OR OTHER SIGNAL TO WARN BYSTANDERS BEFORE MOVING MACHINE.
- USE A SIGNAL PERSON WHEN BACKING UP IF YOUR VIEW IS OBSTRUCTED. ALWAYS KEEP THE SIGNAL PERSON IN VIEW.

Use hand signals, which conform to your local regulations, when work conditions require a signal person.

- No machine motions shall be made unless signals are clearly understood by both signal person and operator.
- Learn the meanings of all flags, signs, and markings used on the job and confirm who has the responsibility for signaling.
- Keep windows, mirrors, and lights clean and in good condition.
- Dust, heavy rain, fog, etc., can reduce visibility. As visibility decreases, reduce speed and use proper lighting.
- Read and understand all operating instructions in the operator's manual.

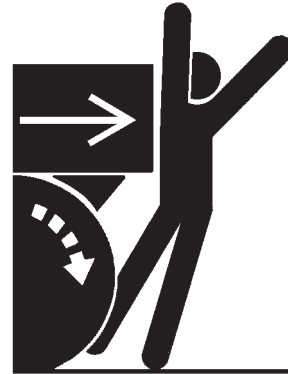

SA-383

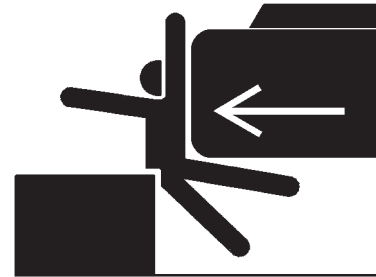

SA-384

## SAFETY

---

### Keep People Clear from Working Area

- People around the operating machine may be hit severely by the swinging front attachment or counterweight, be caught in other objects, and/or be struck by flying objects, resulting in serious injury or death.
- Set up barriers and/or put a "NO ADMISSION" sign at the machine operating site and areas exposed by flying objects to prevent anyone from entering the work area.
- Before operating the machine, set up barriers to the sides and rear area of the bucket swing radius to prevent anyone from entering the work area.

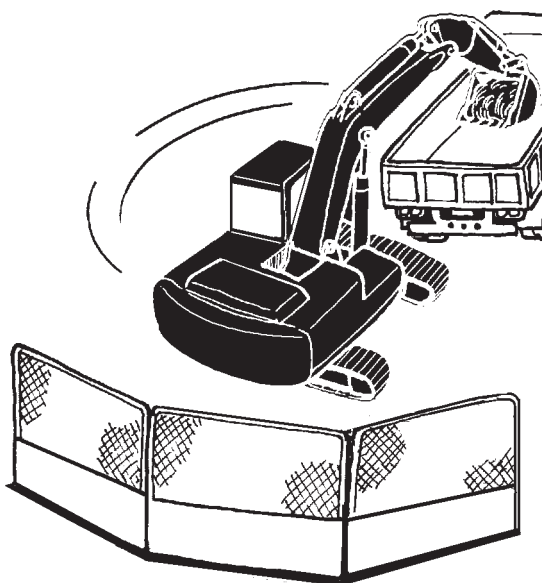

SA-386

### Never Position the Bucket Over Anyone

- Never lift, move, or swing the bucket above anyone or above the truck cab. Serious injury or machine damage may result due to bucket load spill or due to collision with the bucket.



SA-487

## SAFETY

### Avoid Undercutting

- In order to retreat from the edge of an excavation if the footing should collapse, always position the undercarriage perpendicular to the edge of the excavation with the travel motors at the rear.
- If the footing starts to collapse and if retreat is not possible, do not panic. Often, the machine can be secured by lowering the front attachment, in such cases.

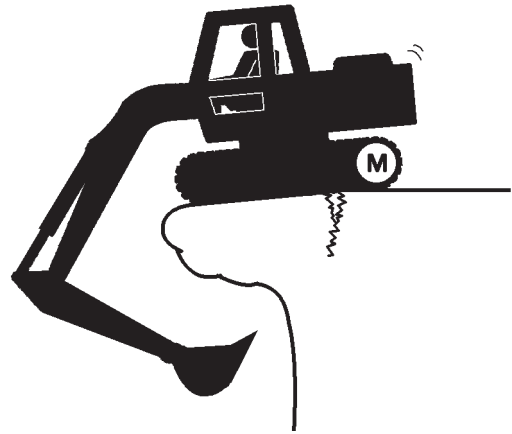

SA-488

### Avoid Tipping

**DO NOT ATTEMPT TO JUMP CLEAR OF TIPPING MACHINE  
--- SERIOUS OR FATAL CRUSHING INJURIES WILL RESULT**

**MACHINE WILL TIP OVER FASTER THAN YOU CAN JUMP  
FREE**

**FASTEN YOUR SEAT BELT**

- The danger of tipping is always present when operating on a grade, possibly resulting in serious injury or death. To avoid tipping:
- Be extra careful before operating on a gradient.
  - Prepare machine operating area flat.
  - Keep the bucket low to the ground and close to the machine.
  - Reduce operating speeds to avoid tipping or slipping.
  - Avoid changing direction when traveling on grades.
  - NEVER attempt to travel across a grade steeper than 15 degrees if crossing the grade is unavoidable.
  - Reduce swing speed as necessary when swinging loads.
- Be careful when working on frozen ground.
  - Temperature increases will cause the ground to become soft and make ground travel unstable.

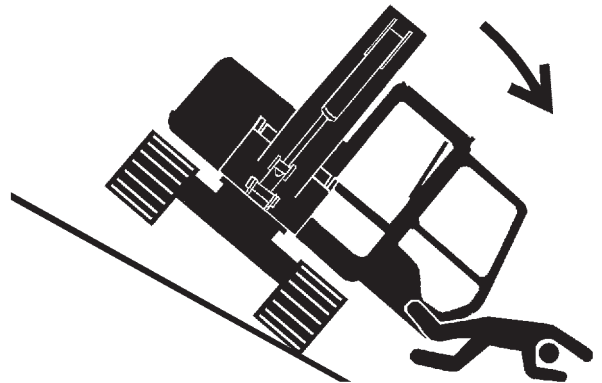

SA-012

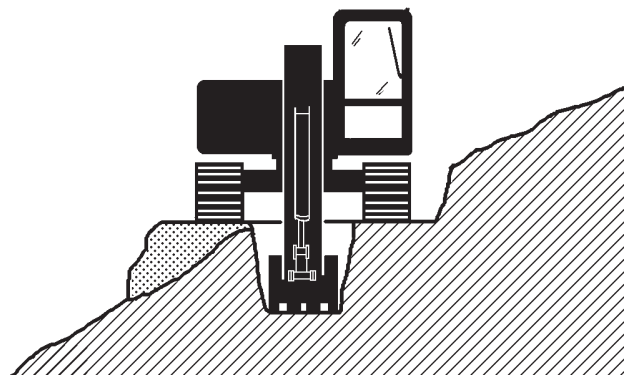

SA-440

## SAFETY

---

### Never Undercut a High Bank

- The edges could collapse or a land slide could occur causing serious injury or death.



SA-489

### Dig with Caution

- Accidental severing of underground cables or gas lines may cause an explosion and/or fire, possibly resulting in serious injury or death.
  - Before digging check the location of cables, gas lines, and water lines.
  - Keep the minimum distance required, by law, from cables, gas lines, and water lines.
  - If a fiber optic cable should be accidentally severed, do not look into the end. Doing so may result in serious eye injury.
  - Contact your local "diggers hot line" if available in your area, and/or the utility companies directly. Have them mark all underground utilities.



SA-382

### Operate with Caution

- If the front attachment or any other part of the machine hits against an overhead obstacle, such as a bridge, both the machine and the overhead obstacle will be damaged, and personal injury may result as well.
  - Take care to avoid hitting overhead obstacles with the boom or arm.



SA-389

## SAFETY

---

### Avoid Power Lines

- Serious injury or death can result if the machine or front attachments are not kept a safe distance from electric lines.
- When operating near an electric line, never move any part of the machine or load to within 3 m plus twice the line insulator length of overhead wires.
- Check and comply with any local regulations that may apply.
- Wet ground will expand the area that could cause any person on it to be affected by electric shock. Keep all bystanders or co-workers away from the site.

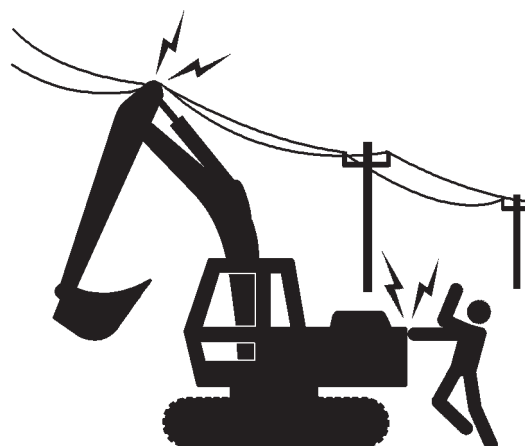

SA-381

---

### Precautions for Lightning

- Lightning may strike the machine.

If lightning comes close, immediately stop the operation, and take the following action.

- When you are around the machine or operating cab-less machine, evacuate to a safe place far away from the machine.
- When you are in the cab, stay in the cab until lightning has passed and safety is assured. Close the cab doors and windows. Lower the bucket to the ground, and stop the engine. Put your hands on your lap to avoid contact with any metal surfaces. Never go out of the cab.

If lightning strikes the machine or near the machine, check all of the machine safety devices for any failure after lightning has passed and safety is assured. If any trouble is found, operate the machine only after repairing it.



SA-2715



## SAFETY

---

### Object Handling

- If a lifted load should fall, any person nearby may be struck by the falling load or may be crushed underneath it, resulting in serious injury or death.
  - When using the machine for craning operations, be sure to comply with all local regulations.
  - Do not use damaged chains or frayed cables, slings, or ropes.
  - Before craning, position the upperstructure with the travel motors at the rear.
  - Move the load slowly and carefully. Never move it suddenly.
  - Keep all persons well away from the load.
  - Never move a load over a person's head.
  - Do not allow anyone to approach the load until it is safely and securely situated on supporting blocks or on the ground.
  - Never attach a sling or chain to the bucket teeth. They may come off, causing the load to fall.

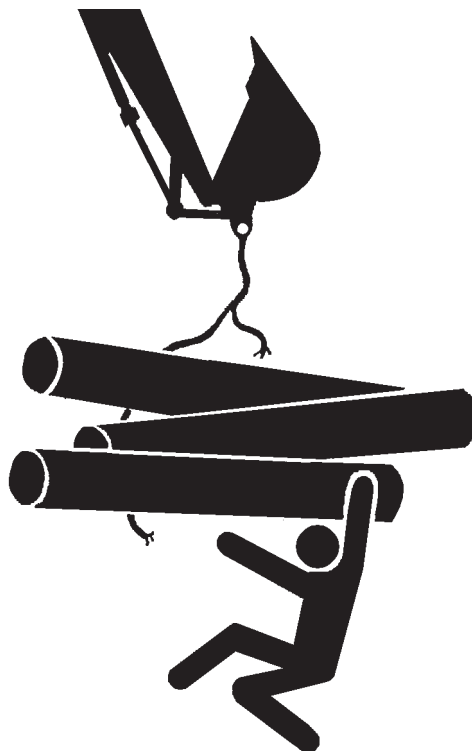

SA-014

## SAFETY

---

### Protect Against Flying Debris and Falling Object

- During hammer operation, debris from earth, rock or metal may fly in all directions, resulting in a serious personal injury or death.
  - When driving the connecting pins in or out, wear goggles or safety glasses, hard hat and face shield.

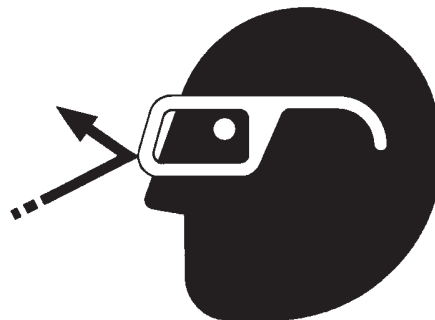

SA-432

- During machine operation, debris from earth, rock or metal may fly off from the track and bucket, resulting in a serious personal injury or death.
  - Ensure nobody presents in or around the work area while machine is operating.



SA-344

- Falling of accumulated earth or dirt onto people may result in a serious personal injury or death.
  - Before performing maintenance or inspection under carriage, remove accumulated debris.



SA-527

## SAFETY

---

### Park Machine Safely

To avoid accidents:

- Park machine on a firm, level surface.
- Lower the bucket and blade to the ground.
- Turn auto-idle switch OFF.
- Run engine at slow idle speed without load for 5 minutes.
- Turn key switch to OFF to stop engine.
- Remove the key from the key switch.
- Pull the pilot control shut-off lever to the LOCK position.
- Close windows, roof vent, and cab door.
- Lock all access doors and compartments.



SA-2590

### Handle Fluids Safely—Avoid Fires

- Handle fuel with care; it is highly flammable. If fuel ignites, an explosion and/or a fire may occur, possibly resulting in serious injury or death.
  - Do not refuel the machine while smoking or when near open flame or sparks.
  - Always stop the engine before refueling the machine.
  - Fill the fuel tank outdoors.
- All fuels, most lubricants, and some coolants are flammable.
  - Store flammable fluids well away from fire hazards.
  - Do not incinerate or puncture pressurized containers.
  - Do not store oily rags; they can ignite and burn spontaneously.
  - Securely tighten the fuel and oil filler caps.



SA-018



SA-019

## SAFETY

---

### Transport Safely

- Take care the machine may turn over when loading or unloading the machine onto or off of a truck or trailer.
  - Observe the related regulations and rules for safe transportation.
  - Select an appropriate truck or trailer for the machine to be transported.
  - Be sure to use a signal person.
  - Always follow the following precautions for loading or unloading:
    1. Select solid and level ground.
    2. Always use a ramp or deck strong enough to support the machine weight.
    3. Turn auto-idle switch OFF.
    4. Always select the slow speed mode with the travel mode switch.
    5. Never load or unload the machine onto or off a truck or trailer using the front attachment functions when driving up or down the ramp.
    6. Never steer the machine while on the ramp. If the traveling direction must be changed while on the ramp, unload the machine from the ramp, reposition the machine on the ground, then try loading again.
    7. At the top end of the ramp where it meets the flatbed, there is a sudden bump. Take care when traveling over it.
    8. Place blocks in front of and behind the tires. Securely fasten the machine to the truck or trailer deck with wire ropes.



SA-395

Be sure to further follow the details described in the "TRANSPORTING" section.

## SAFETY

---

### Practice Safe Maintenance

To avoid accidents:

- Understand service procedures before starting work.
- Keep the work area clean and dry.
- Do not spray water or steam inside cab.
- Never lubricate or service the machine while it is moving.
- Keep hands, feet and clothing away from power-driven parts.

Before servicing the machine:

1. Park the machine on a level surface.
2. Lower the bucket to the ground.
3. Turn the auto-idle switch off.
4. Run the engine at slow idle speed without load for 5 minutes.
5. Turn the key switch to OFF to stop engine.
6. Relieve the pressure in the hydraulic system by moving the control levers several times.
7. Remove the key from the key switch.
8. Attach a "Do Not Operate" tag on the control lever.
9. Pull the pilot control shut-off lever to the LOCK position.
10. Allow the engine to cool.

- If a maintenance procedure must be performed with the engine running, do not leave the machine unattended.
- If the machine must be raised, maintain a 90 to 110° angle between the boom and arm. Securely support any machine elements that must be raised for service work.
- Inspect certain parts periodically and repair or replace as necessary. Refer to the section discussing that part in the "MAINTENANCE" chapter of this manual.
- Keep all parts in good condition and properly installed.
- Fix damage immediately. Replace worn or broken parts. Remove any buildup of grease, oil, or debris.
- When cleaning parts, always use nonflammable detergent oil. Never use highly flammable oil such as fuel oil and gasoline to clean parts or surfaces.
- Turn the battery disconnect switch to OFF before adjusting the electrical systems or performing welding on the machine.



SA-028



SA-527

## SAFETY

---

- Sufficiently illuminate the work site. Use a maintenance work light when working under or inside the machine.
- Always use a work light protected with a guard. If the light bulb is broken, spilled fuel, oil, antifreeze fluid, or window washer fluid may catch fire.



SA-037

---

### Warn Others of Service Work

- Unexpected machine movement can cause serious injury.
  - Before performing any work on the machine, attach a “Do Not Operate” tag on the control lever. This tag is available from your authorized dealer.

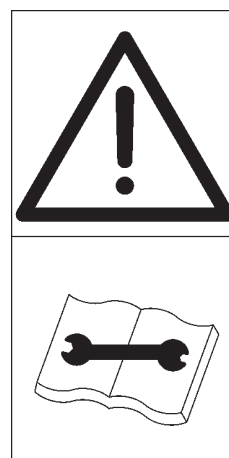

SS2045102-4

---

### Support Machine Properly

- Never attempt to work on the machine without securing the machine first.
  - Always lower the attachment to the ground before you work on the machine.
  - If you must work on a lifted machine or attachment, securely support the machine or attachment. Do not support the machine on cinder blocks, hollow tires, or props that may crumble under continuous load. Do not work under a machine that is supported solely by a jack.



SA-527

## SAFETY

---

### Stay Clear of Moving Parts

- Entanglement in moving parts can cause serious injury.
  - To prevent accidents, care should be taken to ensure that hands, feet, clothing, jewelry and hair do not become entangled when working around rotating parts.

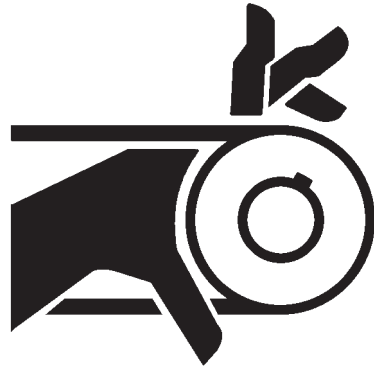

SA-026

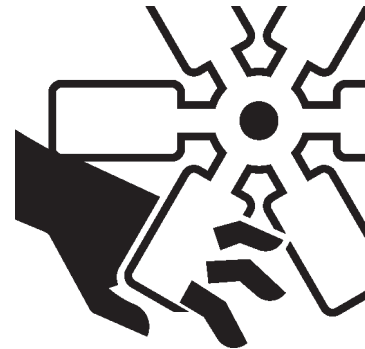

SA-2294

---

### Prevent Parts from Flying

- Grease in the track adjuster is under high pressure. Failure to follow the precautions below may result in serious injury, blindness, or death.
  - Do not attempt to remove GREASE FITTING or VALVE ASSEMBLY.
  - Do not attempt to remove the valve stop plate.
  - As pieces may fly off, be sure to keep body and face away from valve.
  - Never attempt to disassemble the track adjuster. Inadvertent disassembling of the track adjuster may cause the parts such as a spring to fly off, possibly resulting in severe personal injury or death.
- Travel reduction gears are under pressure.
  - As pieces may fly off, be sure to keep body and face away from AIR RELEASE PLUG to avoid injury.
  - GEAR OIL is hot. Wait for GEAR OIL to cool, then gradually loosen AIR RELEASE PLUG to release pressure.



SA-344

## SAFETY

---

### Avoid Injury from Attachment Falling Accident

- Stored attachments such as buckets, hydraulic hammers, and blades can fall and cause serious injury or death.
  - To avoid possible personal injury from attachment falling accident, use a platform when replacing an attachment.
  - Securely store attachments such as a bucket, blade, breaker and other parts to prevent falling.
  - Keep children and bystanders away from attachment storage areas.

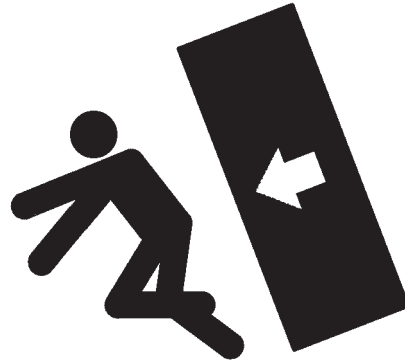

SA-034

---

### Prevent Burns

Hot spraying fluids:

- After operation, engine coolant is hot and under pressure. Hot water or steam is contained in the engine, expansion tank and heater lines. Skin contact with escaping hot water or steam can cause severe burns.
  - Avoid possible injury from hot spraying water. DO NOT remove the expansion tank cap until the engine is cool. When opening, turn the cap slowly to the stop. Allow all pressure to be released before removing the cap.
  - The hydraulic oil tank is pressurized. Again, be sure to release all pressure before removing the cap.



SA-039

Hot fluids and surfaces:

- Engine oil, gear oil and hydraulic oil also become hot during operation. The engine, hoses, lines and other parts become hot as well.
  - Wait for the oil and components to cool before starting any maintenance or inspection work.



SA-225



## SAFETY

### Replace Rubber Hoses Periodically

- Rubber hoses that contain flammable fluids under pressure may break due to aging, fatigue, and abrasion. It is very difficult to gauge the extent of deterioration due to aging, fatigue, and abrasion of rubber hoses by inspection alone.
  - Periodically replace the rubber hoses. (See the page of "Periodic replacement of parts" in the operator's manual.)
- Failure to periodically replace rubber hoses may cause a fire, fluid injection into skin, or the front attachment to fall on a person nearby, which may result in severe burns, gangrene, or otherwise serious injury or death.



SA-019

### Avoid High-Pressure Fluids

- Fluids such as diesel fuel or hydraulic oil under pressure can penetrate the skin or eyes causing serious injury, blindness or death.
  - Avoid this hazard by relieving pressure before disconnecting hydraulic or other lines.
  - Tighten all connections before applying pressure.
  - Search for leaks with a piece of cardboard; take care to protect hands and body from high-pressure fluids. Wear a face shield or goggles for eye protection.
  - If an accident occurs, see a doctor familiar with this type of injury immediately. Any fluid injected into the skin must be surgically removed within a few hours or gangrene may result.

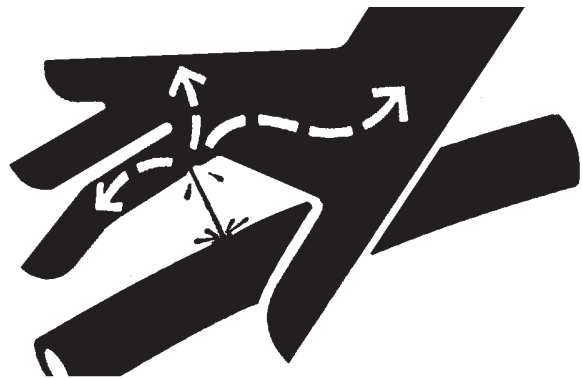

SA-031

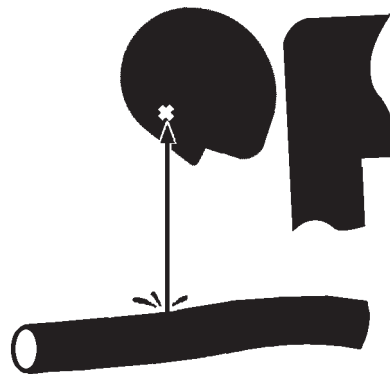

SA-292

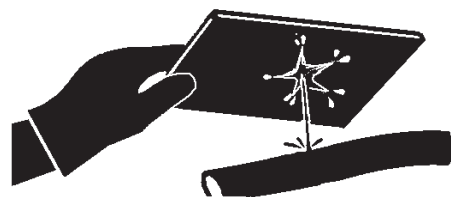

SA-044

## SAFETY

---

### Prevent Fires

Check for Oil Leaks:

- Fuel, hydraulic oil and lubricant leaks can lead to fires.
  - Check for oil leaks due to missing or loose clamps, kinked hoses, lines or hoses that rub against each other, damage to the oil cooler, and loose oil cooler flange bolts.
  - Tighten, repair or replace any missing, loose or damaged clamps, lines, hoses, oil cooler and oil cooler flange bolts.
  - Do not bend or strike high-pressure lines.
  - Never install bent or damaged lines, pipes, or hoses.
  - Replace fuel hoses and hydraulic hoses periodically even if there is no abnormality in their external appearance.



SA-019

Check for Shorts:

- Short circuits can cause fires.
  - Clean and tighten all electrical connections.
  - Check before each shift or after eight (8) to ten (10) hours operation for loose, kinked, hardened or frayed electrical cables and wires.
  - Check before each shift or after eight (8) to ten (10) hours operation for missing or damaged terminal caps.
  - **DO NOT OPERATE MACHINE** if cable or wires are loose, kinked, etc.
  - Never attempt to modify electric wirings.

## SAFETY

---

### Clean up Flammable Materials:

- Spilled fuel and oil, trash, grease, debris, accumulated coal dust, and other flammable materials may cause fires.
  - Prevent fires by inspecting and cleaning the machine daily, and by removing adhered oil or accumulated flammable materials immediately. Check and clean high temperature parts such as the exhaust outlet and muffler earlier than the normal interval.
  - Do not wrap high temperature parts such as a muffler or exhaust pipe with oil absorbents.
  - Do not store oily cloths as they are vulnerable to catching fire.
  - Keep flammable materials away from open flames.
  - Do not ignite or crush a pressurized or sealed container.
  - Wire screens may be provided on openings on the engine compartment covers to prevent flammable materials such as dead leaves from entering. However, flammable materials which have passed through the wire screen may cause fires. Check and clean the machine every day and immediately remove accumulated flammable materials.

### Check Key Switch:

- If a fire breaks out, failure to stop the engine will escalate the fire, hampering fire fighting.
  - Always check key switch function before operating the machine every day:
    1. Start the engine and run it at slow idle.
    2. Turn the key switch to the OFF position to confirm that the engine stops.
  - If any abnormalities are found, be sure to repair them before operating the machine.

### Check Heat Shields:

- Damaged or missing heat shields may lead to fires.
  - Damaged or missing heat shields must be repaired or replaced before operating the machine.
  - If hydraulic hoses are broken while the engine cover is open, splattered oil on the high temperature parts such as muffler may cause fire. Always close the engine cover while operating the machine.

## SAFETY

### Evacuating in Case of Fire

- If a fire breaks out, evacuate the machine in the following way:
  - Stop the engine by turning the key switch to the OFF position if there is time.
  - Use a fire extinguisher if there is time.
  - Exit the machine.
- In an emergency, if the cab door or front window can not be opened, break the front or rear window pane with the emergency evacuation hammer to escape from the cab. Refer to the explanation pages on the Emergency Evacuation Method.



SA-393



SS-1510

### Beware of Exhaust Fumes

- Prevent asphyxiation. Engine exhaust fumes can cause sickness or death.
  - If you must operate in a building, be sure there is adequate ventilation. Either use an exhaust pipe extension to remove the exhaust fumes or open doors and windows to bring enough outside air into the area.
  - White smoke may be generated during the aftertreatment device regeneration. Do not attempt to do aftertreatment device manual regeneration in a badly ventilated indoors.

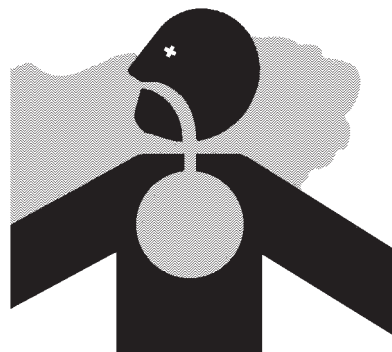

SA-016

## SAFETY

---

### Precautions for Welding and Grinding

- Welding may generate gas and/or small fires.
  - Be sure to perform welding in a well ventilated and prepared area. Store flammable materials in a safe place before starting welding.
  - Only qualified personnel should perform welding. Never allow an unqualified person to perform welding.
  - Turn the battery disconnect switch to the OFF position before performing welding on the machine.
- Grinding on the machine may create fire hazards. Store flammable materials in a safe place before starting grinding.
- After finishing welding and grinding, recheck that there are no abnormalities such as the area surrounding the welded area still smoldering.



SA-818

## SAFETY

---

### Avoid Heating Near Pressurized Fluid Lines

- Flammable spray can be generated by heating near pressurized fluid lines, resulting in severe burns to yourself and bystanders.
- Do not heat by welding, soldering, or using a torch near pressurized fluid lines or other flammable materials.
- Pressurized lines can be accidentally cut when heat goes beyond the immediate flame area. Install temporary fire-resistant guards to protect hoses or other materials before engaging in welding, soldering, etc.



SA-030

### Avoid Applying Heat to Lines Containing Flammable Fluids

- Do not weld or flame cut pipes or tubes that contain flammable fluids.
- Clean pipes and tubes thoroughly with non-flammable solvent before welding or flame cutting.

---

### Precautions for Handling Accumulator and Gas Damper

High-pressure nitrogen gas is sealed in the accumulator and the gas damper. Inappropriate handling may cause explosion, possibly resulting in serious injury or death.

Strictly comply with the following items:

- Do not disassemble the unit.
- Keep the units away from open flames and fire.
- Do not bore a hole, do not cut by torch.
- Avoid giving shocks by hitting or rolling the unit.
- Before disposing of the unit, sealed gas must be released. Consult your authorized dealer.

## SAFETY

---

### Remove Paint Before Welding or Heating

- Hazardous fumes can be generated when paint is heated by welding, soldering, or using a torch. If inhaled, these fumes may cause sickness.
  - Avoid potentially toxic fumes and dust.
  - Do all such work outside or in a well-ventilated area. Dispose of paint and solvent properly.
  - Remove paint before welding or heating:
    1. If you sand or grind paint, avoid breathing the dust. Wear an approved respirator.
    2. If you use solvent or paint stripper, remove stripper with soap and water before welding. Remove solvent or paint stripper containers and other flammable materials from area. Allow fumes to disperse at least 15 minutes before welding or heating.



SA-029

### Beware of Asbestos and Silica Dust and Other Contamination

- Take care not to inhale dust produced in the work site. Inhalation of asbestos fibers may be the cause of lung cancer. Inhalation of silica dust or other contaminations may cause sickness.
  - Depending on the work site conditions, the risk of inhaling asbestos fiber, silica dust or other contaminations may exist. Spray water to prevent asbestos fibers, silica dust or other contaminations from becoming airborne. Do not use compressed air.
  - When operating the machine in a work site where asbestos fibers, silica dust or other contaminations might be present, be sure to operate the machine upwind, and wear a mask rated to prevent the inhalation of asbestos, silica dust or other contaminations.
  - Keep bystanders out of the work site during operation.
  - Asbestos fibers might be present in imitation parts. Use only genuine Hitachi Parts.



SA-029

## SAFETY

---

### Prevent Battery Explosions

- Battery gas can explode.
  - Keep sparks, lighted matches, and flame away from the top of battery.
  - Never check battery charge by placing a metal object across the posts. Use a voltmeter or hydrometer.
  - Do not charge a frozen battery; it may explode. Warm the battery to 16 °C ( 60 °F ) first.
  - Do not continue to use or charge the battery when electrolyte level is lower than specified. Explosion of the battery may result.
  - Loose terminals may produce sparks. Securely tighten all terminals.
  - Connect terminals to the correct electrical poles. Failure to do so may cause damage to the electrical parts or fire.
- Battery electrolyte is poisonous. If the battery should explode, battery electrolyte may be splashed into eyes, possibly resulting in blindness.
  - Be sure to wear eye protection when checking electrolyte specific gravity.



SA-032

---

### Service Air Conditioning System Safely

- If spilled onto skin, refrigerant may cause a cold contact burn.
  - Refer to the instructions described on the container for proper use when handling the refrigerant.
  - Use a recovery and recycling system to avoid leaking refrigerant into the atmosphere.
  - Never touch the refrigerant.



SA-405



## SAFETY

---

### Handle Chemical Products Safely

- Direct exposure to hazardous chemicals can cause serious injury. Potentially hazardous chemicals used with your machine include such items as lubricants, coolants, paints, and adhesives.
  - Safety Data Sheet (SDS) provides specific details on chemical products: physical and health hazards, safety procedures, and emergency response techniques.
  - Check the SDS before you start any job using a hazardous chemical. That way you will know exactly what the risks are and how to do the job safely. Then follow procedures and use recommended equipment.
  - See your authorized dealer for SDS's (available only in English) on chemical products used with your machine.



SA-2579

---

### Dispose of Waste Properly

- Improperly disposing of waste can threaten the environment and ecology. Potentially harmful waste used with Hitachi equipment includes such items as oil, fuel, coolant, DEF/AdBlue®, brake fluid, filters, and batteries.
  - Use leakproof containers when draining fluids. Do not use food or beverage containers that may mislead someone into drinking from them.
  - Do not pour waste onto the ground, down a drain, or into any water source.
  - Air conditioning refrigerants escaping into the air can damage the Earth's atmosphere. Government regulations may require a certified air conditioning service center to recover and recycle used air conditioning refrigerants.
  - Inquire on the proper way to recycle or dispose of waste from your local environmental or recycling center, or from your authorized dealer.

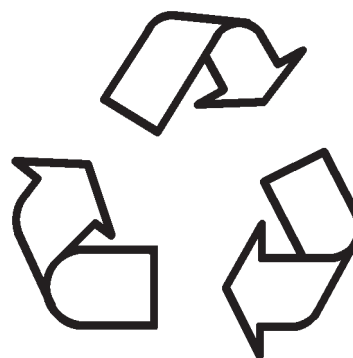

SA-226

## SAFETY

---

### Never Ride Attachment

Never allow anyone to ride on attachments or the load. This is an extremely dangerous practice.

---

### Notes on Aftertreatment Device

#### About Aftertreatment Device

The aftertreatment device removes particulate matter (PM) and NO<sub>x</sub> (Nitrogen Oxide) from the exhaust gas. Follow the instructions below to prevent the aftertreatment device from being damaged.

**⚠ WARNING: Exhaust gas from the aftertreatment device, muffler, exhaust piping and tail piping becomes hot during and right after engine running and regeneration of aftertreatment device. Keep away from the exhaust system or hot gas from the exhaust piping during regeneration. Be careful to avoid skin contact with exhaust gas. It may cause severe burns.**

- White smoke may be generated during aftertreatment device regeneration. Do not attempt to perform aftertreatment device manual regeneration in a badly ventilated area.
- Do not touch water coming directly out of the aftertreatment device. The water is mildly-acidic by oxidation catalyst mounted in the aftertreatment device. If filter water spills on your skin, immediately flush it out with clean water.

---

### Precautions for Communication Terminal

Electrical wave transmitted from the communication terminal may cause malfunction of other electronic devices. Inquire to the device manufacturer for information on electrical wave disturbance when using an electronic device near the communication terminal.

## SAFETY

---

### Precautions for Communication Terminal Equipment

This machine is installed with a communication terminal emitting radio waves behind the operator's seat. There is a possibility that a medical device, including an implantable device such as a cardiac pacemaker, could be affected and malfunction due to the electrical waves emitted from the communication terminal.

For those who uses medical devices as above should adjust the operator's seat position to keep the distance between medical device and the communication terminal are at least 15 centimeters (6 inches) at all times. If this condition cannot be met, please contact your authorized dealer and have the person in charge stop the communication terminal from functioning completely and confirm that no radio waves are emitted before operating the machine.

The effect of radio waves from communication terminal on the human body can be evaluated by measuring Specific Absorption Rate ("SAR"), which is a measure of the amount of radio frequency energy absorbed by the body when using a wireless application such as a mobile phone.

All communication terminal installed in this machine comply with technical standards and international guidelines regarding the absorption of radio waves by the human body.

There are two SAR measurement method and the safety standards, 2.0 W/kg (measured by 10 g per unit) and 1.6 W/kg (measured by 1 g per unit), either one is adopted depending on the country.

This machine is equipped with a communication terminal model HPRO-100, HPRO-4G, or QConnect. Consult your authorized dealer for the model of communication terminal.

Specific Absorption Rate ("SAR") of communication terminal.  
The values in ( ) are based on Taiwanese regulations.

	HPRO-100	HPRO-4G*	QConnect*
1.6 W/kg (1 g/unit)	0.51 W/kg	0.91 W/kg	-
2.0 W/kg (10 g/unit)	0.12 W/kg	0.50 W/kg (0.31 W/kg)	- (0.25 W/kg)

This data was measured by having each type of communication terminal used with this machine, and a human body set apart by 3 centimeters (1.18 inches).

Precautions in Taiwan\*: Under the Taiwanese regulations, the maximum SAR value is set as the standard value 2 W/kg. The actual measurement value is 0.25 W/kg using QConnect, and 0.31 W/kg using HPRO-4G.

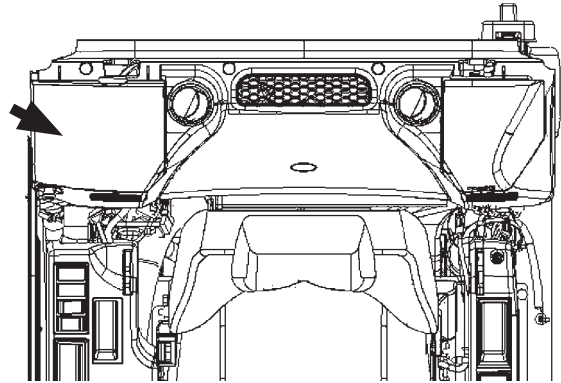

SA-2346

## SAFETY

---

- Do not attempt to disassemble, repair, modify and displace of the communication terminal, antenna and cables. Failure to do so may cause damage or fire on the machine and the communication terminal. (Before removing or installing the communication terminal, consult your authorized dealer.)
- Do not pinch or forcibly pull cables, cords and connectors. Failure to do so may cause damage or fire on the machine and the communication terminal due to short/broken circuit.

## SAFETY

### Notes on Protection of Operator's Station when the Machine Rolls Over

The cab corresponds to the structure to protect the operator by absorbing impact energy when the machine rolls over (Roll-Over Protective Structure (ROPS)).

However, when modifying the machine or installing a special attachment causing the machine mass to exceed the maximum operating mass described in the ROPS certification, the cab cannot fulfill its protective function, possibly causing serious injury or death.

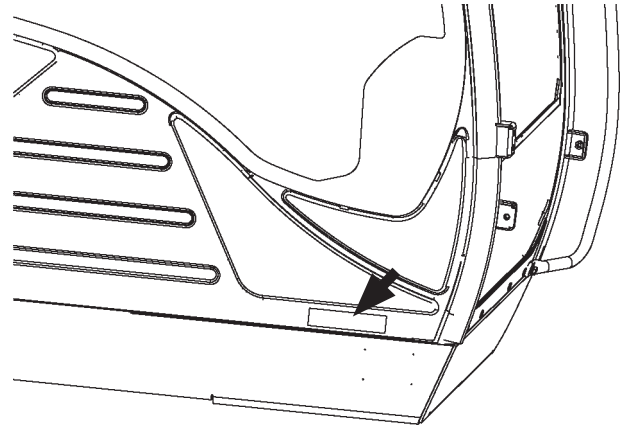

SS-3636

In order to safeguard the protective structure, follow the instructions below.

- Consult your authorized dealer before welding parts or drilling a hole on the cab, which possibly reduces the cab strength.
- Be sure to always fasten the seat belt when operating the machine. If the machine rolls over without operator fastening the seat belt, the operator may become injured, may be thrown out from the cab and/or may become crushed under the machine even though the cab has the protective structure.

The ROPS certification is valid under the following conditions.

- The machine mass is lower than the maximum operating mass described in the ROPS certification.
- The ROPS is properly installed.
- No modification is made to the ROPS.
- The ROPS is free from damage.

Applicable Machine Model Number

Maximum operating mass assuring the ROPS

<p>転倒時保護構造物 (ROPS) 証明書 ROPS CERTIFICATION</p> <p>車両モデル番号 MACHINE MODEL NO.</p> <div style="border: 1px solid black; height: 40px; width: 100%;"></div>	<p>ROPS ISO 12117-2:2008</p> <p>最大運転質量 MAX. OPERATING MASS</p> <p>ROPS <input style="width: 50px;" type="text"/> kg</p>
<p>日立建機株式会社 茨城県土浦市神立町650番地</p>	<p>ROPS 証明書番号 CERTIFICATION NO.</p> <div style="border: 1px solid black; height: 20px; width: 100%;"></div> <p>ROPS モデル番号 ROPS MODEL NO.</p> <div style="border: 1px solid black; height: 20px; width: 100%;"></div>

Hitachi Construction Machinery Co., Ltd.  
650, Kandatsu-machi, Tsuchiura-shi, Ibaraki-ken, Japan

Certificate number of the ROPS

ROPS Model Number

SS-3944

# VISIBILITY MAP

## Visibility Map for Machine Model ZX135US-6

### Personal Hazard

This machine complies with the essential health and safety requirements for visibility set out by Machinery Directive 2006/42/EC. This map is intended to provide information on the residual maskings (blind spots) applicable to the machine position(s) as shown, observed by a seated operator (wearing the recommended seat restraint) in the cab, using direct vision and the standard visual aids supplied with the machine. Operators are encouraged to adjust the mirrors installed on the machine to show the area as shown below.

Visibility maps provide an approximation of the residual masking to be anticipated. It can be used as a guide when conducting a site risk assessment, utilized for site management and to consider additional visual aids where needed.

### Conditions: Driver's visibility on 1 mRB and VTC are evaluated under ISO 5006.

Test Height (on 1 mRB):	1.2 m to 1.5 m
(1 mRB to VTC/on VTC):	Ground Level
Operator eye Height:	1.2 m from the cab floor
Machine Configuration:	Monoblock Boom
Machine Position:	Travel Position (For the detail position, see the image below)
Applicable visual aids:	<ol style="list-style-type: none"> <li>1. Standard mirror (s)</li> <li>2. Standard rear view camera</li> <li>3. Standard side view camera</li> </ol>



Machine Position Image

MDAT-VM-035

- ⊗ : Operator's eye point
- A : 1m Rectangular Boundary (1mRB)
- B : 12m Visibility Test Circle (VTC)
- ⊖ : Standard Mirror(s)
- ⊕ : Standard rear view camera
- ⊙ : Standard side view camera

- : Masking area
- : Mirror visibility
- : Camera visibility
- : Masking on 1mRB / VTC

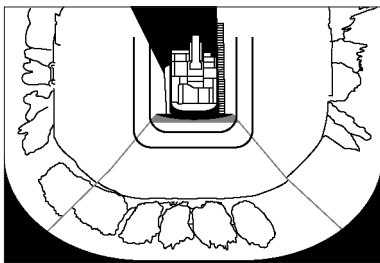

Monitor screen

MDC1-VM-039EN

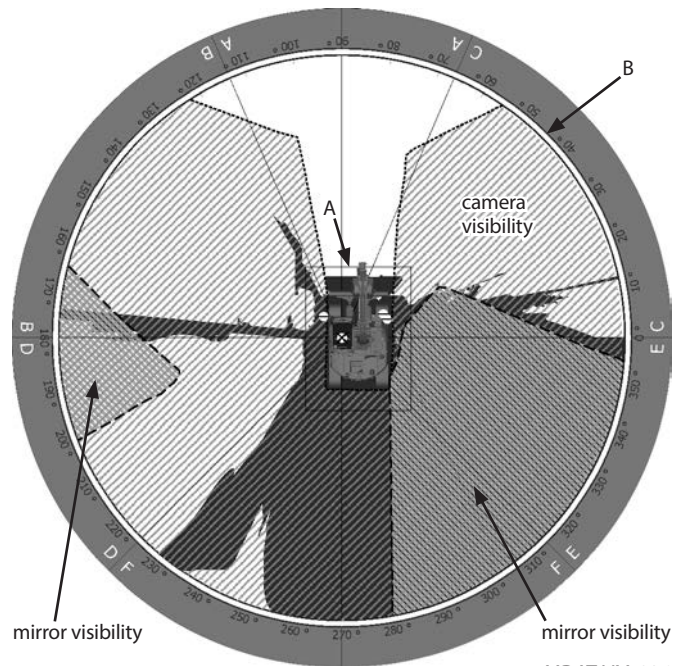

Visibility Map  
Image around machine

MDAT-VM-036



# VISIBILITY MAP

- ⊗ : Operator's eye point
- A : 1m Rectangular Boundary (1mRB)
- B : 12m Visibility Test Circle (VTC)
- ⊖ : Standard Mirror(s)
- ⊙ : Standard rear view camera
- ⊕ : Standard side view camera
- : Masking area
- ▨ : Mirror visibility
- ▩ : Camera visibility
- : Masking on 1mRB / VTC

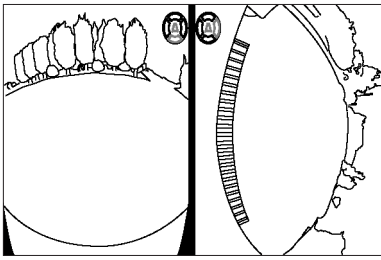

Monitor screen

MDC1-VM-040EN

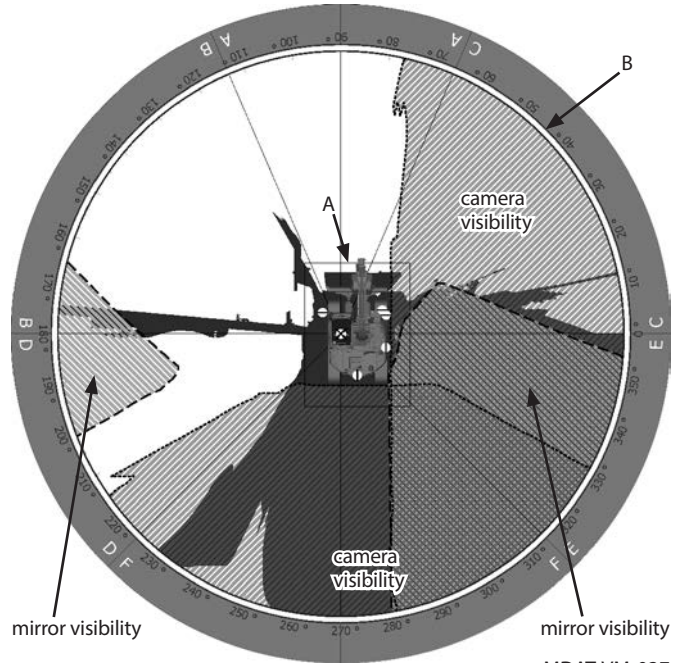

mirror visibility

Visibility Map

Image behind, image on right of machine

MDAT-VM-037

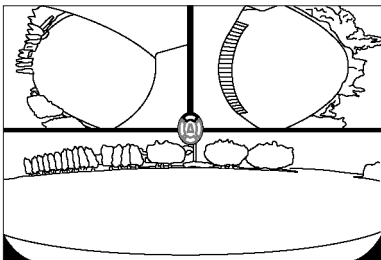

Monitor screen

MDC1-VM-041EN

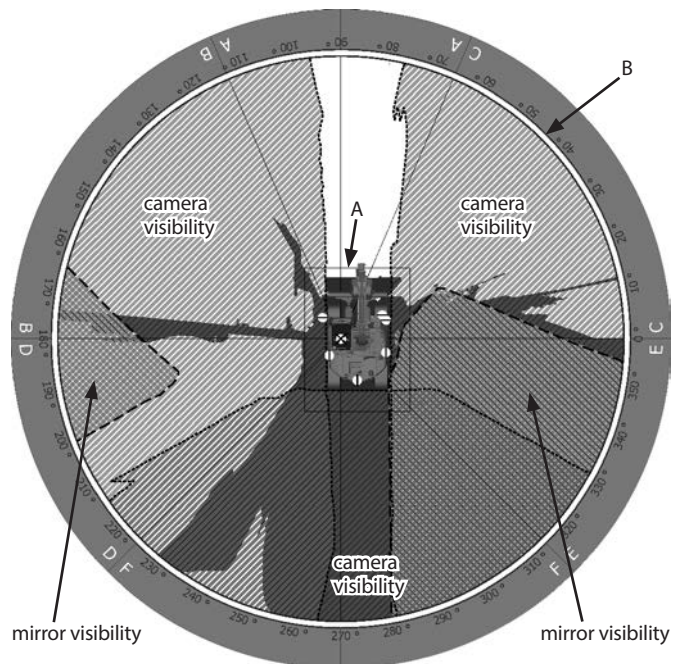

mirror visibility

Visibility Map

Image behind, image on right, image on left of machine

MDAT-VM-038

# VISIBILITY MAP

## Visibility Map for Machine Model ZX225USLC-6

### Personal Hazard

This machine complies with the essential health and safety requirements for visibility set out by Machinery Directive 2006/42/EC. This map is intended to provide information on the residual maskings (blind spots) applicable to the machine position(s) as shown, observed by a seated operator (wearing the recommended seat restraint) in the cab, using direct vision and the standard visual aids supplied with the machine. Operators are encouraged to adjust the mirrors installed on the machine to show the area as shown below.

Visibility maps provide an approximation of the residual masking to be anticipated. It can be used as a guide when conducting a site risk assessment, utilized for site management and to consider additional visual aids where needed.

### Conditions: Driver's visibility on 1 mRB and VTC are evaluated under ISO 5006.

Test Height (on 1 mRB):	1.2 m to 1.5 m
(1 mRB to VTC/on VTC):	Ground Level
Operator eye Height:	1.2 m from the cab floor
Machine Configuration:	Monoblock Boom
Machine Position:	Travel Position (For the detail position, see the image below)
Applicable visual aids:	1. Standard mirror (s) 2. Standard rear view camera 3. Standard side view camera

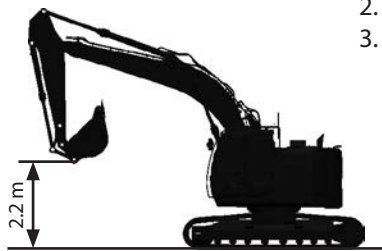

Machine Position Image

MDAT-VM-047

- ⊗ : Operator's eye point
- A : 1 m Rectangular Boundary (1mRB)
- B : 12m Visibility Test Circle (VTC)
- ⊖ : Standard Mirror(s)
- ⊕ : Standard rear view camera
- ⊙ : Standard side view camera

- : Masking area
- ▨ : Mirror visibility
- ▩ : Camera visibility
- : Masking on 1mRB / VTC

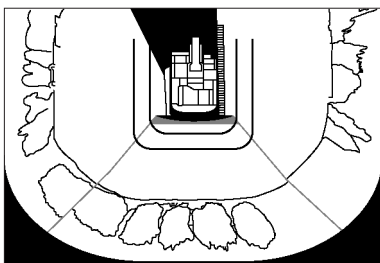

Monitor screen

MDC1-VM-039EN

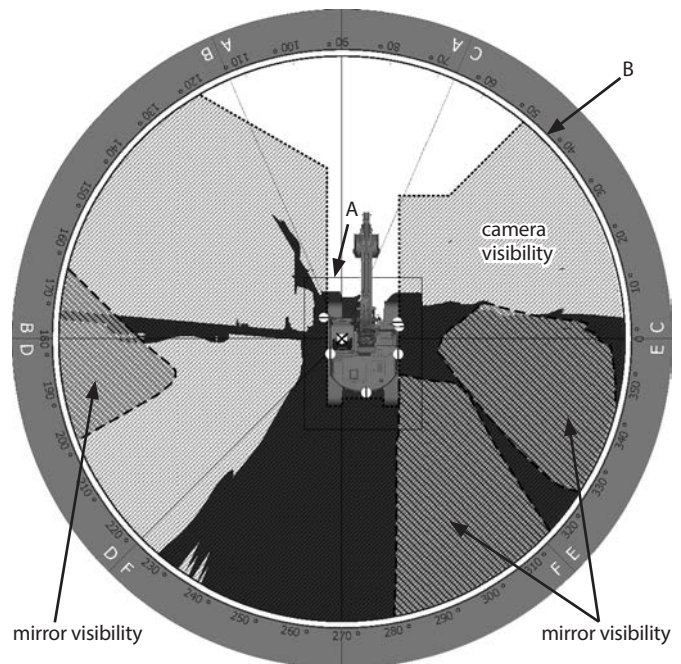

Visibility Map

MDAT-VM-085

Image around machine



# VISIBILITY MAP

- ⊗ : Operator's eye point
- A : 1m Rectangular Boundary (1mRB)
- B : 12m Visibility Test Circle (VTC)
- ⊖ : Standard Mirror(s)
- ⊙ : Standard rear view camera
- ⊙ : Standard side view camera
- : Masking area
- ▨ : Mirror visibility
- ▩ : Camera visibility
- : Masking on 1mRB / VTC

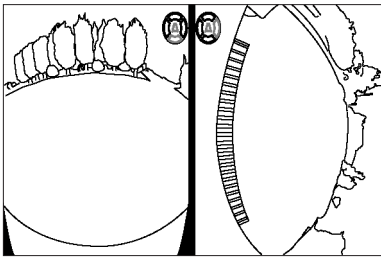

Monitor screen

MDC1-VM-040EN

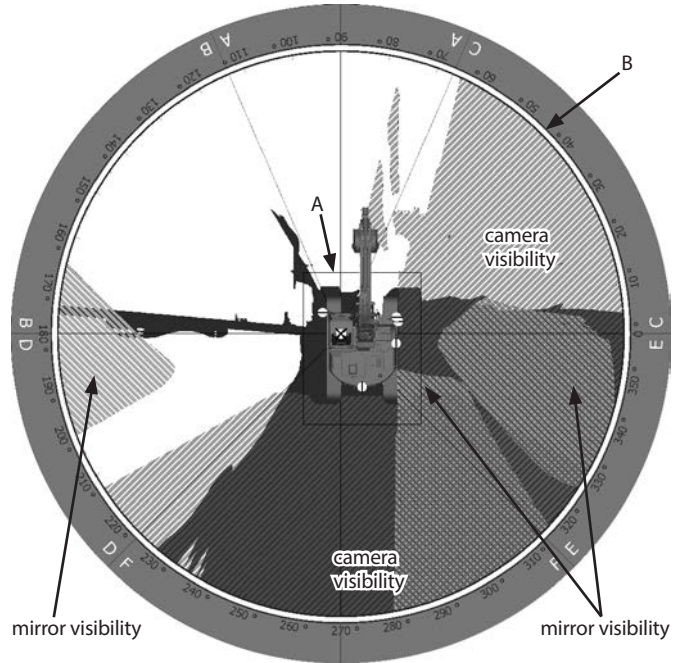

Visibility Map

MDAT-VM-086

Image behind, image on right of machine

- ⊗ : Operator's eye point
- A : 1m Rectangular Boundary (1mRB)
- B : 12m Visibility Test Circle (VTC)
- ⊖ : Standard Mirror(s)
- ⊙ : Standard rear view camera
- ⊙ : Standard side view camera
- : Masking area
- ▨ : Mirror visibility
- ▩ : Camera visibility
- : Masking on 1mRB / VTC

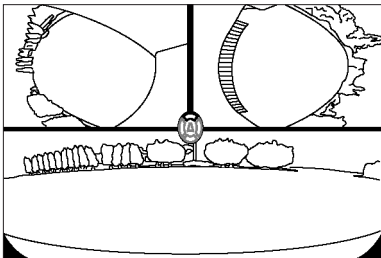

Monitor screen

MDC1-VM-041EN

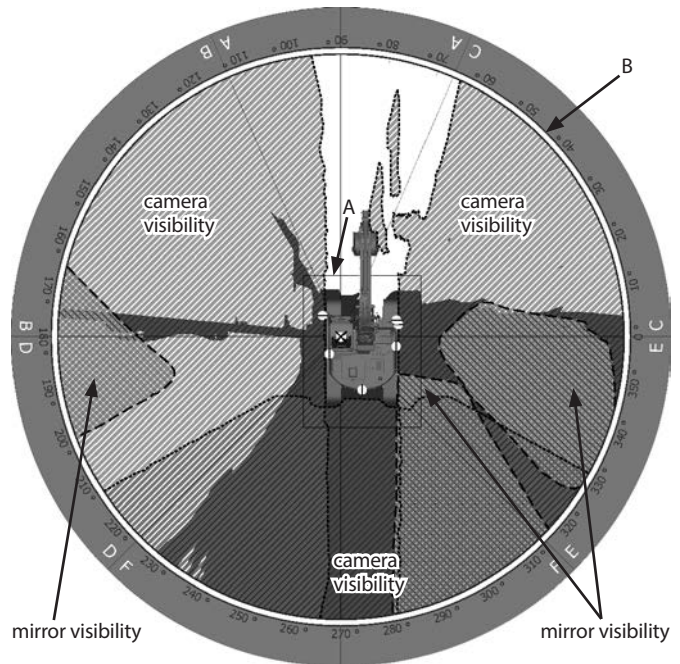

Visibility Map

MDAT-VM-087

Image behind, image on right, image on left of machine

# VISIBILITY MAP

## Visibility Map for Machine Model ZX345USLC-6

### Personal Hazard

This machine complies with the essential health and safety requirements for visibility set out by Machinery Directive 2006/42/EC. This map is intended to provide information on the residual maskings (blind spots) applicable to the machine position(s) as shown, observed by a seated operator (wearing the recommended seat restraint) in the cab, using direct vision and the standard visual aids supplied with the machine. Operators are encouraged to adjust the mirrors installed on the machine to show the area as shown below.

Visibility maps provide an approximation of the residual masking to be anticipated. It can be used as a guide when conducting a site risk assessment, utilized for site management and to consider additional visual aids where needed.

### Conditions: Driver's visibility on 1 mRB and VTC are evaluated under ISO 5006.

Test Height (on 1 mRB):	1.2 m to 1.5 m
(1 mRB to VTC/on VTC):	Ground Level
Operator eye Height:	1.2 m from the cab floor
Machine Configuration:	Monoblock Boom
Machine Position:	Travel Position (For the detail position, see the image below)
Applicable visual aids:	1. Standard mirror (s) 2. Standard rear view camera 3. Standard side view camera

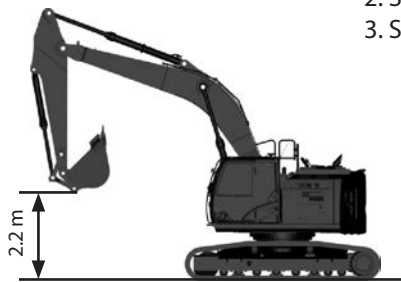

Machine Position Image

MDD5-VM-001

- ⊗ : Operator's eye point
- A : 1m Rectangular Boundary (1mRB)
- B : 12m Visibility Test Circle (VTC)
- ⊖ : Standard Mirror(s)
- ⊙ : Standard rear view camera
- ⊕ : Standard side view camera

- : Masking area
- ▨ : Mirror visibility
- ▩ : Camera visibility
- : Masking on 1mRB / VTC

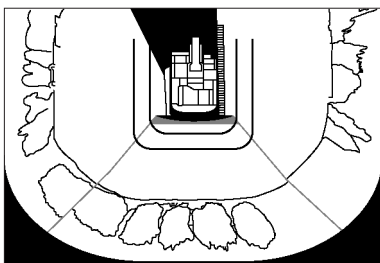

Monitor screen

MDC1-VM-039EN

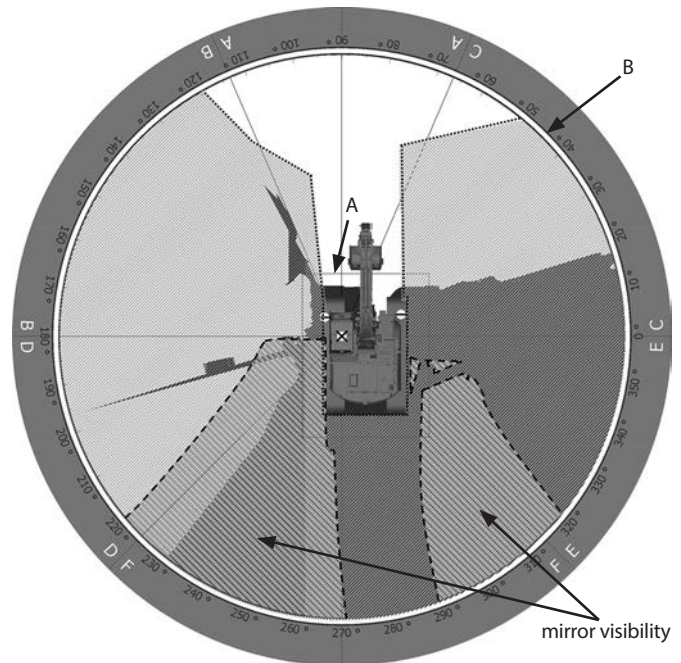

Visibility Map  
Image around machine

MDAT-VM-092

# VISIBILITY MAP

- ⊗: Operator's eye point
- A: 1m Rectangular Boundary (1mRB)
- B: 12m Visibility Test Circle (VTC)
- ⊖: Standard Mirror(s)
- ⊙: Standard rear view camera
- ⊙: Standard side view camera
- : Masking area
- ▨: Mirror visibility
- ▩: Camera visibility
- : Masking on 1mRB / VTC

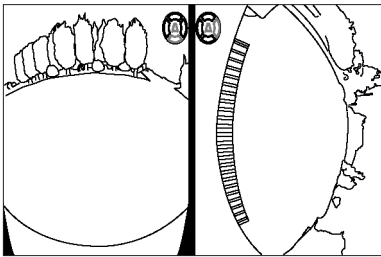

Monitor screen

MDC1-VM-040EN

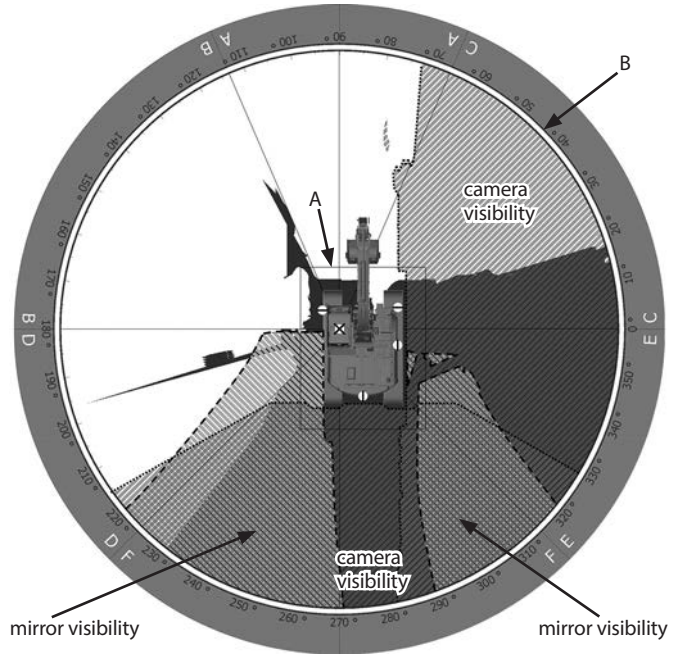

Visibility Map

MDAT-VM-093

Image behind, image on right of machine

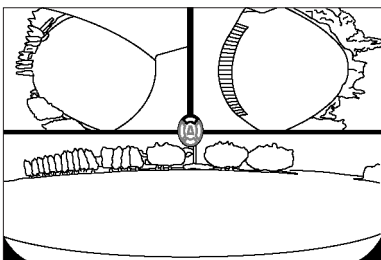

Monitor screen

MDC1-VM-041EN

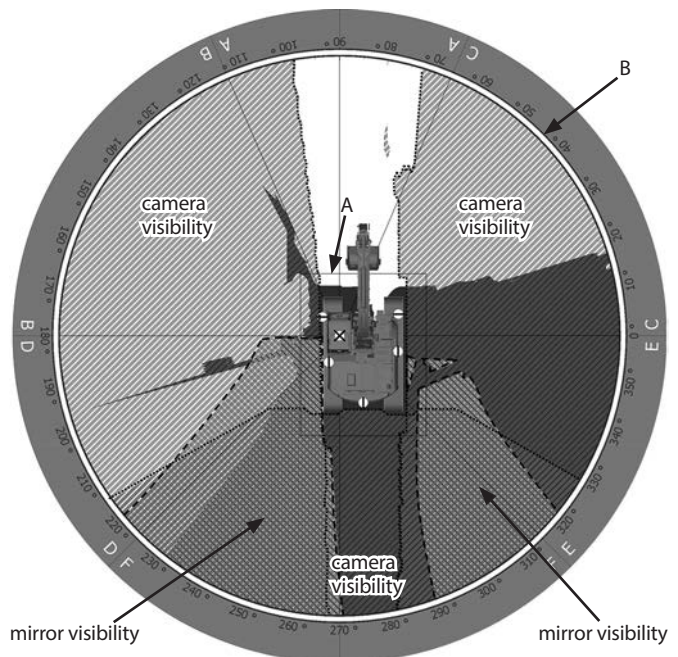

Visibility Map

MDAT-VM-094

Image behind, image on right, image on left of machine



## SAFETY SIGNS

All safety signs and their locations affixed on the machine are illustrated in this group. Make sure of the contents described in the safety signs through reading actual ones affixed on the machine to ensure safe machine operation. Always keep the safety signs clean. In case a safety sign is broken or lost, immediately, obtain a new replacement and affix it again in position on the machine. Use the part No. indicated under the right corner of each safety sign illustration when placing an order of it to the Hitachi dealer.

### ZX135US-6, 225USLC-6

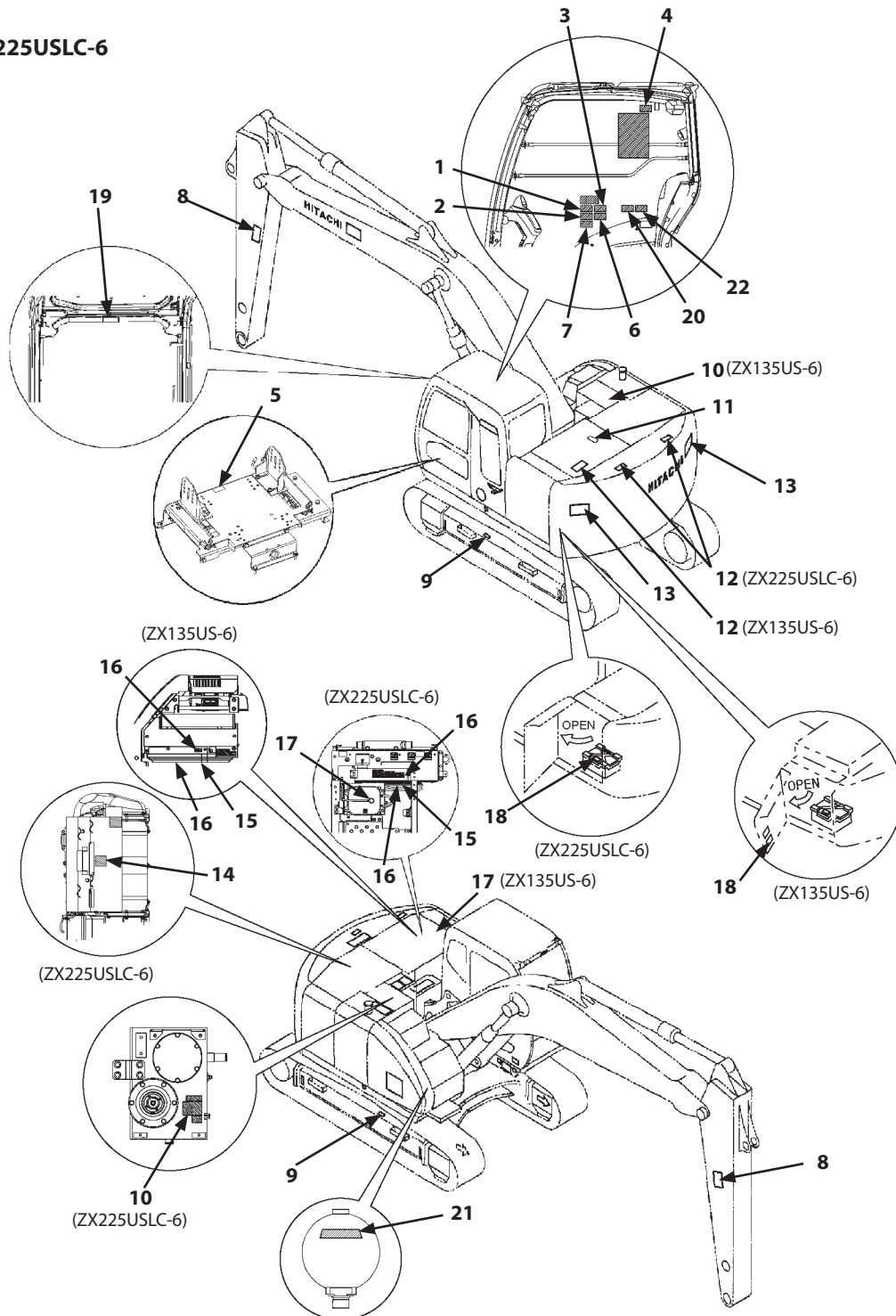

# SAFETY SIGNS

ZX345USLC-6

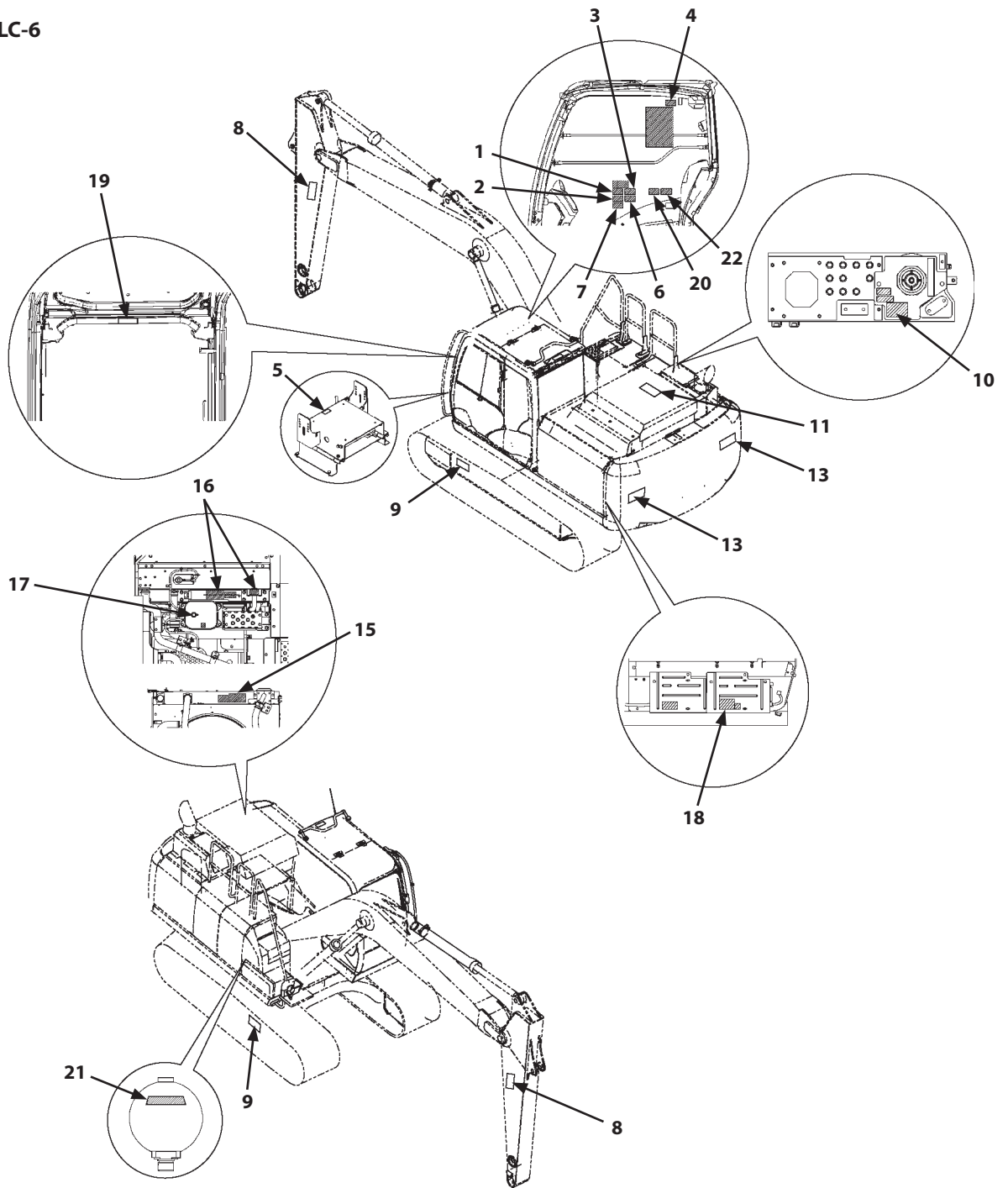

SS-4317

## SAFETY SIGNS

1.

### WARNING!

Prior to operation, maintenance, disassembling, and transportation of the machine, be sure to read and understand the Operator's Manual.

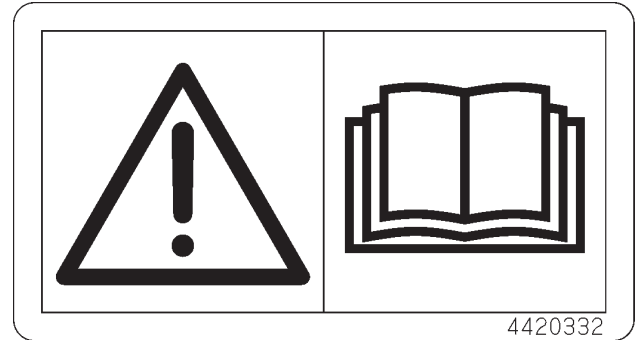

SS4420332-2

2.

If the parked machine is unexpectedly moved, serious injury or death due to crushing may result. Be sure to lower the front attachment to the ground, lock the control levers, and remove the engine key before leaving the machine unattended.

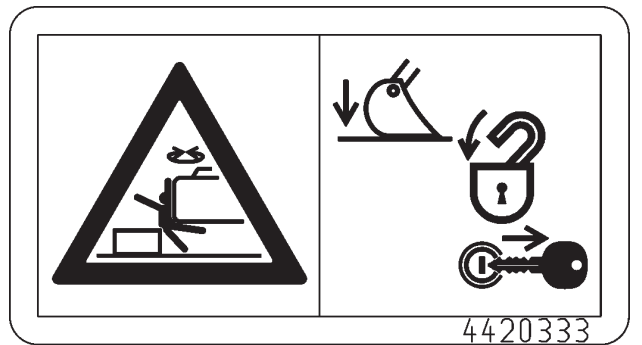

SS4420333-2

3.

Sign indicates an electrocution hazard if machine is brought too near electric power lines. Keep a safe distance from electric power lines.

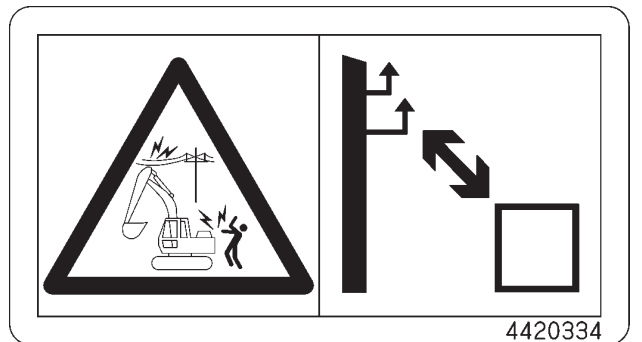

SS4420334-2

4.

Sign indicates a hazard from falling window. After raising window, be sure to lock it in place with lock pins.

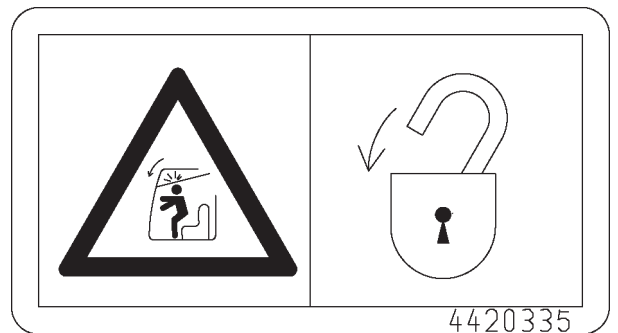

SS4420335-2

## SAFETY SIGNS

5.

When moving the seat height/tilt lever downward, press the lever grip with a palm from the top side. Do not grasp the lever grip to operate the lever, possibly resulting in pinch of your fingers into the seat stand.

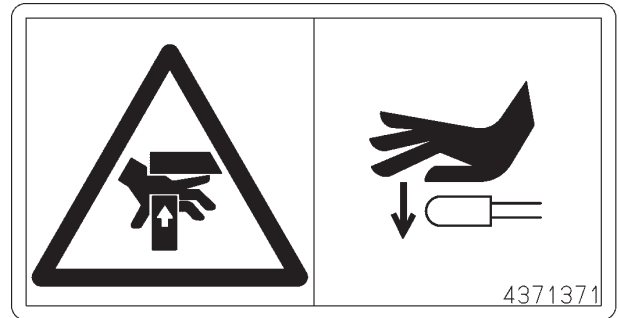

SS4371371-3

6.

If the machine should overturn, the operator may become injured and/or throw from the cab and/or crushed by the overturning machine.



SS4654287-1

7.

Do not extend your hands or head from the window. Your hands or head may come in contact with the boom. Keep away from machine during operation.

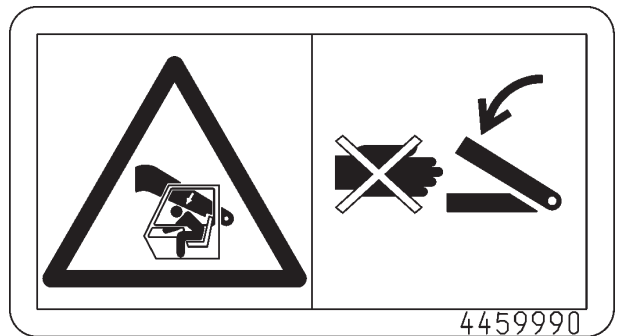

SS4459990-2

8.

Sign indicates a hazard of being hit by the working device of the machine. Keep away from machine during operation.



SS3089581-1

## SAFETY SIGNS

9.

Sign indicates a hazard of a flying plug from track adjuster that could cause injury.  
Read manual before adjusting track for safe and proper handling.

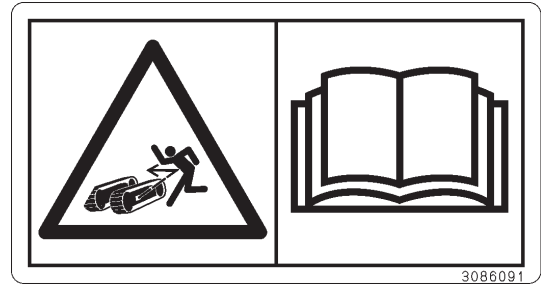

SS3086091-4

10.

Sign indicates a burn hazard from compressed air and spurting hot oil if the oil inlet is uncapped during or right after operation.  
Read manual for safe and proper handling.

A

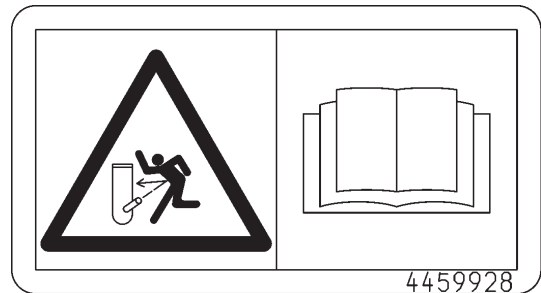

SS4459928-1

Sign indicates a burn hazard from spurting hot water or oil if radiator or hydraulic oil tank is uncapped while hot.  
Allow radiator or hydraulic oil tank to cool before removing cap.

B

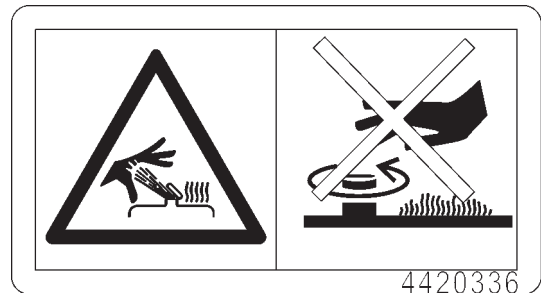

SS4420336-3

11.

Sign indicates a hazard of falling.  
Do not stand on this place.



SS3092126-2



## SAFETY SIGNS

12.

Sign indicates a hazard of falling off the fender or hood.  
Never stand close to the edge.



SS3092125-2

13.

Sign indicates a crush hazard by rotation of upper structure of the machine.  
Keep away from swinging area of machine.

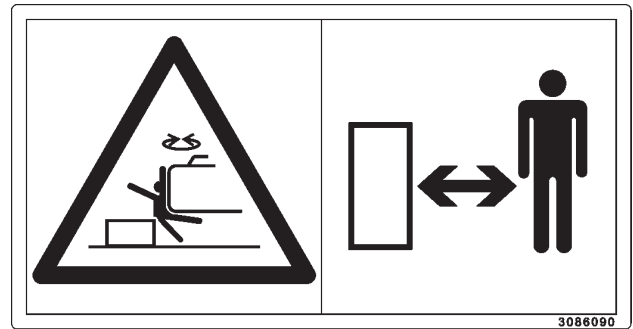

SS3086090-2

14.

Be careful to avoid skin contact with high temperature part during operation or immediately after stopping the machine. Otherwise burns may result.



SSYA00036144-2

## SAFETY SIGNS

15.

Sign indicates a hazard of rotating parts, such as belt.  
Turn off before inspection and maintenance.

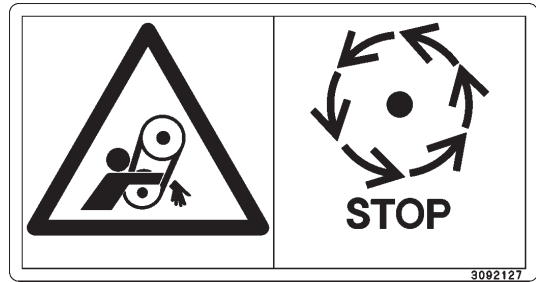

SS3092127-1

16.

Sign indicates a hazard of rotating parts, such as fan.  
Turn off before inspection and maintenance.



SSYA00008776-2

17.

Sign indicates a burn hazard from spurting hot water or oil if radiator or hydraulic oil tank is uncapped while hot.  
Allow radiator or hydraulic oil tank to cool before removing cap.



SSYA00036802-2

## SAFETY SIGNS

**18.**

Sign indicates an electrical hazard from handling the cable.  
Read manual for safe and proper handling.

A

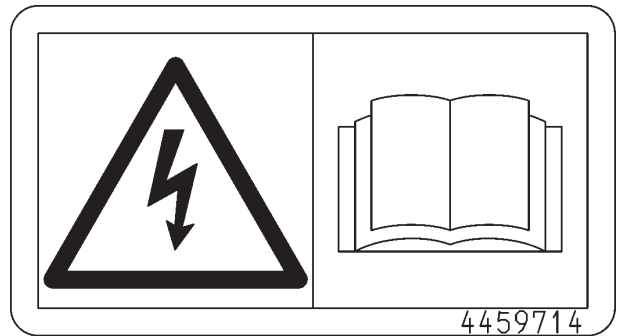

SS4459714-1

Sign indicates an explosion hazard.  
Keep fire and open flames away from this area.

B



SS4460067-2

Skin contact with electrolyte will cause burns. Splashed electrolyte into eyes will cause blindness. Take care not to touch electrolyte.

C



SS4460056-2

**19.**

Use the handle only to open or close the front window. Do not use the handle to enter or leave the cab. If the window is not locked, it may move possibly causing you to lose your balance and fall.

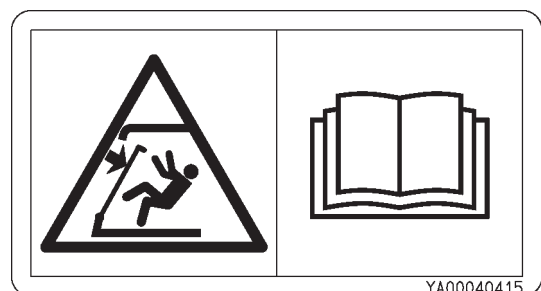

SSYA00040415

## SAFETY SIGNS

### 20.

To those persons fixed with any medical device. Including implantable device such as a cardiac pacemaker. Please read the instruction manual carefully and follow the instructions before using this machine.

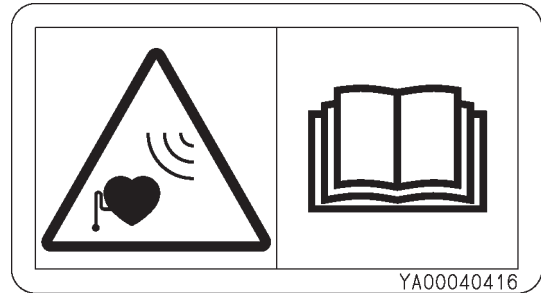

SSYA00040416

### 21.

#### WARNING

IT CONTAINS NITROGEN UNDER HIGH PRESSURE.

DON'T ALLOW FIRE OR HEAT NEAR IT. DON'T TRY TO DISASSEMBLE IT.

WEAR EYE PROTECTION AND CAREFULLY DRILL A HOLE AT THE POINT MARKED × TO RELEASE GAS PRESSURE BEFORE DISPOSAL.

WARNING  
IT CONTAINS NITROGEN UNDER HIGH PRESSURE.  
DON'T ALLOW FIRE OR HEAT NEAR IT. DON'T TRY TO DISASSEMBLE IT.  
WEAR EYE PROTECTION AND CAREFULLY DRILL A HOLE AT THE POINT MARKED × TO RELEASE GAS PRESSURE BEFORE DISPOSAL.

SS-3212

### 22.

Communication terminal can cause accidental bombing at the blasting site. Keep the machine apart from the blasting site and an electric detonator to maintain a safe distance.

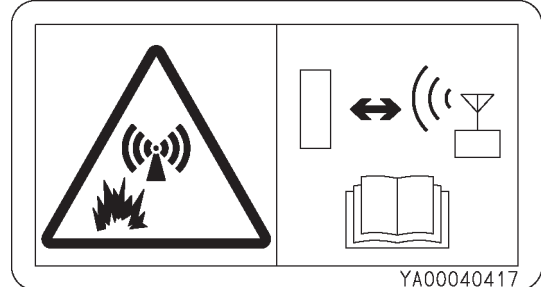

SSYA00040417



## NAME OF COMPONENTS

### Name of Components

- 1- Bucket
- 2- Bucket Cylinder
- 3- Arm
- 4- Arm Cylinder
- 5- Boom Cylinder
- 6- Boom
- 7- Fuel Tank
- 8- Hydraulic Oil Tank
- 9- Aftertreatment Device
- 10- Engine
- 11- Expansion Tank
- 12- Counterweight
- 13- Battery Disconnect Switch
- 14- DEF/AdBlue® Tank
- 15- Travel Device
- 16- Track
- 17- Front Idler
- 18- Cab

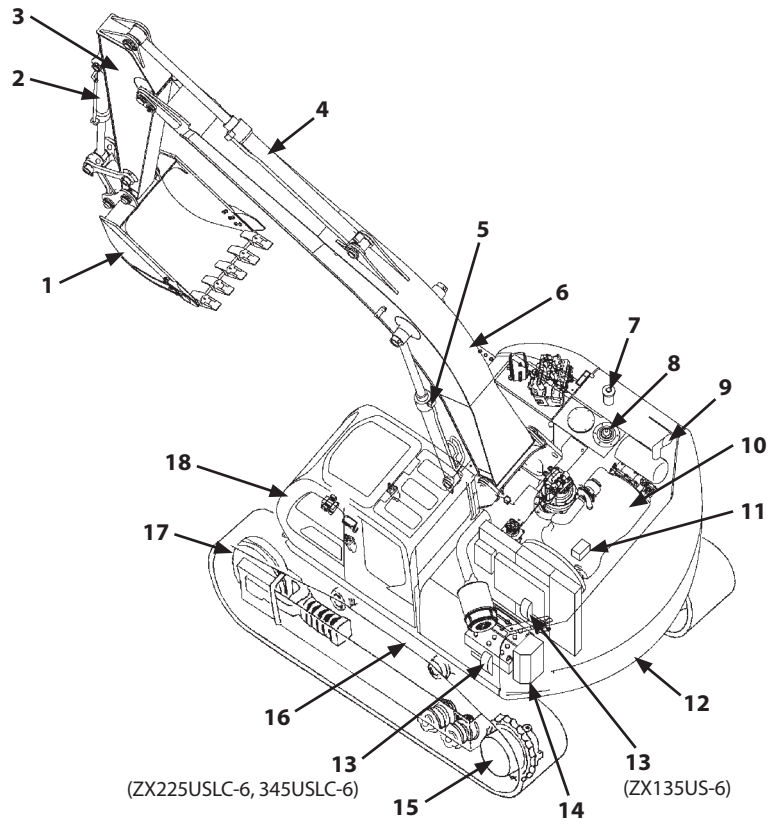

**NOTE:** A typical model is shown in the right. Some parts may differ depending on the model of the machine.

MDAT-01-001

## GETTING ON AND OFF THE MACHINE

### Getting ON and OFF the Machine

Footholds (1) and handrails (2) are provided around the machine for safe entry and exit to the cab. They also allow for safe inspection and maintenance. Never jump on or off the machine, it is very dangerous.

#### WARNING:

- When lifting the cab/main body or transporting the machine, never attach wire to footholds (1)
- Door handle (3) is not a handrail. Do not use door handle (3) as a handrail when getting on and off the machine.
- Do not hold control levers (4) or pilot control shut-off lever (5) when getting on and off the machine.

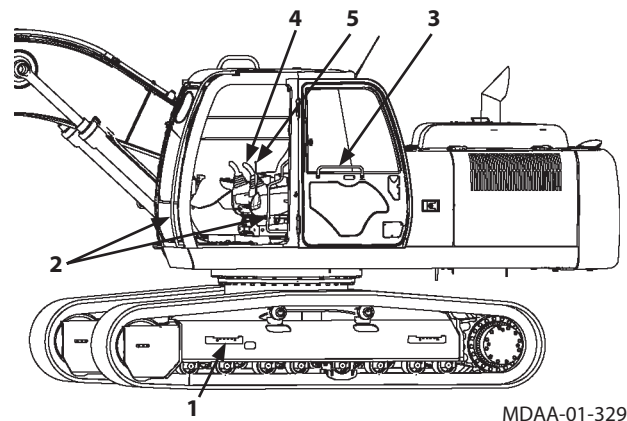

MDAA-01-329

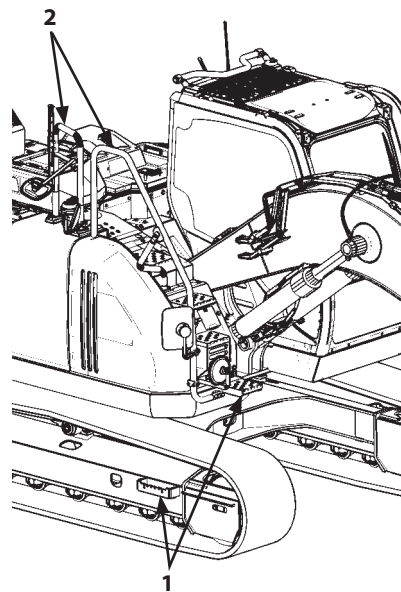

ZX135US-6

MDAT-01-243

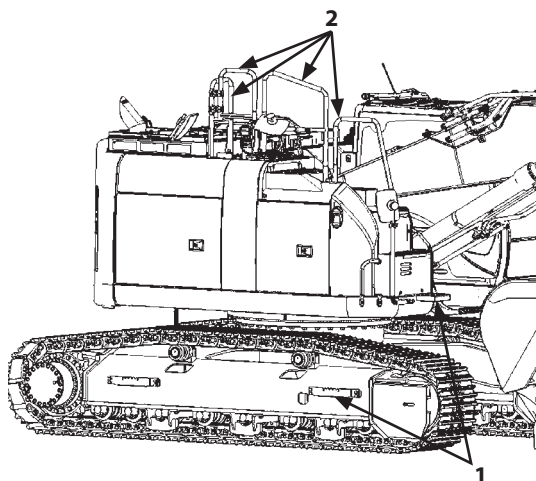

ZX345USLC-6

MDAT-01-274

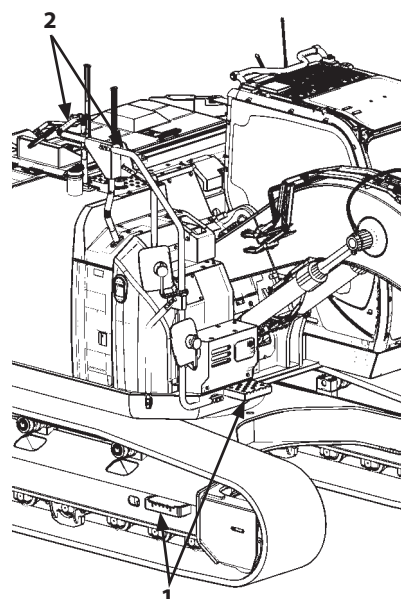

ZX225USLC-6

MDAT-01-244

## OPERATOR'S STATION

---

### About Aftertreatment Device

The aftertreatment device removes particulate matter (PM) and nitrogen oxide (NOx) from the exhaust gas. Follow the instructions below to prevent the aftertreatment from being damaged.

#### WARNING:

- **Exhaust gas from the aftertreatment device, muffler, exhaust piping and tail piping becomes hot during and just after engine running and regeneration of aftertreatment device. Pay attention not to let your skin contact any part of exhaust system or hot gas from the exhaust piping, as it may cause severe burns.**
- **If flammable materials such as dead leaves or paper scraps are around the aftertreatment device, they may cause a fire.**
- **To avoid burns, stop the engine and make sure the engine has sufficiently cooled down before performing maintenance.**

#### IMPORTANT:

- **Be sure to use fuel that complies with JIS K-2204, EN-590 or ASTM D-975 that contains 15 ppm or lower sulfur. If the fuel described above is not used, exhaust gas that exceeds regulation values may be discharged and serious engine problems may occur.**
- **Refill DEF/AdBlue® which meets Japanese Industrial Standards (JIS) or International Organization for Standardization (ISO). If improper liquid (diesel oil, kerosene or gasoline) is refilled in the DEF/AdBlue® tank, fire or system failure may result.**
- **Use only genuine Hitachi engine oil. Using engine oil other than Hitachi genuine oil may result in malfunction of the aftertreatment device.**
- **Do not mix poor quality diesel fuel, drainage agents, fuel additives, gasoline, kerosene, alcohol, or any other type of lubricating oil with specified diesel fuel. Improper fuel usage may deteriorate performance of fuel filters, can cause problems in the lubricated parts of the injector. It can also affect the engine parts and aftertreatment device, leading to malfunction.**



## OPERATOR'S STATION

---

- **Do not modify the machine without authorization. Never attempt to modify the air inlet and exhaust parts such as the air duct, aftertreatment device and the exhaust piping. Also never attempt to disassemble the aftertreatment device. Avoid giving shocks on the aftertreatment device by striking elements with other objects or dropping the device. Failure to do so may affect the aftertreatment device, possibly damaging it or lowering its performance.**
- **White smoke may be generated during the aftertreatment device regeneration. Do not attempt to perform a manual regeneration in a poorly ventilated area.**
- **Consult your authorized dealer for checking or repairing the aftertreatment device.**

 NOTE:

- *White deposits may accumulate inside the aftertreatment device. The aftertreatment device is automatically regenerated to remove accumulated white deposits at regular intervals. It is called auto-regeneration. The auto-regeneration may start during operation of the machine; you can continue to operate the machine. (Refer to the page 1-26)*
- *Do not stop the engine during regeneration unless absolutely necessary.*
- *The auto-regeneration may be terminated depending on the machine operating condition.*
- *Usually, auto-regeneration starts 30 hours after the previous regeneration (either auto or manual).*

## OPERATOR'S STATION

---

- *If auto regeneration did not complete, and 38 hours have passed since the previous regeneration, an aftertreatment device regeneration request will blink on the monitor. (Refer to the page 1-27) Perform manual regeneration following the specified procedure. (Refer to the page 1-28)*
- *When the machine is operated without performing manual regeneration, the aftertreatment device may be damaged. Immediately move the machine to a safe area and perform manual regeneration.*
- *If approximately 48 hours have passed without regeneration being carried out, the engine trouble alarm will be displayed on the monitor (Refer to the page 1-27). Consult your authorized Hitachi dealer.*
- *Both auto and manual regenerations restore aftertreatment device function. It is not a malfunction.*
- *White smoke may be emitted for several minutes after the engine starts, this is not a malfunction.*

## OPERATOR'S STATION

### Cab Features

#### ZX135US-6, 225US-6 class

- 1- Left Control Lever/Horn Switch
- 2- Left Travel Pedal
- 3- Left Travel Lever
- 4- Right Travel Lever
- 5- Right Travel Pedal
- 6- Right Control Lever/Power Boost Switch
- 7- Multi Function Monitor Panel
- 8- Switch Panel
- 9- Key Switch
- 10- Regeneration Switch
- 11- Operator's Seat
- 12- Cab Door Release Lever
- 13- Pilot Control Shut-Off Lever
- 14- Fuse Box
- 15- Cigar Lighter
- 16- Switch Panel (for Optional Equipments)  
Glove Compartment (without Optional Equipment)
- 17- Glove Compartment (Hot and Cool Box)
- 18- Engine Stop Switch
- 19- 12 V Power Supply
- 20- USB Power Supply port
- 21- Screen Changeover Switch

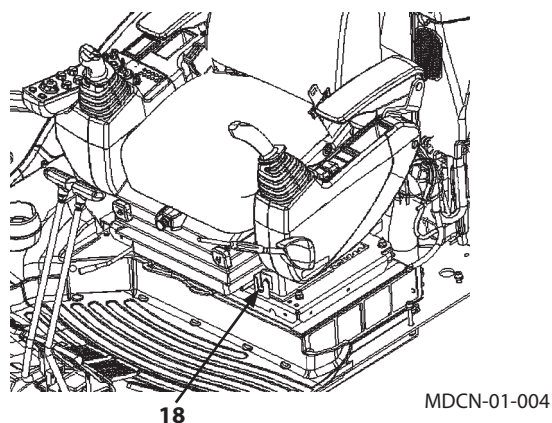
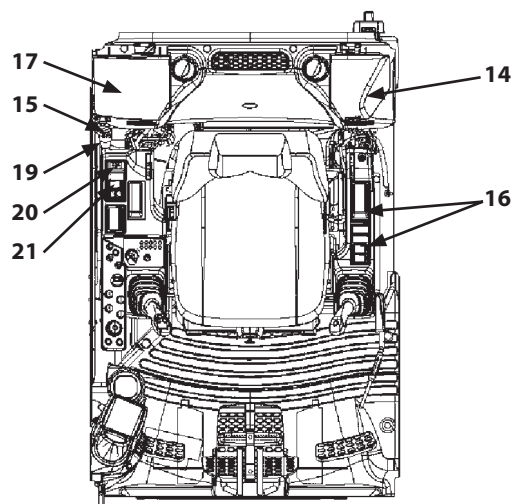
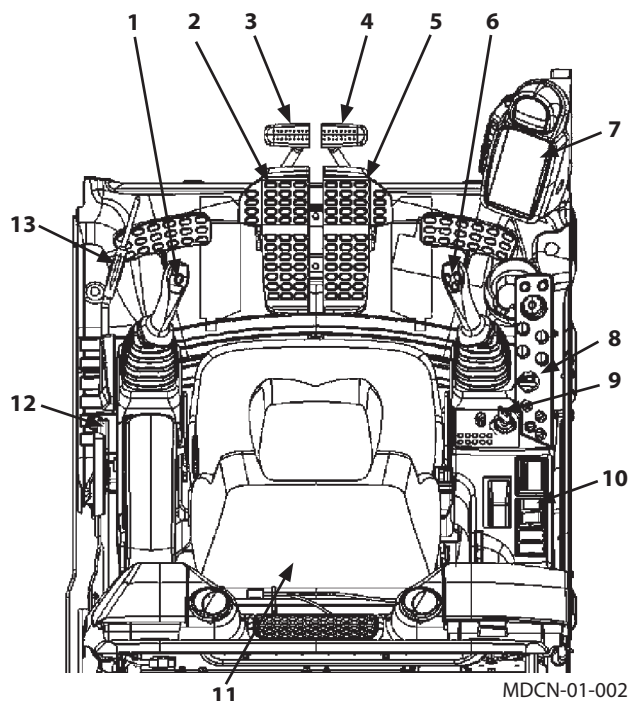

# OPERATOR'S STATION

## Cab Features

### ZX345US-6 class

- 1- Left Control Lever/Horn Switch
- 2- Left Travel Pedal
- 3- Left Travel Lever
- 4- Right Travel Lever
- 5- Right Travel Pedal
- 6- Right Control Lever/Power Boost Switch
- 7- Multi Function Monitor Panel
- 8- Switch Panel
- 9- Key Switch
- 10- Regeneration Switch
- 11- Operator's Seat
- 12- Cab Door Release Lever
- 13- Pilot Control Shut-Off Lever
- 14- Glove Compartment
- 15- Fuse Box
- 16- Cigar Lighter
- 17- Switch Panel (for Optional Equipments)  
Glove Compartment (without Optional Equipment)
- 18- Glove Compartment (Hot and Cool Box)
- 19- Engine Stop Switch
- 20- 12 V Power Supply
- 21- USB Power Supply port
- 22- Screen Changeover Switch
- 23- Auxiliary

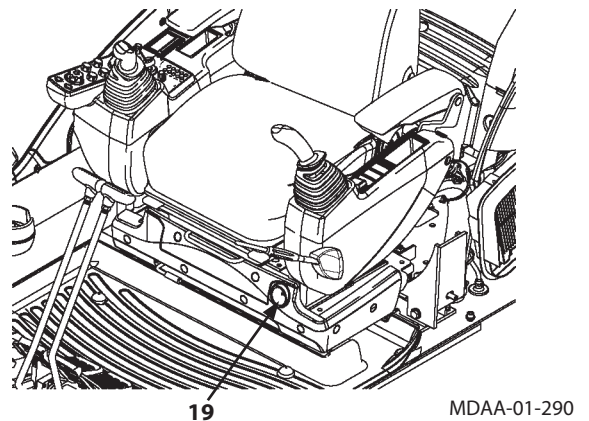
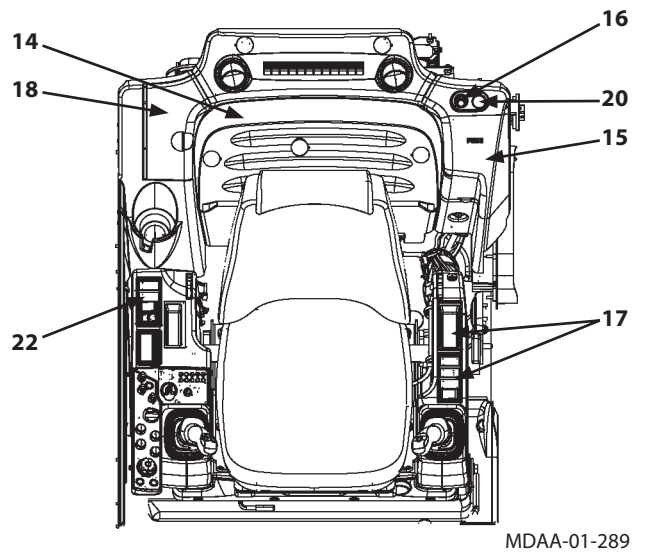
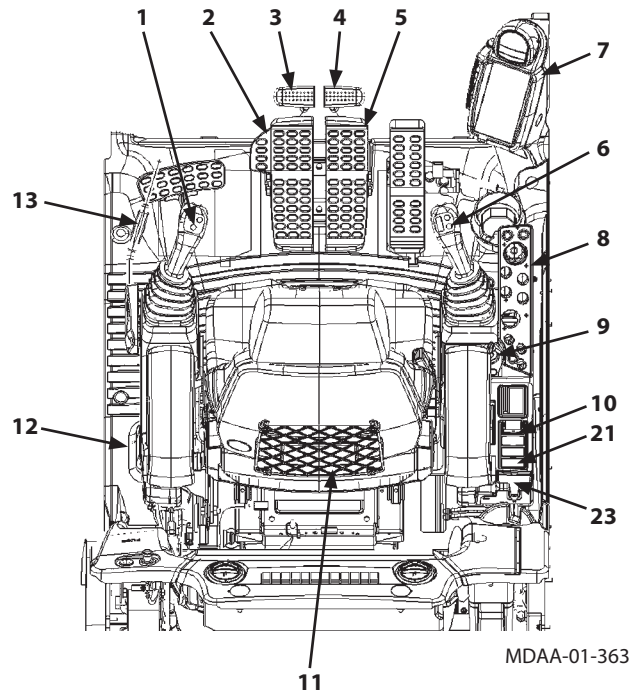

# OPERATOR'S STATION

## Multi Function Monitor

### Feature

The multi function monitor displays various meters, indicators, radio and air conditioner, numeric keypad lock function, rearview camera image, work mode selection and maintenance screen.

### Screen Configuration

The multi function monitor consists of the following screens.

There are 9 menus, and a further 16 sub menus.

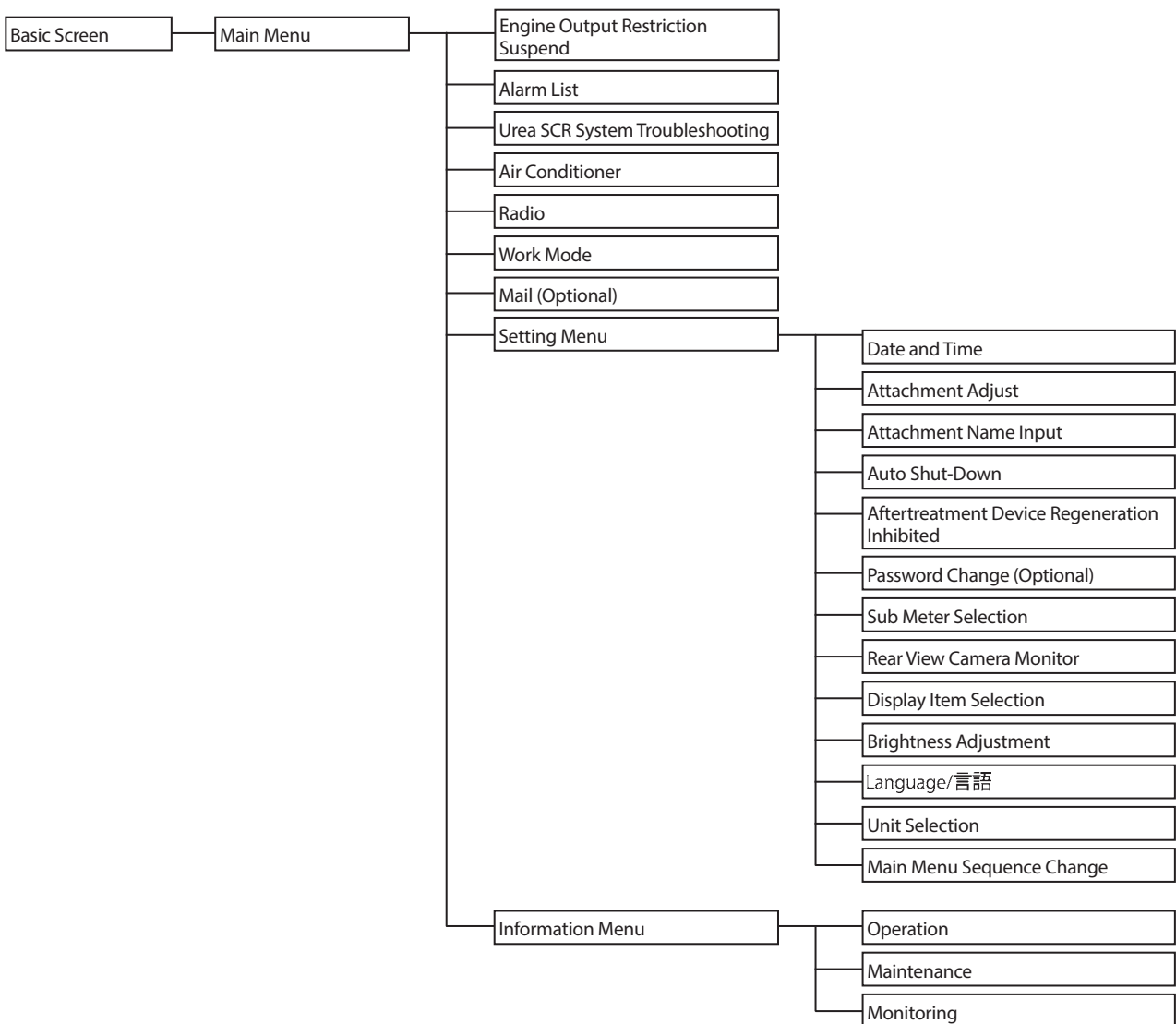

## OPERATOR'S STATION

### Default Setting

Function	Item	Default
Auto Shut-Down	ON/OFF of Auto Shut-down	OFF
	Setting Time	1 min
Aftertreatment Device Regeneration Inhibited	Regeneration Inhibited	OFF

 **NOTE:** Typical functions are shown in the table. Check the initial values of other functions on each monitor screen.

## OPERATOR'S STATION

### Basic Screen

- 1- Work Mode Display
- 2- Aftertreatment Device Display
- 3- Power Mode Display
- 4- Hour Meter, Clock
- 5- Auxiliary
- 6- Auxiliary
- 7- Preheat Display
- 8- Seat Belt Display
- 9- Fuel Gauge
- 10- Sub Meter Display
- 11- Radio Display
- 12- Air Conditioner Display
- 13- Coolant Temperature Gauge
- 14- Auxiliary
- 15- Auxiliary
- 16- Travel Mode Display
- 17- Auto Shut-Down Display
- 18- Auto-Idle Display
- 19- DEF/AdBlue® Gauge

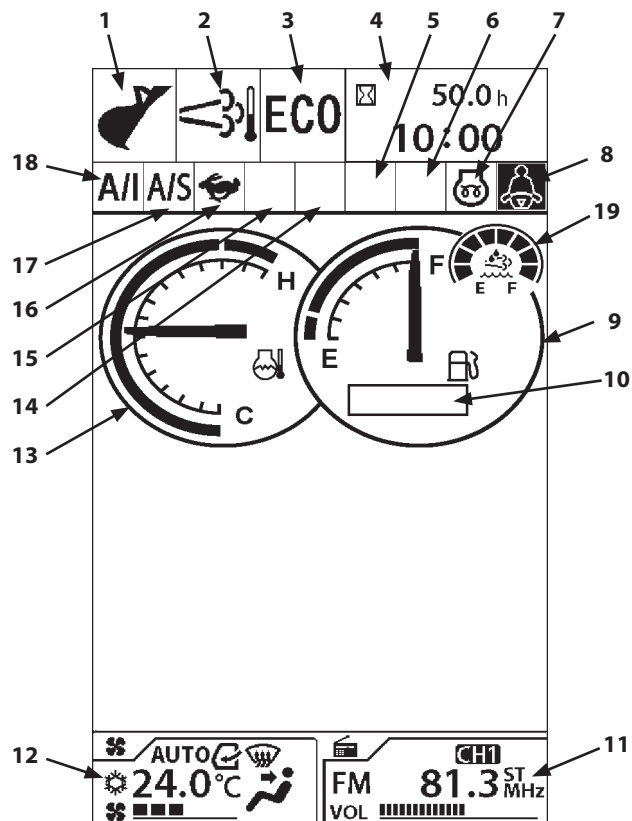

MDC1-01-020

# OPERATOR'S STATION

## How to Use Screens

### Displaying Basic Screen

**IMPORTANT:** Start the engine after the basic screen is displayed.

When the key switch is turned to the ACC or ON position, the starting screen displays for about 2 seconds. When the key switch is kept in ACC position, only hour meter, clock and radio will be displayed. When the key switch is turned from ACC to ON position, the basic screen will be displayed.



Starting Screen

MDAA-01-003EN

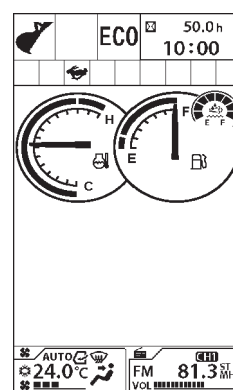

Basic Screen

MDC1-01-001

**IMPORTANT:** When the key switch is turned to ON position, the alternator alarm will be displayed on the basic screen. Until the alternator starts generating power after the engine starts, the alternator alarm is displayed on the basic screen.

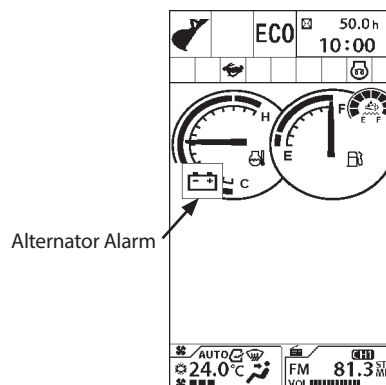

Alternator Alarm

MDC1-01-042



# OPERATOR'S STATION

- Display of Meters  
Items to be displayed  
4- Hour Meter, Clock  
9- Fuel Gauge  
13- Coolant Temperature Gauge  
19- DEF/AdBlue® Gauge
- Work Mode Display  
The attachments being used are displayed.

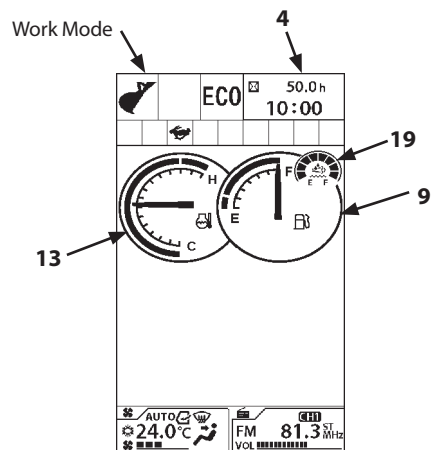

MDC1-01-001

## Digging Mode



## Attachment Mode

### Breaker



### Pulverizer



### Crusher



### Vibrating Hammer



### Grapple



### Clamshell



### Thumb



### Tilting Rotator

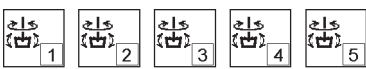

### Tilting Bucket

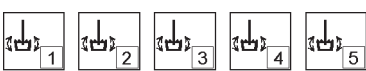

### Others

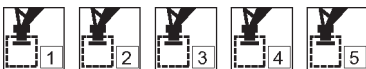

## OPERATOR'S STATION

- Aftertreatment Device Display (2)  
Displays condition of the aftertreatment device.
- Power Mode Display (3)  
Displays the power mode selected from the switch panel.
- Preheat Display (7)  
While the current is being supplied to the glow plug, indicator (7) is displayed.
- Seat Belt Display (8)  
Turns ON when the key switch is in the ON position, and turns OFF 5 seconds after the engine starts.

Lights when the key is ON and goes off when the seat belt is fastened.

If the engine is operated without fastening the seat belt and the pilot control shut-off lever is lowered, the indicator starts flashing and the buzzer sounds after 5 seconds.

After 30 seconds the buzzer changes from a long to a short intermittent buzzing.

Fastening the seat belt makes the indicator go off and the buzzer stop.

- Sub Meter Display (10)  
Fuel consumption or breaker hour meter is displayed.
- Radio Display (11)  
Displays the radio panel.
- Air Conditioner Display (12)  
Displays the air conditioner panel.
- Travel Mode Display (16)  
Displays the travel mode selected from the switch panel.
- Auto Shut-Down Display (17)  
Display auto shut-down display (17) when auto shut-down is turned ON from the menu screen.  
When the key switch is turned ON while auto shut-down is enabled, auto shut-down display (17) blinks for 10 seconds.

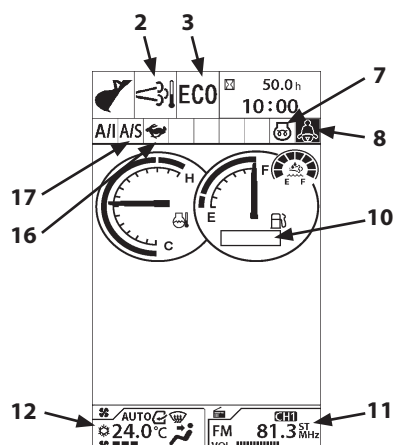

MDC1-01-020

## OPERATOR'S STATION

- **Auto-Idle Display (18)**

When the auto-idle is selected from the switch panel, auto-idle display (18) displays.

When the key switch is turned ON while the auto-idle switch is also ON, auto-idle display (18) blinks for 10 seconds.

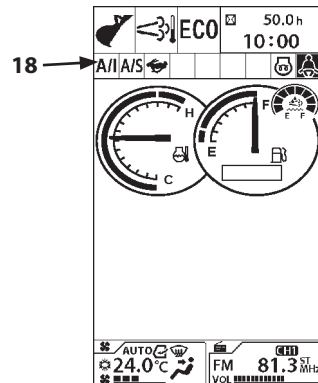

MDC1-01-286

### Hour Meter

The total accumulated operating hours since the machine started working, are displayed in hours (h). One digit after the decimal point indicates tenths of an hour (6 minutes).

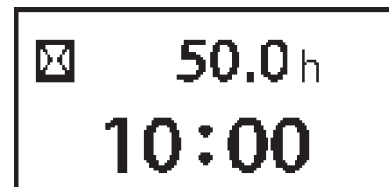

MDAA-01-021EN

### Clock

Indicates the current time.

24-h/12-h display can be selected.

(Refer to "Date and Time" for switching the display mode.)

### Fuel Gauge

The remaining fuel amount is indicated by the needle. Refuel before the needle reaches "E".

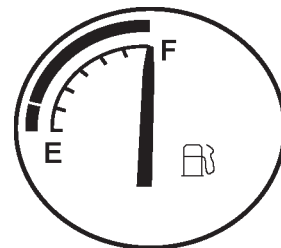

MDAA-01-276

## OPERATOR'S STATION

### DEF/AdBlue® Gauge

The remaining DEF/AdBlue® amount is indicated on the segment display.



When DEF/AdBlue® level becomes low, the last segment turns yellow. If the segment display turns yellow, immediately refill DEF/AdBlue®.



**IMPORTANT: Display of the DEF/AdBlue® gauge changes depending on the DEF/AdBlue® level. If the engine runs with a low level of DEF/AdBlue®, the engine power will gradually be reduced. If the gauge turns yellow, immediately refill DEF/AdBlue®.**

MDC1-01-509

### DEF/AdBlue® Level Alarm

Screen Display	Display of Segments	Buzzer	Content of Alarm
	The last segment turns yellow.	Once	DEF/AdBlue® level is low. Refill DEF/AdBlue® as soon as possible.
	The last segment turns red.	Intermittent sound	DEF/AdBlue® level is low. The engine output power derates gradually. Refill DEF/AdBlue® as soon as possible.
	All segments turn OFF.	Continuous sound	No DEF/AdBlue®. The engine can start, but the machine can not be operated. The machine can not be operated until refilling DEF/AdBlue®.

## OPERATOR'S STATION

### Coolant Temperature Gauge

The engine coolant temperature is indicated with a needle. Normally the needle is around the center of the scale during operation.

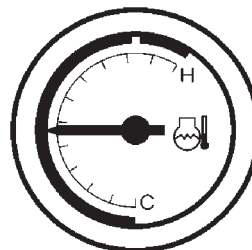

M1U1-01-047

### Operating Status Icon Display

Displays icons indicating the current status of each of following items: Attachment (1) and aftertreatment device display (2) selected from the work mode selection screen; power mode (3), preheat indicator (4), travel mode (5), auto shut-down (6) ON, auto-idle (7) ON selected from the switch panel.

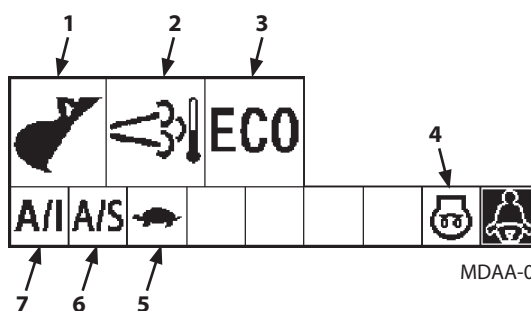

MDAA-01-023

## OPERATOR'S STATION

### Security Functions (Optional)

#### Input Password

#### IMPORTANT:

- When required to activate the numeric keypad function, consult your authorized dealer.
- If the password is forgotten, the machine must be modified. Be extremely careful not to forget the password.

1. Turn the key switch ON. After the starting screen is displayed, the password input screen will be displayed.
2. Input a password by using the numeric keypad.
3. The monitor unit matches the input password to the registered one. If they match, the basic screen displays. The engine is ready to run. If an incorrect password is input 3 times, a buzzer sounds for 30 seconds. During that time, the buzzer does not stop even if the key switch is turned ON/OFF.

 **NOTE:** If you make a mistake while entering the password, push the CLEAR key in order to erase the entered characters.

4. After 30 seconds, if the key switch is turned to the ON position, the starting screen displays and the password input screen displays again. Then the password can be input again.
5. If an incorrect password is input again, the buzzer sounds for a further 30 seconds.



Starting Screen

MDAA-01-003EN

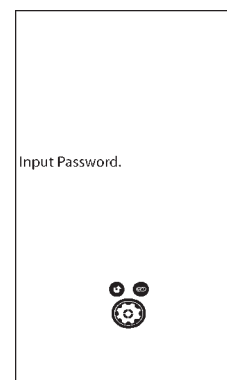

Password Input Screen

MDAA-01-085EN

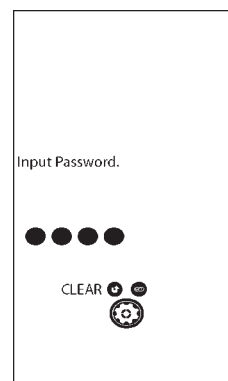

MDAA-01-086EN

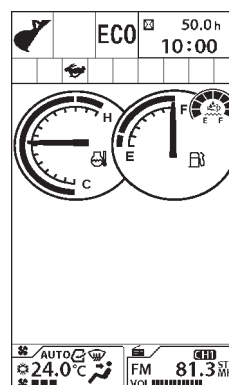

Basic Screen

MDC1-01-001

## OPERATOR'S STATION

### Extending Password Duration Time

**IMPORTANT:** This operation is applicable only to machines that require a password.

By using the password duration screen, password duration time can be set. When restarting the machine, a password need not be input within the specified timeframe.

1. When turning the key switch from ON to ACC position, the monitor unit displays the password duration screen for 10 seconds.

2. While the password duration screen is still displayed, rotate selector knob (1) to highlight the relevant time. Pushing selector knob (1) sets the password duration time.

- Duration time    0 minute
- Duration time    30 minute
- Duration time    60 minute
- Duration time    90 minute
- Duration time    120 minute

 **NOTE:** If the password duration time is not set explicitly, a duration of 0 is assumed.

3. If turning the key switch to the ON position within the password duration time, the monitor unit displays the basic screen after the starting screen.

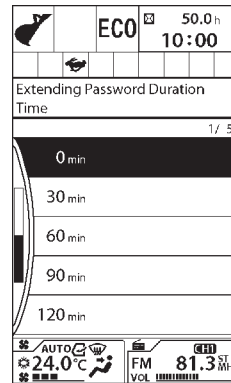

MDAA-01-087EN

Password Duration Screen (Key Switch: OFF)

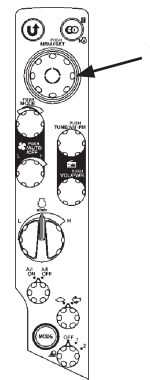

MDCD-01-026



Starting Screen

MDAA-01-003EN

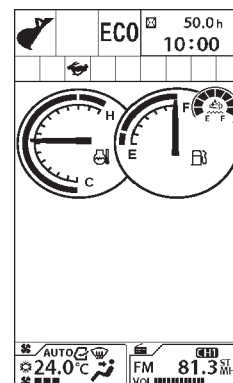

MDC1-01-001

# OPERATOR'S STATION

## Alarm Occurrence Screen

In case any abnormality occurs, alarm marks (1) are displayed on the basic screen.  
If six or more alarms are generated, alarm marks (1) can be scrolled by rotating switch (2).

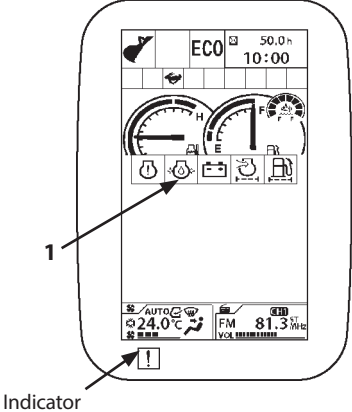

MDC1-01-316

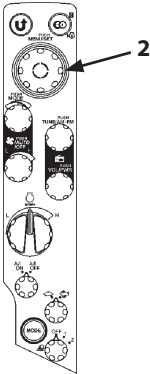

MDCD-01-026



# OPERATOR'S STATION

Follow the procedure below to display detailed information for an alarm.

Push selector knob (1) on basic screen (2) to display main menu (3).

Rotate selector knob (1) to select alarm list (4), and push selector knob (1).

Rotate selector knob (1) to select a required alarm from alarm list (5), and push selector knob (1).

Detailed information of the selected alarm will be displayed.

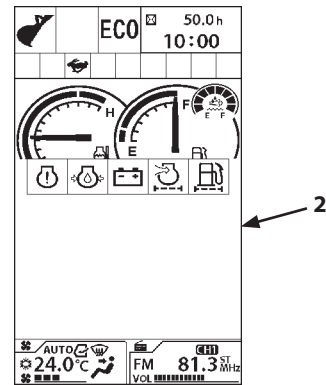

MDC1-01-004

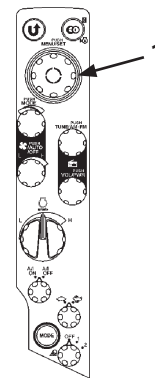

MDCD-01-026

**NOTE:**

- Main menu (3) displays alarm list (4) only when an alarm occurs.

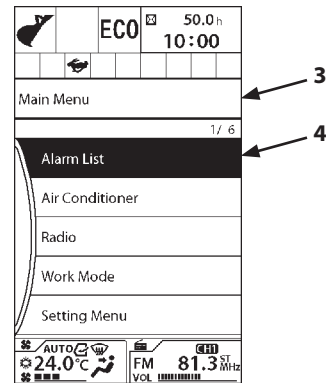

MDAA-01-077EN

- Alarm list (5) contains only currently generated alarms.

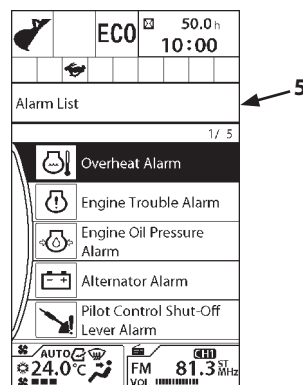



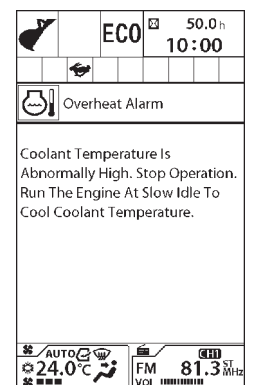



MDCD-01-006EN

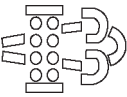
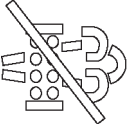
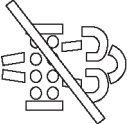

MDCD-01-007EN

## OPERATOR'S STATION









### Remedy

Display	Alarm Name	Content of Alarm
	DEF/AdBlue® Alarm*	DEF/AdBlue® Level Is Low Or Urea SCR System Is Abnormal. Refill DEF/AdBlue® If Level Is Low. Consult Your Authorized Hitachi Dealer For System Malfunction.
	Engine Output Restriction	Engine Output Is Restricted.
	Aftertreatment Device Regeneration Request (Blinking) (Yellow)	Aftertreatment Device Regeneration Is Needed. Set Pilot Control Shut-off Lever To The LOCK Position. Run The Engine At Slow Idle Speed. Turn The Manual Regeneration Switch To The Regeneration Position.
	Aftertreatment Device Regeneration Inhibited Alarm (Lighting) (Yellow)	As The Regeneration Inhibition Has Been Set, Manual Regeneration Cannot Be Performed. Move The Machine To A Safe Area, Release The Regeneration Inhibition, And Perform Manual Regeneration.
	Aftertreatment Device Auto-Regeneration Inhibited Alarm (Lighting) (Yellow)	As The Regeneration Inhibition Has Been Set, Auto Regeneration Cannot Be Performed. Move The Machine To A Safe Area And Release The Regeneration Inhibition.
	Engine Oil Level Alarm	Check Engine Oil Level And Add Oil If Required.
	Coolant Level Alarm	Check Coolant Level And Add Coolant If Required.
	Overheat Alarm**	Coolant Temperature Is Abnormally High. Stop Operation. Run The Engine At Slow Idle To Cool Coolant Temperature.

 NOTE: \*Alarm mark is displayed and buzzer will sound.











\*\*Alarm mark is displayed and buzzer will sound. Turn engine control dial to the slow idle position, and buzzer will stop.

## OPERATOR'S STATION

Display	Alarm Name	Content of Alarm
	Engine Trouble Alarm	Engine Or Accessory Are Abnormal. Contact Your Nearest Authorized Dealer.
	Engine Oil Pressure Alarm*	Engine Oil Pressure Is Low. Immediately Stop Engine. Check Engine Oil System And Oil Level.
	Engine Start Disabled	Engine Cannot Start If Pilot Shut-Off Lever Is In The UNLOCK Position.
	Engine Start Disabled	Engine Cannot Start If Engine Shut-Off Switch Is In The OFF Position.
	Boost Temperature Alarm	Engine Intake Air Temperature Is Abnormally High. Stop Operation And Check For Clogged Intercooler And/Or Disconnected Intake Airline.
	Exhaust Temperature Alarm	Exhaust Temperature Is Abnormally High. Stop Operation. Check The Exhaust Piping.
	Aftertreatment Device Regeneration System Abnormal	Aftertreatment Device Regeneration System Is Abnormal. Consult Your Authorized Hitachi Dealer.
	Alternator Alarm	Electrical System Is Abnormal. Check Alternator And Battery Systems.
	Fuel Level Alarm	Fuel Level Is Low.

 **NOTE:** \*Alarm mark is displayed and buzzer will sound.

## OPERATOR'S STATION











Display	Alarm Name	Content of Alarm
	Fuel Temperature Alarm	Fuel Temperature Is Abnormally High. Stop Operation And Check For Any Abnormality Such As Clogged Fuel Cooler.
	Hydraulic Oil Filter Restriction Alarm (Optional)	Hydraulic Oil Filter Is Clogged. Replace Hydraulic Oil Filter Element.
	Air Cleaner Restriction Alarm	Air Cleaner Is Clogged. Clean Or Replace Air Cleaner Element.
	Water Separator Alarm	Water Separator Is Full. Drain Water.
	Fuel Filter Restriction Alarm*	Fuel filter is clogged. Replace fuel filter element.
	System Failure Alarm	Machine Network System Is Abnormal. Contact Your Nearest Authorized Dealer.
	Electric Lever Alarm	Electric Lever System Is Abnormal. Contact Your Nearest Authorized Dealer.
	Control Lever Auto-Locking System Failure Alarm (Flashing)	This indicates the control lever auto-locking system is not operating. If it is cold outside, thoroughly heat up the vehicle. If it continues to flash after warmup, there is a problem with the control lever auto-locking system. Consult your authorized dealer.
	Control Lever Auto-Locking System Active (Lit)	The pilot control shut-off lever may have been moved to the UNLOCK position when a control lever was engaged. Return the pilot control shut-off lever to its LOCK position, make sure control levers are in neutral and then put the pilot control shut-off lever in its UNLOCK position.
	Pilot Control Shut-Off Lever Alarm	Pilot Control Shut-Off Lever System Is Abnormal. Contact Your Nearest Authorized Dealer.

 **NOTE:**

- The hydraulic oil filter alarm lights only when the high performance element (optional) is used.
- \*If the indicator comes ON immediately after replacing the fuel filter, air mixed in the system during replacement may be the cause. Be sure to bleed air from the fuel system when replacing the fuel filter. (When air is bled, the indicator will go OFF.)

## OPERATOR'S STATION

### Urea SCR System Remedy

Display	Alarm Name	Content of Alarm
 <div style="border: 1px solid black; padding: 2px; display: inline-block;">           REFILL DEF/AdBlue         </div>	DEF/AdBlue <sup>®</sup> Level Alarm*	DEF/AdBlue <sup>®</sup> Level Is Low. Refill DEF/AdBlue <sup>®</sup> .
 <div style="border: 1px solid black; padding: 2px; display: inline-block;">           REFILL DEF/AdBlue         </div> 	DEF/AdBlue <sup>®</sup> Level Alarm*	DEF/AdBlue <sup>®</sup> Is Insufficient. Refill DEF/AdBlue <sup>®</sup> . DEF Tank Empty. Engine Output Is Restricted.
 <div style="border: 1px solid black; padding: 2px; display: inline-block;">           REFILL DEF/AdBlue         </div> <div style="background-color: black; color: white; padding: 2px; display: inline-block; margin-left: 10px;">           No Power         </div>	DEF/AdBlue <sup>®</sup> Level Alarm*	DEF/AdBlue <sup>®</sup> Tank Is Empty. Refill DEF/AdBlue <sup>®</sup> . Engine Output And Speed Are Restricted.
 <div style="background-color: black; color: white; padding: 2px; display: inline-block;">           Exh. System         </div> 	Urea SCR System Malfunction*	Urea SCR System Is Broken.
 <div style="background-color: black; color: white; padding: 2px; display: inline-block;">           Exh. System         </div>  	Urea SCR System Malfunction*	Urea SCR System Is Broken. Engine Output Is Restricted.
 <div style="background-color: black; color: white; padding: 2px; display: inline-block;">           No Power Exh. System         </div> 	Urea SCR System Malfunction*	Urea SCR System Is Broken. Engine Output And Speed Are Restricted.

 NOTE: \*Alarm mark is displayed and buzzer will sound.

## OPERATOR'S STATION

- **Fuel Sensor Error Display**  
If the fuel sensor is faulty, the color of the fuel mark changes and the needle disappears. If the harness between the fuel sensor and the controller unit is broken, the needle disappears.
- **Coolant Temperature Sensor Error Display**  
If the coolant temperature sensor is faulty, the color of the temperature mark changes and the needle disappears. If the harness between the temperature sensor and the controller unit is broken, the needle disappears.

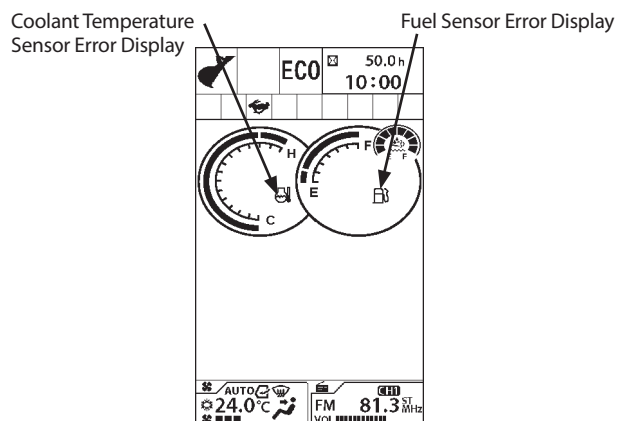

MDC1-01-024

- **Engine Speed Control Display**  
Engine warming-up operation due to low coolant temperature. The engine speed can not be changed during this operation. While the engine speed is controlled, mark (2) is displayed on monitor (1). When the control completes, mark (2) goes OFF and the engine speed becomes adjustable.

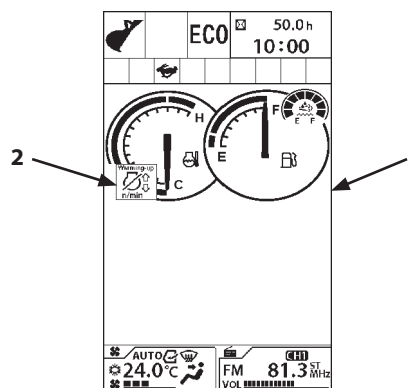

MDC1-01-355

## OPERATOR'S STATION

### Aftertreatment Device

#### Aftertreatment Device Condition Display

Aftertreatment Device Display (1) displays the condition of the aftertreatment device.



This mark indicates that the exhaust temperature is high during the aftertreatment device regeneration. It is lit while auto or manual regeneration is in process.



#### NOTE:

- The auto-regeneration is performed 30 hours after the previous regeneration. The auto-regeneration may start during operation of the machine; you can continue to operate the machine. The engine sound and/or the machine response to the operation of control levers may change when performing the auto-regeneration; this is not a malfunction.
- Do not stop the engine during regeneration unless absolutely necessary.

When the manual regeneration switch is pushed during the auto-regeneration process, the message "Minimal Exhaust Restriction. Exhaust Filter Cleaning Not Available." will be displayed on monitor (2).

Depending on the operating conditions of the machine, the regeneration may not be completed. In this case, an aftertreatment device regeneration request will be displayed on monitor (2). Immediately perform manual regeneration following the procedure.



This mark indicates that the aftertreatment device regeneration is inhibited. Regeneration will not be performed while this mark is lit.

**IMPORTANT: Set aftertreatment device regeneration to the inhibited position while operating the machine in an environment with materials that could be flammable. (Refer to the page 1-56)**

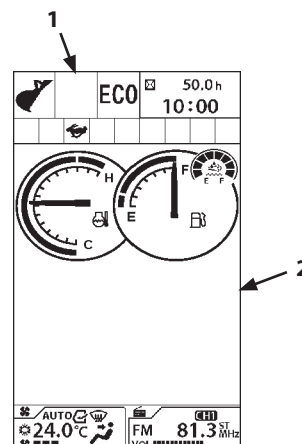

MDC1-01-001

## OPERATOR'S STATION

### Aftertreatment Device Manual Regeneration Request

The aftertreatment device needs regeneration. Usually, regeneration is performed automatically. However, manual regeneration is required depending on the conditions. The marks described below may be indicated on monitor (1).



(Blinking,  
Yellow)

This mark indicates that the aftertreatment device manual regeneration is required. Perform manual regeneration by following the specified procedure.



(Lighting,  
Yellow)

This mark indicates that the aftertreatment device regeneration is inhibited. Displayed when the manual regeneration request arises while aftertreatment device regeneration is inhibited. Move the machine to a safe place. Perform manual regeneration following the specified procedure.

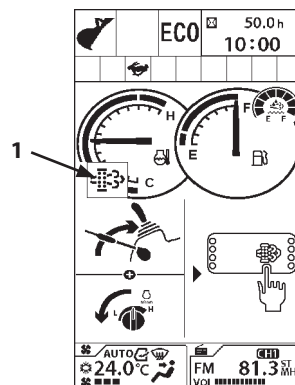

MDC1-01-005

### IMPORTANT:

- **Manual regeneration performed when the aftertreatment device regeneration request is displayed restores aftertreatment device function. This is not a malfunction.**
- **If the machine is continuously operated despite the aftertreatment device regeneration request is displayed, an engine trouble alarm will be displayed. Consult your authorized dealer.**



## OPERATOR'S STATION

### Manual Regeneration Procedure

When manual regeneration is needed, screen (1) as shown in the right will be displayed. When this screen (1) is displayed, you need to perform manual regeneration. Before starting manual regeneration, be sure to check the following.

If the rear view camera is equipped on the machine and the camera is enabled, screen (1) is displayed only when the pilot control shut-off lever is in LOCK position.

- No person is present around the machine.
  - Keep flammable materials away from the muffler.
  - Fuel level alarm is not lit.
  - DEF/AdBlue® level alarm does not light.
1. Park the machine in a safe place. Lower the front attachment onto the ground.
  2. Pull the pilot control shut-off lever to the LOCK position.
  3. Set the engine control dial to slow idle.
  4. Push aftertreatment device regeneration switch (2).
  5. When pushing aftertreatment device regeneration switch (2), screen (3) as shown in the right will be displayed and the manual regeneration starts. A bar graph on screen (3) shows the progress of the regeneration process.

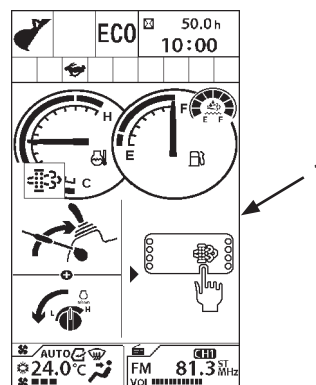

MDC1-01-005

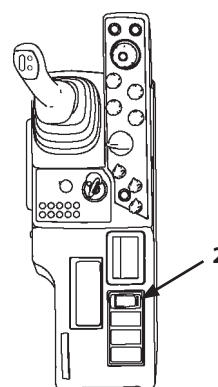

MDC1-01-543

**IMPORTANT: The manual regeneration does not start unless the pilot control shut-off lever is in the LOCK position and the engine control dial is in slow idle. When touching the pilot control shut-off lever or the engine control dial during manual regeneration, the regeneration process is aborted. When the process is aborted, start over again.**

6. When the manual regeneration is complete, the message "Regeneration Has Completed." is displayed. If "Regeneration Has Failed." message is displayed, start over the manual regeneration process once again. Failure of the regeneration process may happen in conditions other than those mentioned above (such as a malfunction of a sensor that affects regeneration, or at low ambient temperature).

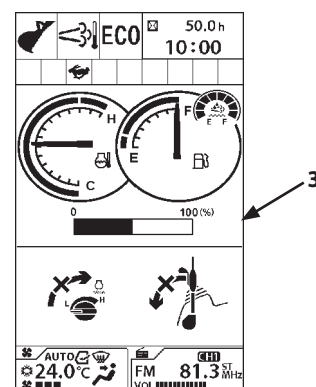

MDC1-01-006

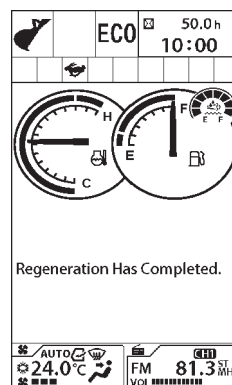

MDC1-01-083EN

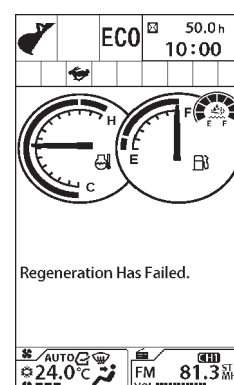

MDC1-01-084EN

# OPERATOR'S STATION

## Main Menu

Push selector knob (2) while displaying Basic Screen (1) to display Main Menu screen (3). Main Menu screen (3) contains the items as shown in the figure right. Engine Output Restriction Is Temporary Released, Urea SCR System Troubleshooting and Alarm List will be displayed only when the engine output is limited, Urea SCR system is malfunctioning or an alarm is generated, respectively. The mail (optional) menu will not be displayed unless it is set beforehand.

**NOTE:** The monitor automatically changes to Basic Screen (1) when it is not operated for 15 seconds or longer. If setting is terminated halfway, please restart the setting again.

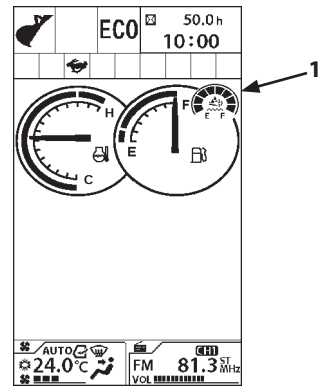

MDC1-01-001

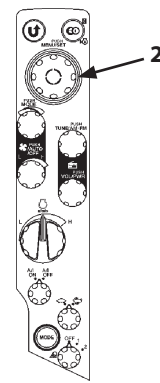

MDCD-01-026

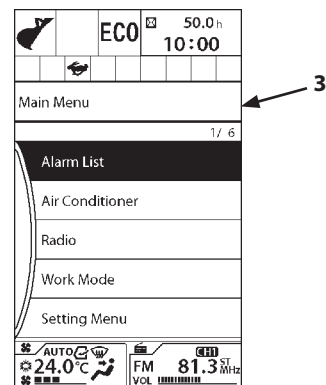

MDAA-01-077EN

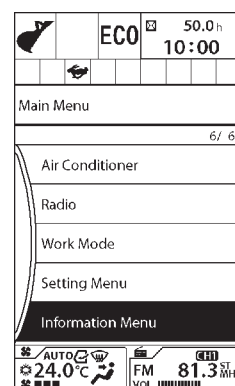

MDAA-01-190EN

## OPERATOR'S STATION

### Engine Output Restriction Suspend

When a lack of DEF/AdBlue® or Urea SCR system malfunction occurs, alarm mark (1) will be displayed on the basic screen and engine output / speed will be limited.

#### IMPORTANT:

- This function can be performed only one time at one engine output limit.
- This is only a temporary release operation. Refill DEF/AdBlue® or repair Urea SCR system as soon as possible. Consult your authorized dealer to repair the system.

The engine output limit function can be temporarily released when evacuation is unavoidable during machine operation. Follow the below procedure.

1. Push selector knob (2) on the Basic Screen to display Main Menu (3).
2. Rotate selector knob (2) to highlight Engine Output Restriction Suspend (4).

 **NOTE:** Engine output restriction suspend (4) is displayed on main menu (3) only when the engine output and speed is restricted.

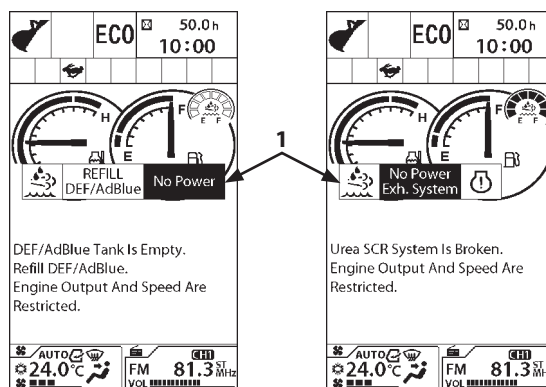

MDC1-01-519EN

MDC1-01-520EN

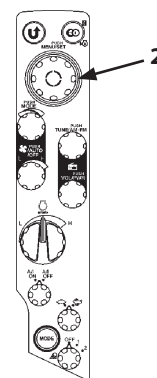

MDCD-01-026

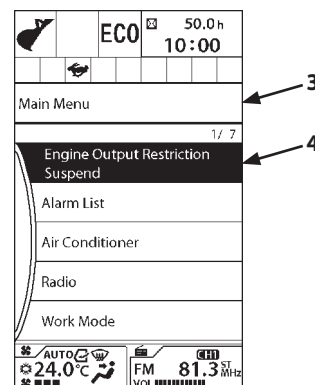

MDC1-01-521EN

## OPERATOR'S STATION

3. Push selector knob (2) to display Engine Output Restriction Suspend screen (5).

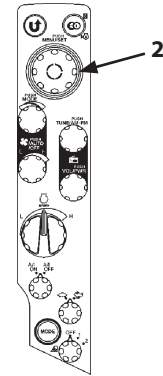

MDCD-01-026

4. Rotate selector knob (2) to highlight ✓ (6), and push selector knob (2) to display Engine Output Restriction Suspend screen (8).

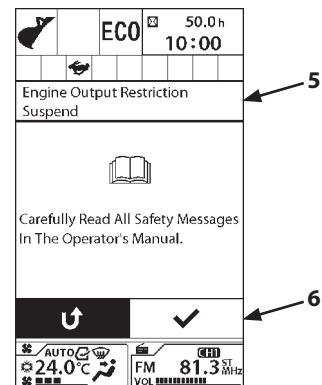

MDC1-01-522EN

5. Rotate selector knob (2) to highlight ✓ (7), then screen (9) is displayed and the engine output is temporarily released.

**NOTE:**

- The temporary release time is a maximum of 30 minutes.
- The engine output limit will be enabled after 30 minutes.

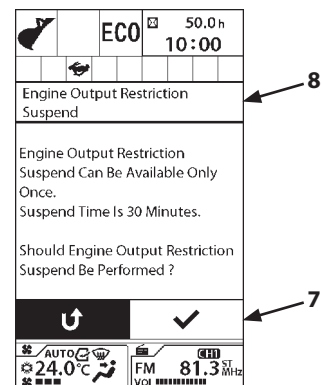

MDC1-01-523EN

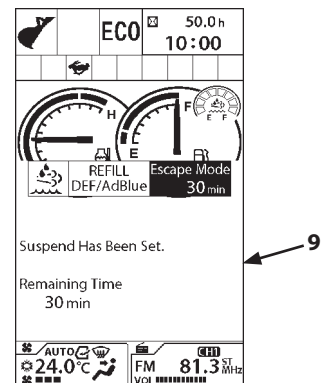

MDC1-01-524EN

## OPERATOR'S STATION

### Urea SCR System Troubleshooting

In case any abnormality occurs, alarm marks (1) are displayed on the Basic Screen. Follow the procedure below to display detailed information for an alarm.

1. Push selector knob (2) on the Basic Screen to display Main Menu screen (3).

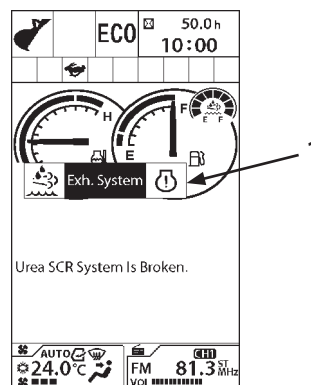

MDC1-01-514EN

2. Rotate selector knob (2) to highlight Urea SCR System Troubleshooting (4) and push selector knob (2).

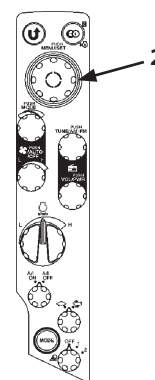

MDCD-01-026

3. Urea SCR System Troubleshooting screen (5) will be displayed and Urea SCR System Troubleshooting starts. Bar graph (6) on the screen indicates progress of the troubleshooting process.

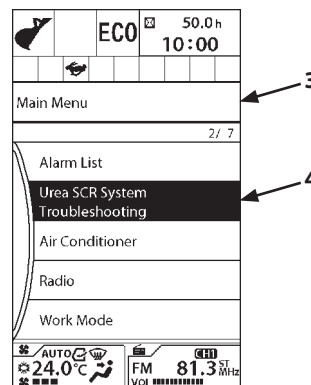

MDC1-01-515EN

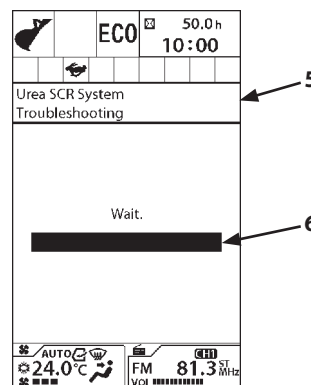

MDC1-01-516EN

## OPERATOR'S STATION

- When the troubleshooting is finished, fault code (7) is displayed. Consult your authorized dealer to repair the system.

 **NOTE:**

- The main menu displays information about the Urea SCR System Troubleshooting is only displayed when the Urea SCR system alarm is generated.
- Up to 20 fault codes are displayed in chronological order.

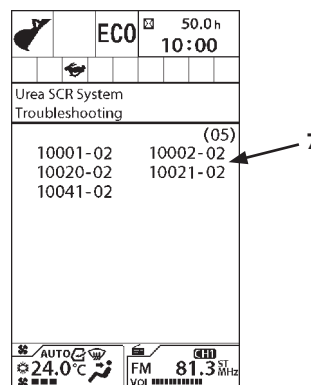

MDC1-01-517EN

# OPERATOR'S STATION

## Air Conditioner

Most air conditioner functions are operated by using switches (3) and (4), however air vent selection and turning A/C ON and OFF are performed from the air conditioner setting screen in the menu. (Refer to the page 1-115)

### Circulation Air Mode

1. Push selector knob (2) while displaying Basic Screen (1) to display Main Menu screen (5).
2. Rotate selector knob (2) to highlight Air Conditioner (6).
3. Push selector knob (2) to display Air Conditioner screen (7).
4. Rotate selector knob (2) to highlight  (8) mark.
5. Push selector knob (2) to set the circulation air mode.
6. Push selector knob (2) again to switch the fresh air mode.

### Air Conditioner ON/OFF

1. Rotate selector knob (2) to highlight A/C (9).
2. Push selector knob (2) to turn the air compressor ON.
3. Push selector knob (2) again to turn the air compressor OFF.

 **NOTE:** When the function is ON, the mark "■" is displayed in green. When the function is OFF, the mark "■" is displayed in gray.

**IMPORTANT:** If mark (10) is displayed on the air conditioner display, communication between the air conditioner and the monitor is abnormal. Consult your authorized dealer.

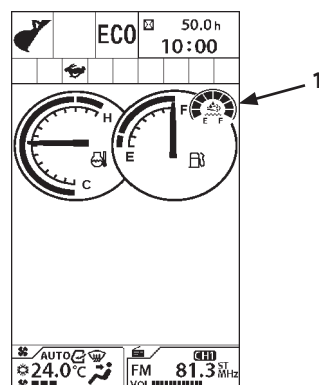

MDC1-01-001

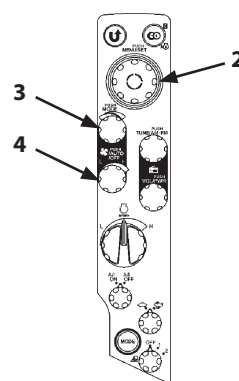

MDCD-01-026

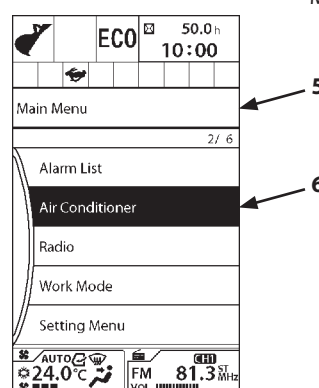

MDAA-01-089EN

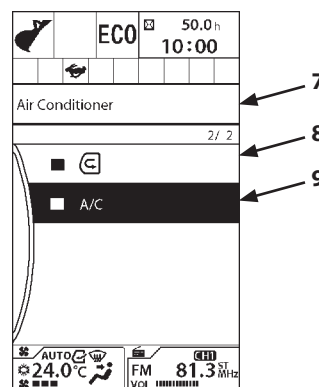

MDAA-01-091EN



MDAA-01-226

# OPERATOR'S STATION

## Radio

Most radio functions are operated by using switches (3) and (4), however memory channel setting, seek function, TONE adjustment, and AUTO PRESET are done at the radio screen in the main menu.

1. Push selector knob (2) while displaying Basic Screen (1) to display Main Menu screen (5).
2. Rotate selector knob (2) to highlight Radio (6).
3. Push selector knob (2) to display the radio screen.

(Refer to the page 1-121)

**IMPORTANT: If mark (7) is displayed on the radio display, communication between the radio and the monitor is abnormal. Consult your authorized dealer.**

While the radio is ON, pressing the numeric keypad 1 to 8 will change the radio station to the respective memorized channel.  
(Refer to the page 1-99 and 1-122)

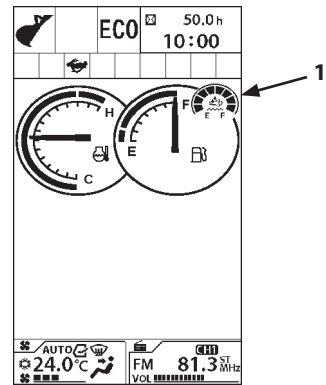

MDC1-01-001

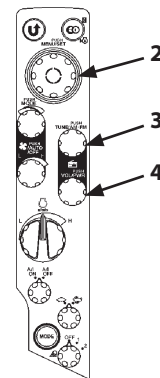

MDCD-01-026

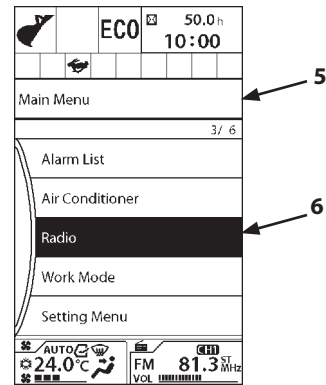

MDAA-01-092EN



MDAA-01-227



# OPERATOR'S STATION

## Work Mode

**IMPORTANT:** Before changing the work mode, stop the machine, lower the working device such as a bucket on the ground and pull the pilot control shut-off lever to the LOCK position.

Front attachment is selected in Work Mode screen (5) under the Work Mode menu in the main menu.

### Attachment Selection

1. Push selector knob (2) while displaying Basic Screen (1) to display Main Menu screen (3).
2. Rotate selector knob (2) to highlight Work Mode (4).
3. Push selector knob (2) to display Work Mode screen (5).
4. Rotate selector knob (2) to highlight the desired front attachment.  
(In the example on the right, Bucket (6) is highlighted.)
5. Push selector knob (2) to enable the changes.

 **NOTE:** When the attachment pedal is operated while the work mode is set to the digging mode, work mode display (7) on the monitor screen starts flashing.

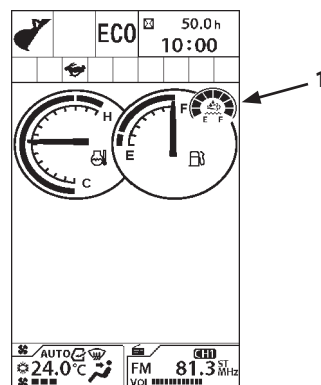

MDC1-01-001

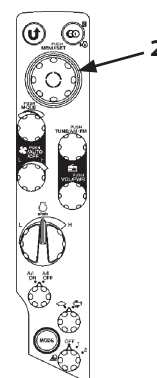

MDCD-01-026

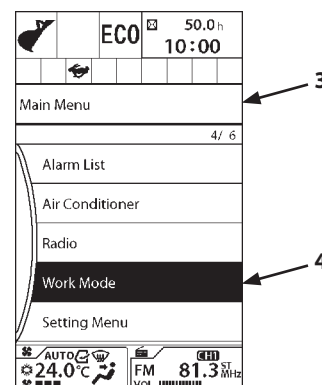

MDAA-01-100EN

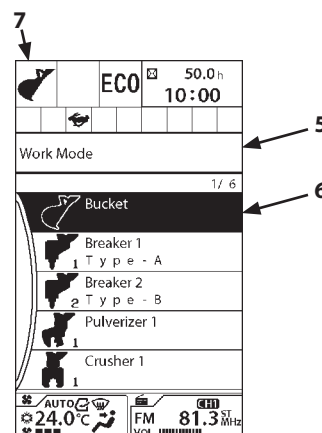

MDAA-01-101EN

# OPERATOR'S STATION

## Mail (Optional)

**IMPORTANT:** This function is available only to a machine equipped with a communication terminal. When using the mail function, consult your nearest Hitachi dealer.

1. Push selector knob (2) while displaying Basic Screen (1) to display Main Menu screen (3).
2. Rotate selector knob (2) to highlight Mail (4).
3. Push selector knob (2) to display Mail screen (5).
4. Rotate selector knob (2) to highlight desired request.
5. Push selector knob (2) to send mail information to the communication terminal.

- General Request
- Fuel Replenishment Request
- Service Maintenance Request
- Forwarding Request

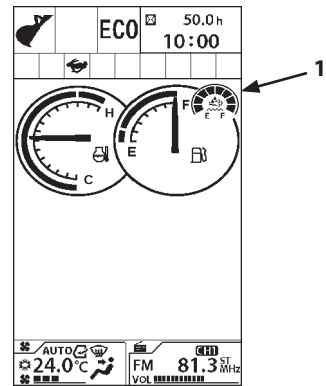

MDC1-01-001

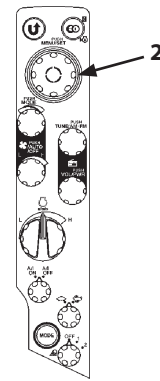

MDCD-01-026

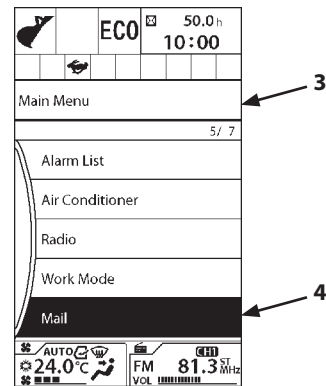

MDAA-01-109EN

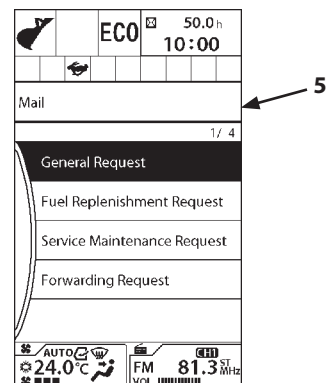

MDAA-01-110EN

## OPERATOR'S STATION

6. While mail information is sent to the communication terminal, the message "Wait." is displayed on the screen.

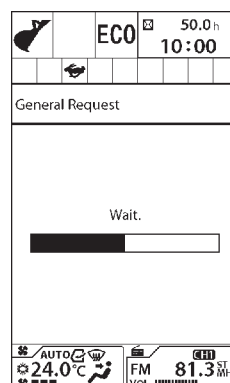

MDAA-01-111EN

7. When the communication terminal completes receiving mail information, the message "Request Is Accepted." is displayed on the screen.

Push the return to previous screen switch to return to the Mail screen.

8. Then, a mail is sent from the communication terminal to the central server.

### NOTE:

- Depending on the machine's operating environment, the mail may not be sent.
- When the communication terminal could not receive the mail, the message "Failed." is displayed on the screen.

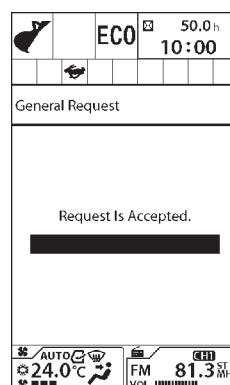

MDAA-01-112EN

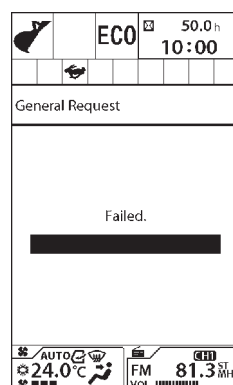

MDAA-01-113EN

## OPERATOR'S STATION

### Setting Menu

Setting menu consists of date and time setting, attachment adjustment, attachment name, auto shut-down setting, change password, selecting sub meter, brightness adjustment of rear view camera monitor and screen.

1. Push selector knob (2) while displaying Basic Screen (1) to display Main Menu screen (3).
2. Rotate selector knob (2) to highlight Setting Menu (4).
3. Push selector knob (2) to display Setting Menu screen (5).

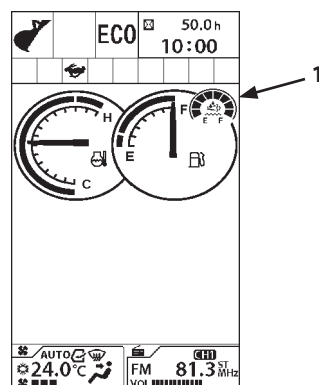

MDC1-01-001

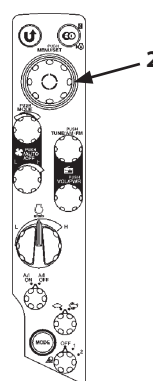

MDCD-01-026

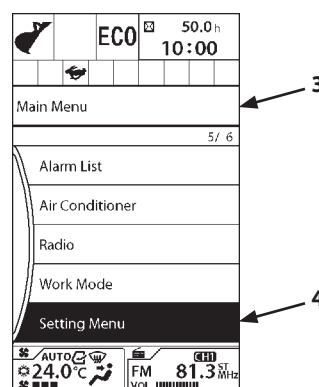

MDAA-01-114EN

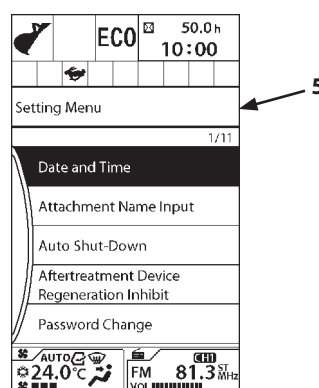

MDC1-01-115EN

# OPERATOR'S STATION

## Date and Time

Time, date and display mode can be set on this screen. Year-month-day format and 24h/12h display mode are selected in the display setting.

### Time Adjustment

1. Push selector knob (2) while displaying Basic Screen (1) to display Main Menu screen (3).
2. Rotate selector knob (2) to highlight Setting Menu (4).
3. Push selector knob (2) to display Setting Menu screen (5).
4. Rotate selector knob (2) to highlight Date and Time (6).

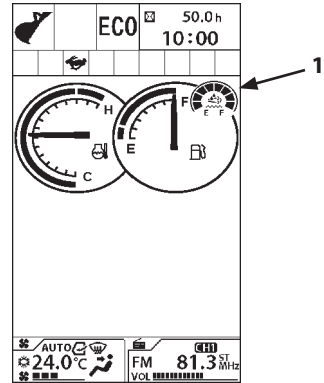

MDC1-01-001

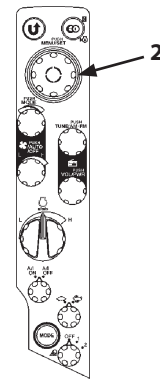

MDCD-01-026

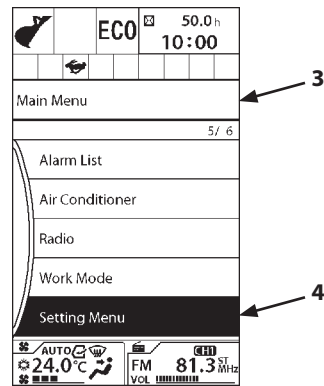

MDAA-01-114EN

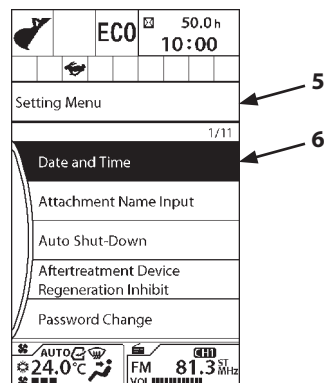

MDC1-01-115EN

## OPERATOR'S STATION

5. Push selector knob (2) to display Date and Time screen (7).

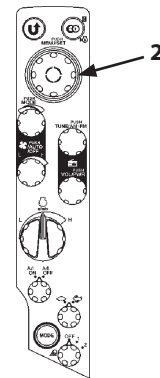

MDCD-01-026

6. Rotate selector knob (2) to highlight Time Setting (8).
7. Push selector knob (2) to display Time Setting screen (9).

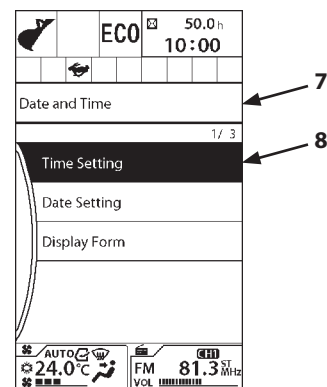

MDAA-01-117EN

8. Rotate selector knob (2) to highlight Hour or Minute (10) and push selector knob (2).
9. Rotate selector knob (2) to adjust the clock. Rotate clockwise to adjust the number upwards, and counterclockwise to decrease it.
10. Push selector knob (2) to end the Time setting procedure.
11. Rotate selector knob (2) to highlight ✓ (11). Push selector knob (2) to make the change.

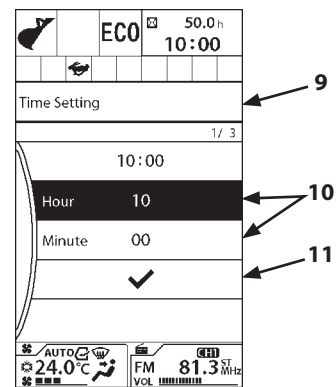

MDAA-01-118EN

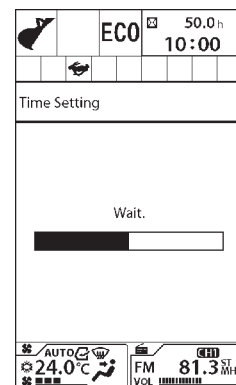

MDAA-01-121EN

## OPERATOR'S STATION

### Date Adjustment

1. Push selector knob (2) while displaying Basic Screen (1) to display Main Menu screen (3).
2. Rotate selector knob (2) to highlight Setting Menu (4).
3. Push selector knob (2) to display Setting Menu screen (5).
4. Rotate selector knob (2) to highlight Date and Time (6).

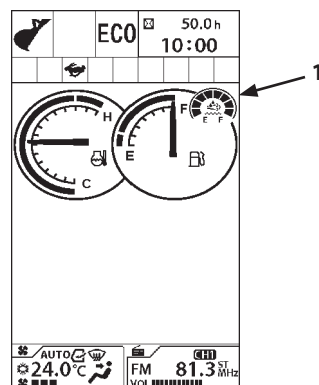

MDC1-01-001

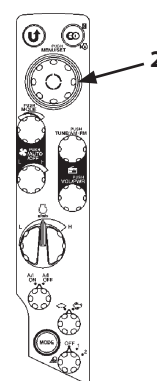

MDCD-01-026

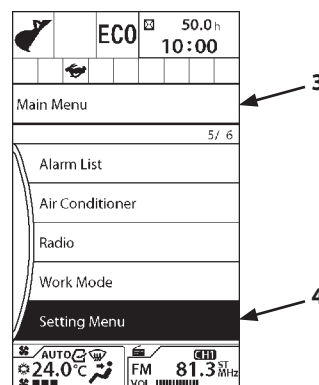

MDAA-01-114EN

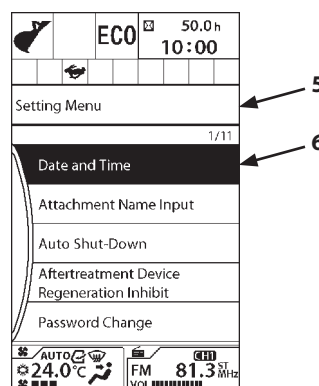

MDC1-01-115EN

## OPERATOR'S STATION

5. Push selector knob (2) to display Date and Time screen (7).

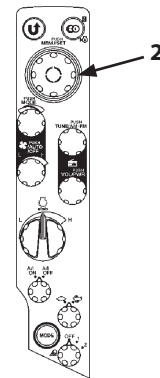

MDCD-01-026

6. Rotate selector knob (2) to highlight Date Setting (8).
7. Push selector knob (2) to display Date Setting screen (9).

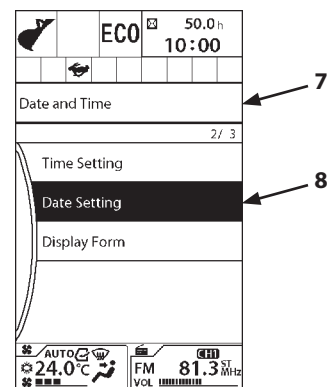

MDAA-01-122EN

8. Rotate selector knob (2) to highlight Year, Month or Day (10) and push selector knob (2).
9. Rotate selector knob (2) to adjust the clock. Rotate clockwise to adjust the number upwards, and counterclockwise to decrease it.
10. Push selector knob (2) to end the date setting procedure.
11. Rotate selector knob (2) to highlight ✓ (11). Push selector knob (2) to make the change.

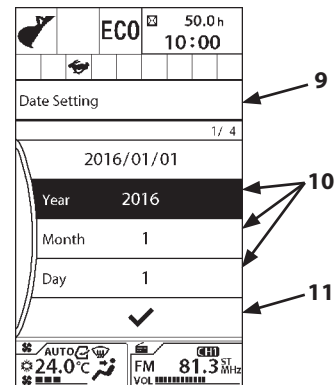

MDC1-01-123EN

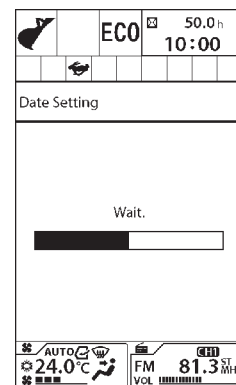

MDAA-01-127EN



## OPERATOR'S STATION

### Display Mode Setting

1. Push selector knob (2) while displaying Basic Screen (1) to display Main Menu screen (3).
2. Rotate selector knob (2) to highlight Setting Menu (4).
3. Push selector knob (2) to display Setting Menu screen (5).
4. Rotate selector knob (2) to highlight Date and Time (6).

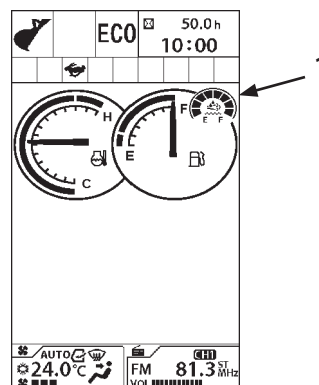

MDC1-01-001

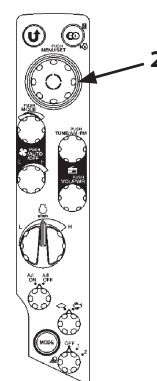

MDCD-01-026

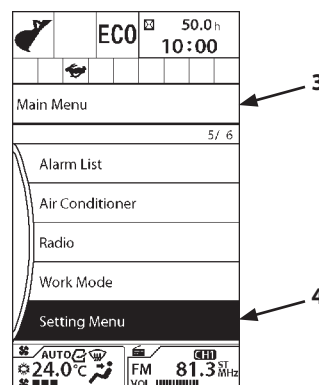

MDAA-01-114EN

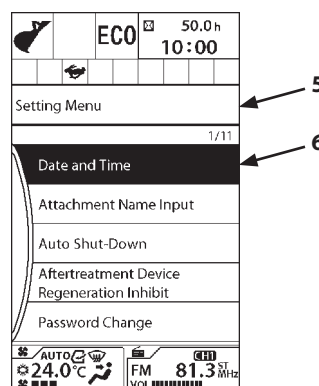

MDC1-01-115EN

# OPERATOR'S STATION

- Push selector knob (2) to display Date and Time screen (7).

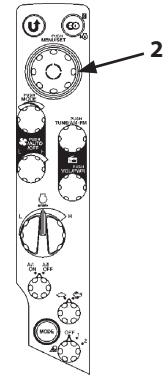

MDCD-01-026

- Rotate selector knob (2) to highlight Display Form (8).

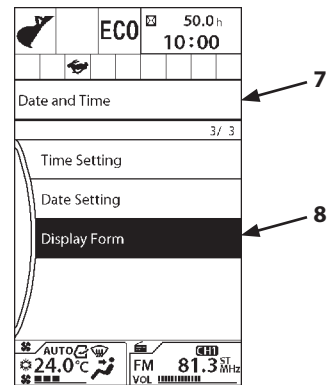

MDAA-01-228EN

- Push selector knob (2) to display Display Form screen (9).
- Rotate selector knob (2) to highlight Time or Date (10) and push selector knob (2).

**Time :** Each time selector knob (2) is pushed, the time format is changed as follows: 12 h → 24 h → 12 h.

**Date :** Each time selector knob (2) is pushed, the date format is changed as follows: YYYY/MM/DD → MM/DD/YYYY → DD/MM/YYYY → YYYY/MM/DD.

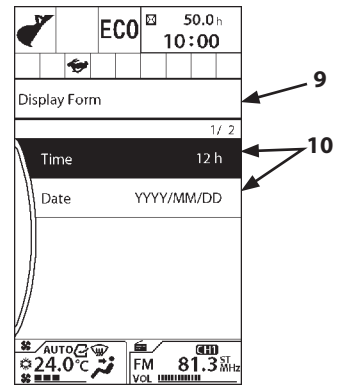

MDAA-01-229EN



MDAA-01-230EN



MDAA-01-231EN



MDAA-01-232EN



MDAA-01-233EN



MDAA-01-234EN

# OPERATOR'S STATION

## Attachment Adjustment

On the Attachment Adjustment screen, the supply flow rate to an attachment, the operational priority for combined operation of an attachment, and arm roll-in/arm roll-out can be adjusted.

Attachment adjustment can be done when the work mode is set to an attachment other than bucket. Select an attachment other than the bucket on the work mode screen. (Refer to "Work Mode")

### Flow Rate Adjustment

1. Push selector knob (2) while displaying Basic Screen (1) to display Main Menu screen (3).
2. Rotate selector knob (2) to highlight Setting Menu (4).
3. Push selector knob (2) to display Setting Menu screen (5).
4. Rotate selector knob (2) to highlight Attachment Adjustment (6).

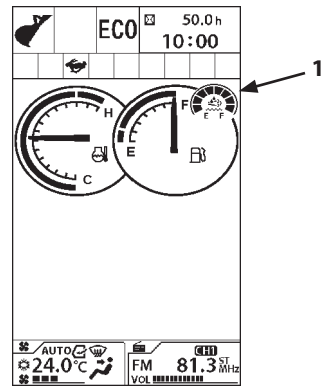

MDC1-01-001

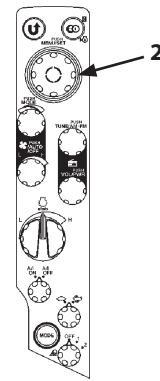

MDCD-01-026

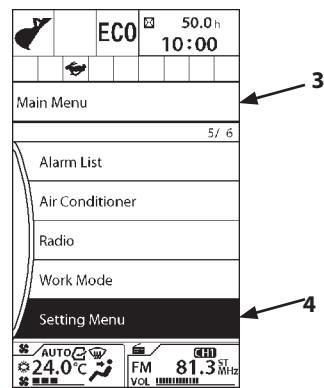

MDAA-01-114EN

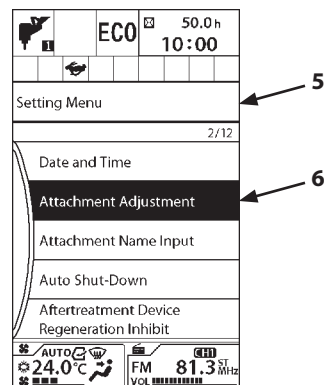

MDC1-01-128EN

## OPERATOR'S STATION

5. Push selector knob (2) to display Attachment Adjust screen (7).

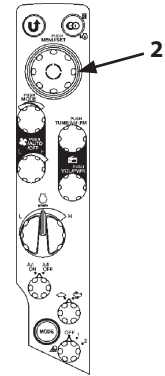

MDCD-01-026

6. Rotate selector knob (2) to highlight Pump Flow Rate (8).

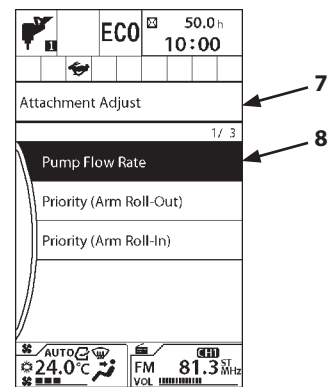

MDAA-01-129EN

7. Push selector knob (2) to display Pump Flow Rate screen (9).
8. Rotate selector knob (2) clockwise or counterclockwise to adjust the pump flow rate.

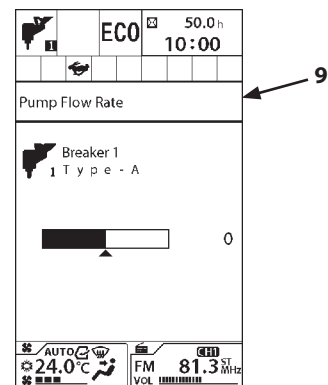

MDAA-01-130EN

## OPERATOR'S STATION

### Priority (arm roll-out)

Select an attachment other than the bucket on the work mode screen. (Refer to the page 1-36)

1. Push selector knob (2) while displaying Basic Screen (1) to display Main Menu screen (3).
2. Rotate selector knob (2) to highlight Setting Menu (4).
3. Push selector knob (2) to display Setting Menu screen (5).
4. Rotate selector knob (2) to highlight Attachment Adjustment (6).

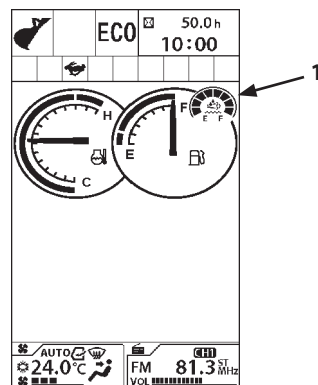

MDC1-01-001

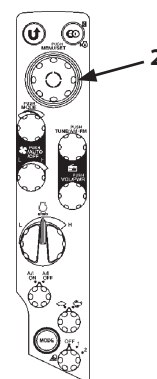

MDCD-01-026

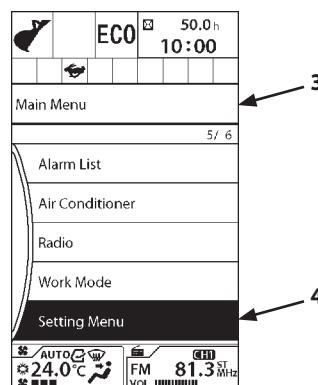

MDAA-01-114EN

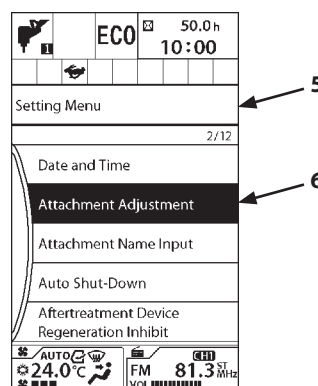

MDC1-01-128EN

## OPERATOR'S STATION

5. Push selector knob (2) to display Attachment Adjust screen (7).

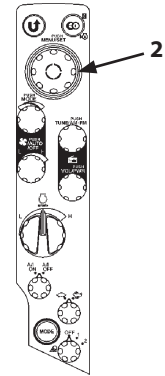

6. Rotate selector knob (2) to highlight Priority (Arm Roll-Out) (8).

MDCD-01-026

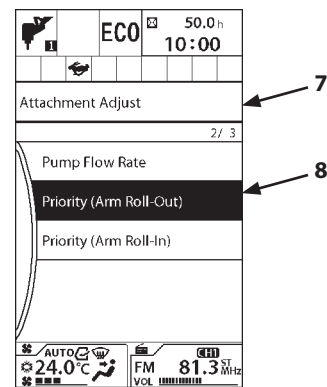

MDAA-01-235EN

7. Push selector knob (2) to display Priority (Arm Roll-Out) screen (9).
8. Rotate selector knob (2) clockwise to increase flow rate to the attachment. Rotate selector knob (2) counterclockwise to increase flow rate to the arm roll-out circuit.

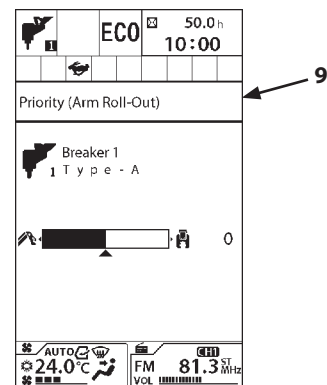

MDAA-01-132EN

## OPERATOR'S STATION

### Priority (arm roll-in) (Except ZX135US-6)

Select an attachment other than the bucket on the work mode screen. (Refer to the page 1-36)

1. Push selector knob (2) while displaying Basic Screen (1) to display Main Menu screen (3).
2. Rotate selector knob (2) to highlight Setting Menu (4).
3. Push selector knob (2) to display Setting Menu screen (5).
4. Rotate selector knob (2) to highlight Attachment Adjustment (6).

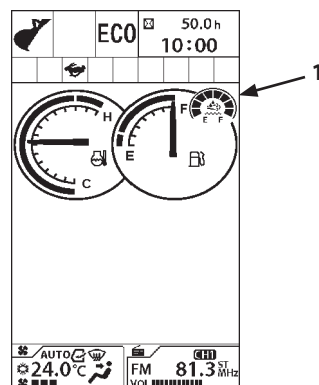

MDC1-01-001

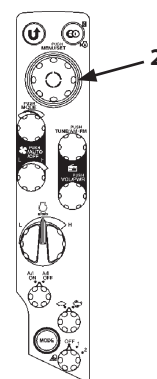

MDCD-01-026

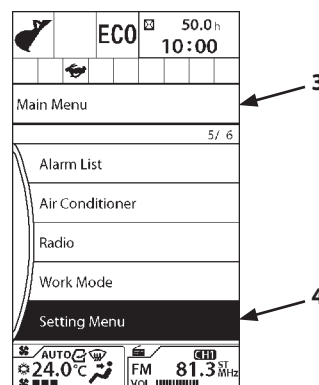

MDAA-01-114EN

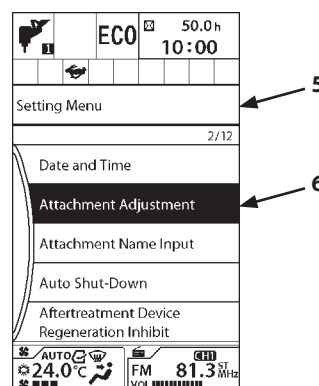

MDC1-01-128EN

## OPERATOR'S STATION

5. Push selector knob (2) to display Attachment Adjust screen (7).

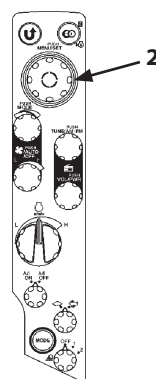

6. Rotate selector knob (2) to highlight Priority (Arm Roll-In) (8).

MDCD-01-026

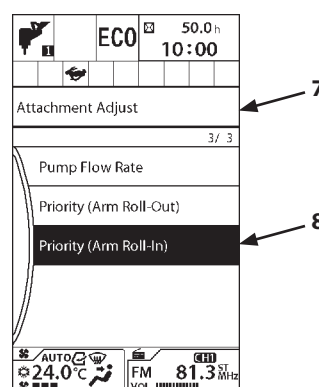

7. Push selector knob (2) to display Priority (Arm Roll-In) screen (9).

MDAA-01-236EN

8. Rotate selector knob (2) clockwise to increase flow rate to the attachment.

Rotate selector knob (2) counterclockwise to increase flow rate to the arm roll-in circuit.

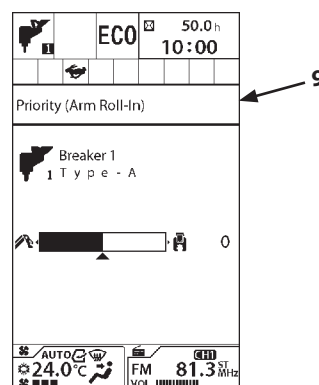

MDAA-01-131EN



## OPERATOR'S STATION

### Attachment Name Input

Attachment name can be changed on this screen.

1. Push selector knob (2) while displaying Basic Screen (1) to display Main Menu screen (3).
2. Rotate selector knob (2) to highlight Setting Menu (4).
3. Push selector knob (2) to display Setting Menu screen (5).
4. Rotate selector knob (2) to highlight Attachment Name Input (6).

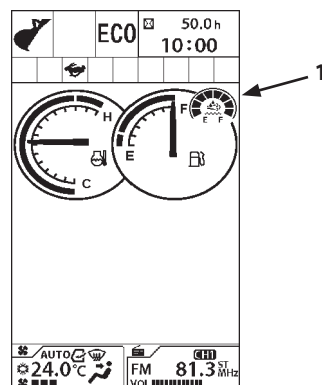

MDC1-01-001

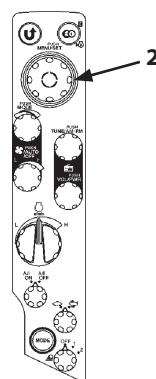

MDCD-01-026

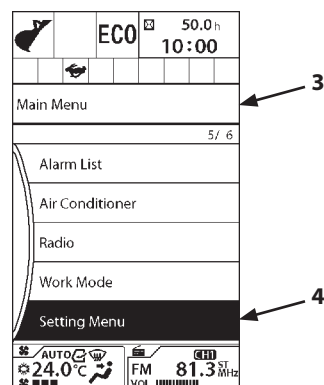

MDAA-01-114EN

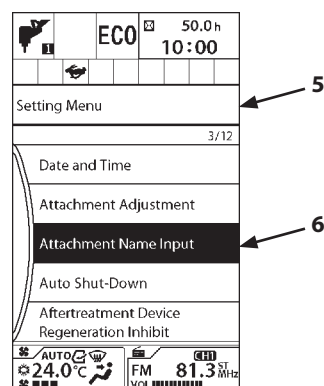

MDC1-01-133EN

## OPERATOR'S STATION

- Push selector knob (2) to display Attachment Name Input screen (7).

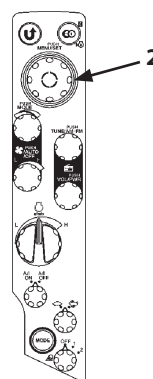

MDCD-01-026

- Rotate selector knob (2) to highlight Desired Attachment Name (8).

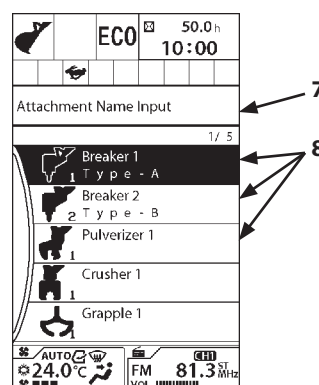

MDA A-01-134EN

- Push selector knob (2) to display Name Change screen (9).
- Rotate selector knob (2) right or left to highlight a character, and push selector knob (2).
- After inputting the new name, rotate selector knob (2) to highlight "SET". Push selector knob (2) to finalize the setting.

**NOTE:** In order to delete the last entered character, rotate selector knob (2) to highlight "BS" (Back Space), and then push selector knob (2). In order to delete all entered characters, rotate selector knob (2) to highlight "ALL CLEAR". Push selector knob (2).

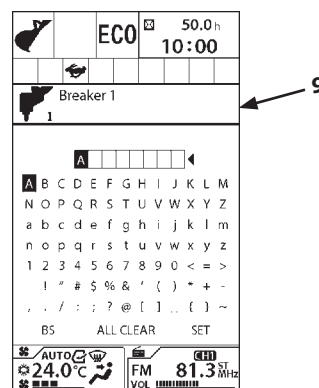

MDA A-01-137EN

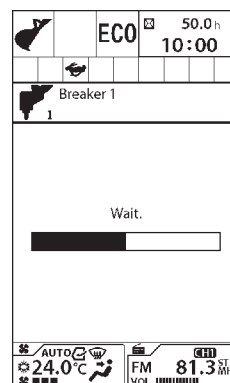

MDA A-01-145EN

## OPERATOR'S STATION

### Auto Shut-Down

**WARNING:** This function automatically stops the engine. Pay extra attention to the work and work environment when using this function.

The auto shut-down function can be set in this screen. Set the auto shut-down time and enable (ON) the function beforehand. The engine automatically stops after the preset time at the state in which the pilot control shut-off lever is pulled. 30 seconds before the engine stop, the monitor displays a message that engine will be stopped and the indicator starts flashing. The buzzer also sounds. The buzzer sounds once at 30 seconds before, and sounds continuously from 15 seconds before the stoppage. The engine speed decreases to the idling speed, and then stops after 15 seconds. When the pilot control shut-off lever is pushed before stopping the engine, the auto shut-down is disabled and the engine will not stop.

**IMPORTANT:** When the engine is stopped by the auto shut-down function, turn the key switch to ACC or OFF once, then turn it to START to restart the engine. Turn the key switch OFF after auto shut-down when leaving the machine for long period of time. Do not leave the machine after auto shut-down. Failure to do so may discharge the batteries.

#### Auto Shut-Down: ON/OFF

1. Push selector knob (2) while displaying Basic Screen (1) to display Main Menu screen (3).
2. Rotate selector knob (2) to highlight Setting Menu (4).
3. Push selector knob (2) to display Setting Menu screen (5).
4. Rotate selector knob (2) to highlight Auto Shut-Down (6).

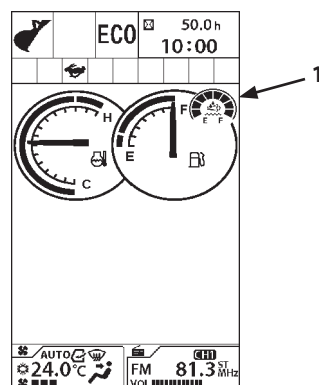

MDC1-01-001

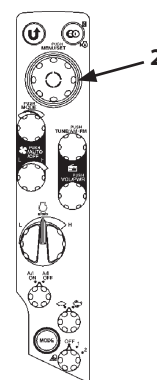

MDCD-01-026

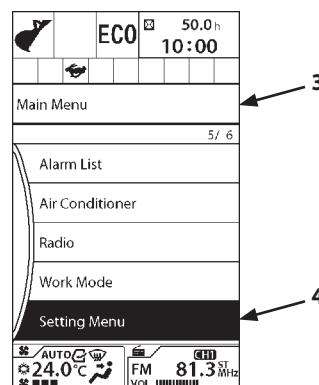

MDAA-01-114EN

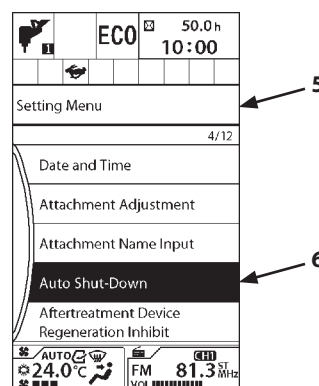

MDC1-01-147EN

## OPERATOR'S STATION

- Push selector knob (2) to display Auto Shut-Down screen (7).

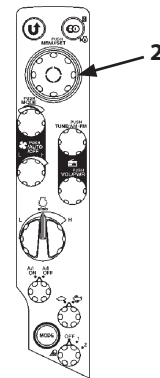

MDCD-01-026

- Rotate selector knob (2) to highlight ON (Enable) (8).
- Push selector knob (2) to set the auto shut-down function ON. Push selector knob (2) again to turn the auto shut-down function OFF.

 **NOTE:** When the function is ON, the mark "■" is displayed in green. When the function is OFF, the mark "■" is displayed in gray.

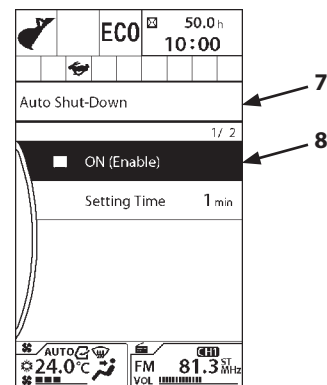

MDAA-01-148EN

### Auto Shut-Down: Setting Time

- On Auto Shut-Down screen (7), rotate selector knob (2) to highlight Setting Time (9) and push selector knob (2).
- Rotate selector knob (2) to adjust the Auto Shut-Down activation.
- Push selector knob (2) to make the change.

 **NOTE:** 30 seconds before the engine stops, the monitor will display "Engine Shut-Down Soon." message (10).

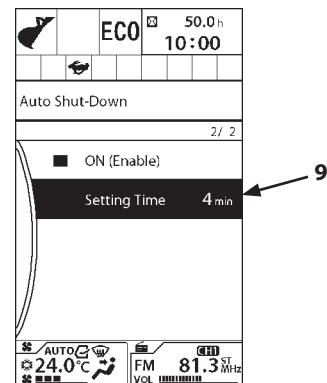

MDAA-01-150EN

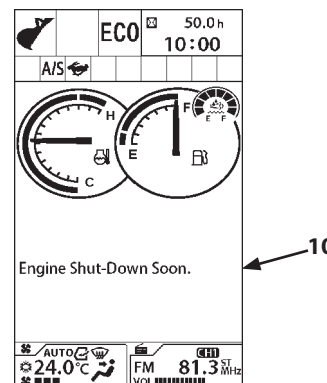

MDC1-01-146EN

# OPERATOR'S STATION

## Aftertreatment Device Regeneration Inhibited

**IMPORTANT:** The aftertreatment device regeneration can be inhibited at this screen to prevent auto regeneration while operating the machine in a dusty area or indoors.

### Setting Procedure

1. Push selector knob (2) while displaying Basic Screen (1) to display Main Menu screen (3).

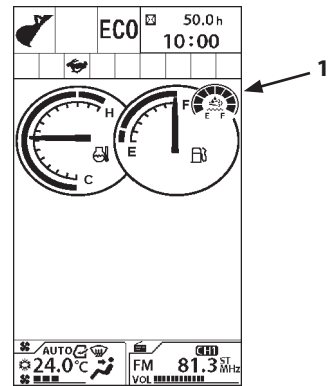

MDC1-01-001

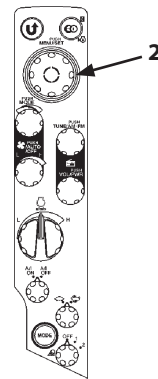

MDCD-01-026

2. Rotate selector knob (2) to highlight Setting Menu (4).

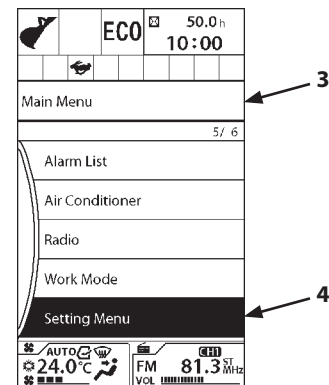

MDAA-01-114EN

## OPERATOR'S STATION

3. Push selector knob (2) to display Setting Menu screen (5).
4. Rotate switch (2) to highlight Aftertreatment Device Regeneration inhibited (6).
5. Push selector knob (2) to display aftertreatment device regeneration inhibited screen (7).
6. Rotate selector knob (2) to highlight ✓ (8), and push selector knob (2) to display Aftertreatment Device Regeneration Inhibited screen (9).
7. Rotate switch (2) to highlight ON (10). Confirmation screen is added.
8. Push selector knob (2) to turn aftertreatment device Regeneration Inhibited ON. Push selector knob (2) again to turn aftertreatment device Regeneration Inhibited OFF.
9. When ON is selected, the regeneration inhibited icon will be displayed on the monitor. (Refer to the page 1-26)

 **NOTE:** When the auto shut-down function is ON, the mark "■" is displayed in orange. When the auto shut-down function is OFF, the mark "■" is displayed in gray.

**IMPORTANT:** When the aftertreatment device regeneration request is displayed, move the machine to a safe place. Perform the manual regeneration by following the specified procedure. Failure to do so may damage the aftertreatment device. Refer to "Aftertreatment Device" section (1-28, 5-10) for the manual regeneration.

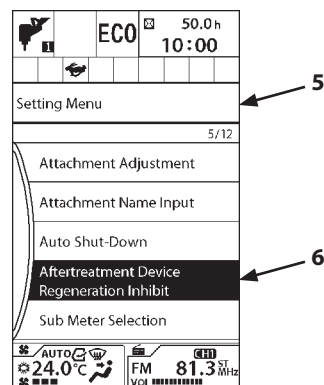

MDC1-01-283EN

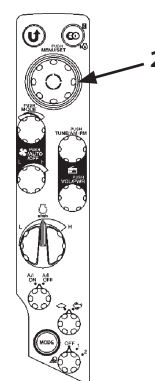

MDCD-01-026

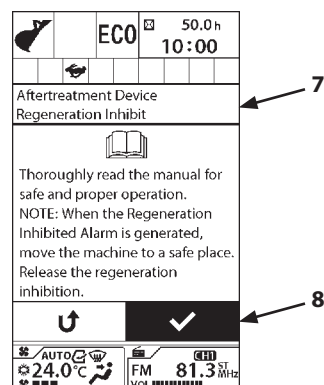

MDC1-01-325EN

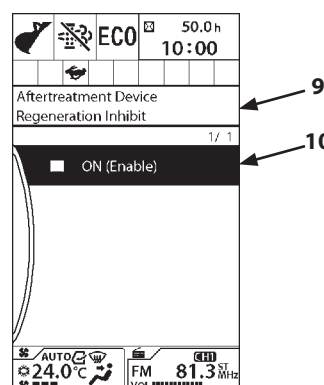

MDC1-01-284EN

# OPERATOR'S STATION

## Password Change (Optional)

- 1. Push selector knob (2) while displaying Basic Screen (1) to display Main Menu screen (3).

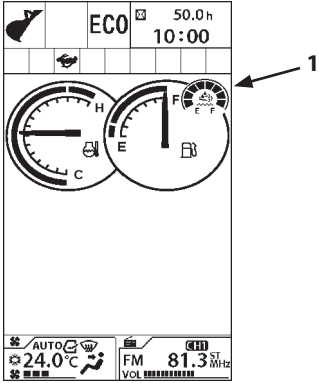

MDC1-01-001

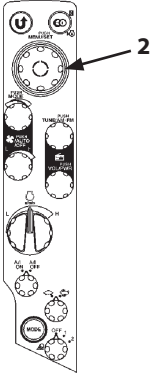

MDCD-01-026

- 2. Rotate selector knob (2) to highlight Setting Menu (4).

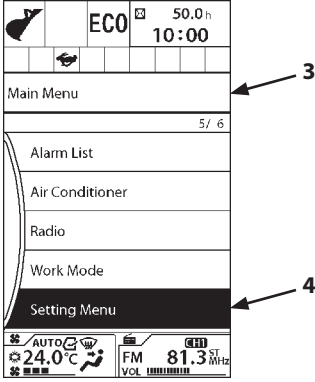

MDAA-01-114EN

## OPERATOR'S STATION

3. Push selector knob (2) to display Setting Menu screen (5).
4. Rotate selector knob (2) to highlight Password Change (6).

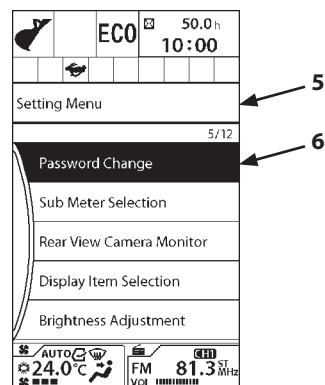

MDAA-01-156EN

5. Push selector knob (2) to display Password Change screen (7).

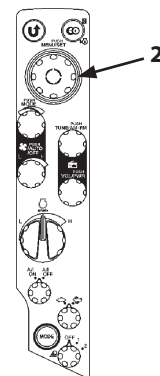

MDCD-01-026

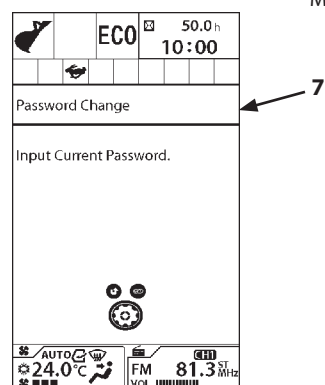

MDAA-01-157EN

6. Input current password from the numeric keypad.

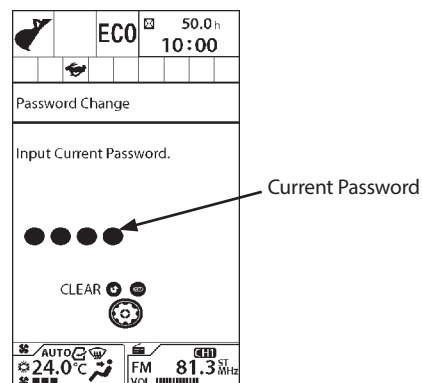

MDAA-01-158EN



# OPERATOR'S STATION

- 7. Input the new password and push selector knob (2). 3 to 8 digits can be input for password.

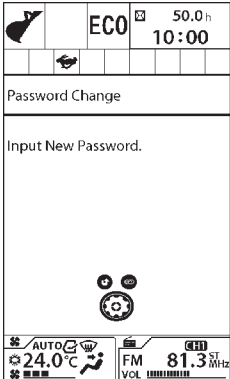

MDAA-01-159EN

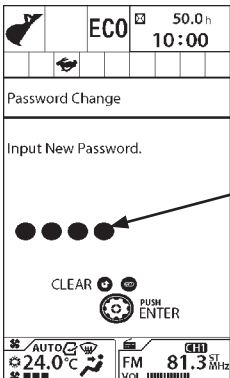

MDAA-01-160EN

# OPERATOR'S STATION

8. Input the new password again to confirm it and push selector knob (2).

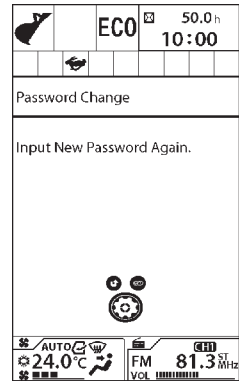

MDAA-01-161EN

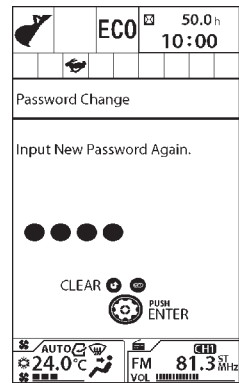

MDAA-01-162EN

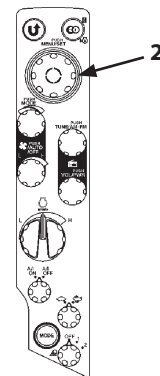

MDCD-01-026

9. The password has been changed.

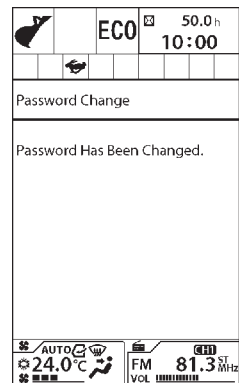

MDAA-01-163EN

# OPERATOR'S STATION

## Sub Meter

A sub meter selection menu that can be added to the fuel meter is selected on this screen. OFF, Fuel Consumption Indicator and Breaker Hour Meter are provided. The breaker hour meter indicates the breaker operation time.

1. Push selector knob (2) while displaying Basic Screen (1) to display Main Menu screen (3).
2. Rotate selector knob (2) to highlight Setting Menu (4).
3. Push selector knob (2) to display Setting Menu screen (5).
4. Rotate selector knob (2) to highlight Sub Meter Selection (6).

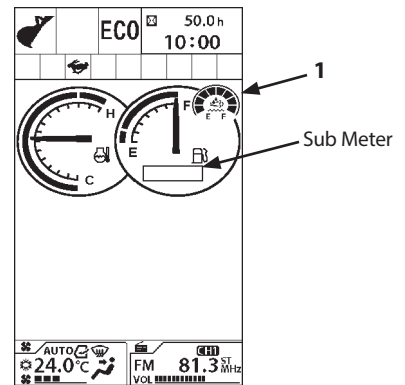

MDC1-01-315

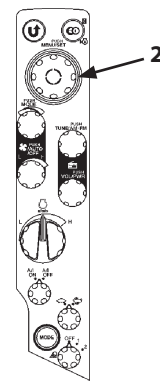

MDCD-01-026

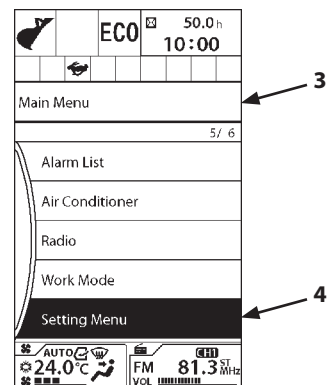

MDAA-01-114EN

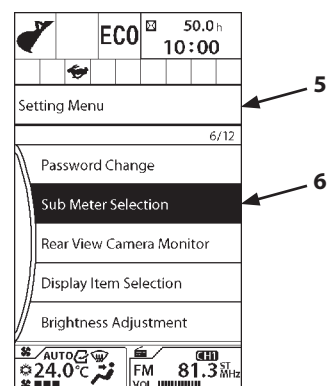

MDAA-01-164EN

## OPERATOR'S STATION

5. Push selector knob (2) to display Sub Meter Selection screen (7).

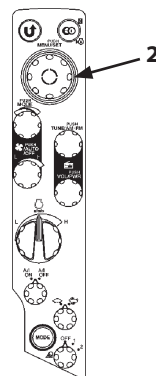

MDCD-01-026

6. Rotate selector knob (2) to highlight Desired Sub Meter (8). (Selecting OFF will not display a sub meter.)
7. Push selector knob (2) to enable the changes.



**NOTE:**

- Only one sub meter can be selected at a time.
- When a display is selected, the mark "■" is displayed in green. When not selected, the mark "■" is displayed in gray.

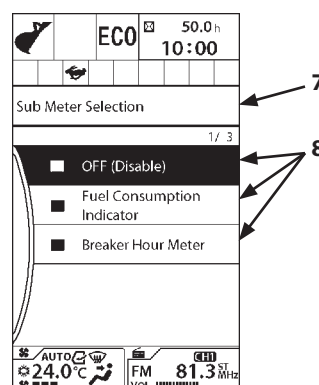

MDAA-01-165EN

## OPERATOR'S STATION

### Brightness Adjustment

1. Push selector knob (2) while displaying Basic Screen (1) to display Main Menu screen (3).

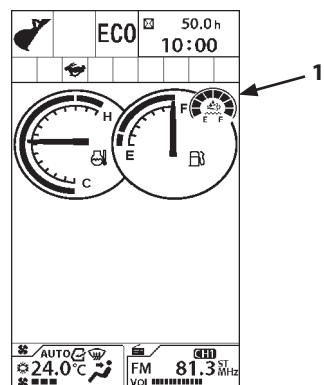

MDC1-01-001

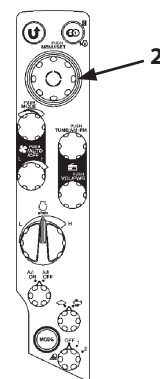

MDCD-01-026

2. Rotate selector knob (2) to highlight Setting Menu (4).

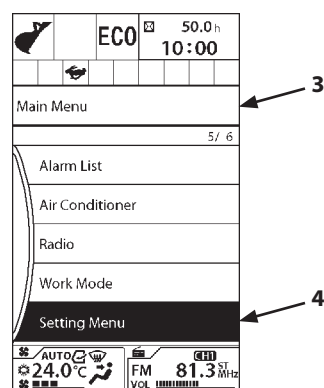

MDAA-01-114EN

3. Push selector knob (2) to display Setting Menu screen (5).
4. Rotate selector knob (2) to highlight Brightness Adjustment (6).

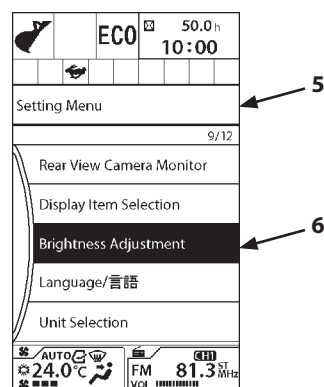

MDAA-01-171EN

## OPERATOR'S STATION

5. Push selector knob (2) to display Brightness Adjustment screen (7).

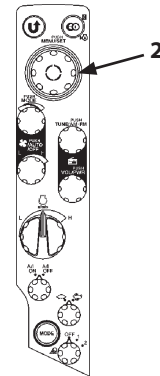

MDCD-01-026

6. Rotate selector knob (2) clockwise to make the screen brighter, counterclockwise to make the screen darker.

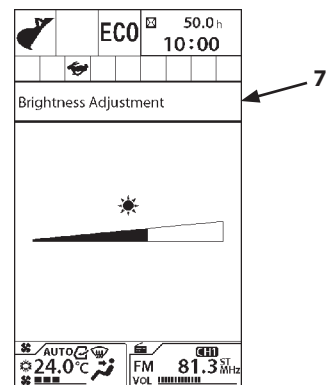

MDAA-01-172EN

 **NOTE:**

- When the light is turned ON, the monitor screen changes to night mode and mark (8) is displayed. Brightness can be adjusted for day mode and night mode respectively.
- Even if the light is turned ON during daytime, you can activate the daytime screen by pushing "0" (9) on the numeric keypad.

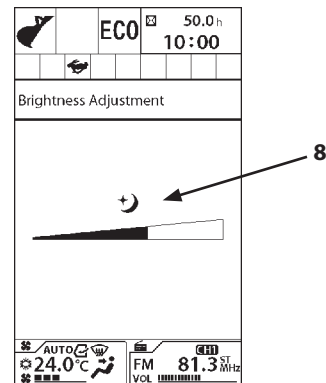

MDAA-01-173EN

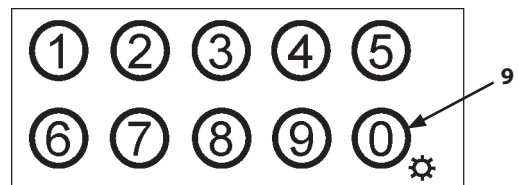

MDAA-01-018

# OPERATOR'S STATION

## Language Settings

1. Push selector knob (2) while displaying Basic Screen (1) to display Main Menu screen (3).

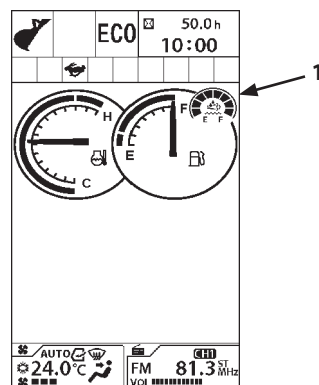

MDC1-01-001

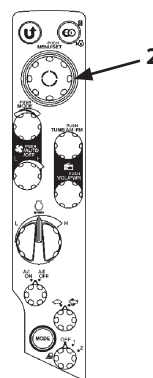

MDCD-01-026

2. Rotate selector knob (2) to highlight Setting Menu (4).

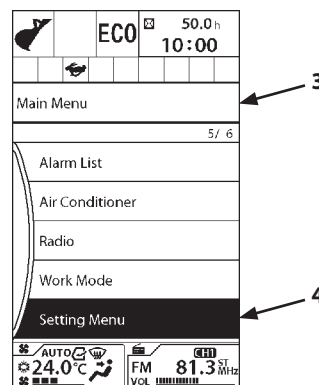

MDAA-01-114EN

3. Push selector knob (2) to display Setting Menu screen (5).
4. Rotate selector knob (2) to highlight Language/言語 (6).

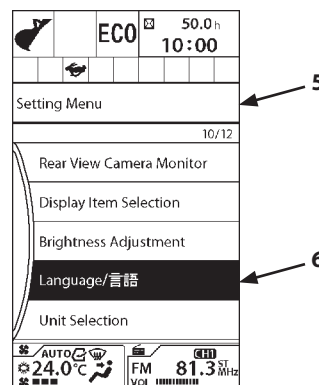

MDAA-01-176EN

## OPERATOR'S STATION

5. Push selector knob (2) to display Language/言語 screen (7).

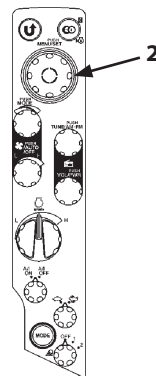

6. Rotate selector knob (2) to highlight the desired language. Push selector knob (2) to make the change.

 **NOTE:** When a display is selected, the mark "■" is displayed in green. When not selected, the mark "■" is displayed in gray.

MDCD-01-026

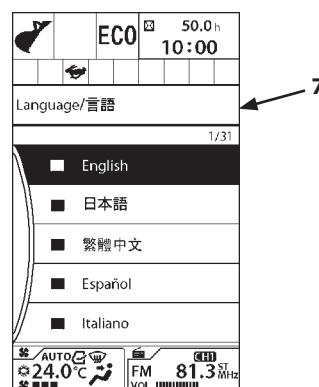

MDAA-01-177EN



## OPERATOR'S STATION

### Lists of Display Language

Language	Screen Display
Japanese	日本語
English	English
Spanish	Español
Italian	Italiano
French	Français
German	Deutsch
Dutch	Nederlands
Russian	Русский
Portuguese	Português
Finnish	Suomi
Greek	Ελληνικά
Swedish	Svenska
Norwegian	Norsk
Chinese (Simplified)	简体中文
Chinese (Traditional)	繁體中文
Korean	한국어

Language	Screen Display
Indonesian	Bahasa Indonesia
Thai	ภาษาไทย
Vietnamese	Tiếng Việt
Myanmarese	မြန်မာစာစကား
Arabic	اللغة العربية
Persian	زبان فارسی
Turkish	Türkçe
Danish	Dansk
Estonian	Eesti
Polish	Polski
Icelandic	Íslenska
Croatian	Hrvatski
Slovenian	Slovenščina
Romanian	limba română
Bulgarian	Български език
Lithuanian	Lietuvių kalba

# OPERATOR'S STATION

## Unit Selection

Unit system displayed on the monitor can be selected in this screen.

1. Push selector knob (2) while displaying Basic Screen (1) to display Main Menu screen (3).

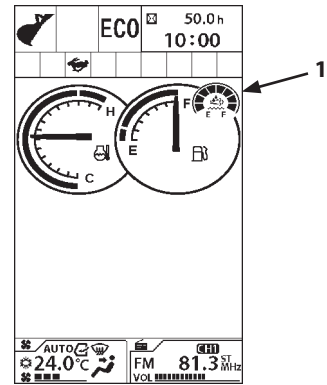

MDC1-01-001

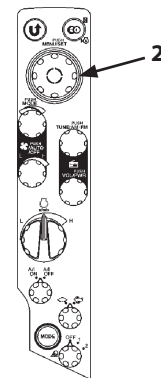

MDCD-01-026

2. Rotate selector knob (2) to highlight Setting Menu (4).

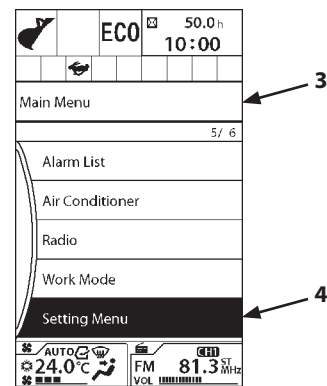

MDAA-01-114EN

3. Push selector knob (2) to display Setting Menu screen (5).
4. Rotate selector knob (2) to highlight Unit Selection (6).

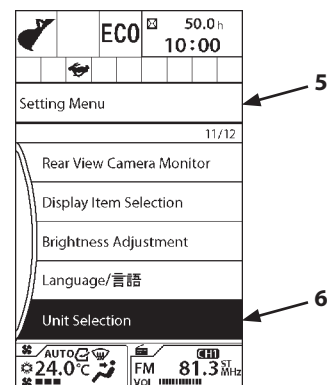

MDAA-01-181EN

## OPERATOR'S STATION

5. Push selector knob (2) to display Unit Selection screen (7).

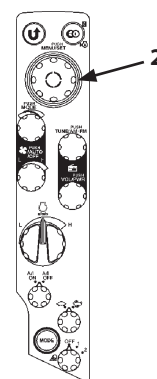

MDCD-01-026

6. Rotate selector knob (2) to highlight the Desired Unit System. Push selector knob (2) to set the unit (Metric or US system).

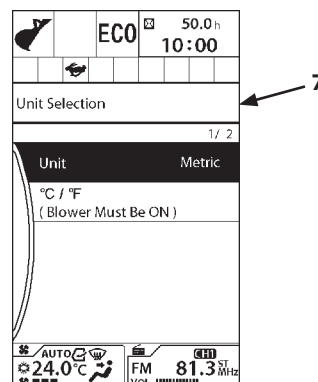

MDAA-01-182EN

7. Before changing °C and °F, turn the blower of the air conditioner ON.

Rotate selector knob (2) to highlight desired unit system (°C or °F). Push selector knob (2) to set the unit.

When pressing selector knob (2), "Wait." will be displayed and then the change will be completed.

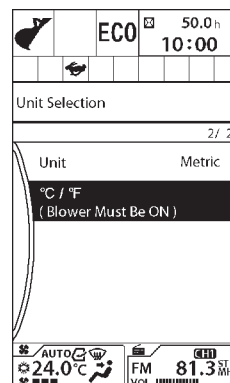

MDAA-01-183EN

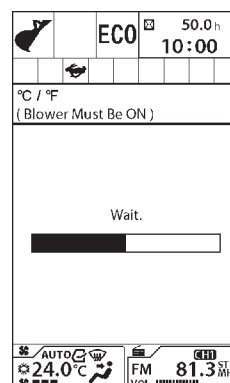

MDAA-01-184EN

## OPERATOR'S STATION

### Display Item Selection (Rear View Camera OFF)

The display under the meters can be set to OFF (disable), Logo or Operational information.

1. Push selector knob (2) while displaying Basic Screen (1) to display Main Menu screen (3).

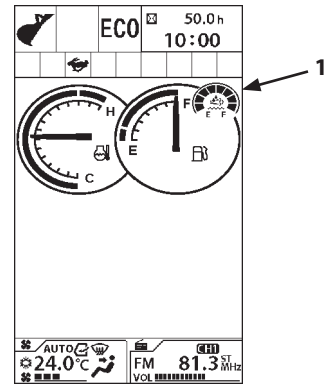

MDC1-01-001

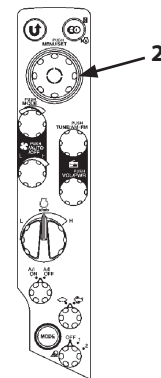

MDCD-01-026

2. Rotate selector knob (2) to highlight Setting Menu (4).

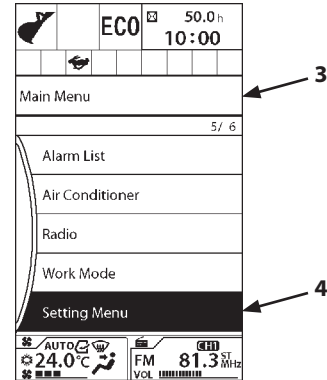

MDAA-01-114EN

3. Push selector knob (2) to display Setting Menu screen (5).
4. Rotate selector knob (2) to highlight Display Item Selection (6).

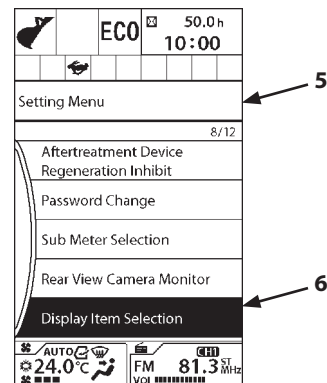

MDC1-01-237EN

## OPERATOR'S STATION

5. Push selector knob (2) to display Display Item Selection screen (7).

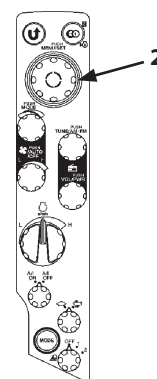

6. Rotate selector knob (2) to highlight the Desired Display. Push selector knob (2) to set the image. (Selecting OFF sets non-display.)

 **NOTE:** When a display is selected, the mark "■" is displayed in green. When not selected, the mark "■" is displayed in gray.

MDCD-01-026

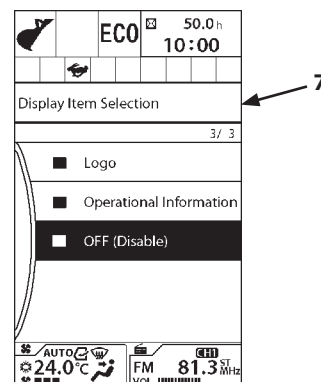

MDAA-01-238EN

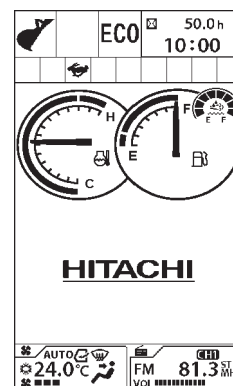

Logo

MDC1-01-239

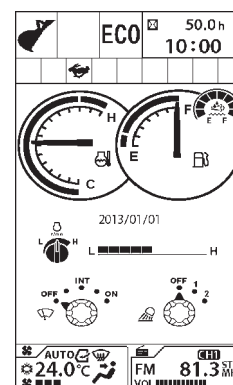

Operation Information

MDC1-01-222

## OPERATOR'S STATION

### Main Menu Sequence Change

Menu sequence of Air Conditioner, Radio and Work Mode can be changed in this screen. Frequently used menu can be located on top of the screen.

1. Push selector knob (2) while displaying Basic Screen (1) to display Main Menu screen (3).

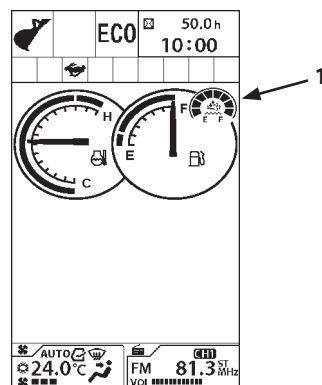

MDC1-01-001

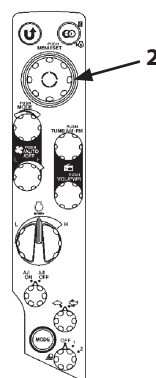

MDCD-01-026

2. Rotate selector knob (2) to highlight Setting Menu (4).

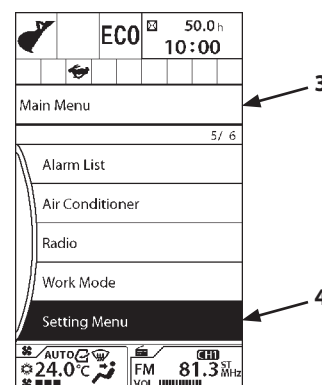

MDAA-01-114EN

## OPERATOR'S STATION

3. Push selector knob (2) to display Setting Menu screen (5).
4. Rotate selector knob (2) to highlight Main Menu Sequence Change (6).

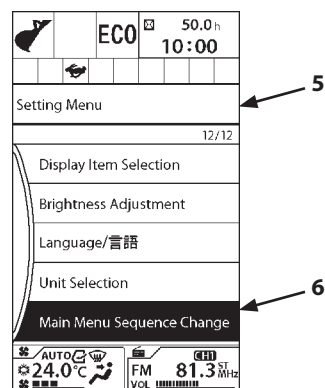

MDAA-01-186EN

5. Push selector knob (2) to display Main Menu Sequence Change screen (7).

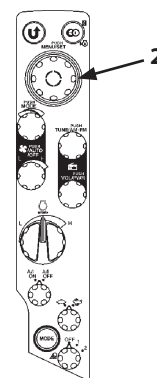

MDCD-01-026

6. Rotate selector knob (2) to highlight a menu to be on the top of the screen. Push selector knob (2) to set the menu to the top of the screen.

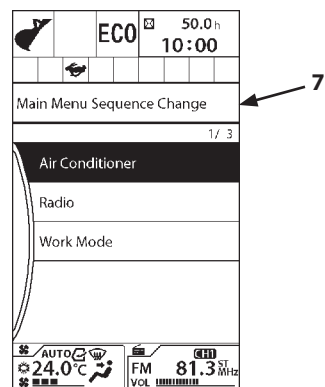

MDAA-01-187EN

# OPERATOR'S STATION

## Information Menu

The information menu includes Operation, Maintenance, Troubleshooting and Monitoring.

1. Push selector knob (2) while displaying Basic Screen (1) to display Main Menu screen (3).
2. Rotate selector knob (2) to highlight Information Menu (4).
3. Push selector knob (2) to display Information Menu screen (5).

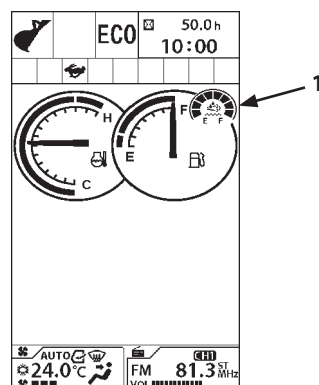

MDC1-01-001

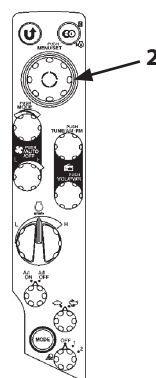

MDCD-01-026

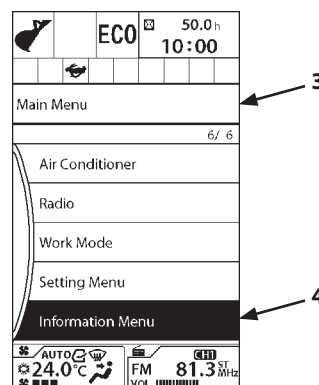

MDAA-01-190EN

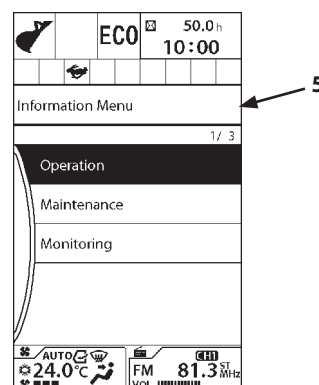

MDAA-01-191EN



# OPERATOR'S STATION

## Operation

The Operation screen displays Fuel Consumption, Breaker Operation, Attachment Operation, Travel Operation, and Actual Operation menus. The Fuel Consumption screen displays fuel consumption, operating hours, and fuel consumption rate, for the period since the monitoring unit was last reset. The Breaker Operation screen displays breaker operating hours, machine operating hours and operating rate, for the period since the monitoring unit was last reset. The Attachment Operation screen displays total operating hours of front attachment, travel and all operation for the period since the monitoring unit was last reset.

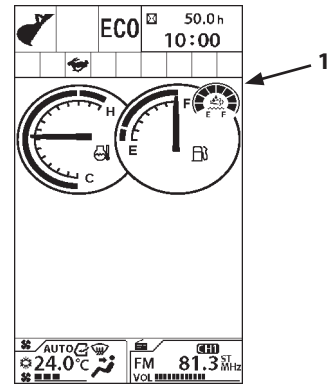

MDC1-01-001

## Fuel Consumption

1. Push selector knob (2) while displaying Basic Screen (1) to display Main Menu screen (3).
2. Rotate selector knob (2) to highlight Information Menu (4).
3. Push selector knob (2) to display Information Menu screen (5).
4. Rotate selector knob (2) to highlight Operation (6).

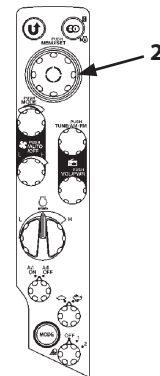

MDCD-01-026

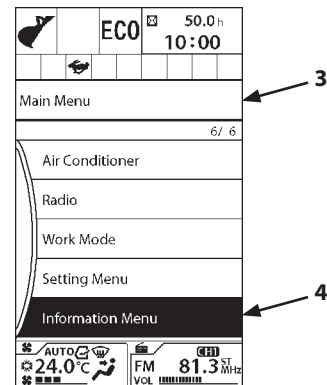

MDAA-01-190EN

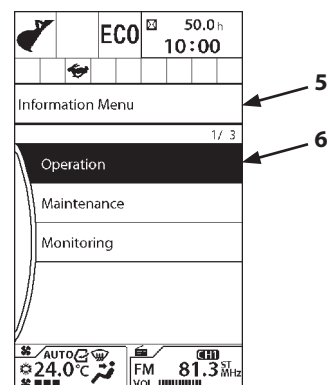

MDAA-01-191EN

## OPERATOR'S STATION

5. Push selector knob (2) to display Operation screen (7).

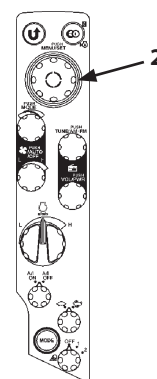

MDCD-01-026

6. Rotate selector knob (2) to highlight Fuel Consumption (8).

7. Push selector knob (2) to display Fuel Consumption screen (9).

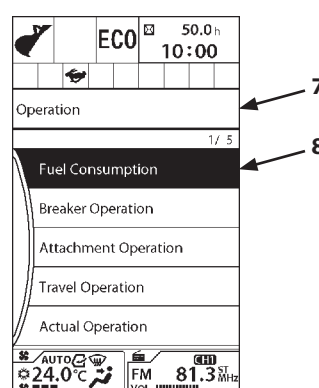

MDAA-01-193EN

The Machine Operation Hours, Fuel consumption, and Average Fuel Consumption rate can be checked on this screen.

Pushing selector knob (2) returns to the previous screen. To clear the Fuel Consumption and Machine Operation Hours, rotate selector knob (2) to highlight CLEAR (10), and then push selector knob (2).

**IMPORTANT: Total fuel consumption and fuel consumption rate depend on the operating environment and the operation method of the machine.**

**The values shown on the screen are just for reference.**

**A difference could arise between actual fuel consumption and fuel consumption as displayed on the monitor unit.**

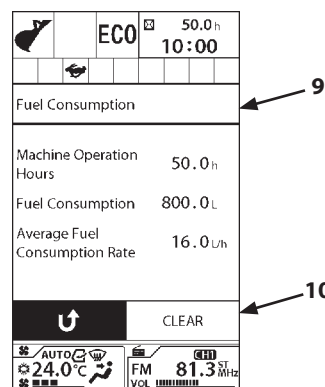

MDAA-01-194EN

## OPERATOR'S STATION

### Breaker Operation

1. Push selector knob (2) while displaying Basic Screen (1) to display Main Menu screen (3).
2. Rotate selector knob (2) to highlight Information Menu (4).
3. Push selector knob (2) to display Information Menu screen (5).
4. Rotate selector knob (2) to highlight Operation (6).

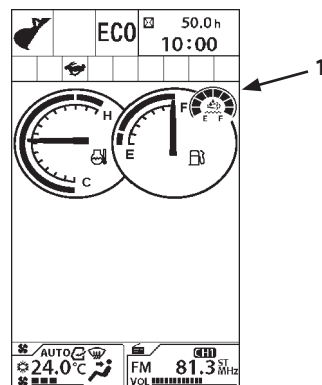

MDC1-01-001

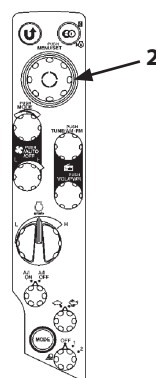

MDCD-01-026

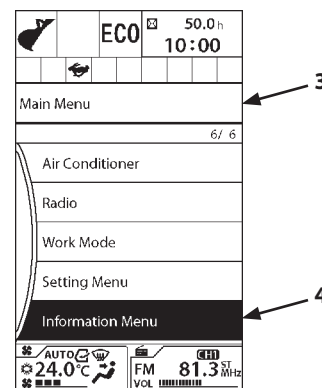

MDAA-01-190EN

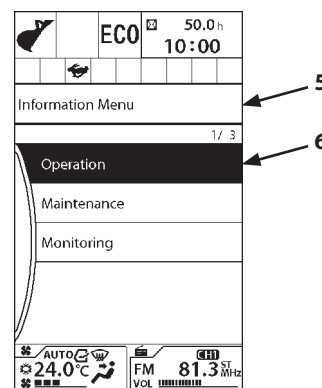

MDAA-01-191EN

## OPERATOR'S STATION

5. Push selector knob (2) to display Operation screen (7).

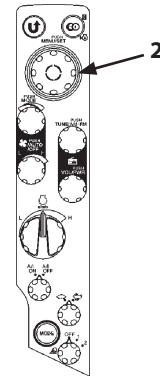

MDCD-01-026

6. Rotate selector knob (2) to highlight Breaker Operation (8).

7. Push selector knob (2) to display Breaker Operation screen (9).

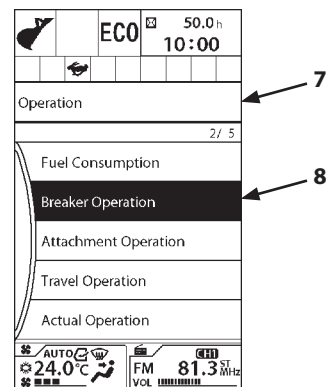

MDAA-01-196EN

Operating Time, Machine Operation Hours and Operation Ratio can be checked in this screen.

Pushing selector knob (2) returns to the previous screen.

To clear the Operation Time and Machine Operation Hours data, rotate selector knob (2) to highlight CLEAR (10), and then push selector knob (2).

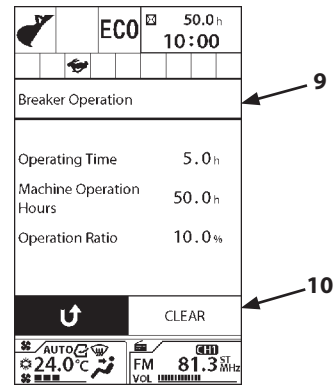

MDAA-01-197EN

## OPERATOR'S STATION

### Attachment Operation

1. Push selector knob (2) while displaying Basic Screen (1) to display Main Menu screen (3).
2. Rotate selector knob (2) to highlight Information Menu (4).
3. Push selector knob (2) to display Information Menu screen (5).
4. Rotate selector knob (2) to highlight Operation (6).

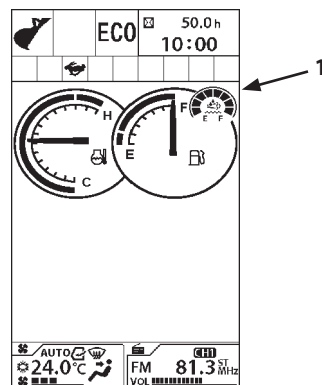

MDC1-01-001

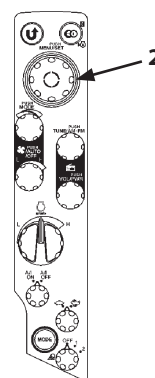

MDCD-01-026

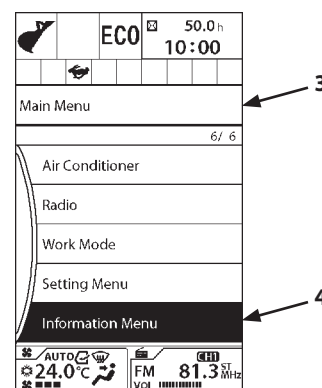

MDAA-01-190EN

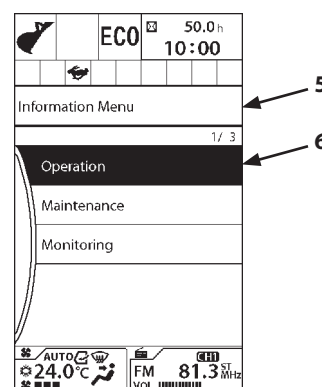

MDAA-01-191EN

## OPERATOR'S STATION

5. Push selector knob (2) to display Operation screen (7).

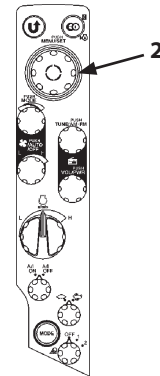

MDCD-01-026

6. Rotate selector knob (2) to highlight Attachment Operation (8).

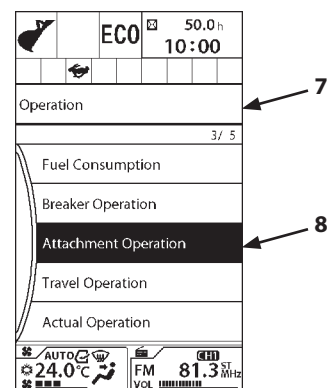

MDAA-01-199EN

7. Push selector knob (2) to display Attachment Operation screen (9).

The attachment Operating Time can be checked in this screen.

Push selector knob (2) to return to the previous screen. To clear the Operating Time data, rotate selector knob (2) to highlight CLEAR (10), and then push selector knob (2).

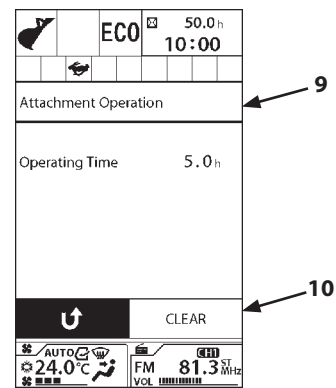

MDAA-01-200EN

## OPERATOR'S STATION

### Travel Operation

1. Push selector knob (2) while displaying Basic Screen (1) to display Main Menu screen (3).
2. Rotate selector knob (2) to highlight Information Menu (4).
3. Push selector knob (2) to display Information Menu screen (5).
4. Rotate selector knob (2) to highlight Operation (6).

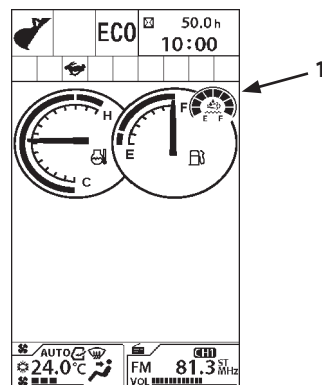

MDC1-01-001

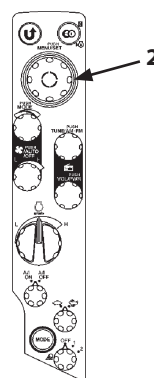

MDCD-01-026

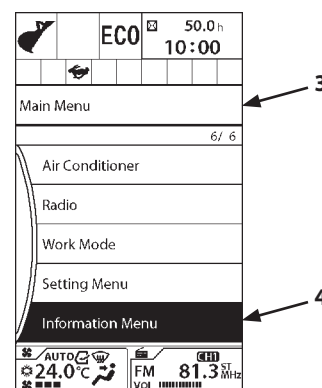

MDAA-01-190EN

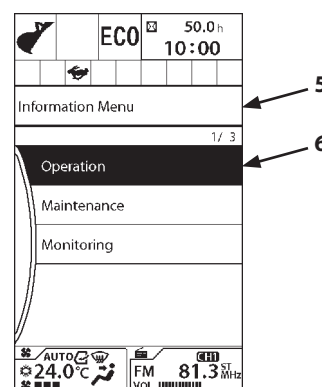

MDAA-01-191EN

## OPERATOR'S STATION

5. Push selector knob (2) to display Operation screen (7).

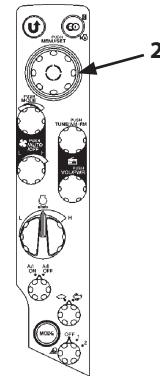

MDCD-01-026

6. Rotate selector knob (2) to highlight Travel Operation (8).

7. Push selector knob (2) to display Travel Operation screen (9).

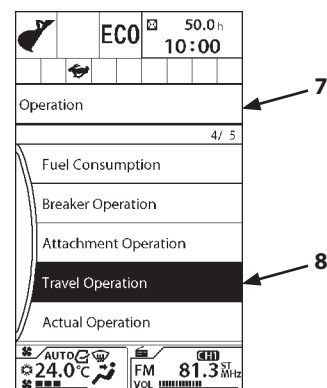

MDAA-01-202EN

Total Travel Operating Time can be checked in this screen. Push selector knob (2) to return to the previous screen. To clear the Operating Time data, rotate selector knob (2) to highlight CLEAR (10), and then push selector knob (2).

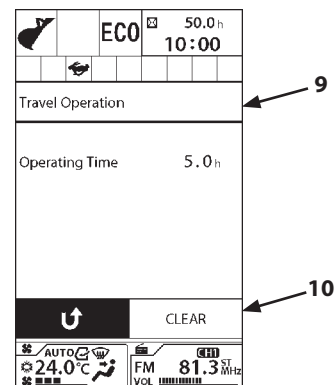

MDAA-01-203EN



## OPERATOR'S STATION

### Actual operation

1. Push selector knob (2) while displaying Basic Screen (1) to display Main Menu screen (3).
2. Rotate selector knob (2) to highlight Information Menu (4).
3. Push selector knob (2) to display Information Menu screen (5).
4. Rotate selector knob (2) to highlight Operation (6).

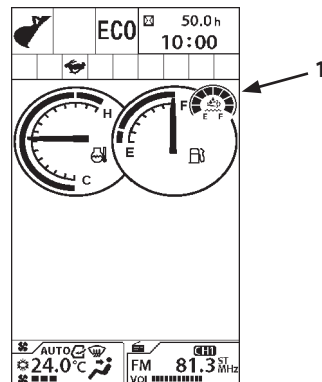

MDC1-01-001

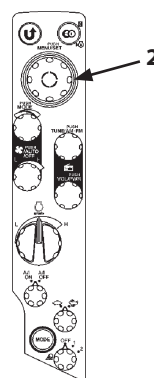

MDCD-01-026

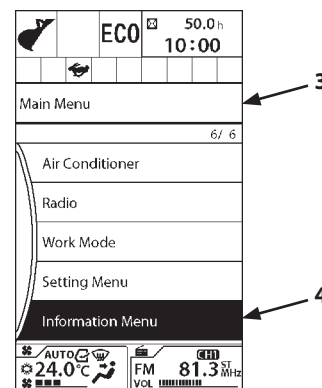

MDAA-01-190EN

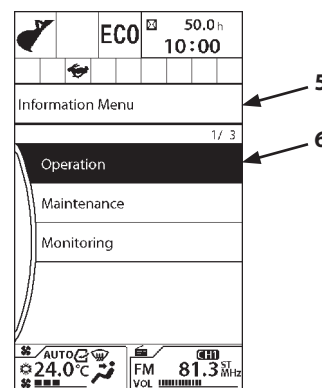

MDAA-01-191EN

## OPERATOR'S STATION

5. Push selector knob (2) to display Operation screen (7).

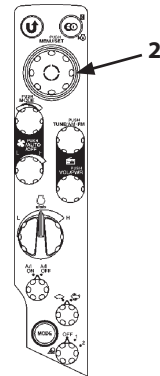

MDCD-01-026

- 6. Rotate selector knob (2) to highlight Actual Operation (8).
- 7. Push selector knob (2) to display Actual Operation screen (9).

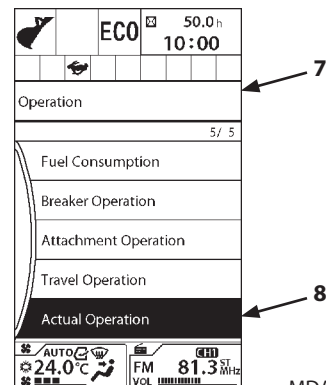

MDAA-01-205EN

The actual Operating Time can be checked in this screen. Push selector knob (2) to return to the previous screen. To clear the Operating Time data, rotate selector knob (2) to highlight CLEAR (10), and then push selector knob (2).

 **NOTE:** The Operating Time includes travel operation hours as well as all other operations.

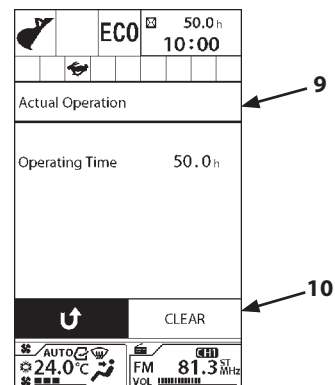

MDAA-01-206EN

# OPERATOR'S STATION

## Maintenance

The maintenance screen includes maintenance notice, remaining hours until the next maintenance, and maintenance intervals.

### Maintenance Items

- Engine Oil
- Engine Oil Filter
- Hydraulic Oil
- Hydraulic Oil Pilot Filter
- Hydraulic Oil Full-Flow Filter
- Pump Transmission Oil (Only ZX225USLC-6, 345USLC-6)
- Travel Device Oil
- Swing Device Oil
- Swing Bearing Grease
- Air Cleaner Filter
- Fuel Filter
- Air Conditioner Filter
- DEF/AdBlue® Supply Module Main Filter
- Oil Separator Element (Only ZX135US-6)
- Fuel Solenoid Pump Filter\*
- User Setting 1
- User Setting 2

 **NOTE:** Item with \*mark: Refer to "Maintenance" section.

### Maintenance Notice

1. Push selector knob (2) while displaying Basic Screen (1) to display Main Menu screen (3).
2. Rotate selector knob (2) to highlight Information Menu (4).
3. Push selector knob (2) to display Information Menu screen (5).
4. Rotate selector knob (2) to highlight Maintenance (6).

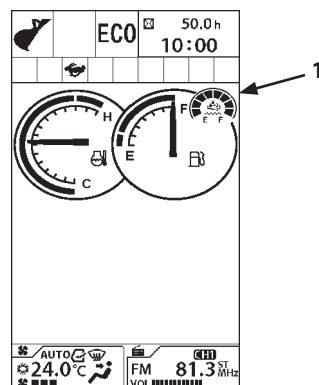

MDC1-01-001

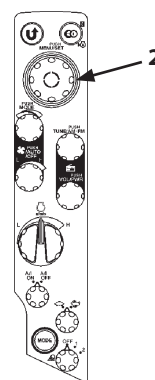

MDCD-01-026

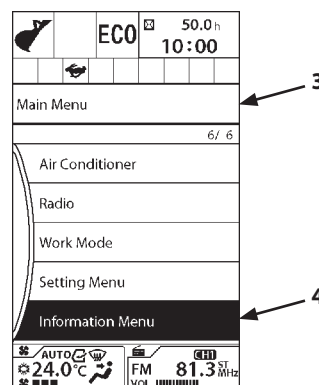

MDAA-01-190EN

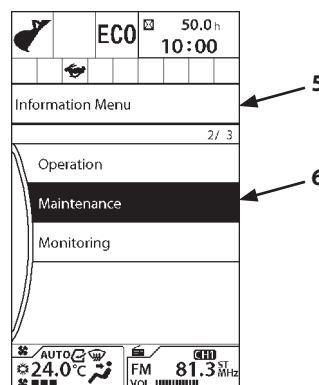

MDAA-01-223EN

## OPERATOR'S STATION

5. Push selector knob (2) to display Maintenance screen (7).

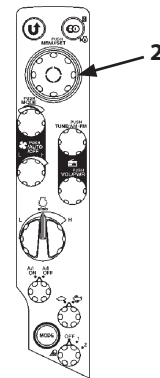

MDCD-01-026

6. Rotate selector knob (2) to highlight Maintenance Notice (8).

7. Push selector knob (2) to turn the Maintenance Notice ON. Push selector knob (2) again to turn the Maintenance Notice OFF.

ON : When the required interval is reached, an information message is displayed on the screen.  
 OFF : No notification message is displayed.

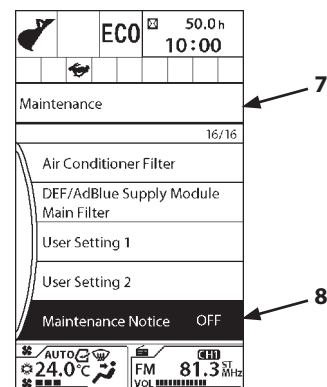

MDAT-01-208EN

 **NOTE:** When the required interval for an item is reached, screen (9) is displayed for 10 seconds when the key is switched ON. Push Return to Previous Screen switch to delete the notification. When checking the maintenance items from the menu, items where the set time has been reached are marked with a spanner (10).

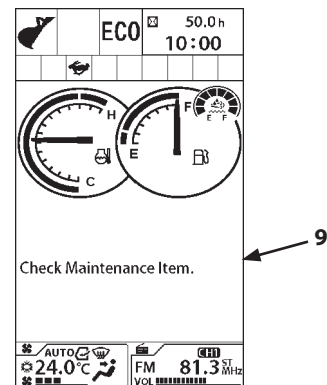

MDC1-01-213EN

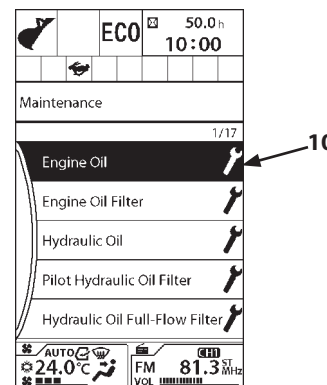

MDAA-01-214EN

# OPERATOR'S STATION

## Remaining Time and Maintenance Interval

1. Push selector knob (2) while displaying Basic Screen (1) to display Main Menu screen (3).
2. Rotate selector knob (2) to highlight Information Menu (4).
3. Push selector knob (2) to display Information Menu screen (5).
4. Rotate selector knob (2) to highlight Maintenance (6).

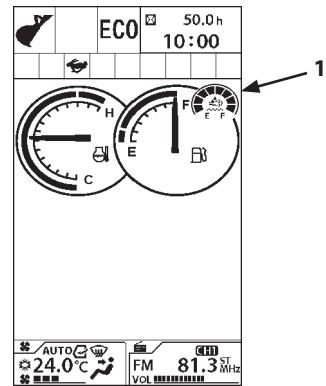

MDC1-01-001

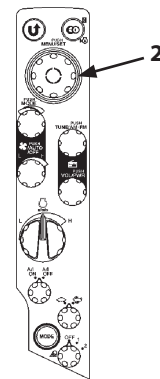

MDCD-01-026

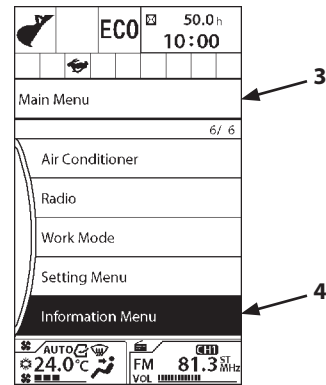

MDAA-01-190EN

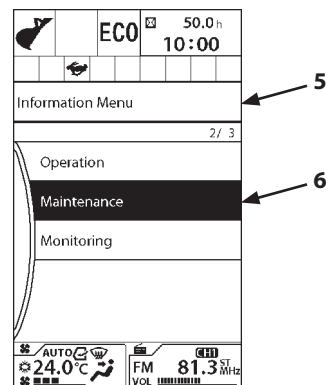

MDAA-01-223EN

## OPERATOR'S STATION

5. Push selector knob (2) to display Maintenance screen (7).

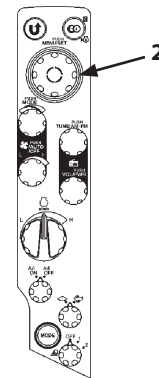

MDCD-01-026

6. Rotate selector knob (2) to highlight a Maintenance Item to be checked (8). (In the example on the right, Engine Oil is selected.)

7. Push selector knob (2) to display the time remaining for the selected maintenance item.

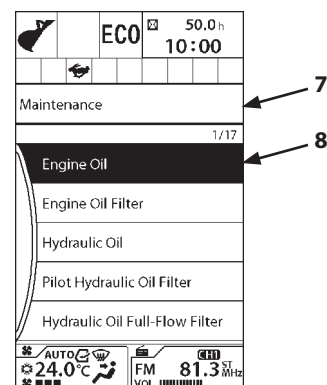

MDAA-01-336EN

### Resetting Data

To reset the remaining time data, rotate selector knob (2) to highlight RESET (9), and then push selector knob (2).

The value of the remaining hours is reset to that of the change interval. The previous change date/hour is updated with the current date and time.

### Maintenance Interval Setting

To change the maintenance interval, rotate selector knob (2) to highlight  (11), and then push selector knob (2).

The background color of Maintenance Interval (10) changes, then rotate selector knob (2) to adjust the time, and then push selector knob (2) to enable the change.

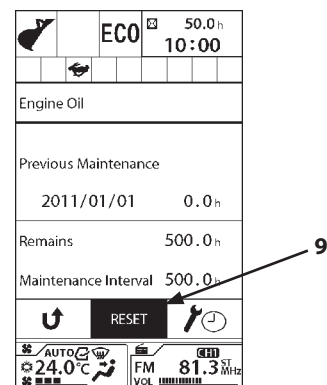

MDAA-01-210EN

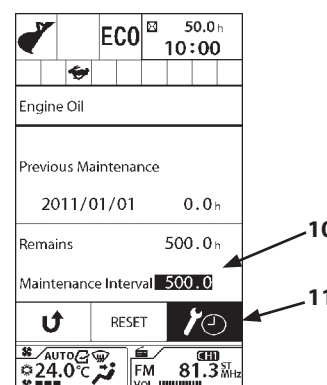

MDAA-01-212EN

# OPERATOR'S STATION

## Monitoring

The engine speed can be checked.

1. Push selector knob (2) while displaying Basic Screen (1) to display Main Menu screen (3).
2. Rotate selector knob (2) to highlight Information Menu (4).
3. Push selector knob (2) to display Information Menu screen (5).
4. Rotate selector knob (2) to highlight Monitoring (6).

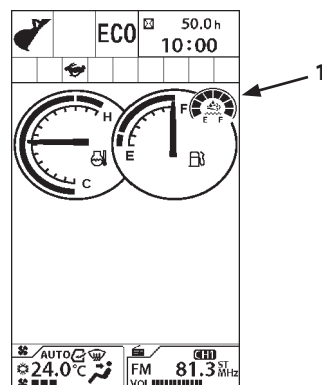

MDC1-01-001

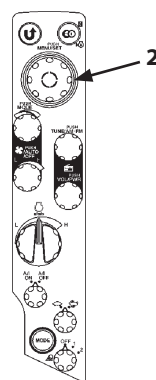

MDCD-01-026

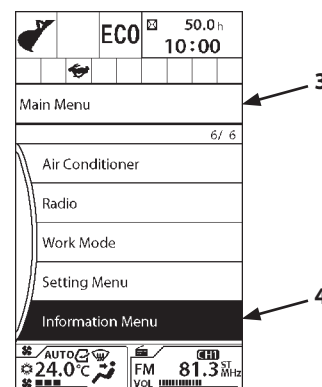

MDAA-01-190EN

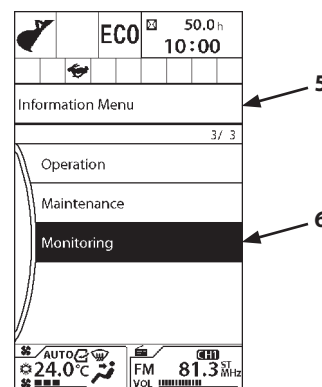

MDAA-01-220EN

# OPERATOR'S STATION

5. Push selector knob (2) to display Monitoring screen (7).

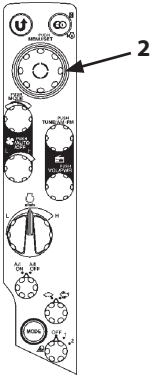

MDCD-01-026

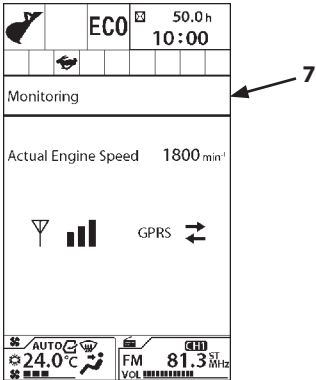

MDC1-01-221EN



## OPERATOR'S STATION

### Switch Panel

- 1- Return to Previous Screen Switch
- 2- Return to Basic Screen Switch
- 3- Selector Knob
- 4- Temperature Control Switch/Mode Switch
- 5- AUTO/OFF Switch/Fan Switch
- 6- AM/FM Selector/Tuning Switch
- 7- Power Switch/Volume Control Knob
- 8- Engine Control Dial
- 9- Auto-Idle Switch
- 10- Travel Mode Switch
- 11- Power Mode Switch
- 12- Work Light Switch
- 13- Wiper/Washer Switch
- 14- Numeric Keypad

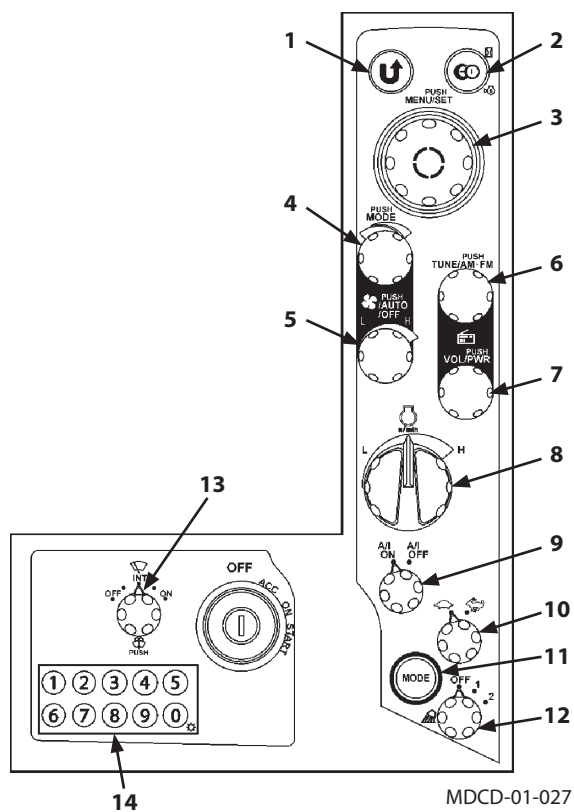

## OPERATOR'S STATION

---

### Return to Previous Screen Switch (Monitor)

Push this switch to return to the previous screen.



MDAA-01-010

### Return to Basic Screen Switch (Monitor)

Allows any screen to return to the basic screen.



MDAA-01-011

### Selector Knob (Monitor)

Push : Push this switch while the basic screen is displayed, the menu screen opens.

Push this switch after the menu screen, the action is confirmed.

Rotate : Cursor moves.

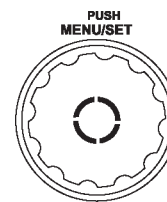

MDAA-01-012

### Temperature Control Switch/Mode Switch (Air Conditioner)

Push : Air vent is selected.

Rotate : Sets the temperature.

TEMP/MODE

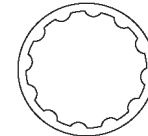

MDAA-01-013

### AUTO/OFF Switch/Fan Switch (Air Conditioner)

Push : Push this switch while the air conditioner is OFF, and it turns to AUTO. Push this switch while operating the air conditioner, and it turns OFF.

Rotate : Adjusts the blower speed.



MDAA-01-015

## OPERATOR'S STATION

### AM/FM Selector/Tuning Switch (Radio)

Push : AM/FM is selected.

Rotate : Adjusts radio frequency.

PUSH  
TUNE/AM,FM

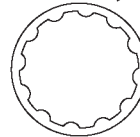

MDAA-01-014

### Power Switch/Volume Control Knob (Radio)

Push : Turns power ON/OFF.

Rotate : Adjusts the volume.

PUSH  
VOL/PWR

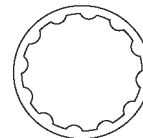

MDAA-01-016

### Engine Control Dial

Use engine control dial (1) to adjust engine speed.

The fully clockwise position : Fast Idle

Counterclockwise : Slow Idle

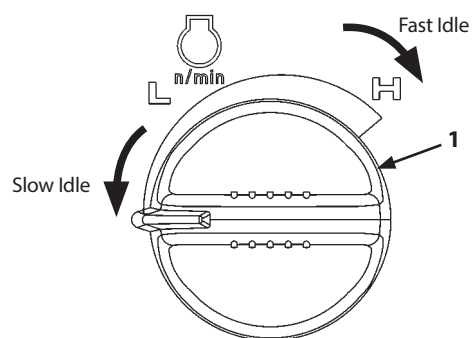

M1P1-01-068

## OPERATOR'S STATION

### Auto-Idle Switch

Auto-idle switch (2) sets the engine speed control mode to either Auto-Idle ON or OFF.

- Auto-Idle Speed

When auto-idle switch (2) is turned to ON position, the engine speed decreases to the idle after approximately 4 seconds at the state in which the control lever is turned to neutral.

This function saves fuel consumption.

When the auto-idle mode is selected, auto-idle indicator (3) on the monitor panel lights.

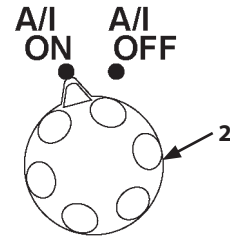

MDAA-01-017

 **NOTE:**

- Auto-idle control may not work completely until the end of the warm-up.
- The auto-idle control function does not operate when the aftertreatment device is regenerating.

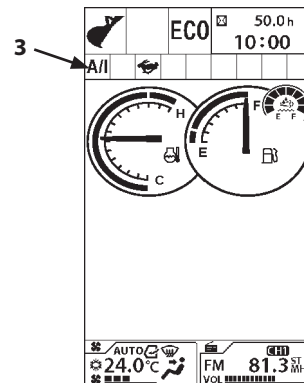

MDC1-01-314

### Travel Mode Switch

Two travel modes, FAST and SLOW, are selected by turning the travel mode switch to either position.

 Mark (Fast Speed Mode)

 Mark (Slow Speed Mode)

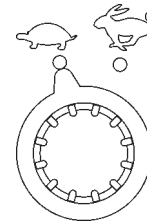

MDCD-01-028

## OPERATOR'S STATION

### Power Mode Switch

The three engine speed modes, ECO, PWR or H/P mode are selected by operating the power mode switch.

- **ECO (Economy) Mode**  
Operate the machine in this mode when performing normal work.  
ECO is displayed on Power Mode Display (1).
- **PWR (Power) Mode**  
Use PWR (Power) mode when extra horsepower is needed.  
PWR is displayed on Power Mode Display (1).
- **H/P (High Power) Mode**  
Use the H/P mode when extra fast speed and/or heavy duty work is needed.

 **NOTE:** ECO mode is set automatically when starting the engine. Set PWR mode if necessary.



MDAA-01-274

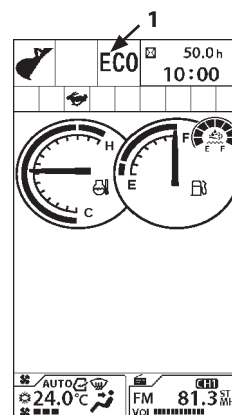

MDC1-01-001

### Work Light Switch

Work light switch has the following positions.

- 1 Position : Work light (3) on the base machine will light. Also, the switch panel illumination will light.
  - 2 Position : Work light (4) mounted on the boom and work light (3) on the right side of the machine will light. At the same time, the switch panel illumination will light. The monitor changes to night mode.
- OFF : Work lights (3), (4), and the switch panel illumination will turn off.

 **NOTE:** When the key switch is turned OFF while the work light switch is in 2-position, work light (4) turns ON for 30 seconds.

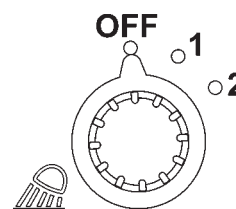

MDCD-01-029

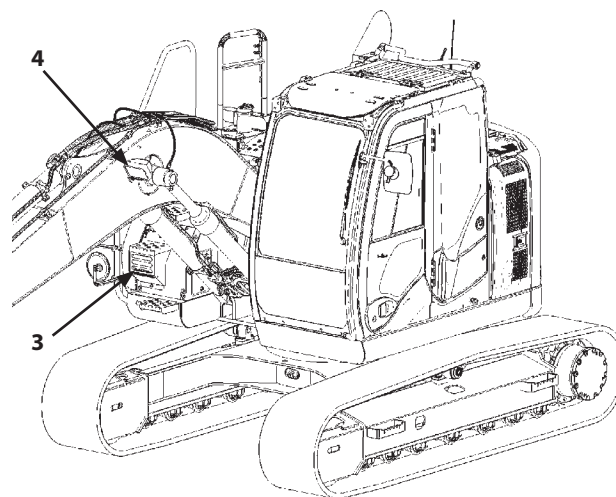

MDAT-01-270

## OPERATOR'S STATION

### Wiper/Washer Switch

The wiper and the window washer are operated using the wiper/washer switch.

- **Wiper**  
Turn the wiper/washer switch to the specified position to operate the wiper.

OFF	The wiper stops and is retracted.
INT Position	The wiper operates intermittently at the interval selected by the switch position as described below. INT mode has three positions of operating speed as shown below.
INT (Slow):	The wiper operates at 8-second interval.
INT (Mid):	The wiper operates at 6-second interval.
INT (Fast):	The wiper operates at 3-second interval.
ON	The wiper operates continuously.

 **NOTE:** When the front window (upper) is opened, the wiper and washer will not operate. If the front window is opened while operating the wiper, the wiper stops.

- **Washer**  
Push and hold the wiper/washer switch to squirt washer fluid onto the front window. When the wiper/washer switch is pressed for more than 2 seconds, the wiper operates until the switch is released. When the wiper/washer switch is released, the wiper automatically retracts.  
When operating the wiper in INT mode, while push and hold the wiper/washer switch, the wiper operates continuously.

 **NOTE:** The wiper motor protection control stops wiper operation, to prevent it from becoming stuck when operated for long period of time under high load. When the wiper stops, do not change the arm position and wait several minutes until the wiper starts operation again.

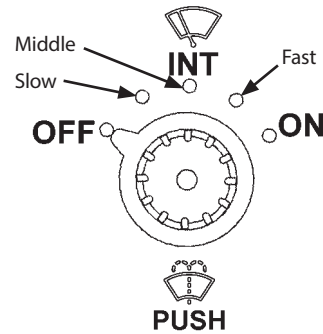

MBFM-01-005

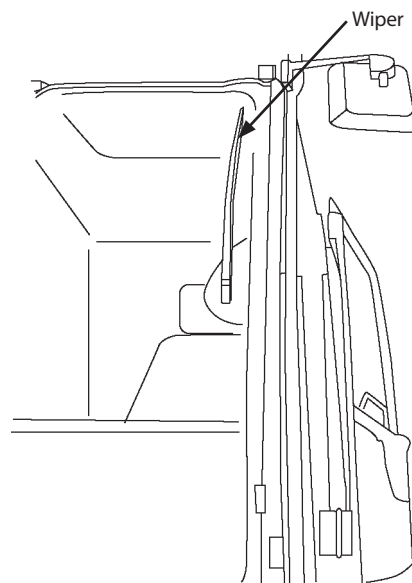

MDC1-01-513

## OPERATOR'S STATION

### USB Power Supply Port

#### Using the USB Power Supply Port

The USB power supply Port (2) can be used to power or charge mobile devices or electrical equipment.

#### IMPORTANT:

- The USB power supply Port (2) of this vehicle supplies DC 5V.
- Its maximum rated capacity is 5V/2A.  
If a device that exceeds the maximum capacity is plugged in, the protective function will be actuated, which may prevent use/charging of the device.
- The type of USB terminals that can be used are A-type.  
If a different type of terminal is used, it may fail to operate or charge, or may cause damage.
- The only function is power output, and it cannot be used for data transfer, communication etc.
- Some devices require a special cable. In such case, use the special cable.
- Do not use for a long time with the engine stopped. Doing so may discharge the batteries.
- Remove the connected device promptly after it is charged.
- It is not waterproof, so do not get any liquids, such as water on it.
- Note that warranty repairs do not cover damage to a connected device, or loss or corruption of data.
- Do not connect damaged devices. Smoke and/or fire may result.
- Never insert metal or foreign objects into the USB terminals. Electrical shock and/or damage may result.
- Be careful of connected cables. Tripping on them may result in falling down and getting hurt, or damage to the device.

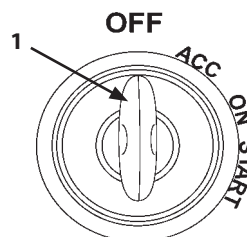

MDC1-01-502

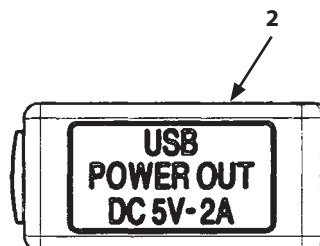

MDD5-01-013

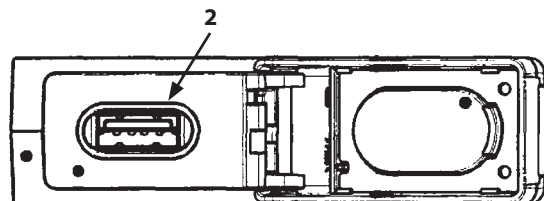

MDD5-01-014

## OPERATOR'S STATION

1. Open the cap to the USB power supply Port (2).
2. Insert the USB terminal of your device.
3. Turn key switch (1) to the ACC or ON position. This allows the USB power supply to be used.
4. After use, disconnect your device from the USB terminal and close the cap of the USB power supply Port.

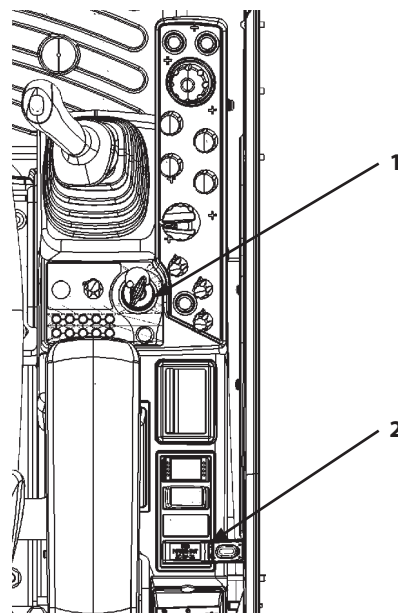

MDC1-01-571

### Numeric Keypad

Used for inputting password.

Push the numeric keypad of 1 to 8 while the radio is ON, the radio station will switch to memorized channel of 1 to 8.

When the light is turned ON, the monitor changes to night mode screen.

Even if the light is turned ON, you can activate the daytime screen by pushing "0" on the numeric keypad.

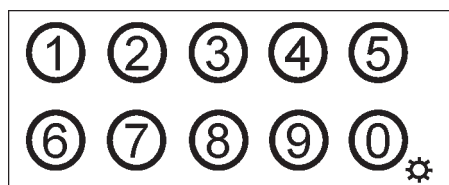

MDAA-01-018



## OPERATOR'S STATION

### Switch Panel (for Optional Equipments)

 **NOTE:** The optional switch locations differ, depending on the kinds of optional devices that the machine is equipped with. Before using the switches, confirm which types of optional devices the machine is equipped with. Raise the armrest when operating the optional switch. All available optional devices are shown below.

- Travel Alarm Deactivation
- Seat Heater
- Electrical Control
- Rear Light
- Perimeter Lights (Option)

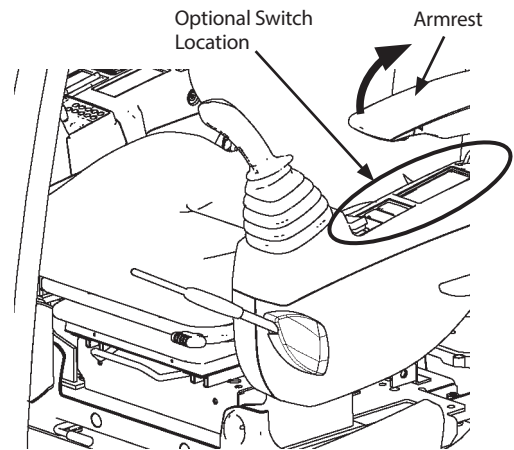

MDAA-01-327

## OPERATOR'S STATION

### Travel Alarm Deactivation Switch (Optional)

The travel alarm buzzer sounds during travel operation. When pushing the  mark of travel alarm deactivation switch (1), the travel alarm buzzer function is deactivated.

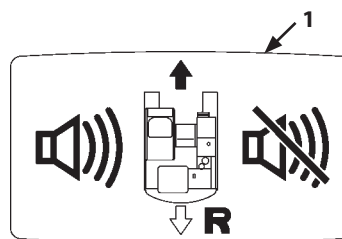

M1U1-01-035

### Rear Light Switch

When rear light switch (2) is turned ON, the rear light at the rear of the cab roof comes ON.

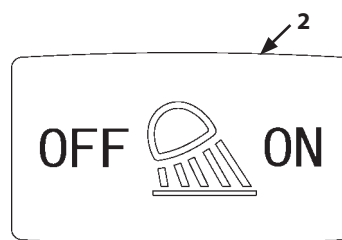

MDC1-01-501

### Perimeter Lights Switch (Optional)

Pressing perimeter lights switch (3) to the ON side turns on the lights (4) on the left, right and rear of the machine. Perimeter lights and a rear light cannot be mounted at the same time.

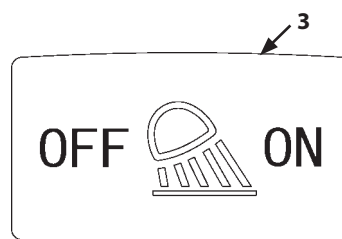

MDC1-01-501

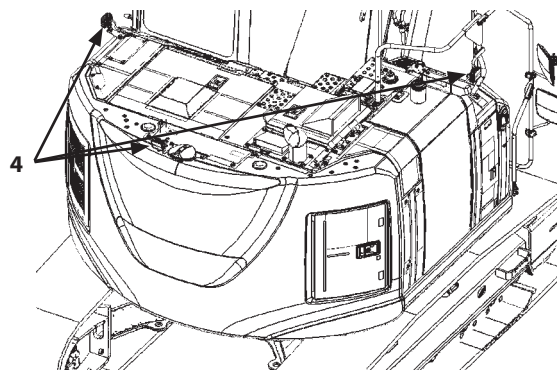

MDAT-01-269

## OPERATOR'S STATION

---

### Seat Heater Switch (Optional)

When seat heater switch (5) is turned ON, the seat and/or backrest are heated to warm them up. When the temperature of the seat and/or backrest reaches its specified temperature, heating turns off automatically.



M1U1-01-011

### WARNING:

- **Use with seat wet or something poking into seat could cause electrical shock.**
  - **Be careful when handling water or drinking water.**
  - **Do not use if clothes are extremely wet.**
  - **Do not poke the seat with a sharp object or put anything heavy with protruding parts on the seat.**

### CAUTION:

- **Certain person as noted below, could be at risk of a low temperature burn, so should be careful during use.**
  - **Person with delicate skin**
  - **Person suffering from fatigue**
  - **Person under excessive drinking or medication that could cause sleepiness (sleeping pills, cold medicines, etc.)**
- **Continuous use could cause low temperature burn to person.**
- **Use with blanket or cushion which may retain heat could cause abnormal heating of the seat.**

### IMPORTANT:

- **To prevent damage, do not poke the seat with sharp objects or put anything heavy with protruding parts on the seat.**
- **If a liquid like water or a drink is spilled on the seat, wipe off with a soft cloth and make sure the seat is dry before using again.**
- **If the seat is abnormally hot, stop use and contact your authorized dealer.**

 **NOTE:** *The point where heated varies with the type of seat.*

## OPERATOR'S STATION

---

### Electrical Control Main Switch

By placing the pilot control shut-off lever in the lock release position, and pressing electrical control main switch (8), indicator (9) lights, allowing use of the electrical control (attachment switch). Pressing electrical control main switch (8) one more time, turns indicator (9) to the OFF position. Also by turning the key switch to the OFF position changes the indicator OFF.

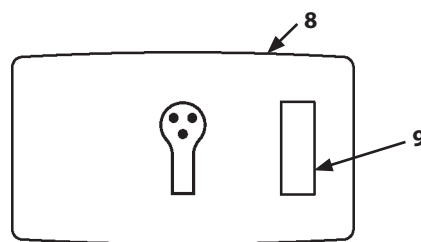

MDAA-01-311

**⚠ CAUTION:** When there is no need to use the electrical control (attachment switch) system, turn OFF electrical control main switch (8) to avoid incorrect operation.

## OPERATOR'S STATION

### Key Switch

- 1- OFF (Engine Off)
- 2- ACC (Horn, Radio etc.)
- 3- ON (Engine ON)
- 4- START (Engine Start)

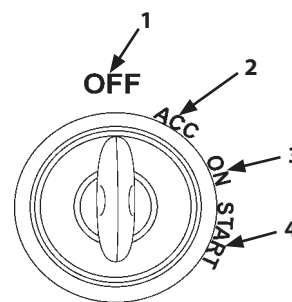

MDC1-01-502

### Power Boost Switch

Power boost switch (5) is provided on the top of the right control lever.

While pressing power boost switch (5), the maximum digging power is boosted within approximately 8 seconds to increase work capacity.

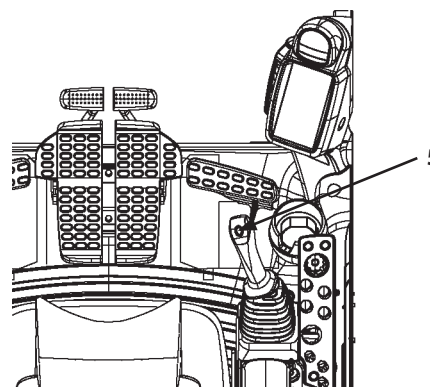

MDAA-01-292

### Horn Switch

Horn switch (6) is provided on the top of the left control lever. The horn sounds continuously as long as switch (6) is pressed.

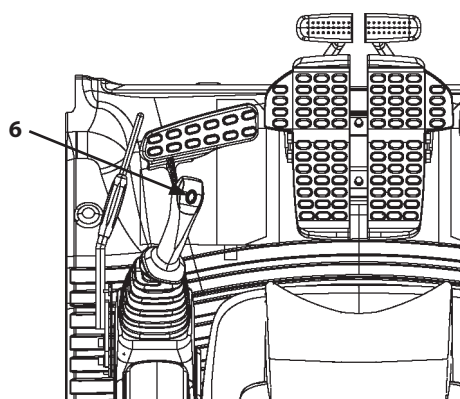

MDAA-01-293

## OPERATOR'S STATION

---

### Electrical Control Main Switch

- Attachment Switch (Assist Operation) (Main Operation)  
This switch (1) is mainly used for optional devices and attachments with a rotary or a tilt function. By placing the pilot control shut-off lever in the lock release position, and pressing electrical control main switch (1), indicator (2) will light. When indicator (2) is lit, operation of the attachment is possible.

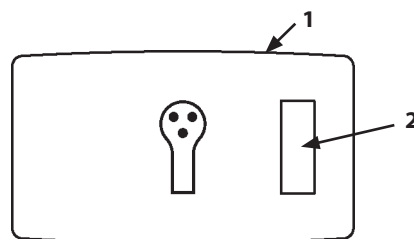

MDAA-01-311

**IMPORTANT: The attachment switch is operable only when indicator (2) of electrical control main switch (1) is lit. Indicator (2) will not light unless the pilot control shut-off lever is in the UNLOCK position.**

## OPERATOR'S STATION

---

### AUX Function Lever 1

1. Auxiliary
2. Power Boost Switch
3. Attachment Switch (Assist Operation) (Main Operation)
4. Auxiliary
5. Horn Switch
6. Auxiliary

### CAUTION:

- **These switches are provided for operating attachments of this machine. Hitachi does not bear responsibility on any human injury, malfunction and/or physical loss or damage incurred by unauthorized application or use of unauthorized attachments, optional parts or modified switch, which will void Hitachi Warranty Policy.**
- **Before using this switch, thoroughly read the operation manual of the corresponding attachment and check the operation of each function in a safe area.**
- **Before operating an attachment with this switch, confirm the requirements on safe and proper mounting and operation of the attachment with its manufacturer or distributor and observe them.**

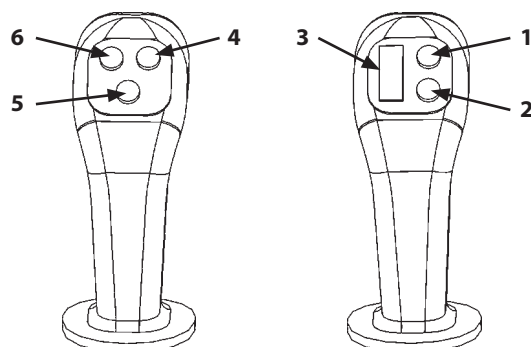

Left Control Lever

Right Control Lever

MDAA-01-337

MCGB-01-030

## OPERATOR'S STATION

### Cigar Lighter

#### Using Cigar Lighter

**IMPORTANT:** In case the cigar lighter does not pop out automatically 30 seconds after pushing the cigar lighter in, pull out the cigar lighter manually. Consult your authorized dealer.

1. Insert key switch (1). Turn it to "ACC" or "ON" position.
2. Push and release the cigar lighter knob.
3. The cigar lighter knob will return to the original position when the lighter becomes usable. Pull the cigar lighter out to use.
4. After use, reinsert the cigar lighter to its original position in the panel.

**CAUTION:** Do not power anything other than a genuine Hitachi Construction Machinery electrical device from the cigar lighter port.

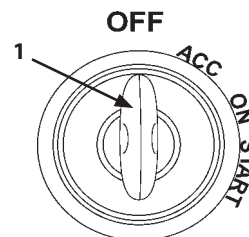

MDC1-01-502

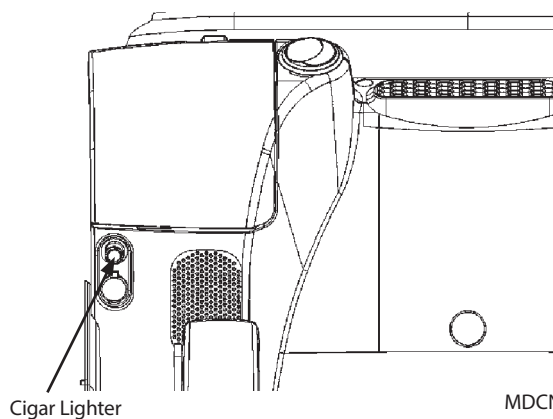

MDCN-01-006



# OPERATOR'S STATION

## Cab Light Switch

Push switch (1) on the cab light to turn the cab light ON.

- ON : The cab light comes and stays ON.  
(The light does not turn ON while the key OFF.)
- OFF : The cab light goes OFF.
- Door : The cab light turns ON as the cab door is opened.  
The cab light automatically goes off after 30 seconds.  
(The cab light turns ON while the key switch is OFF.)

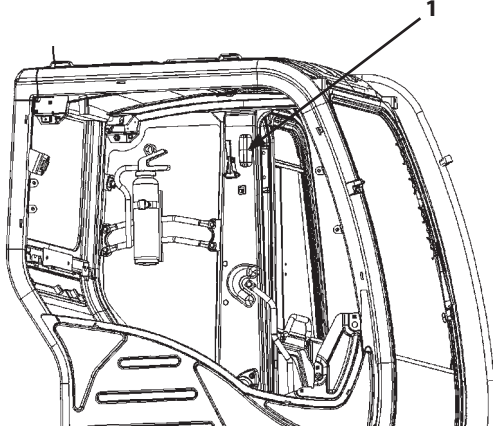

MDCN-01-007

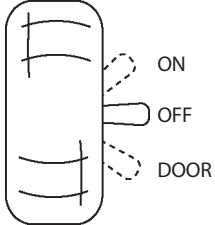

MCGB-01-023

## OPERATOR'S STATION

### Pilot Control Shut-Off Lever

Pilot control shut-off lever (1) functions to prevent the machine from being mistakenly operated when the operator accidentally touches the control lever or pedals when getting on or off the machine.

#### **⚠ WARNING:**

- Always pull pilot control shut-off lever (1) into the full LOCK position. Unless pilot control shut-off lever (1) is fully moved to the LOCK position, the control lever is not locked, possibly creating a hazardous situation.
- When leaving the machine, always stop the engine. Then, pull pilot control shut-off lever (1) up to the LOCK position.
- Always pull pilot control shut-off lever (1) up to the LOCK position before transporting the machine and leaving the machine.
- Confirm that pilot control shut-off lever (1) is in the LOCK position before starting the engine. The engine will not start in any position other than the LOCK position.

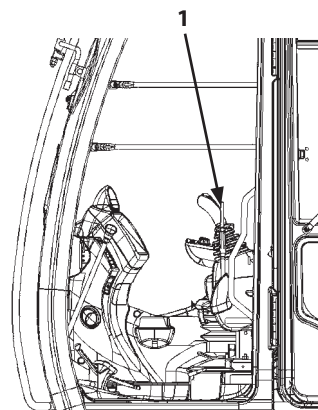

LOCK position

MDCN-01-008

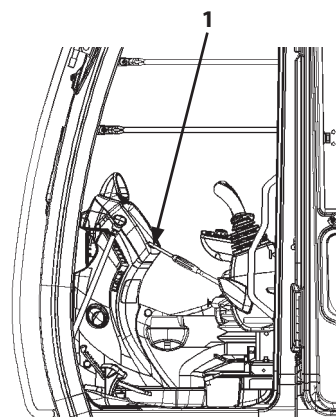

UNLOCK position

MDCN-01-009

## OPERATOR'S STATION

### Control Lever Auto-Lock

This function keeps the machine from operating to prevent it from moving contrary to the intention of the operator, in cases like inadvertently unlocking pilot control shut-off lever (1) when a control lever is engaged, such as by snagging a piece of clothing.

#### **! WARNING:**

- **The control lever auto-lock function is designed to inhibit unintentional operation of the machine and does not stop the machine in every situation.**
- **When moving the machine, make sure all the control levers are in neutral and then unlock pilot control shut-off lever (1).**

When this function is activated, the front, swing, travel and attachment controls are automatically locked, icon (2) on the monitor lights as illustrated and the buzzer sounds. Once this function is activated, the machine cannot be moved, even if a control lever is operated with pilot control shut-off lever (1) still in the UNLOCK position. To resume operation of the machine, return pilot control shut-off lever (1) to its LOCK position, make sure control levers are in neutral and then put the pilot control shut-off lever in its UNLOCK position.

#### **! WARNING:**

- **The control lever auto-lock function does not guarantee a full stop of the machine; in some circumstances, the vehicle may move somewhat before stopping after the function is activated.**
- **The time it takes to stop varies with hydraulic oil temperature. The colder the oil, the longer it takes to stop, so warm up the machine fully when it is cold.**
- **This function does not operate below a certain temperature when the hydraulic oil is cold. Icon (2) flashes on the monitor in conditions in which this function will not operate.**
- **When a pilot hose is disconnected, this function may not operate normally as system response deteriorates due to the effect of the air. Warm the machine fully after connecting hoses and air bleed the pilot circuit. Refer to "Bleeding Air from the Hydraulic System" on page 7-70 for information on this procedure.**

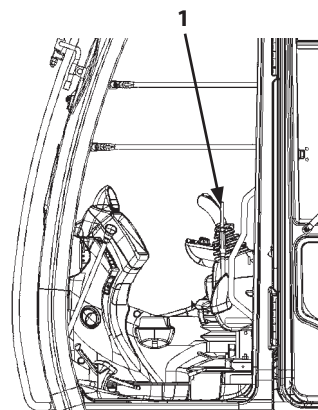

LOCK position

MDCN-01-008

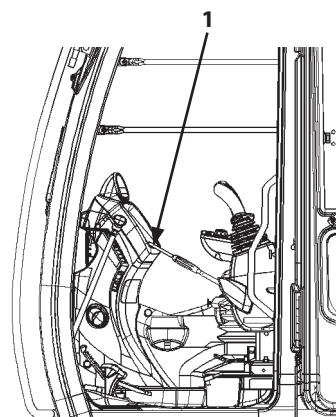

UNLOCK position

MDCN-01-009

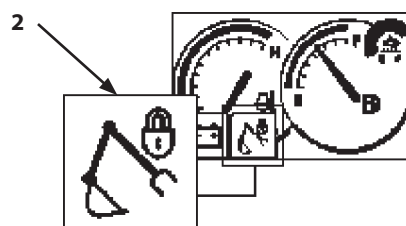

Warning Icon

MDC1-01-583

## OPERATOR'S STATION

---

### Engine Stop Switch

In case the engine does not stop even if the key switch is turned OFF due to failure of the machine, move switch (2) located at the front-left side of the seat stand downward to stop the engine.

After operating switch (2), be sure to return switch (2) back to the upward position.

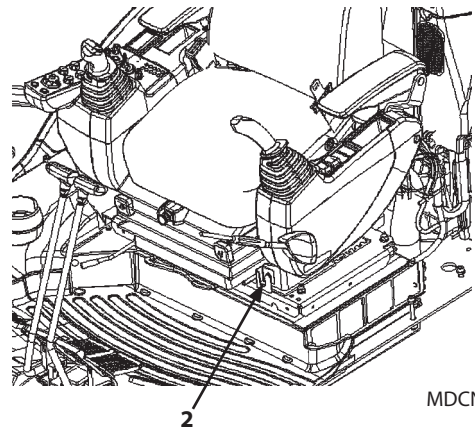

MDCN-01-004

## OPERATOR'S STATION

### Fuse Box

#### A

10- CONTROLLER 5 A	20- OPT.3 (ALT) 5 A
9- BACKUP 10 A	19- HORN 10 A
8- ECU 30 A	18- IDLE STOP 5 A
7- START 5 A	17- POWER ON 5 A
6- OPT.2 (ALT) 20 A	16- GLOW RELAY 5 A
5- OPT.1 (ALT) 5 A	15- AUX 10 A
4- SOLENOID 20 A	14- MONITOR 5 A
3- HEATER 20 A	13- LIGHTER 10 A
2- WIPER 10 A	12- RADIO 5 A
1- LAMP 20 A	11- FUEL PUMP 5 A

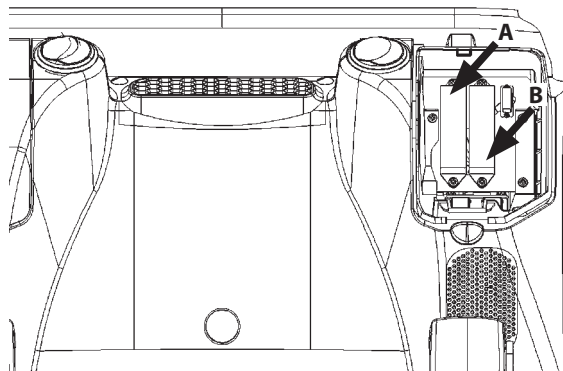

MDCN-01-010

#### A

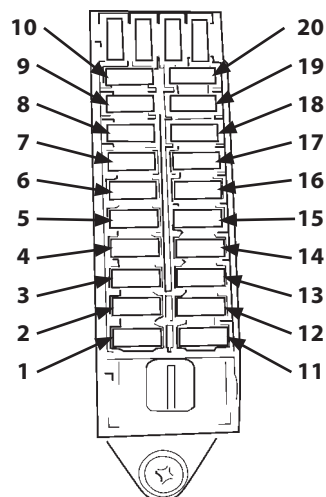

M1GR-01-003

#### B

30- -	40- -
29- -	39- -
28- SENSOR_UNIT 10 A	38- -
27- AUX.3 5 A	37- -
26- QUICK HITCH 5 A	36- -
25- IMMOBI 5 A	35- DCU 20 A
24- 12VUNIT 10 A	34- AUX.2 10 A
23- CAB LAMP REAR 10 A	33- WARNING LAMP 10 A
22- CAB LAMP FRONT 10 A	32- CAB LAMP FRONT +2 10 A
21- SEAT HEATER 10 A	31- SEAT COMPR. 10 A

#### B

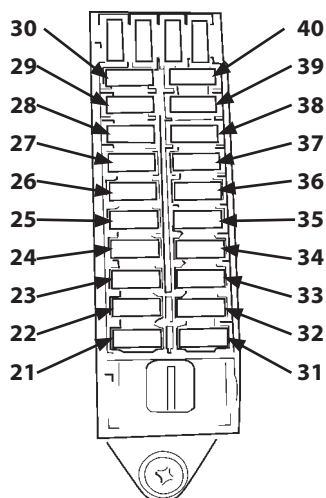

M1GR-01-003

## OPERATOR'S STATION

---

### Auto Air Conditioner

#### Features:

- Full Auto-Temperature Control:  
Automatically controls the air temperature in the cab to maintain the temperature set by the temperature control switch regardless of outside air temperature and intensity of the sun.
- Max. Cooling and Heating:  
Maximum cooling or heating can be obtained by rotating the temperature control switch clockwise (32 °C) or counterclockwise (18 °C) respectively.
- Heater Start-Operation Control System:  
In winter or in cold weather, when starting the engine, the engine coolant is cool and air temperature inside the cab is low. Until the coolant is warmed, when the front foot vent and/or foot vent is selected, the air flow level is fixed to the minimum setting and cool air is restricted from entering the cab.

 *NOTE: Even in summer, the high idle speed may be higher than the normal speed due to the above control system.*

## OPERATOR'S STATION

### Name of Components

- 1- Front Vent
- 2- Foot Vent
- 3- Defroster Vent
- 4- Rear Vent
- 5- Temperature Control Switch/Mode Switch
- 6- AUTO/OFF Switch/Fan Switch

 **NOTE:** Air flow direction can be adjusted by moving the louvers on all air vents except for foot vent (2). The louvers on front vents (1) and defroster vent (3) can be completely opened and closed by hand.

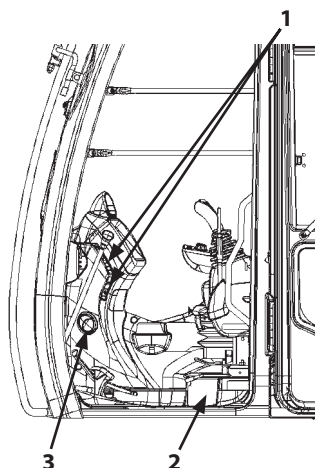

MDCN-01-008

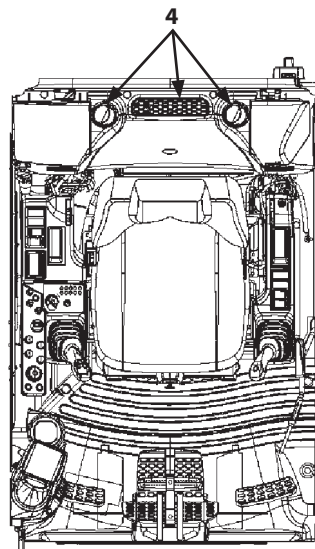

MDCN-01-003

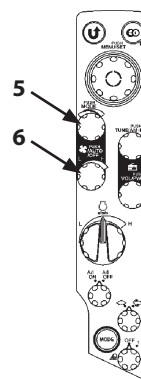

MDCD-01-026

# OPERATOR'S STATION

## Controller Part Name and Function

- Mode Switch (5)  
Selects the air vent. The selected air vent is indicated on monitor (7).

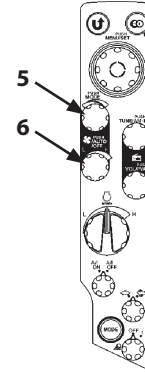

MDCD-01-026

### ZX135US-6

- Air flows out of the front and defroster vents.  
(Including defroster vent)
- Air flows out of the front, rear and defroster vents.  
(Including defroster vent)
- Air flows out of the front, rear, foot and defroster vents.  
(Including defroster vent)
- Air flows out of the foot vents.

### ZX225USLC-6, 345USLC-6

- Air flows out of the front and defroster vents.  
(Including defroster vent)
- Air flows out of the front, rear and defroster vents.  
(Including defroster vent)
- Air flows out of the front, rear, foot and defroster vents.  
(Including defroster vent)
- Air flows out of the foot vents.

Each time mode switch (5) is pressed, the vent mode can be changed in 4 stages as illustrated below.

### ZX135US-6



### ZX225USLC-6, 345USLC-6



- When switch (6) is selected in AUTO:  
The air vent mode is automatically selected.
- Temperature Control Switch (5):  
Sets the air temperature in the cab.  
Temperature in the cab can be set between 18.0 and 32.0 °C by rotating temperature control switch (5). Temperature can be set in 0.5 °C increments.  
The set-temperature is displayed on monitor (7).

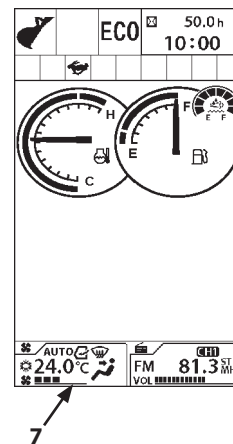

MDC1-01-001



## OPERATOR'S STATION

- Fan Switch (6)
  - When AUTO indicator (8) is ON, the blower speed is automatically controlled.
  - When AUTO indicator (8) is OFF, the blower speed is controlled in 6 steps. Rotate blower switch (6) clockwise to increase blower speed. Rotate blower switch (6) counterclockwise to decrease blower speed. Monitor (7) indicates the corresponding blower speed.
- AUTO/OFF Switch (6)

While the air conditioner is OFF, pressing AUTO/OFF Switch (6) switches the unit to AUTO mode. While operating the air conditioner, pressing AUTO/OFF switch (6) stops operation.

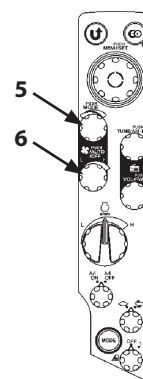

MDCD-01-026

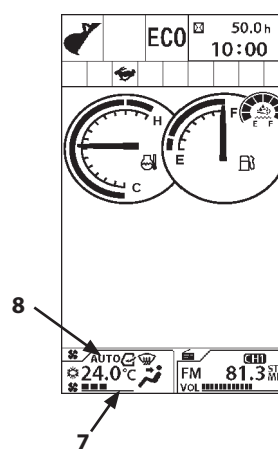

MDC1-01-001

## OPERATOR'S STATION

---

### Cab Heater Operation

1. AUTO/OFF switch (6):

According to signals sent from various sensors, the air conditioner amplifier automatically selects the air flow-in vents, air suction ports, and air flow-in temperature at the vent, and controls the blower speed.

2. Temperature Control Switch (5):

Adjust temperature control switch (5) so that "25.0" is indicated on the monitor. Control air temperature inside cab using switch (5) as necessary.

3. As Required:

- Operate Mode switch (5) to manually select the air vent.
- Operate Fan switch (6) to manually control the blower speed.
- Operate the air conditioner setting screen on the monitor to maintain the air vent in the fresh air mode or air circulation mode.

Usually the cab heater turns the dehumidifier function OFF, however, it can be turned ON by switching the A/C to ON at the air conditioner setting screen.

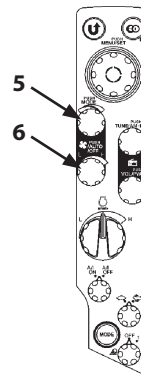

MDCD-01-026

## OPERATOR'S STATION

### Cooling Operation

1. AUTO/OFF switch (6):

Push AUTO/OFF switch (6) to set the air conditioner AUTO mode. According to signals sent from various sensors, the air conditioner amplifier automatically selects the air flow-in vents, air suction ports, and air flow-in temperature at the vent, and controls the blower speed.

2. Temperature Control Switch (5):

Adjust temperature control switch (5) so that "25.0" is indicated on the monitor. Control air temperature inside the cab using switch (5) as necessary.

3. As Required:

- Operate Mode switch (5) to manually select the air vent.
- Operate Fan switch (6) to manually control the blower speed.
- Operate the air conditioner setting screen on the monitor to maintain the air vent in the fresh air mode or air circulation mode.

If the front window (lower) becomes misty, manually close the defroster vent (3). (The vent can be closed manually.)

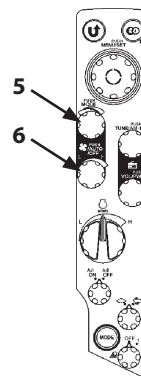

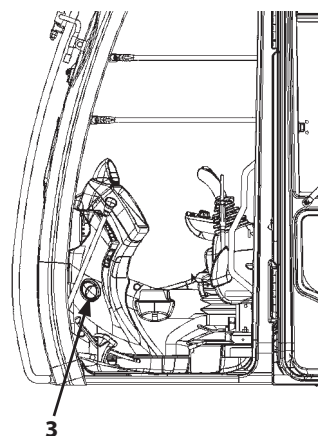

MDCD-01-026



MDCN-01-008

## OPERATOR'S STATION

### Defroster Operation

1. Push AUTO/OFF Switch (6) to blow out temperature-controlled air. When starting the engine during the cold season, the engine coolant temperature and air temperature in the cab are low. The Heater Start-Operation Control System controls the blow rate to the minimum (LO) in order to restrict cool air from flowing into the cab.
2. Adjust temperature control switch (5) so that "25.0" is indicated on the monitor. From the air conditioner setting screen on the monitor, set to fresh air mode.
3. Select the front vents  or the front and rear vents  using mode switch (5).

Control air flow direction by adjusting the louvers at front vent (1) and defroster vent (3).

Control air temperature in the cab by using temperature control switch (5).

If the windowpanes become misty during rainy season or in order to eliminate moisture, turn A/C ON at the air conditioner screen on the monitor.

### Cool Head/Warm Feet Operation

Cool and warm air is simultaneously supplied to the head vents and feet vents respectively.

#### ZX135US-6

1. Press blower switch (6) to adjust the blower speed.
2. Press MODE switch (5) to display the front and rear vent mark  on the monitor.  
Turn A/C ON from the air conditioner setting screen on the monitor.

#### ZX225USLC-6, 345USLC-6

1. Press blower switch (6) to adjust the blower speed.
2. Press MODE switch (5) to display the front and rear vent mark  on the monitor.  
Turn A/C ON from the air conditioner setting screen on the monitor.

Control air temperature inside the cab by using temperature control switch (5).

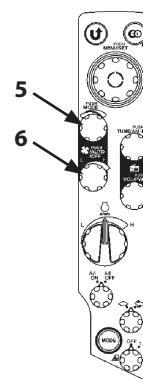

MDCD-01-026

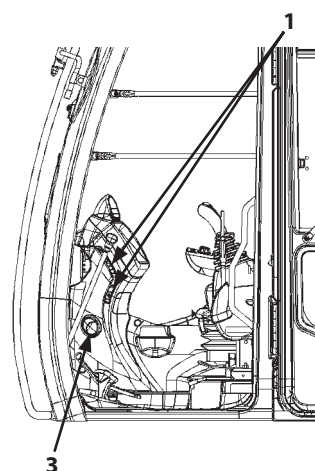

MDCN-01-008

## OPERATOR'S STATION

### Tips for Optimal Air Conditioner Usage

#### For Rapid Cooling

Temperature in the cab may rise over 80 °C (176 °F) when the machine is exposed to sun light in the summer. In this case, ventilate air in the cab first by opening the windows for rapid cooling.

After starting the engine, push AUTO/OFF switch (6). Set temperature to "18.0" on the monitor by using temperature control switch (5). Turn air circulation mode ON from air conditioner setting screen on the monitor.

Close the windows when the cab cools down to the ambient temperature.

Auto Air Conditioner Sensor

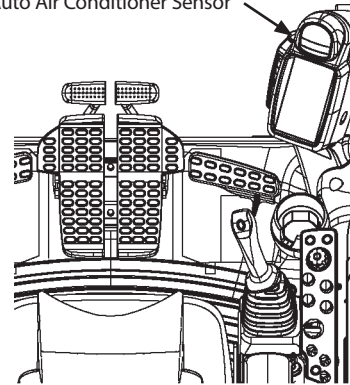

MDAA-01-292

#### When Windows Become Misty

If the insides of the windows become misty during rainy weather or on humid days, operate the air conditioner to aid in keeping the windows clear.

When the atmosphere is very damp, and if the air conditioner has run excessively, the outside of the windows may become misty. If this happens, turn off the air conditioner to adjust the temperature in the cab.

#### Off-Season Air Conditioner Maintenance

To protect each part of the compressor from a lack of lubricant, operate the air conditioner at least once a month for several minutes with the engine running at a slow speed during off-season.

#### IMPORTANT:

- Do not suddenly increase the engine speed. Failure to do so may damage the compressor.
- Refer to the item "Check Air Conditioner Filter" in the Maintenance Chapter for maintenance of the air conditioner filters.
- Always clean the auto air conditioner sensor for effective air conditioner performance. Avoid placing any obstructions around the sensor.

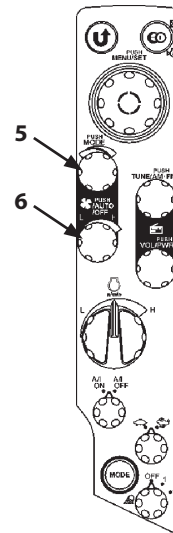

MDCD-01-026

# OPERATOR'S STATION

## AM/FM Radio Operation

**CAUTION:** Refrain from listening to the radio in the cab while operating the machine.

### Controls on the Radio

#### 1- AM/FM Selector/Tuning Switch

"FM" or "AM" is switched over alternately each time the switch is pressed. Rotate tuning switch (1) clockwise to increase frequency, counterclockwise to decrease frequency.

#### 2- Power Switch/Volume Control Knob

Push: Turns power ON/OFF. Rotate the volume control knob (2) clockwise to increase the sound volume. Rotate it counterclockwise to decrease the sound volume.

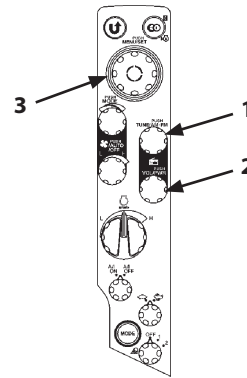

MDCD-01-026

### Tuning Procedure

#### • Manual Tuning Procedure

Rotate tuning switch (1) until the desired station is reached.

#### • Automatic Search Function

1. Push selector knob (3) while displaying Basic Screen (4) to display Main Menu screen (5).

2. Rotate selector knob (3) to highlight Radio (6).

Push selector knob (3) to display the Radio screen.

Rotate selector knob (3) to highlight Seek (8). Push selector knob (3) to go to the next higher frequency station. Push selector knob (3).

Rotate selector knob (3) to highlight seek (7). Push selector knob (3) to go to the next lower frequency station. Push selector knob (3).

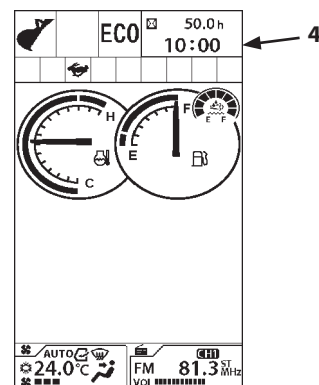

MDC1-01-001

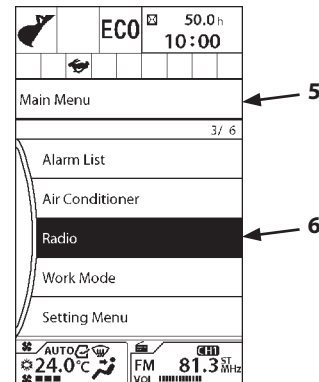

MDAA-01-092EN

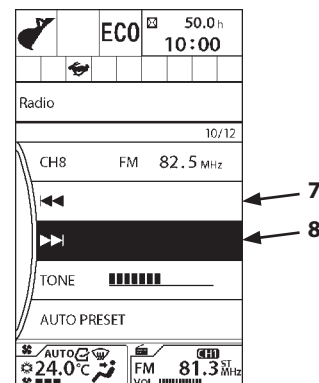

MDAA-01-095EN

# OPERATOR'S STATION

## Station Presetting Procedure

### Setting from Monitor

1. Select the desired station. Refer to the "Tuning Procedure" in the previous section.
2. Push selector knob (1) while displaying Basic Screen (2) to display Main Menu screen (3). Rotate selector knob (1) to highlight Radio (4).
3. Push selector knob (1) to display Radio screen (5).
4. Rotate selector knob (1) to highlight a CH to preset a station. (CH1 to CH8)
5. Push and hold selector knob (1) for more than 1 second. The current station is preset to the selected CH.

### Setting from numeric keypad

1. Select the desired station. Refer to the "Tuning Procedure" in the previous section.
2. Push and hold one keypad buttons (7) (1 to 8) for more than 1 second. The current station is preset to the selected number of CH.

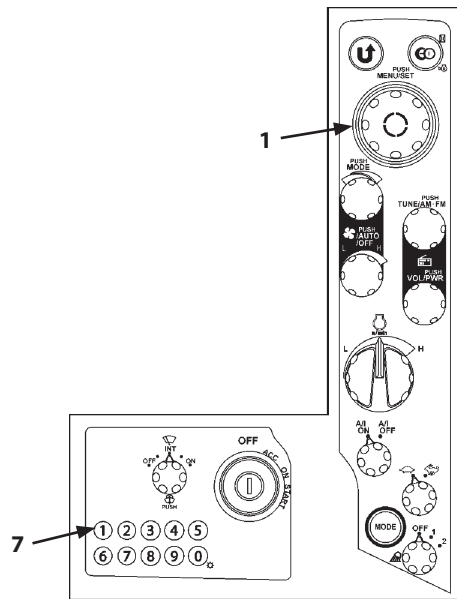

MDCD-01-027

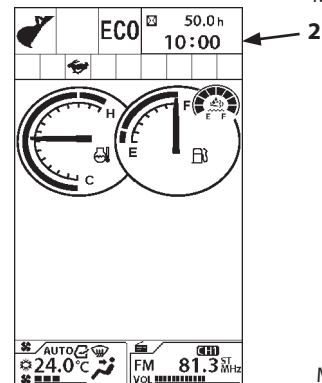

MDC1-01-001

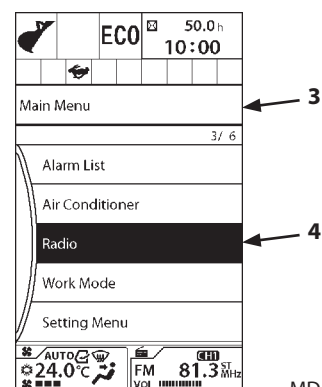

MDAA-01-092EN

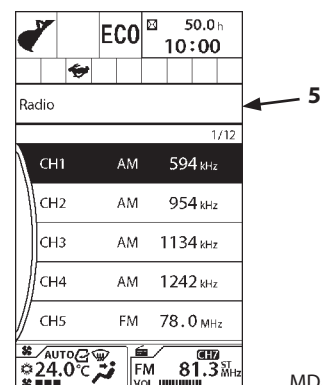

MDAA-01-093EN

## OPERATOR'S STATION

### Station Auto-Presetting Procedure

Receivable stations can be automatically detected and preset to the memory.

1. Push selector knob (1) while displaying Basic Screen (2) to display Main Menu screen (3).
2. Rotate selector knob (1) to highlight Radio (4).  
Push selector knob (1) to display Radio screen (5).
3. Rotate selector knob (1) to highlight AUTO PRESET (6).
4. Push selector knob (1) to start AUTO PRESET process.  
AUTO PRESET scans reception frequency, and allocates the stations with the strongest signal to CH1 to CH8.  
AM frequency stations will be preset from CH1 to CH4,  
FM frequency stations will be preset from CH5 to CH8.  
Operating the radio during scan stops the AUTO PRESET.

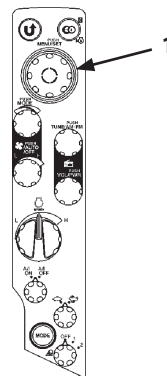

MDCD-01-026

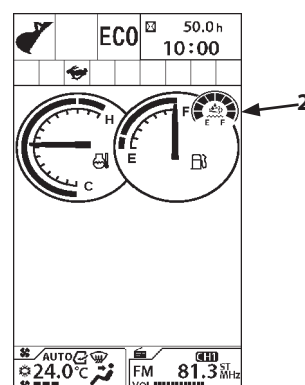

MDC1-01-001

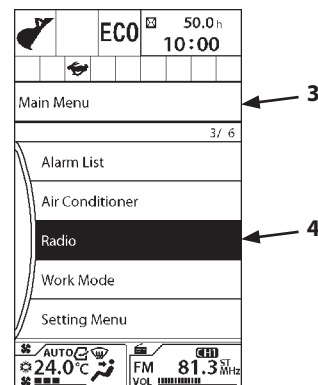

MDAA-01-092EN

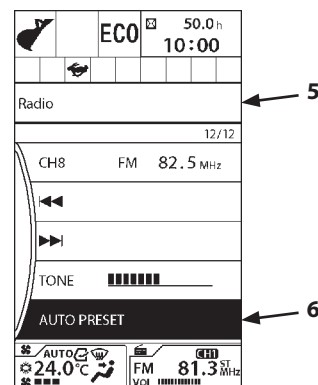

MDAA-01-099EN



# OPERATOR'S STATION

## TONE Control

1. Push selector knob (1) while displaying Basic Screen (3) to display Main Menu screen (4).
2. Rotate selector knob (1) to highlight Radio (5).  
Push selector knob (1) to display Radio screen (6).
3. Rotate selector knob (1) to highlight TONE (7).
4. Push selector knob (1) to adjust TONE control. Rotate selector knob (1) clockwise to boost treble. Rotate selector knob (1) counterclockwise to boost bass. Push selector knob (1) to enable the changes.

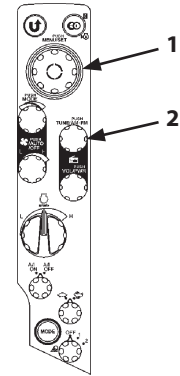

MDCD-01-026

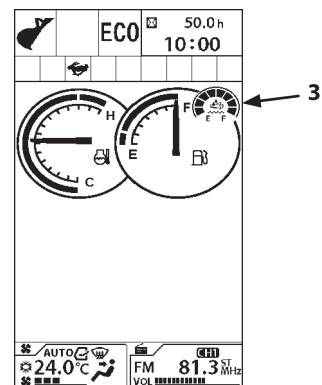

MDC1-01-001

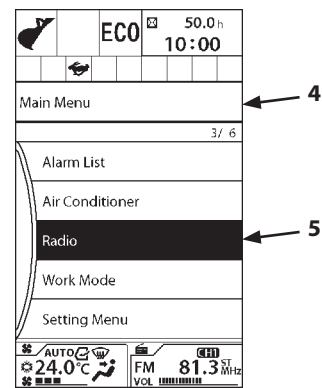

MDAA-01-092EN

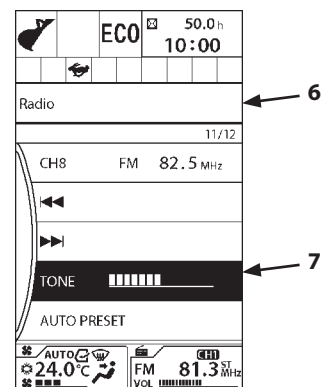

MDAA-01-096EN

## OPERATOR'S STATION

### Audio Input

**IMPORTANT:** This function is available only to a machine equipped with an audio input (Optional). Use this function with proper sound volume.

#### Audio Input Selection

Attach the audio input (Optional) device and push AM/FM Selector/Tuning Switch (1) to display AM and FM screen as well as AUX input screen (3).

#### Connecting audio device

By removing AUX IN Cap (4), the audio input terminal appears.

Connect your audio device to the audio input terminal of the machine with your audio cable.

#### IMPORTANT:

- Use  $\Phi 3.5$  mm stereo plug for the connection of audio input terminal.
- Put AUX IN cap (4) when the audio input is not in use.

#### Volume Control of audio device

Turn the volume down to the minimum beforehand, and then turn volume control knob (2) clockwise to adjust the volume.

#### IMPORTANT:

- If volume control knob (2) has been set to the maximum level the sound will be extremely loud. Set volume control knob (2) to the minimum first and then turn it clockwise to increase the volume. Adjust the volume control knob on the audio device if the sound is too low, even when the volume control knob (2) is set to the maximum level.
- Operate your audio device to play or stop the sound.

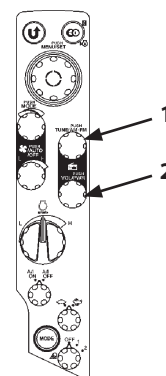

MDCD-01-026

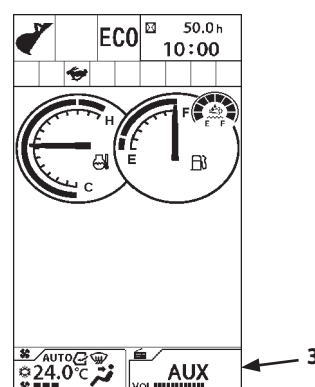

MDC1-01-340

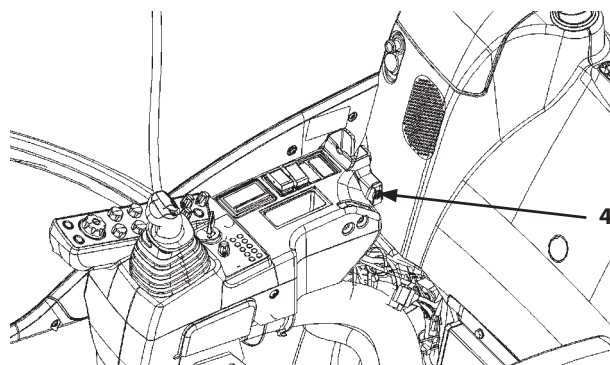

MDCN-01-011

## OPERATOR'S STATION

### Aerial Angle Monitor

A composite image of the area around the vehicle is displayed on main monitor (1) and consists of images from camera (4) on the right side, camera (5) on the left and camera (6) on the rear of the machine. It helps when checking for obstacles around the vehicle.

Pressing screen changeover switch (2) allows the camera image to be displayed as-is.

#### WARNING:

- **The images are displayed for the purpose of helping the operator check the area around the vehicle. People and objects displayed on the monitor may appear differently from their actual positions or distances. Some areas, such as near and under the vehicle, cannot be depicted by the cameras. Before moving the machine, always check the area around the machine thoroughly before moving it.**
- **Check visibility of the monitor image before operating the machine. If the visibility is poor, the field of vision cannot be ensured, which may result in serious personal injury or property damage.**
- **The installation position of cameras is adjusted to produce a good composite image. Do not make any alterations, such as changing the position of left (4), right (5) or rear (6) cameras.**
- **If the image is difficult to see, clean the camera(s) and/or monitor to make the image clearer. Always ensure good footing when cleaning the cameras.**

 NOTE: The surface of side camera monitor (1) and camera lenses are made of plastic. When cleaning them, use a clean, water-dampened cloth and wipe them gently. Never use an organic solvent.

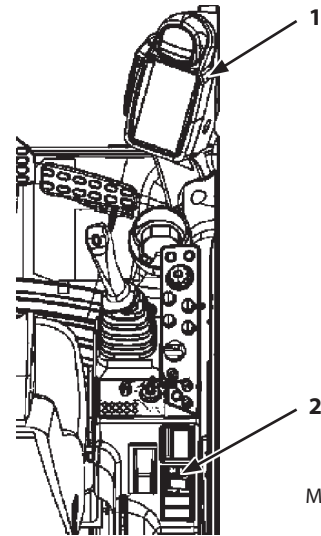

MDC1-01-573

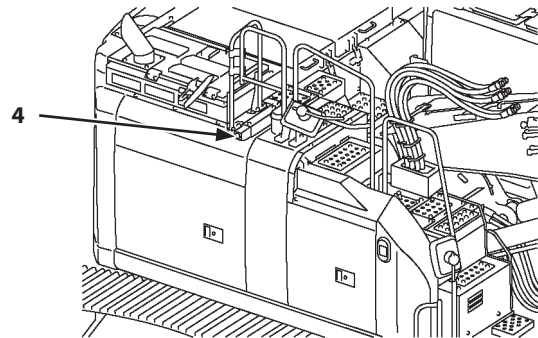

MDD5-01-002

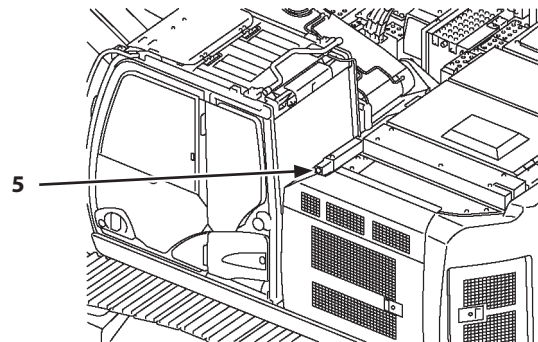

MDD5-01-003

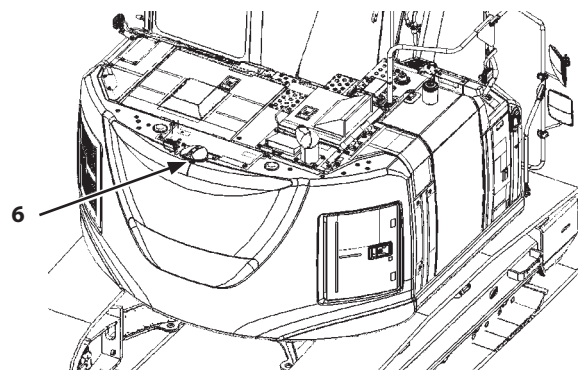

MDAT-01-269

## OPERATOR'S STATION

### IMPORTANT:

- When the door of the cab is fully open, the door appears in the image from left side camera (5). If the field of vision is insufficient, ensure visibility using the operator seat mirror.
- If there are any problems with the image on main monitor (1), consult your authorized dealer.
- It may be necessary to reconfigure the camera composition if work is done that affects camera installation position (such as removing/installing camera brackets, counterweights or replacing a camera). Make sure camera images are displayed properly via the inspection methods indicated in the section "Checking Aerial Angle Camera Images" on page 7-173. If any camera images are not displayed properly, contact your authorized dealer.

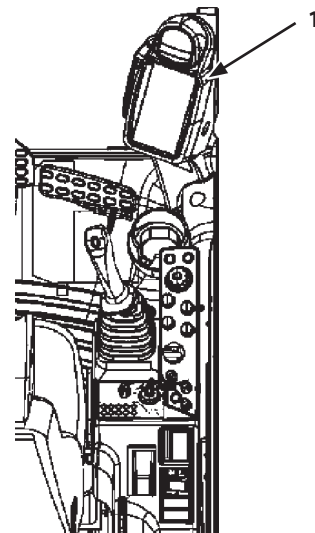

MDC1-01-573

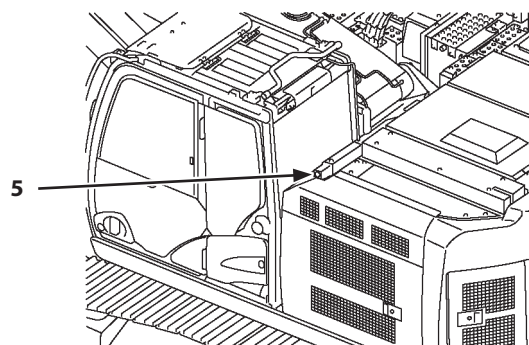

MDD5-01-003

# OPERATOR'S STATION

## Switching the Screen Display

Pressing screen changeover switch (1) changes the screen.

- Display Screen
  - Pressing the right side of the switch changes the screen in the → order.
  - Pressing the left side of the switch changes the screen in the ⇐ order.

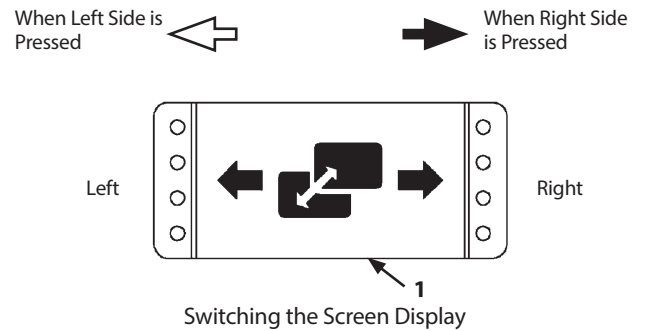

MDCK-OP3-002

1- Image Around Machine

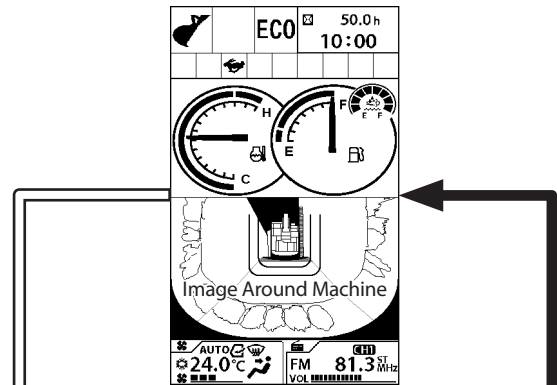

MDC1-01-590EN

2- Image Behind Machine + Image on Right of Machine

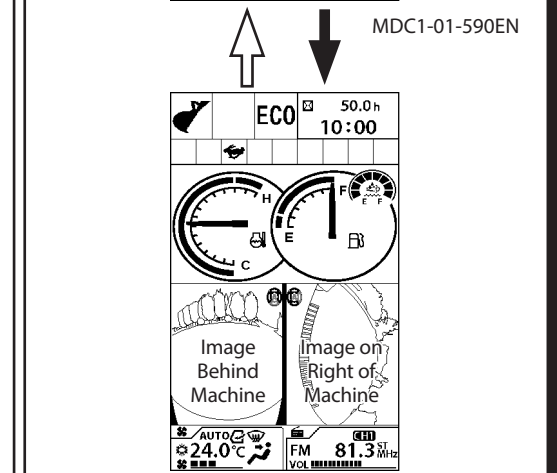

MDC1-01-591EN

3- Image Behind Machine + Image on Right + Image on Left of Machine

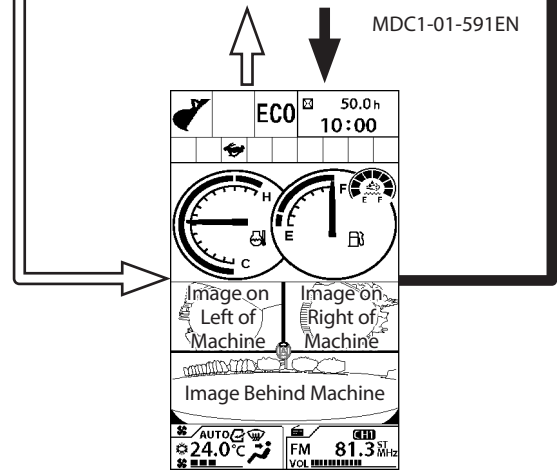

MDC1-01-592EN

## OPERATOR'S STATION

### Description of Images

#### Image Around Machine

The image around the machine is displayed full-screen. It is a composite of the images from the right, left and rear cameras.

Image processing is used to compress the images, so a wide area around the machine can be viewed, including areas that are in blind spots with a normal rearview mirror.

Objects on the right and left sides of the machine are combined from the 2 camera images, which may result in objects overlapping or parts of objects missing.

The square image in the center of the image (vehicle icon (1)) indicates the machine itself.

Guide lines (2) indicate distances from the machine.

The guide lines indicate positions 1 and 2 meters from the machine. They are a rough guide to the distance of obstacles.

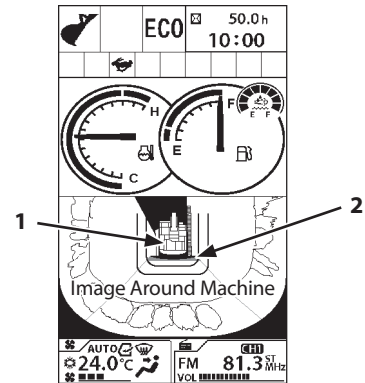

MDC1-01-590EN

#### **!** WARNING:

- **The image around the machine is compressed using image processing to allow a wide view at a glance, but care must be used as the sense of distance and how things appear are different from a normal, uncompressed image.**
- **As the image around the machine is processed and combined from multiple camera images, it may appear different from when looked at with the naked eye and areas may not appear contiguous, objects may appear to be collapsing or not appear in the image at all.**
- **A clear image may not be shown if the area around the machine is too bright or too dark.**
- **Guide lines are based on the ground being flat. The distances of guide lines are not accurate on sloping or rough terrain.**

## OPERATOR'S STATION

### Vehicle Icon

The vehicle icon is a bird's eye view of the vehicle from directly above it.

The vehicle icon on the monitor makes it possible to imagine the orientation of the vehicle and the position of the cab.

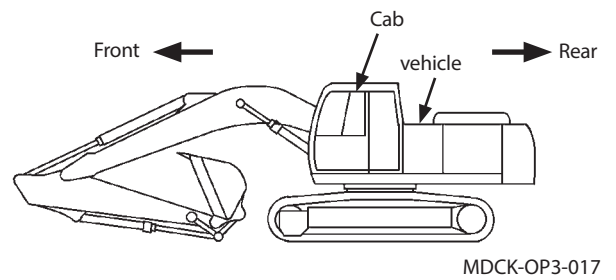
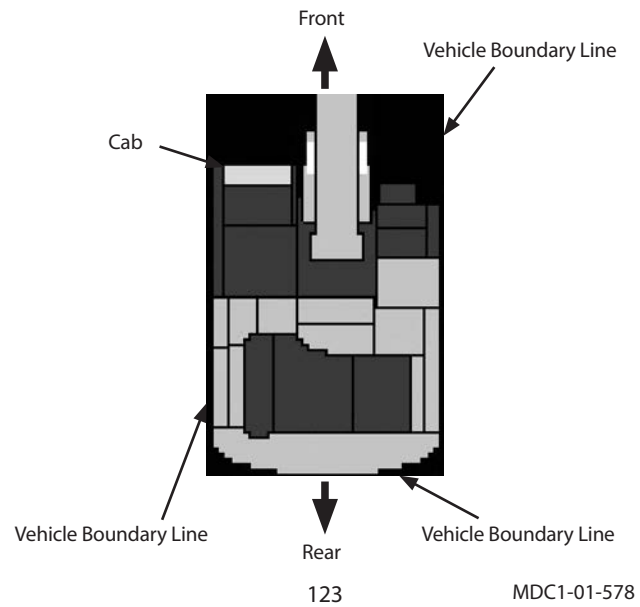

## OPERATOR'S STATION

### Image Behind + Image on Right of Machine

This image is a composite of the images from the rear and right cameras. Camera direction guide icons (1) indicate which camera the displayed image is from.

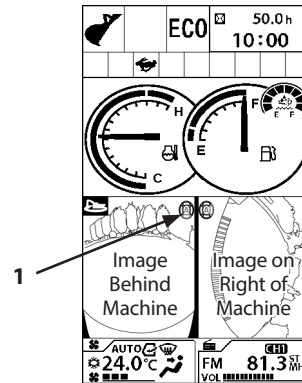

MDC1-01-591

### Image Behind + Image on Right + Image on Left of Machine

This image is a composite of the images from the rear, right and left cameras. Camera direction guide icons (1) indicate which camera the displayed image is from.

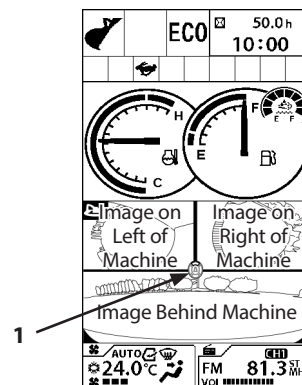

MDC1-01-592

### Camera Direction Guide Icons

Camera direction guide icons indicate which camera the displayed image is from. The arrow in the center of the icon indicates the front of the machine and which image(s) are displayed around the icon indicate which camera the image is from. As illustrated at right, the image from the rear-view camera is displayed on the monitor.

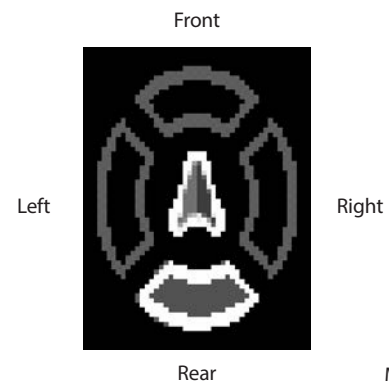

MDC1-01-579



## OPERATOR'S STATION

### Discrepancies between Image and Actual Road Surface

#### 1) Images of Ascending Slopes or Faces

This indicates how the camera looks when shooting uphill. Because point (a) on the upslope is stretched on the monitor screen on an extended line of the plane, the distance from the vehicle icon is depicted as further than it actually is.

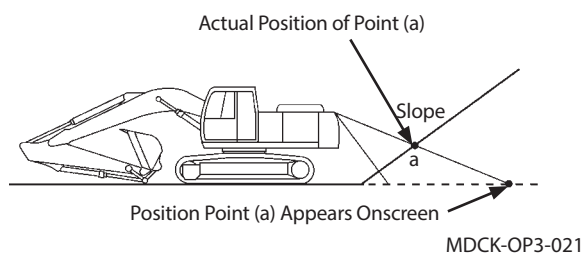

#### 2) Images of Descending Slopes or Cliffs

This indicates how the camera looks when shooting downhill.

Because point (b) on the downslope is shortened on the monitor screen on an extended line of the plane, the distance from the vehicle icon is depicted as closer than it actually is.

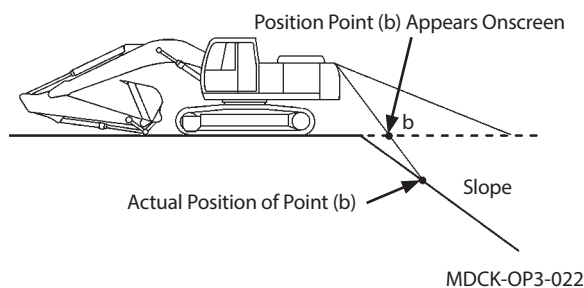

## OPERATOR'S STATION

---

### Cab Door Release Lever

**⚠ CAUTION:**

- **Open the cab door all the way until it securely locks in the latch on the side of the cab.**
- **Do not unlock the cab door when the machine is parked on a slope or while the wind is strong. The cab door may close accidentally, possibly resulting in personal injury.**
- **When opening or closing the cab door, take extra care not to catch fingers between the base machine and the cab door.**

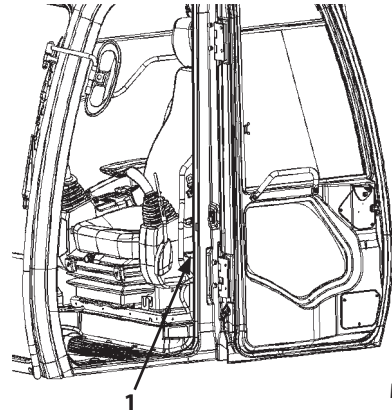

MDCN-01-012

To unlock the door, push down on lever (1).

## OPERATOR'S STATION

---

### Opening/Closing and Removing Cab Inside Window

**⚠ WARNING:**

- **Open, close or remove the upper front cab window, overhead window, cab door window or lower front window only after lowering the front attachment to the ground and pulling up pilot control shut-off lever (1) to the LOCK position. Failure to do so may allow the machine to move unexpectedly if a control lever or pedal is mistakenly touched with a part of the body, possibly resulting in personal injury or death.**
- **Park the machine on a level surface and stop the engine before opening and closing the upper front window.**
- **When opening the upper front window, hold the window by hands, hold it until the upper front window is locked.**
- **When closing the upper front window, it may accidentally fall under its own weight. Hold the upper front window with both hands until it is completely closed. The window stops once before closing completely. Do not operate the machine when the window is in this position. The upper front window is not locked in this position, there is a possibility that the window may drop suddenly.**

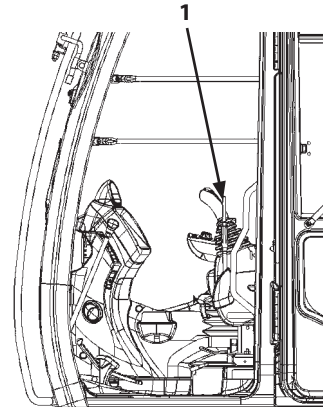

MDCN-01-008

## OPERATOR'S STATION

### Opening Upper Front Window

#### Opening Upper Front Window

1. Press lock release lever (1) at the upper center to release the upper front window lock.
2. Holding lock release lever (1) at the upper center and lower handle (4) on the upper front window as illustrated, pull the upper front window up and back until auto locks (3) at both sides of the upper front window securely catches into the strikers on the ceiling.
3. After confirming that the window securely catches into auto locks (3), slide lock pin (2) into the left bracket boss hole to lock the window in position.

 **NOTE:** When the upper front window is opened, the wiper and washer are inoperable.

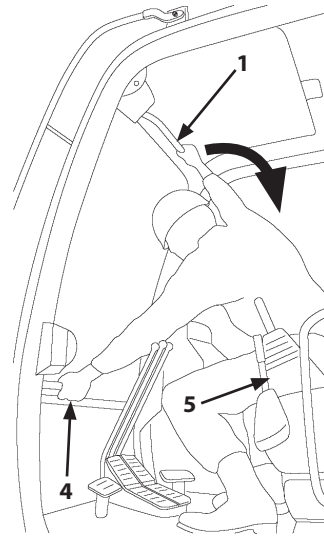

MDAA-01-358

#### CAUTION:

- Slowly close the upper front window that you do not catch your fingers.
- Always secure lock pin (2) in the lock position after the upper front window is opened.
- Always pull pilot control shut-off lever (5) to the LOCK position before opening or closing the upper front window.

4. To close the upper front window, hold lock release lever (1) at the upper center and lower handle (4) on the upper front window as illustrated, and follow steps 1 to 3 in the reverse order. The window stops before it completely closes, so close the front window by pushing release lever (1) upward.

Push lock release lever (1) downward to release auto lock (3).

 **NOTE:** Unless the upper front window is securely closed, the wiper and washer will not operate.

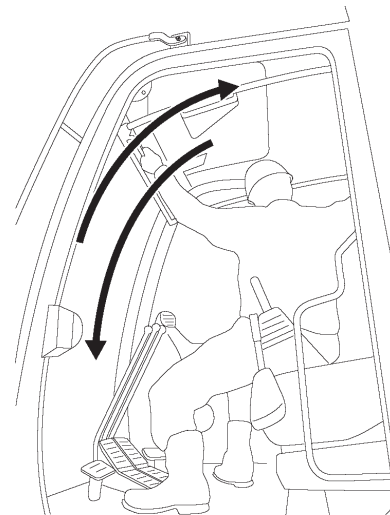

MDAA-01-359

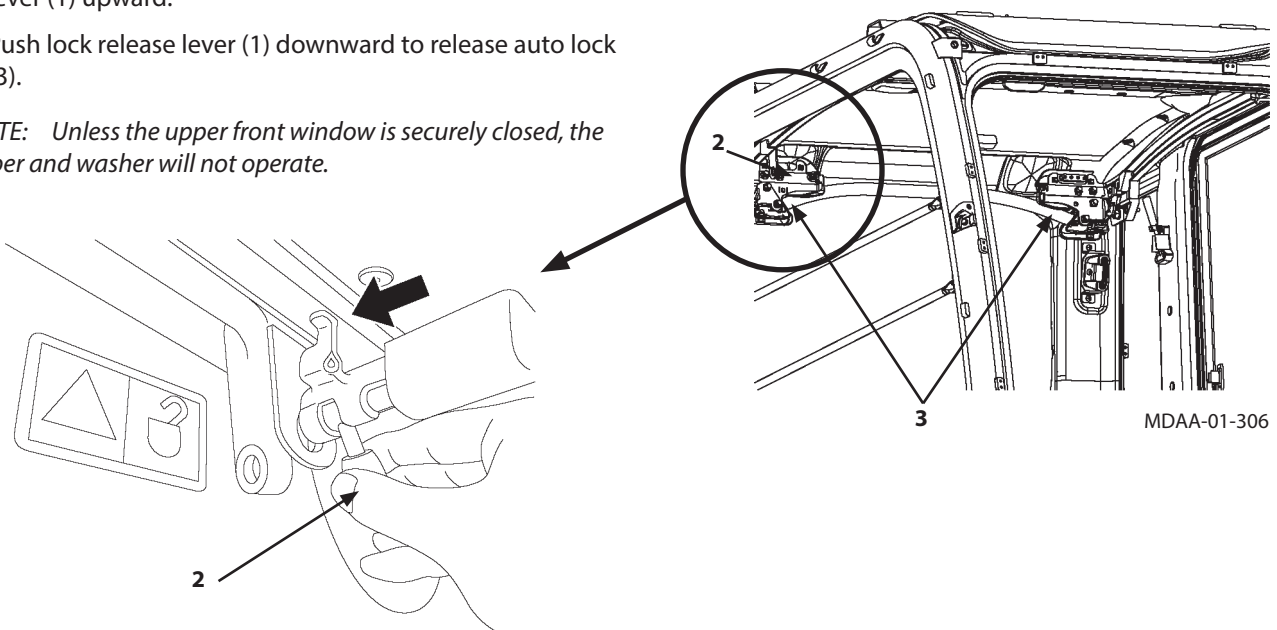

MDAA-01-306

MDAA-01-360

## OPERATOR'S STATION

### Removing and Storing Lower Front Window

**CAUTION:** Take care not to get your fingers caught when handling the lower front window.

#### Removing and Storing Lower Front Window

1. Open the upper front window beforehand when removing the lower front window.
2. While pulling the lower front window inward, raise it to remove.
3. Store the removed windowpane in the storing position. After inserting the windowpane into rubber clips (2 and 3), slide it sideways securely into rubber clip (4). Push fastener (1) to lock.

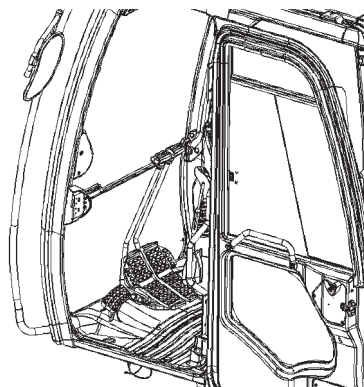

MDCN-01-015

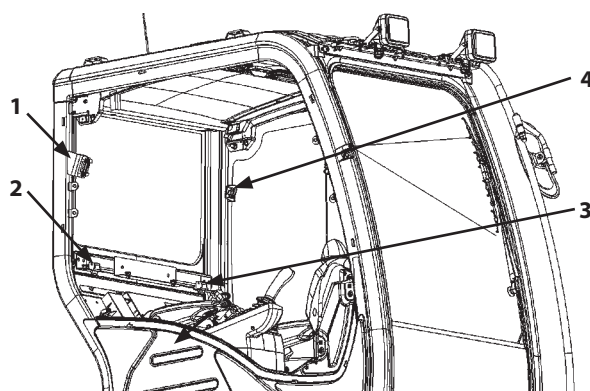

MDCN-01-016

# OPERATOR'S STATION

## Opening Side Window

Hold handle (1) and slide windowpane to open the side window.

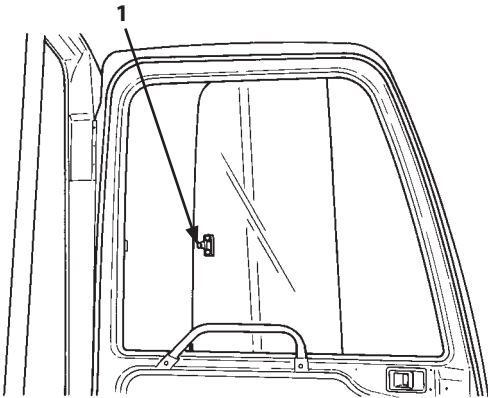

Side Window

M178-01-061

## OPERATOR'S STATION

### Opening and Closing the Roll Screen (for Front and Right Windows) (Optional)

To provide shade and ensure good visibility for the operator, roll screens are fitted.

Roll screens are fitted to the front window and window on the right side to provide shade.

#### **WARNING:**

- **Ensure the pilot control shut-off lever is in the LOCK position when operating the roll screen. The machine may unexpectedly move if the work lever or pedal are mistakenly touched.**
- **Set the bottom of the roll screen (bar(1)) to an appropriate position that does not impede vision.**

#### **IMPORTANT:**

- **Hold the center of the bar (1) when using the screen. If the center is not held, the screen may snag on surrounding parts or belongings and cause injury.**
- **Do not pull strongly on the screen as this may damage or break it.**
- **When opening or closing the front window, store the roll screen on the right window side.**

#### **How to Use on the Front Window**

1. When the roll screen is secure on the right window side, use the procedure below to move it over the front window.  
Secure by sliding lock pin (2) to the left to remove it from receiving part (3), rotating it to the front window side and inserting lock pin (2) into receiving part (4).  
Ensure lock pin (2) is securely inserted into receiving part (4).

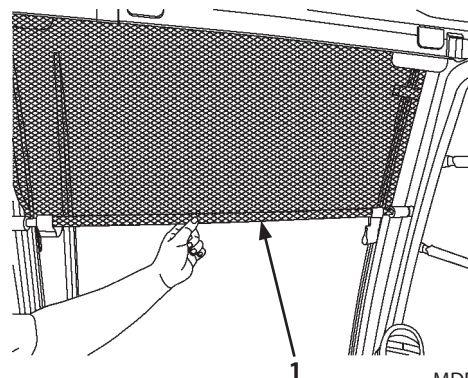

MDFY-01-074

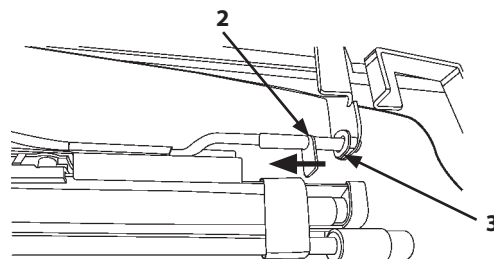

MDFY-01-072

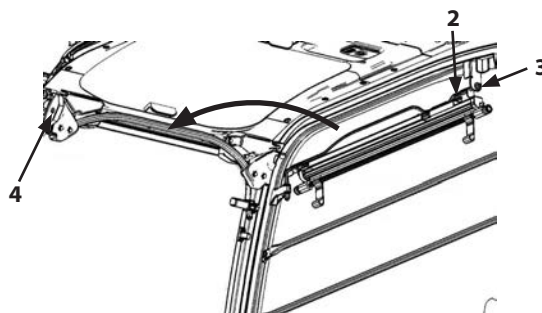

MDFY-01-066

2. Pull the screen down, tilt bar (1) and fit the end into rail (5).

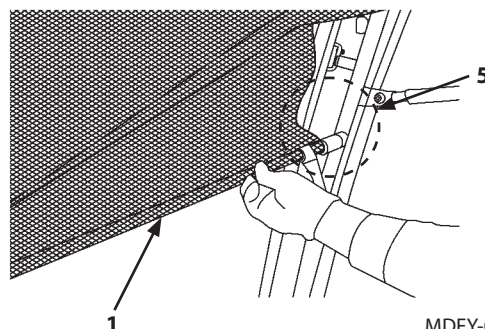

MDFY-01-067

## OPERATOR'S STATION

3. While holding the center of bar (1), press switch (6) and wind up the screen to adjust screen pull-out. The left-right position of the screen can be adjusted by sliding case (7) until it hits stopper (8).

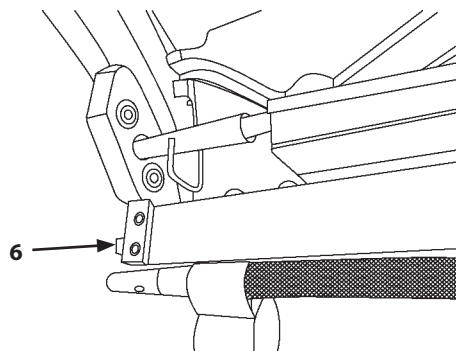

MDFY-01-068

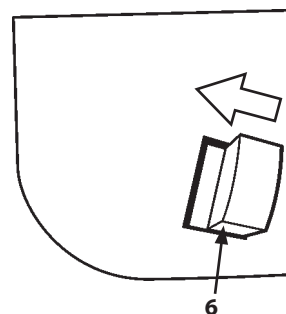

MDC1-01-595

Direction of operation for switch (6)

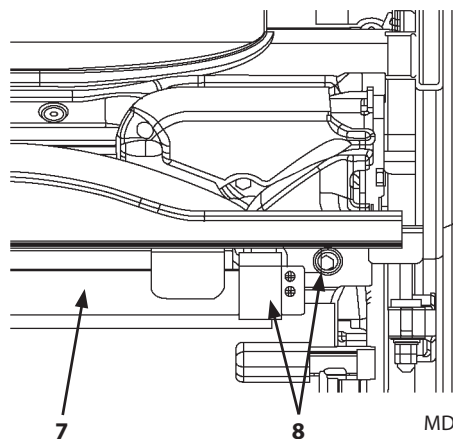

MDFY-01-069



## OPERATOR'S STATION

### How to Store on Right Window Side

When opening or closing the front window, store on the right window side.

1. Perform the reverse of the procedure described in How to Use on the Front Window and move to the right side.
2. While holding the center of bar (1), press switch (6) and fully wind up the screen.

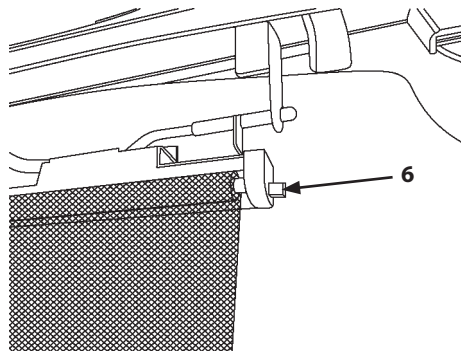

MDFY-01-070

### How to Use on Right Window Side

The screen can be installed on the right window side as protection from the sun.

However, if other items are fitted to pipe (10), use on the right side may not be possible.

1. Secure bar (1) by pulling the screen down and attaching screen fastener (9) to pipe (10).  
If fastener (9) is worn, it may not be able to secure the screen. Fastener (9) can be easily replaced, and should be replaced if it wears out.

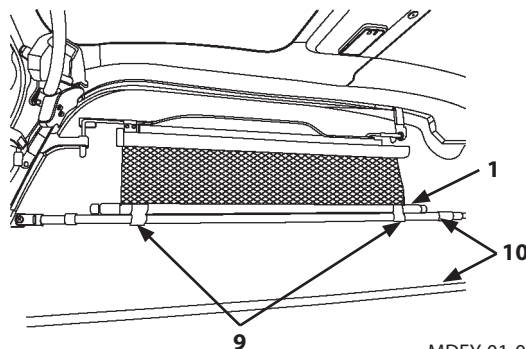

MDFY-01-073

### How to clean the screen

When cleaning the screen, do not use detergents or other cleaning fluids. Use a towel that has been moistened with water and gently wrung and wipe the dirt off gently while supporting the screen with a hand.

If detergent is used or water is applied directly, it may cause the screen condition to deteriorate or wrinkle.

## OPERATOR'S STATION

### Opening/Closing Overhead Window (Clear Hatch)

Move locks (1) toward center of window. Hold handle (2) and lift window until it rises upright. With the window positioned upright, it will be secured in position by dampers (3).

Hold handle (2) and pull window down until "click" sound is heard from left and right locks (1).

Note that the overhead window can be used as an emergency exit.

#### IMPORTANT:

- **Replace the clear hatch with a new one every 5 years even if undamaged. Replace the roof within 5 years if there is any visible damage or it receives a major impact.**
- **When cleaning the clear hatch, use a neutral detergent.**  
**If acidic or alkaline detergent is used, the clear hatch may become discolored or crack.**
- **Keep organic solvent away from the clear hatch.**  
**Failure to do so may cause the clear hatch to become discolored or crack.**

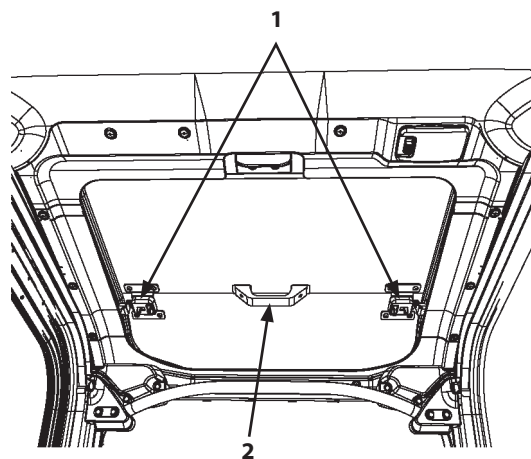

MDAA-01-302

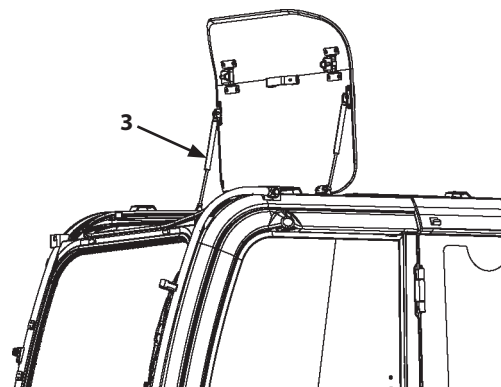

MDAA-01-303

## OPERATOR'S STATION

### Emergency Exit

Escape from the cab in emergency in the following methods:

**CAUTION:** The danger of falling is always present when escaping from the cab in emergency, possibly resulting in serious personal injury. Escape from the cab as safely as possible, depending on the position of the machine and the situation outside.

1. Open the cab door. Escape through the door.
2. If the cab door is difficult to open or use, open the upper front window. Escape through the window.

**NOTE:** Emergency exit decals (2) are affixed to the front and rear windows. See page "OPENING UPPER FRONT WINDOW" for the opening method of the upper front window.

**CAUTION:** If decal (3) is affixed to the front windowpane, the windowpane can be broken. However if decal (3) is not affixed to the front windowpane, the glass cannot be broken with emergency evacuation hammer (1). Take care not to be injured by pieces of broken glass.

3. If the upper front window is difficult to open, check the decal (3) affixed to the windowpane.

If decal (3) is affixed to the front windowpane, break the front windowpane using the emergency evacuation tool (1) installed on the left side of the cab. Escape through the broken windowpane.

4. If decal (3) is not affixed to the front windowpane, or if it is not possible to escape through the front window, break the rear windowpane using emergency evacuation hammer (1). Escape through the broken windowpane.
5. If neither of front and rear windows are available for emergency exit, open the overhead window to escape from the cab.

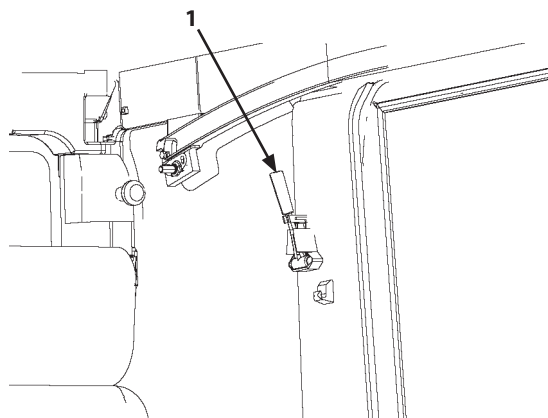

MDAA-01-321

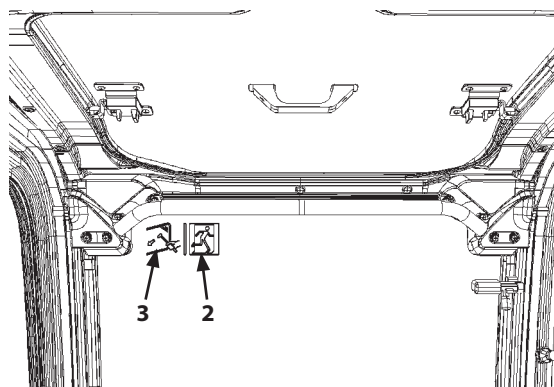

M1U4-01-012

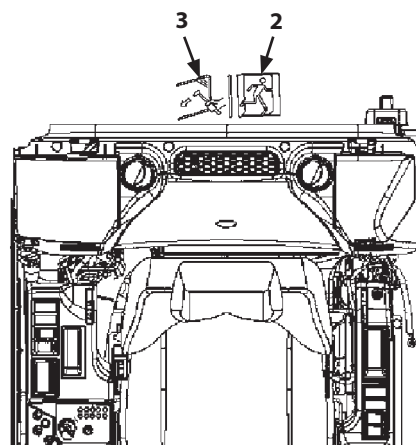

MDCN-01-017

## OPERATOR'S STATION

### Opening and Closing the OPG Front Guard (Optional)

#### **WARNING:**

- Do not release lever (1) when the machine is on a slope.  
The guard may suddenly open.
- To open and close the OPG front guard, hold (A).  
If holding other parts, there is a risk of your hand becoming caught.

**IMPORTANT:** Do not operate the front attachment while the OPG front guard is open.

The front attachment may interfere with the OPG front guard, possibly resulting in damage.

When releasing the lock, pull lever (1) down.

When the OPG front guard is slightly open, lock lever (3) securely on the cab side.

When the OPG is fully open, lock lever (4) securely on the guard side.

When closing the OPG front guard, hold (A) and close the front guard until the locking mechanism is properly engaged with the catch (2).

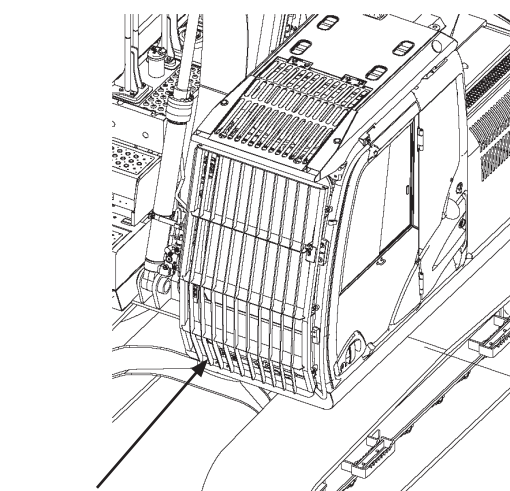

OPG Front Guard

MDC1-07-088

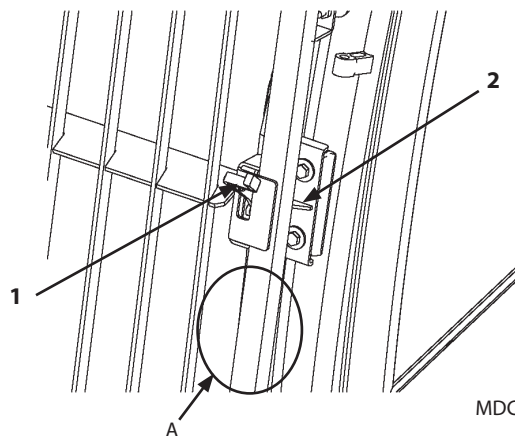

MDC1-07-089

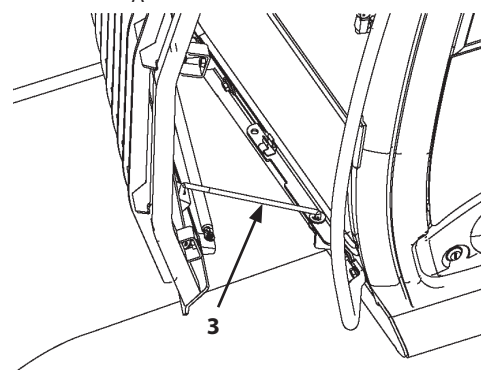

MDC1-07-090

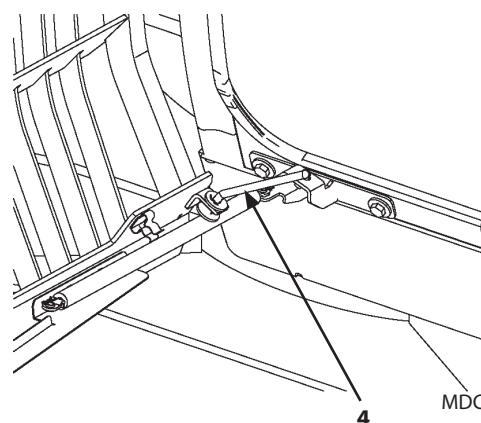

MDC1-07-091

## OPERATOR'S STATION

### Adjusting Operator's Seat

**⚠ WARNING:** Adjust the seat only after lowering the front attachment on the ground and pulling up the pilot control shutoff lever to the LOCK position. Failure to do so has the risk of operator's part of body touch the control lever or pedal by mistake, allowing the machine to move unexpectedly, which may result in personal injury or death.

**⚠ CAUTION:** Avoid possible injury while operating height/tilt lever (1). When pushing down lever (1), do not grab it. Fingers may be pinched between lever (1) and the seat stand. Be sure to push on the upper face of lever (1) by your palm.

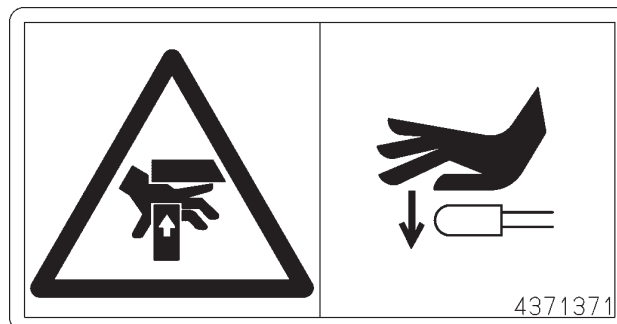

SS4371371-3

#### Seat Height and Angle Adjustment

Seat height adjustment range is 60 mm with steps every 15 mm (5 positions in total).

Push down lever (1): to adjust front part of the seat.

Pull up lever (1): to adjust rear part of the seat.

#### Console and Seat Fore-aft Adjustment

Operate console and seat slide lever (2) to adjust the seat and both right and left consoles to desired distance from the travel pedals and levers. Seat and console fore-aft adjustment range is 160 mm with steps every 20 mm.

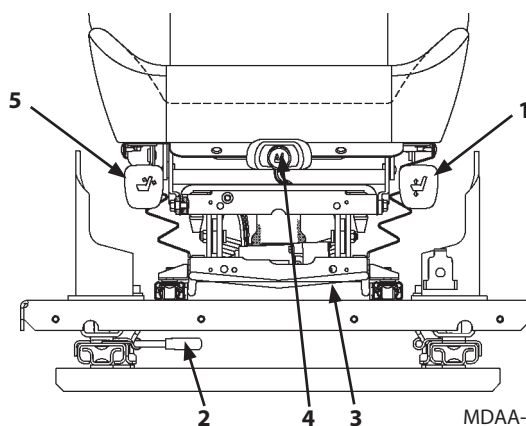

MDAA-01-332

#### Seat Fore-Aft Adjustment

Operate seat slide lever (3) to adjust the seat to desired distance from the travel pedals and levers. Seat and console fore-aft adjustment range is 200 mm with steps every 10 mm.

#### Suspension Adjustment

**IMPORTANT:** The seat is supported by the air suspension system. Turn the key switch ON to supply air from the compressor.

Push and pull knob (4) to adjust the suspension. Pull the knob forward to release air, which makes it soft. Push the knob backward to fill air, which makes it hard.

## OPERATOR'S STATION

---

### Backrest Adjustment

Pull up lever (5) to release backrest lock. Move backrest to the desired position and release lever (5).

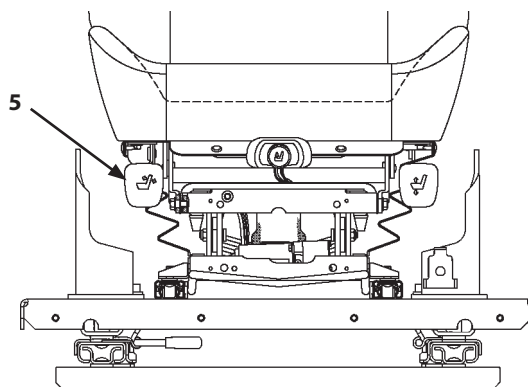

MDAA-01-332

### Armrest Adjustment

Armrest (6) can be pulled upright by hand 90°. Pull the armrest upright by hand to get on and off the machine easily. The angle of armrest (6) can be adjusted to the desired position by turning adjusting dial (7) located on the bottom of armrest (6).

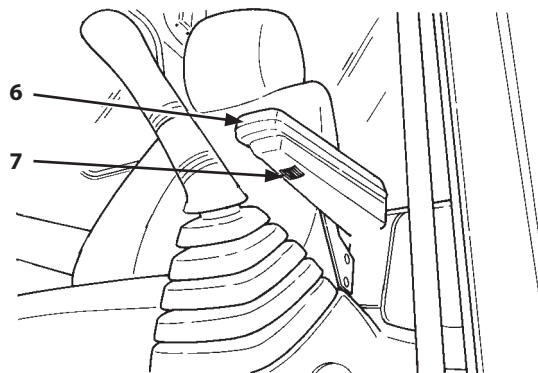

M1G6-01-017

## OPERATOR'S STATION

### Adjusting Operator's Seat (Optional)

**WARNING:** Adjust the seat only after lowering the front attachment to the ground and pulling up the pilot control shut-off lever to the LOCK position. Failure to do so may allow the machine to move unexpectedly if a control lever or pedal is mistakenly touched with a part of the body, possibly resulting in personal injury or death.

#### Adjusting Seat Height

**IMPORTANT:** The seat is an air suspension type.

Pull lever (1) upward to fill air and raise the seat. Push lever (1) downward to release air and lower the seat. When the seat is properly adjusted for your weight, indicator (2) is in the green zone.

#### Console and Seat Fore-aft Adjustment

Operate console and seat slide lever (3) to adjust the seat and both right and left consoles to desired distance from the travel pedals and levers. Seat and console fore-aft adjustment range is 80 mm with steps every 20 mm.

#### Seat Fore-Aft Adjustment

Operate seat slide lever (4) to adjust the seat to desired distance from the travel pedals and levers. Seat fore-aft adjustment range is 140 mm with steps every 10 mm.

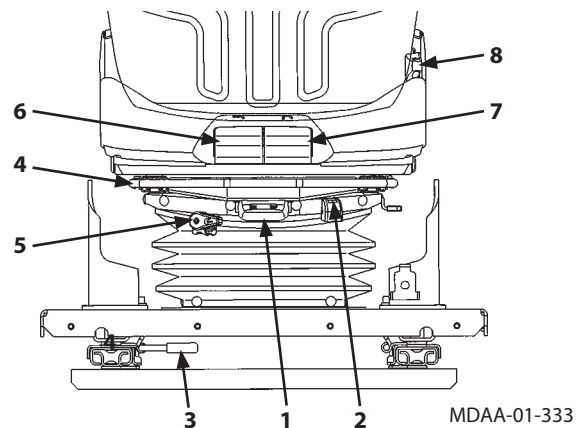

## OPERATOR'S STATION

### Suspension Adjustment

Rotate knob (5) to adjust the suspension.

Rotate knob (5) clockwise to decrease suspension stiffness.

Rotate knob (5) counterclockwise to increase suspension stiffness.

### Fore-Aft Position Adjustment of Seat Surface

Pull lever (6) upward to adjust the seat angle. Seat and console fore-aft adjustment range is 60 mm with steps every 15 mm.

### Angle Adjustment of Seat Surface

Pull lever (7) upward to adjust the seat angle. Height of the seat end is adjustable in 4 steps.

### Backrest Adjustment

Pull up lever (8) to release backrest lock. Move backrest to the desired position. Move backrest to the desired position and release lever (8).

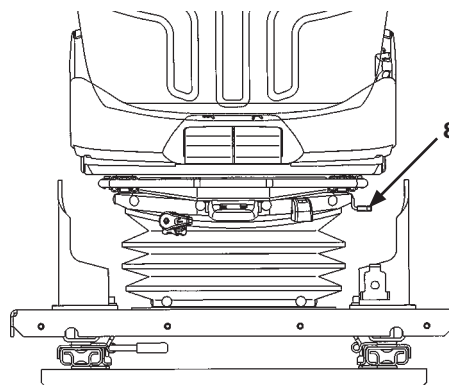

MDAA-01-333

### Armrest Adjustment

Armrest (9) can be pulled upright by hand 90°. Pull the armrest upright by hand to get on and off the machine easily. The angle of armrest (9) can be adjusted to the desired position by turning adjusting dial (10) located on the bottom of armrest (9).

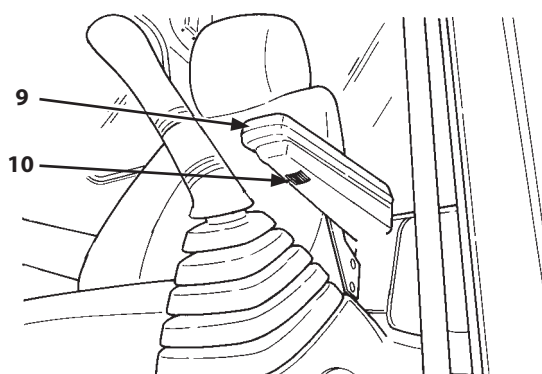

M1G6-01-017



## OPERATOR'S STATION

---

### Console Height Adjustment

Adjust the console height to the operator's comfort and/or work conditions.

Console height can be vertically adjusted to 3 positions at 20 mm intervals.

**⚠ CAUTION:** Before adjusting the console, support the console. Failure to do so may result in the console dropping suddenly, possibly causing personal injury.

#### Adjusting Procedures

1. Lower the bucket to the ground. Stop the engine.
2. Move the pilot control shut-off lever to the LOCK position.
3. Remove left and right console holding bolts (1). Loosen bolts (2) to adjust the console height.
4. After adjusting, tighten bolts (1) and (2).

Tightening Torque: 50 N·m (5.0 kgf·m)

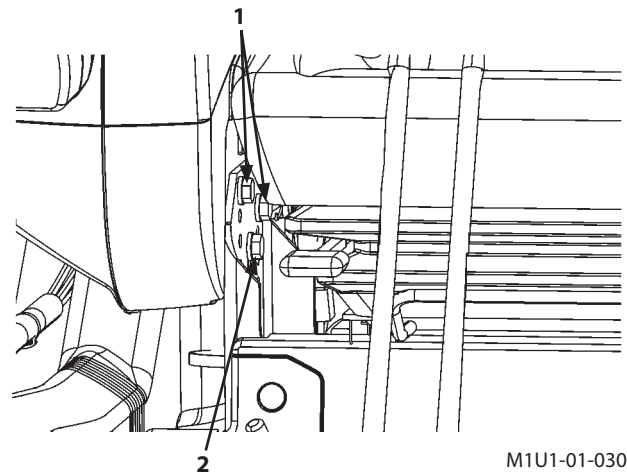

M1U1-01-030

## OPERATOR'S STATION

---

### Installation and Adjustment of Mirrors

**⚠ WARNING:**

- Adjust the mirrors, referring to the field of vision in the mirrors in the "VISIBILITY MAP" chapter. Perform adjustment with the machine position as shown.
- If the mirrors are adjusted improperly, the field of vision cannot be ensured and/or will be obstructed, which may result in serious personal injury.
- Check the field of vision in the mirrors every day before starting work.
- If any of the mirrors are dirty, clean them.
- Ensure appropriate footing when adjusting or cleaning mirrors.

**IMPORTANT:** Mirrors and cameras only act as aids. Before operating the machine, always check the area around the machine thoroughly.

**IMPORTANT:** If a modification is made that could restrict the field of vision, it may result in an obstruction to the field of vision, so check the field of vision again.

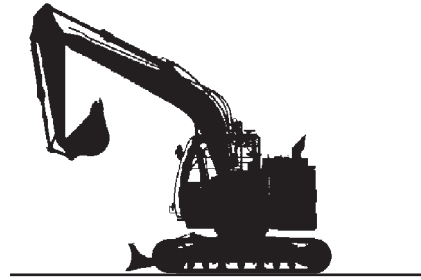

Machine Position Image  
(Monoblock Boom)

MDAT-VM-001

## OPERATOR'S STATION

### Mirror Installation Diagram

The mirror installation locations (1, 2, 3, 4, 5, 6) on this machine are shown in the right.

Adjust the installation locations of each mirror by following the instructions below to ensure safety.

Installation angle and dimension varies depending on the model.

- 1- Operator's Seat Mirror
- 2- Handrail Mirror for Getting ON/OFF the Machine
- 3- Handrail Mirror for Getting ON/OFF the Machine
- 4- Oil Tank Handrail Mirror
- 5- Oil Tank Handrail Mirror (ZX135US-6 only)
- 6- Counterweight Mirror (ZX225USLC-6 only)
- 7- Fuel Tank Handrail Mirror (ZX345USLC-6 only)
- 8- Aftertreatment Device Cover Mirror (ZX345USLC-6 only)

The following models are not equipped with oil tank handrail mirrors (4) (5) or counterweight mirror (6).

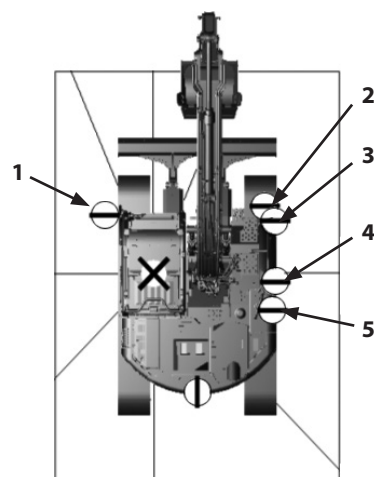

ZX135US-6

MDAT-01-225

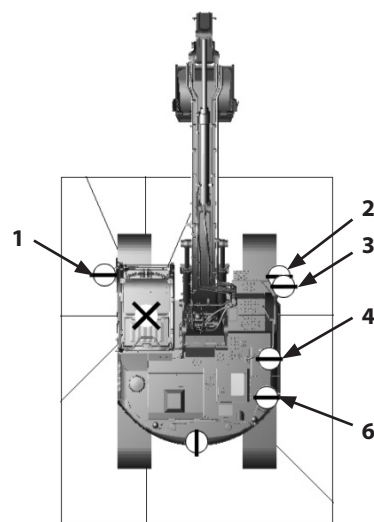

ZX225USLC-6

MDAT-01-226

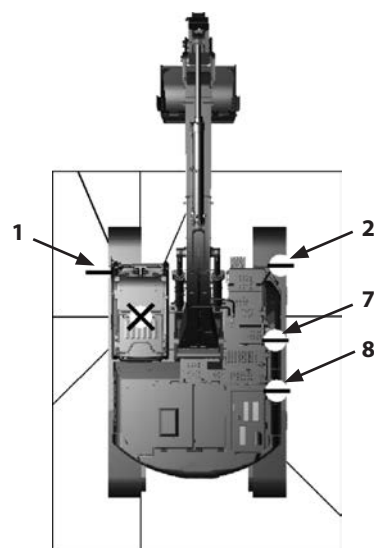

ZX345USLC-6

MDD5-01-012

# OPERATOR'S STATION

- Operator's Seat Mirror (1)  
Adjust the mirror to the specified position.

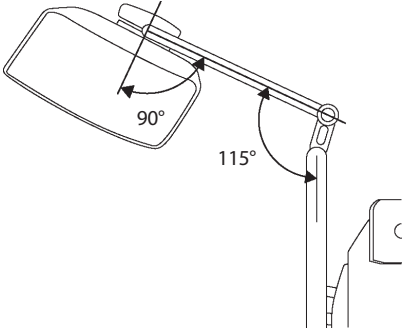

ZX135US-6, 225USLC-6      MDAT-01-271

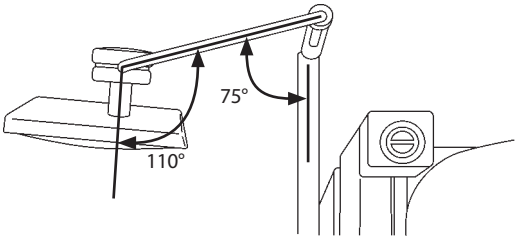

ZX345USLC-6      MDC1-01-549

## OPERATOR'S STATION

- Handrail Mirror for Getting ON/OFF the Machine (2)

Adjust the mirror to the specified position.

Adjust the mirror so that a range of at least 1 m from the right side of the machine can be seen from the operator's seat.

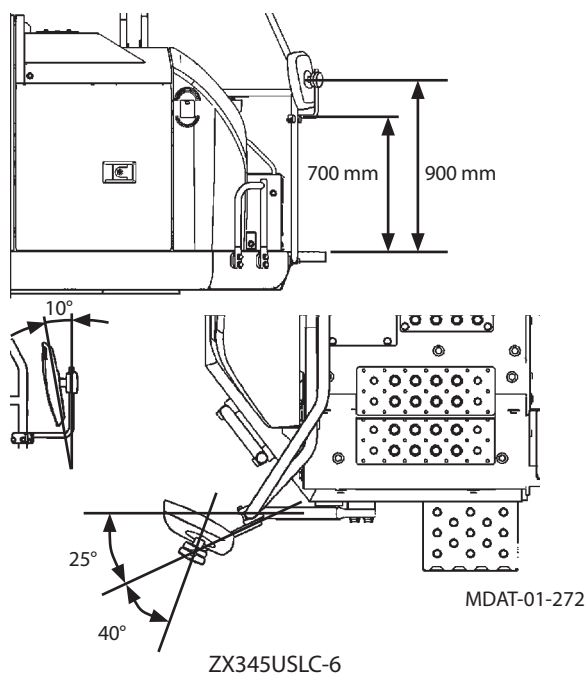
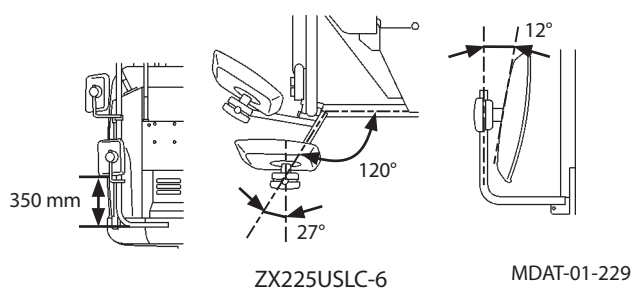
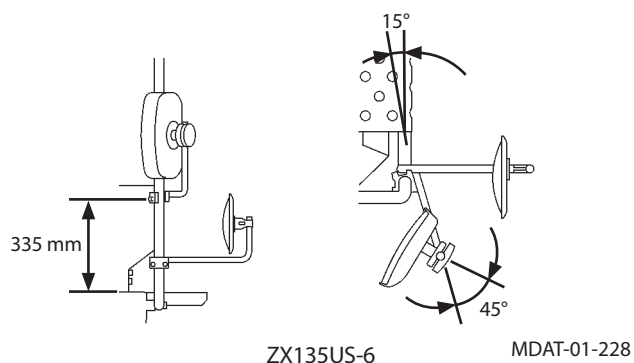

## OPERATOR'S STATION

- Handrail Mirror for Getting ON/OFF the Machine (3)  
Adjust the mirror to the specified position.  
Adjust the mirror so that a range of at least 1 m from the right side of the machine can be seen from the operator's seat.

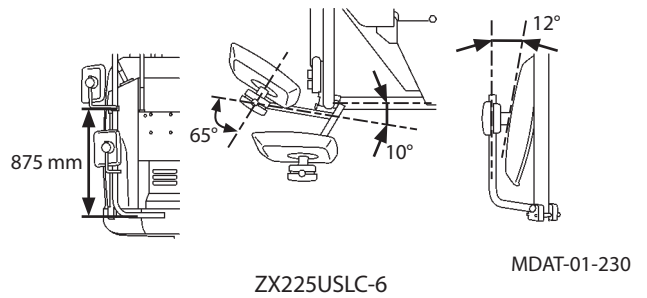
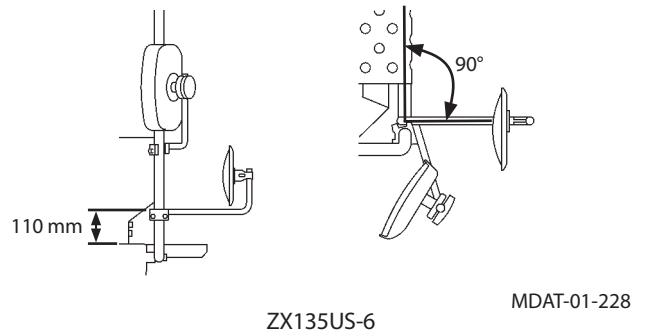

- Oil Tank Handrail Mirror (4)  
Adjust the mirror to the specified position.  
Adjust the mirror so that a range of at least 1 m from the right side of the machine can be seen from the operator's seat.

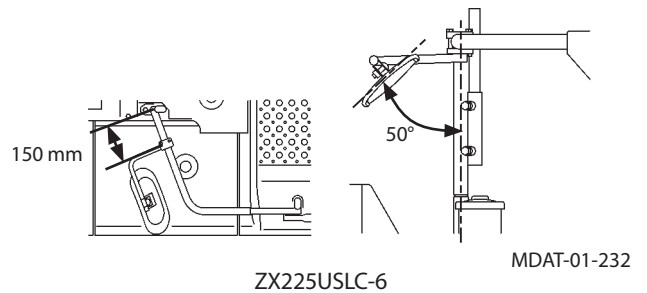
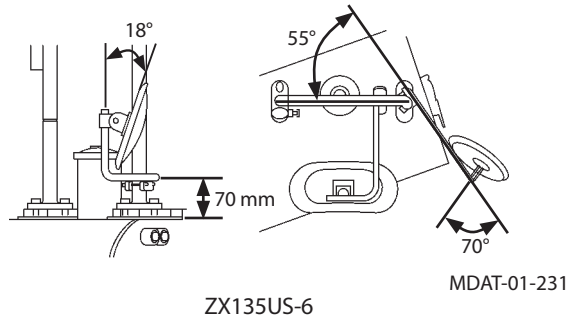

## OPERATOR'S STATION

- Oil Tank Handrail Mirror (5) (ZX135US-6 only)  
Adjust the mirror to the specified position.  
Adjust the mirror so that a range of at least 1 m from the right side of the machine can be seen from the operator's seat.

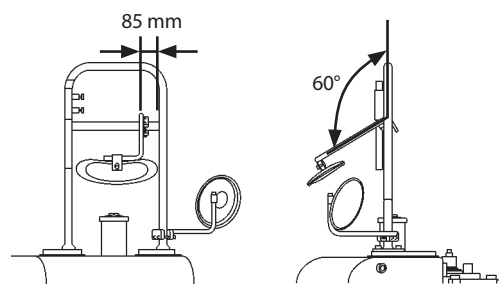

ZX135US-6

MDAT-01-233

- Counterweight Mirror (6) (ZX225USLC-6 only)  
Adjust the mirror to the specified position.  
Adjust the mirror so that a range of at least 1 m from the right side of the machine can be seen from the operator's seat.

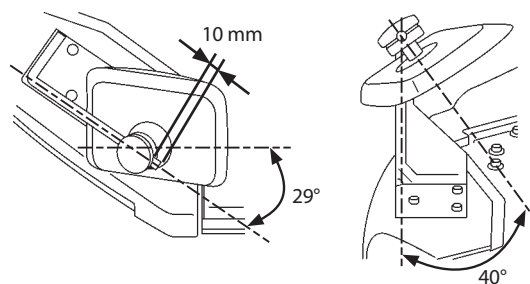

ZX225USLC-6

MDAT-01-234

## OPERATOR'S STATION

- Fuel Tank Handrail Mirror (7) (ZX345USLC-6 only)  
Adjust the mirror to the specified position.  
Adjust the mirror so that a range of at least 1 m from the right side of the machine can be seen from the operator's seat.

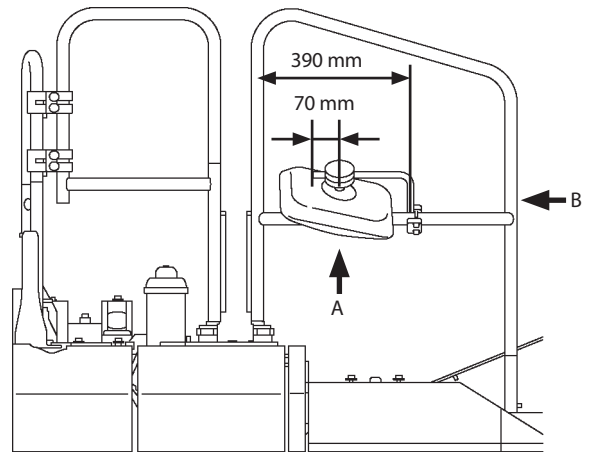

ZX345USLC-6

MDD5-01-005

View A

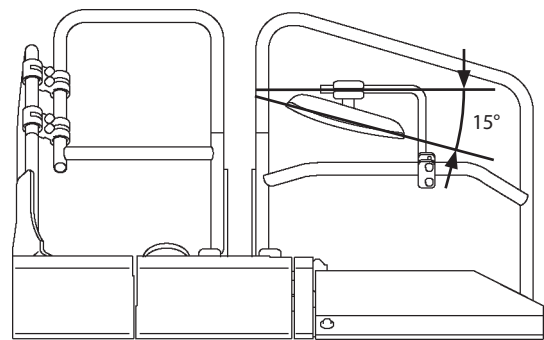

ZX345USLC-6

MDD5-01-006

View B

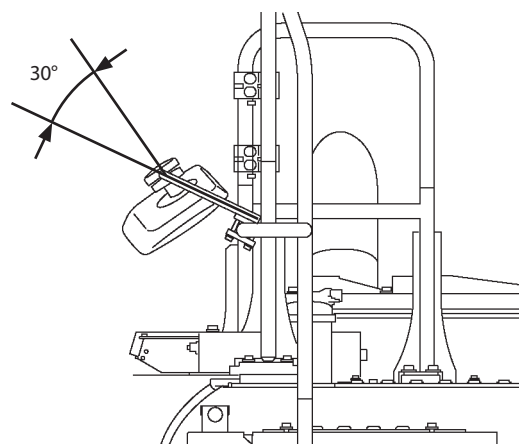

ZX345USLC-6

MDD5-01-007



## OPERATOR'S STATION

- Aftertreatment Device Cover Mirror (8) (ZX345USLC-6 only)  
Adjust the mirror to the specified position.  
Adjust the mirror so that a range of at least 1 m from the right side of the machine can be seen from the operator's seat.

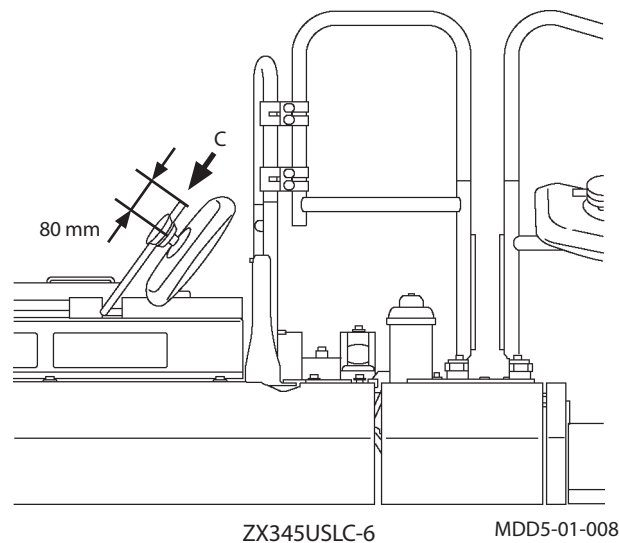

View C

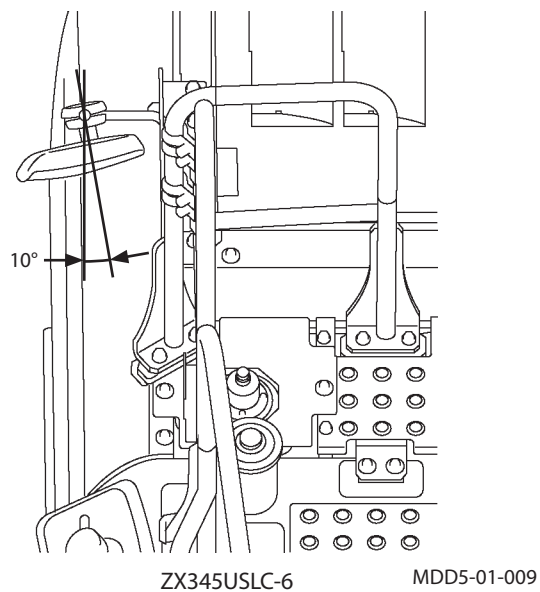

## OPERATOR'S STATION

### Seat Belt

#### WARNING:

- Be sure to use seat belt (1) when operating the machine.
- Before operating the machine, be sure to examine seat belt (1) and attaching hardware for any failure. If any damage and/or wear are found, replace the part concerned.
- Replace seat belt (1) every 3 years regardless of appearance.
- Consult your authorized dealer for replacement.

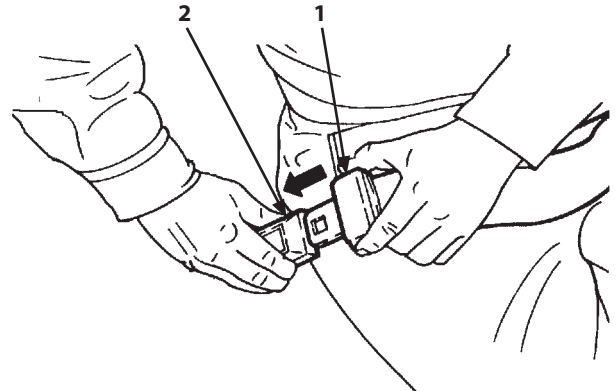

M1U1-01-031

### Seat Belt

1. Confirm that seat belt (1) is not twisted. Securely insert the end of seat belt (1) into buckle (2). Lightly pull on the belt to confirm that the buckle latches securely.
2. Push button (3) on buckle (2) to unfasten seat belt (1).

Replace seat belt (1) if it is damaged or worn, or if the machine is involved in an accident which puts severe stress on the seatbelt.

If the engine is operated without fastening seat belt (1) and the pilot control shut-off lever is lowered, the buzzer sounds after 5 seconds.

After 30 seconds the buzzer changes from a long to a short intermittent buzzing.

Fastening the seat belt makes the buzzer stop.

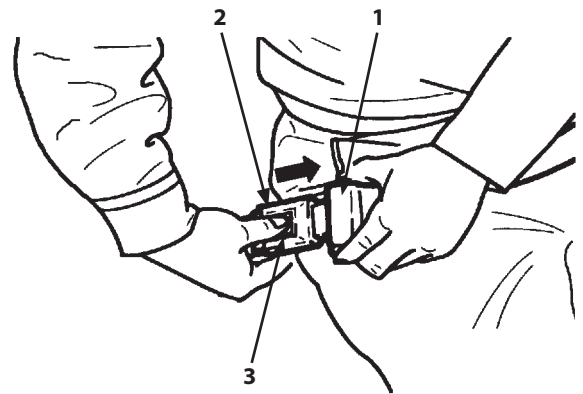

M1U1-01-032

## OPERATOR'S STATION

### Battery Disconnect Switch

#### IMPORTANT:

- Do not turn the battery disconnect switch OFF while engine is running or the key switch is in another position than the OFF position. Failure to do so may damage the electrical system.
- The DEF/AdBlue® Pump runs for a while after the engine stops to return DEF/AdBlue® from piping to the DEF/AdBlue® tank. Do not turn the battery disconnect switch OFF when lamp (2) is lit. Doing so may cause damage to parts related to the Urea SCR system and/or system malfunction.

The battery disconnect switch differs from the engine start key switch. When the battery disconnect switch is turned OFF, the electrical system is cut off, so no electric current flows into the entire circuit.

Before turning the battery disconnect switch OFF, be sure to turn the key switch OFF and wait 5 minutes or more after the engine stops. If the battery disconnect switch is turned OFF within 5 minutes after the engine stops, it may result in malfunction of the electrical system. When the battery disconnect switch is turned from OFF to ON, the preset data of the radio or clock may be initialized. Set the radio and clock again.

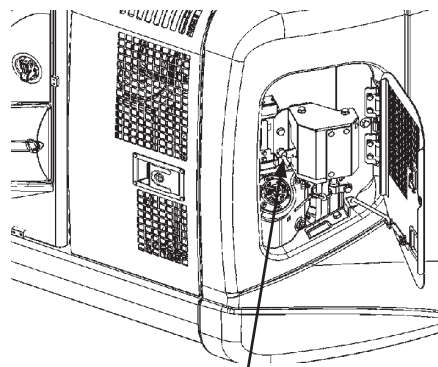

Battery Disconnect Switch  
ZX135US-6 M DAT-01-236

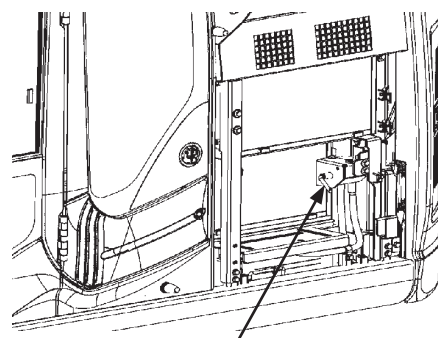

Battery Disconnect Switch  
ZX225USLC-6 M DAT-01-237

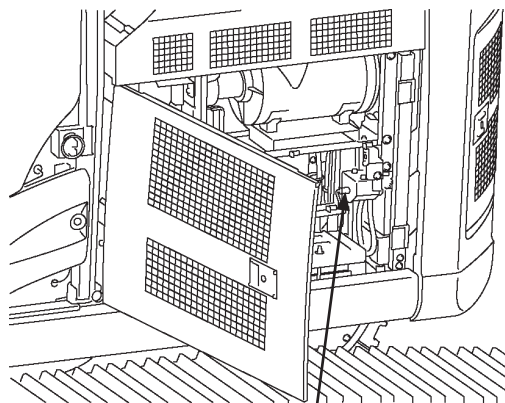

Battery Disconnect Switch  
ZX345USLC-6 M D D5-01-010

## OPERATOR'S STATION

- Refer to the page 1-121 "AM/FM Radio Operation" for the turning of radio.
- Refer to the page 1-39 "Setting Menu" and 1-40 "Data and Time" for the setting of clock.
- Refer to the page 1-113 "Auto Air Conditioner" for the setting of air conditioner.

Use the battery disconnect switch for the following purposes only.

- Before maintaining or servicing the electrical system
- Before storing the machine for long period of time, preventing the battery discharge
- Before welding operation on the machine body
- Before replacement of the battery

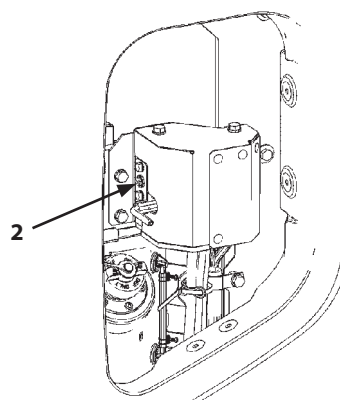

ZX135US-6

MDAT-01-240

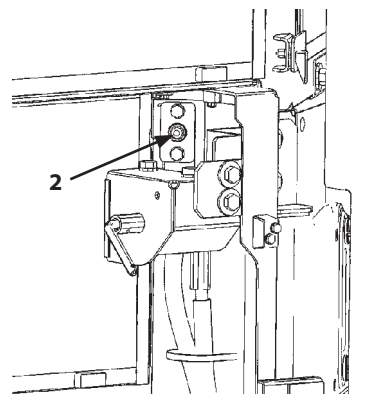

ZX225USLC-6

MDAT-01-239

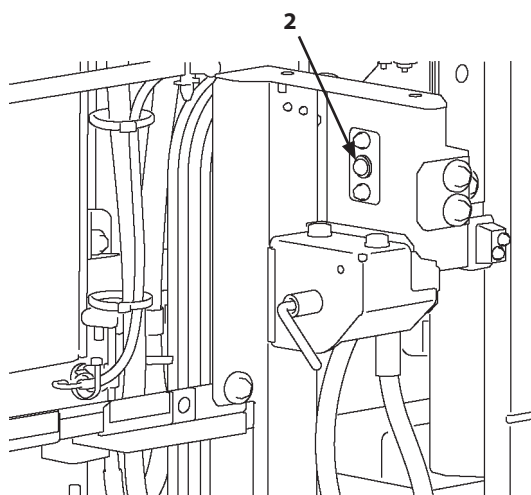

ZX345USLC-6

MDD5-01-011

# OPERATOR'S STATION

## Switch Operation

1. Open cover (1).

When lever (3) is in the horizontal position, the battery disconnect switch is ON. When lever (3) is in the vertical position, the battery disconnect switch is OFF. When lever (3) is in the horizontal position, lever (3) can not be removed.

2. Check that lamp (2) is not lit. Lamp (2) goes off 5 minutes after the key switch is turned to OFF.

3. When lever (3) is turned counterclockwise to the vertical position, the battery disconnect switch turns OFF. Lever (3) can be removed from the battery disconnect switch when it is in the OFF position.

 NOTE: Some models are not equipped with lamp (2).

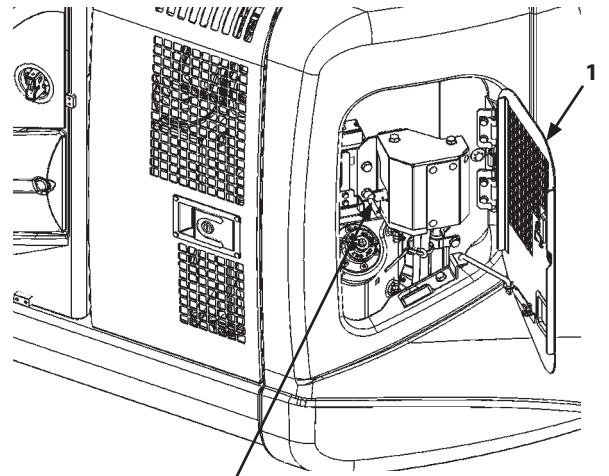

MDAT-01-003

ZX135US-6

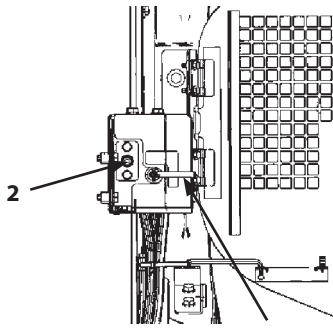

ON  
ZX135US-6

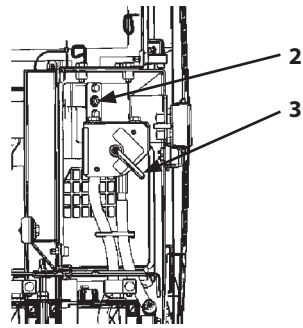

ON  
MDAT-01-264  
ZX225USLC-6

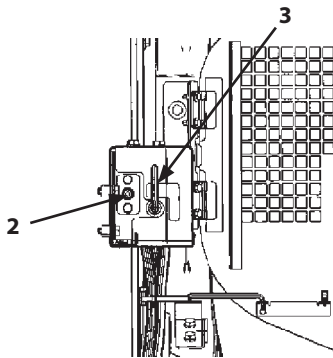

OFF  
ZX135US-6

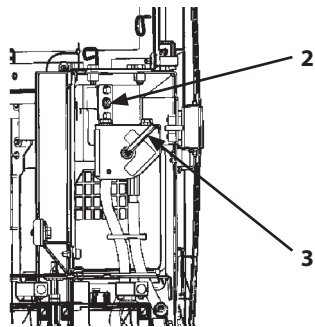

OFF  
MDAT-01-265  
ZX225USLC-6

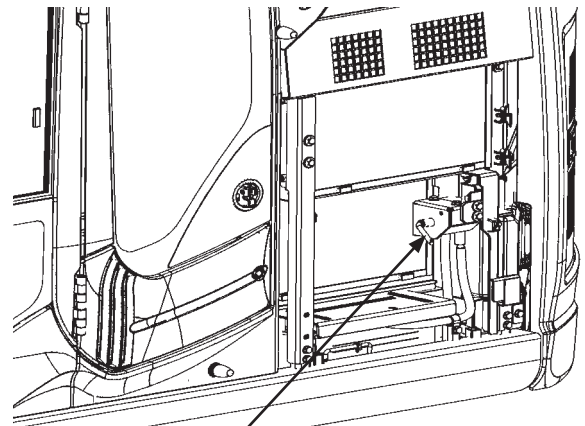

MDAT-01-004

ZX225USLC-6

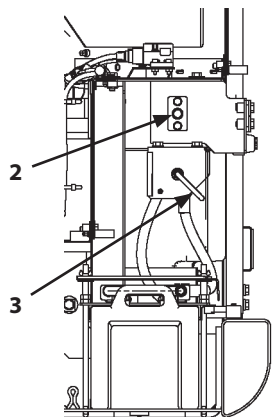

ON

ZX345USLC-6

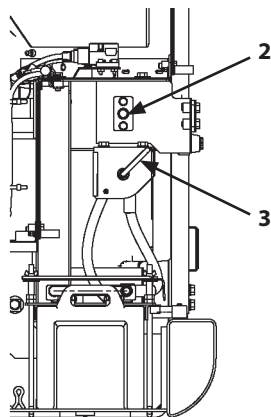

OFF

MDAT-01-273

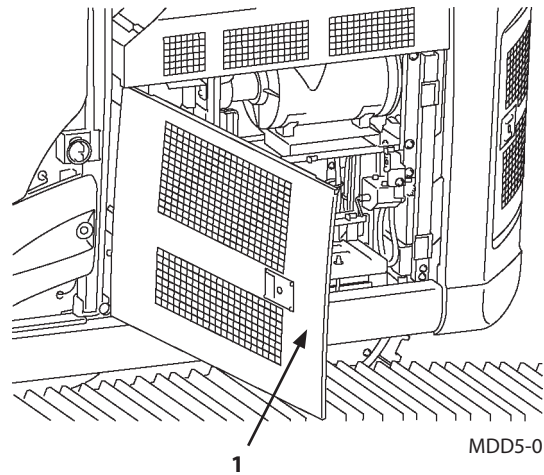

MDD5-01-010

ZX345USLC-6

## BREAK-IN

---

### Observe Engine Operation Closely

**IMPORTANT:** Use extra caution during the first 50 hours of operation, until you become thoroughly familiar with the sound and feel of your new machine.

1. Only operate the machine in economy (ECO) mode and limit engine horsepower to around 80 % of its full load.
2. Avoid excess engine idling.
3. Check indicator lights and gauges frequently during operation.

### Every 8 Hours or Daily

1. Perform 8-hour or daily service.
2. Watch for fluid leaks.
3. Lubricate working tool pivots every 8 hours for the first 50 hours, and every 8 hours when working in mud and water.

### After the First 50 Hours

1. Perform 50-hour service.
2. Check accessible hardware torque. (See Hardware Torque Specifications in Maintenance chapter.)

### After the First 100 Hours

Perform 50-hour and 100-hour service.



## OPERATING THE ENGINE

---

### Inspect Machine Daily Before Starting

Perform the required daily check before starting the engine.

#### Engine

- Level of engine oil and coolant\*
- Ease of starting, exhaust gas color, and noise
- Oil and water leaks, damage to hoses and pipe lines\*
- Clogging and damage to radiator, oil cooler and intercooler\*
- Loose and/or missing mounting bolts and nuts\*

#### Upperstructure

- Fuel level, leaks and contamination of fuel in tank\*
- Level, leaks and contamination in DEF/AdBlue® tank
- Hydraulic oil level, contamination of hydraulic oil, leaks from hydraulic oil tank\*
- Movement, play and operating force of all control levers
- Operation of all hydraulic components, oil leaks and damage to pipings and hoses\*
- Deformity, breakage, and abnormal noise at each part
- Loose and/or missing mounting bolts and nuts\*
- Washer fluid\*
- Leaks from DEF/AdBlue® hoses
- Dirt around the aftertreatment device

#### Undercarriage

- Sag, wear and damage to crawler\*
- Oil leaks and wear on upper/lower rollers and front idlers
- Oil leaks from travel devices
- Loose and/or missing mounting bolts and nuts\*

#### Working Device

- Check cylinders, pipe lines and hoses for oil leaks and damage\*
- Wear and damage to the bucket
- Check for missing, loose and/or worn bucket teeth\*
- Condition of lubrication of the working device\*
- Check for damage to pin anti-extraction pins, stoppers, rings and bolts
- Loose and/or missing mounting bolts and nuts\*



## OPERATING THE ENGINE

---

### Others

- Operation of instruments, switches, lights and buzzer/horn\*
- Function of parking brake
- Deformity and/or breakage to the head guard
- Abnormal outside appearance of machine
- Wear and damage of the seat belt\*
- Aerial angle camera images\*



*NOTE: Item with \*mark: Refer to "Maintenance" section for detailed information.*

# OPERATING THE ENGINE

## Before Starting Engine

1. Ensure that the battery disconnect switch is in the ON position.
2. Confirm that pilot control shut-off lever (1) is in the LOCK position.
3. Confirm that all control levers are placed in neutral.
4. Insert key (2) to the key switch. Turn it to ON position. Push and hold switch (3) with the engine stopped.

**IMPORTANT:** Always check the machine on a firm, level surface. Never attempt to start the engine while checking the machine.

If engine oil level alarm (4) (green) and coolant level alarm (5) (green) are displayed, the engine status is normal.

5. Adjust the seat to allow full control pedals and levers stroke with operator's back against the backrest. Fasten the seat belt.

 **NOTE:** The monitor surface is a resin product. When the surface becomes dusty, lightly wipe the surface with a wet cloth. Never use an organic solvent.

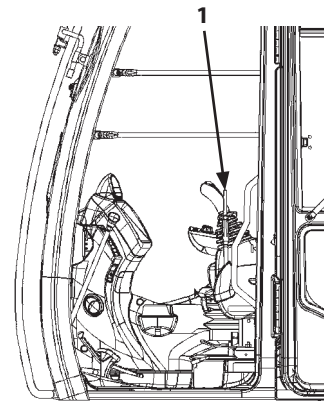

LOCK Position

MDCN-01-008

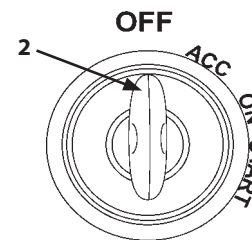

MDC1-01-502

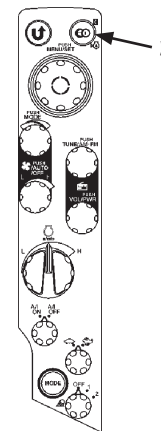

MDCD-01-026

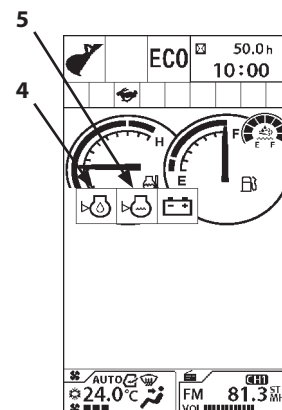

MDC1-01-041

# OPERATING THE ENGINE

## Starting the Engine

### Starting the Engine in Ordinary Temperature

1. Confirm that pilot control shut-off lever (1) is in the LOCK position.
2. Turn engine control dial (3) to the slow idle position.
3. Sound horn to alert bystanders
4. Insert key (2) to the key switch. Turn it to ON position.
5. "Wait-screen (nothing is displayed)" is displayed on the monitor for 2 seconds. Regardless of pilot control shut-off lever (1) position, the engine can not be cranked during this moment.
6. When the Password Input screen is displayed on the monitor, input the password. Unless the numeric keypad function (ignition block system) is activated, this screen is not displayed.

**IMPORTANT:** When required to activate the numeric keypad function (ignition block system), consult your authorized dealer.

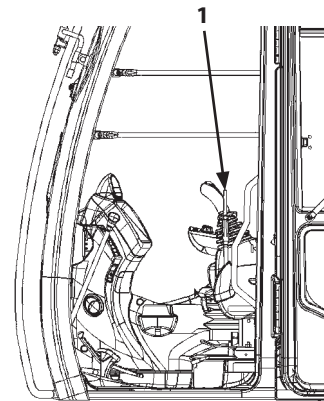

LOCK Position

MDCN-01-008

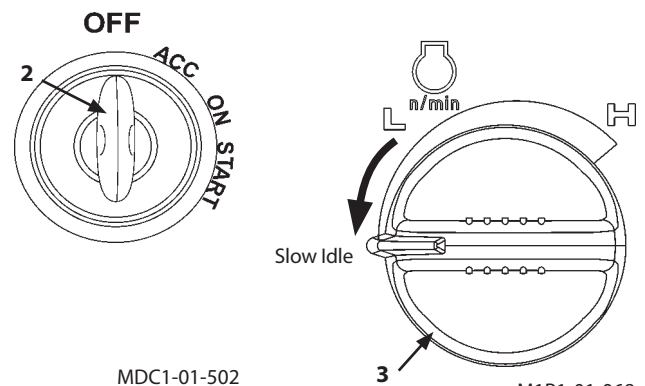

MDC1-01-502

M1P1-01-068

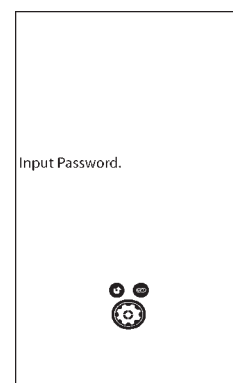

Password Input Screen

MDAA-01-085EN

## OPERATING THE ENGINE

 **NOTE:** When the key switch is turned ON, the maintenance notification (4) for the item whose maintenance interval has expired displays for 10 seconds. Push Return to Previous Screen switch (5) or turn the pilot control shut-off lever to the UNLOCK position while the rear view camera is enabled to delete the notification.

7. The Basic Screen will be displayed on the monitor. Check that the preheat indicator (6) is OFF at this time.
8. Turn key switch to the START position to rotate the starter. The engine will start.

**IMPORTANT:** Never operate the starter for more than 10 seconds at a time. If the engine fails to start, return the key switch to the OFF position. Wait for more than 30 seconds, then try again. Failure to do so may cause damage to the starter and/or discharge the batteries.

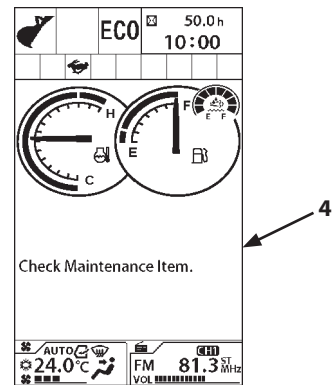

MDC1-01-213EN

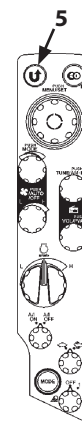

MDCD-01-026

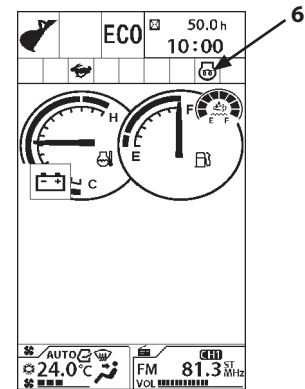

Basic Screen

MDC1-01-042

## OPERATING THE ENGINE

9. Release key switch (2) just after the engine has started. Key switch (2) will automatically return to the ON position.

**NOTE:**

- The engine speed will be kept to slow idle speed just after the engine starts. When engine speed control indicator (7) is displayed, slow idle speed will be maintained. When the coolant temperature or hydraulic oil temperature is low, the time will be longer. The engine speed will be kept to slow idle speed even if engine control dial (3) is not set in the slow idle position.
- After the slow idle speed is maintained, the warm-up system automatically operates and the engine speed will temporarily increase even if engine control dial (3) is set to the slow idle position.

**CAUTION:** Do not attempt to operate the machine when engine speed control indicator (7) is lit. The engine speed may change after the slow idle period and operation speed of work device may suddenly increase, which may cause a serious accident.

**NOTE:** White smoke may be emitted for several minutes after the engine start, this is not a malfunction.

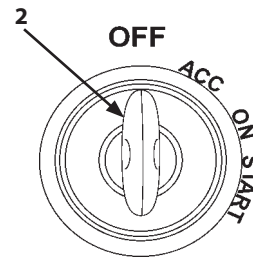

MDCD-01-030

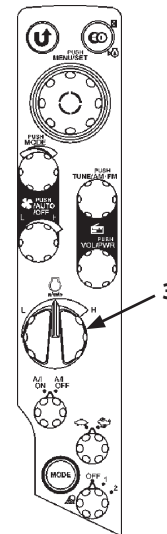

MDCD-01-026

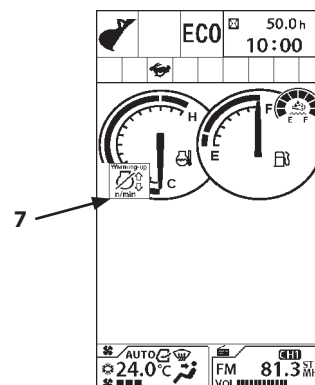

MDC1-01-355

## OPERATING THE ENGINE

### Starting in Cold Weather

#### Preheating

1. Confirm that pilot control shut-off lever (1) is in the LOCK position.
2. Turn engine control dial (3) to around the middle between the L and H position.
3. Sound the horn to alert bystanders.
4. Insert key (2) to the key switch. Turn it to ON position.
5. "Wait-screen (nothing is displayed)" is displayed on the monitor for 2 seconds. Regardless of pilot control shut-off lever (1) position, the engine can not be cranked during this moment.
6. When the Password Input screen is displayed on the monitor, input the password. Unless the numeric keypad function (ignition block system) is activated, this screen is not displayed.

**IMPORTANT:** When required to activate the numeric keypad function (ignition block system), consult your authorized dealer.

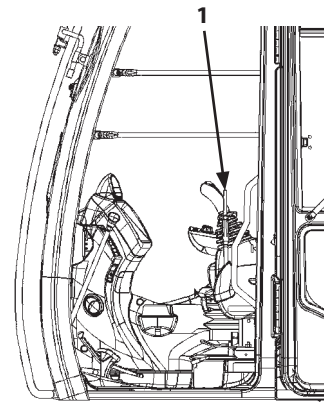

LOCK Position

MDCN-01-008

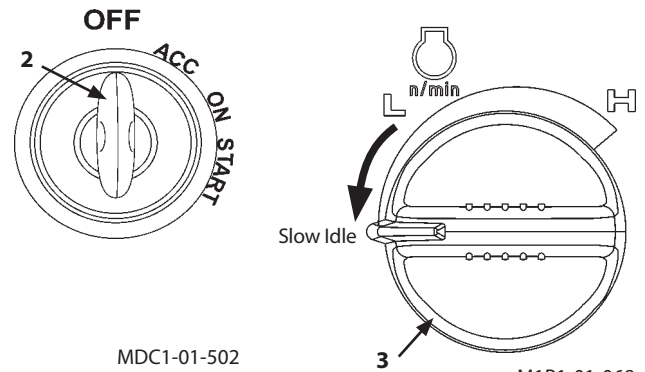

MDC1-01-502

M1P1-01-068

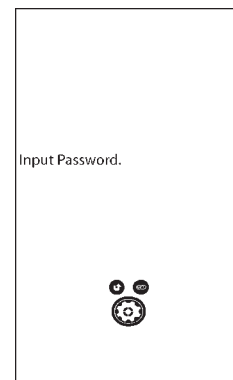

Password Input Screen

MDAA-01-085EN

## OPERATING THE ENGINE

 **NOTE:** When the key switch is turned ON, maintenance notification (4) for the item whose maintenance interval has expired displays for 10 seconds. Push Return to Previous Screen switch (5) or turn the pilot control shut-off lever to the UNLOCK position while the rear view camera is enabled to delete the notification.

7. The Basic Screen will be displayed on the monitor.  
The machine will automatically check if preheating is required or not. When preheating is required, preheat indicator (6) is lit for automatically.

 **NOTE:** In case, preheat indicator (6) does not come ON, preheating is not required. Follow the "Starting the Engine in Ordinary Temperature" section.

8. As soon as preheat indicator (6) goes OFF, turn key switch to START position to rotate the starter.

**IMPORTANT:** Never operate the starter for more than 10 seconds at a time. If engine fails to start, return key switch to OFF. Wait for more than 30 seconds, then try again. Failure to do so may cause damage to the starter and/or discharging the batteries.

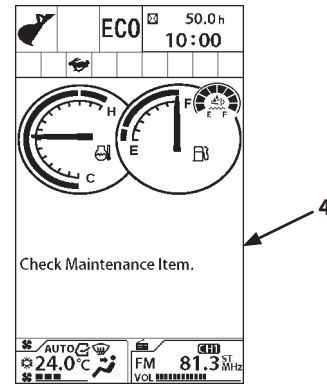

MDC1-01-213EN

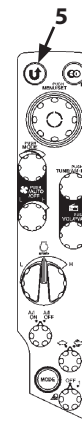

MDCD-01-026

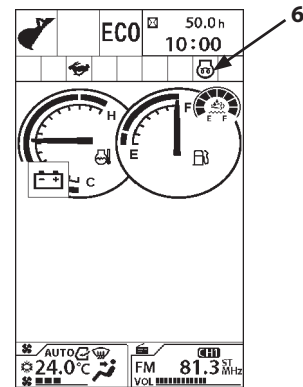

Basic Screen

MDC1-01-042

## OPERATING THE ENGINE

- Release key switch (2) just after the engine has started.  
Key switch (2) will automatically return to ON position.

**NOTE:**

- The engine speed will be kept to slow idle speed just after the engine starts. When engine speed control indicator (7) is displayed, slow idle speed will be maintained. When the coolant temperature or hydraulic oil temperature is low, the time will be longer. The engine speed will be kept to slow idle speed even if engine control dial (3) is not set in the slow idle position.
- The warm-up system automatically operates after keeping slow idle speed, and the engine speed will temporarily increase even if the engine control dial is set in the slow idle position.

**CAUTION:** Do not attempt to operate the machine when engine speed control indicator (7) is lit. The engine speed may change after the slow idle period and operation speed of work device may suddenly increase, which may cause serious accident.

**NOTE:** White smoke may be emitted for several minutes after the engine start, this is not a malfunction.

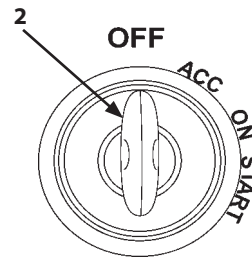

MDCD-01-030

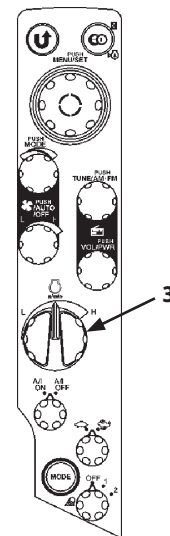

MDCD-01-026

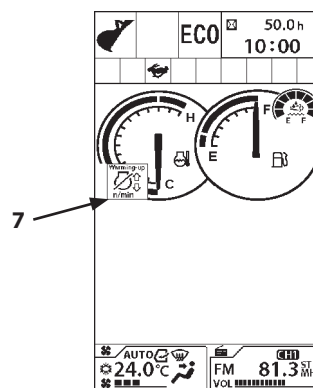

MDC1-01-355



## OPERATING THE ENGINE

### Check Instruments After Starting

#### Checking instruments through monitor functions

After starting the engine, check the following points through the monitor functions.

1. Check that alternator alarm indicator (1) is OFF. In case alternator alarm indicator (1) stays ON, immediately stop the engine. Inspect the alternator and battery system for any abnormality.
2. Check that engine oil pressure alarm indicator (2) is OFF and the alarm buzzer does not sound.

In case engine oil pressure alarm indicator (2) stays ON and the buzzer sounds, immediately stop the engine. Inspect the engine oil pressure system and the oil level.

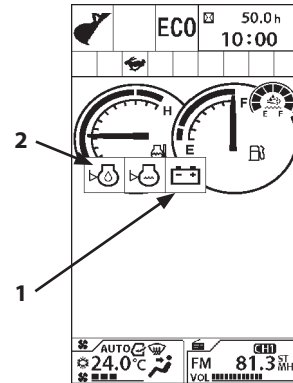

**IMPORTANT:** In case any abnormality is found on the monitor unit, immediately stop the engine. Inspect the cause of the problem.

MDC1-01-041

#### Check engine noise and exhaust gas color

Check that the engine noise and exhaust gas color is normal.

 NOTE:

- Check the exhaust gas color as follows. (After warm-up operation, run the engine with no loads.)
  - Clear : Normal (Perfect combustion)
  - Black : Abnormal (Imperfect combustion, abnormal aftertreatment device, abnormal fuel system)
  - White : Abnormal (Oil is leaking into the combustion chamber, abnormal aftertreatment device, abnormal fuel system)
- White smoke may be emitted for several minutes after the engine starts, this is not a malfunction.

## OPERATING THE ENGINE

### Using Booster Batteries

**IMPORTANT:** The machine electrical system is a 24 volt negative (-) ground. Use only 24 volt booster batteries with sufficient capacity.

**WARNING:**

- An explosive gas is produced while batteries are in use or being charged. Keep open flames and sparks away from the battery area. Do not continue to use or charge the battery when electrolyte level is lower than specified. Explosion of the battery may result.
- Park the machine and a machine with the booster batteries on a dry or concrete surface, not on steel plates. If the machine is parked on steel plates, dangerous sparks may be unexpectedly created on the machine.
- Never connect a positive terminal to a negative terminal, as a dangerous short circuit will occur.



SA-032

When the machine batteries are exhausted, start the engine using booster batteries as shown below.

#### Connecting the booster batteries cables

1. Stop the engine of the machine on which booster batteries are mounted.
2. Turn the battery disconnect switch to the OFF position.
3. Connect one end of red cable (1) to the positive (+) terminal of the machine batteries, and the other end to the positive (+) terminal of the booster batteries.
4. Turn the battery disconnect switch to the ON position.
5. Connect one end of black cable (2) to the negative (-) terminal of the booster batteries, and then make ground connection to the frame of the machine to be started with the other end of black (-) cable (2). In the last connection to frame, sparks may fly. Be sure to connect the cable end as far away from the machine batteries as possible.
6. After securely connecting the booster cables, start the engine of the machine on which booster batteries are mounted.
7. Start the engine of the machine with a problem.
8. After the engine starts, disconnect cables (2) and (1), following the procedure below.

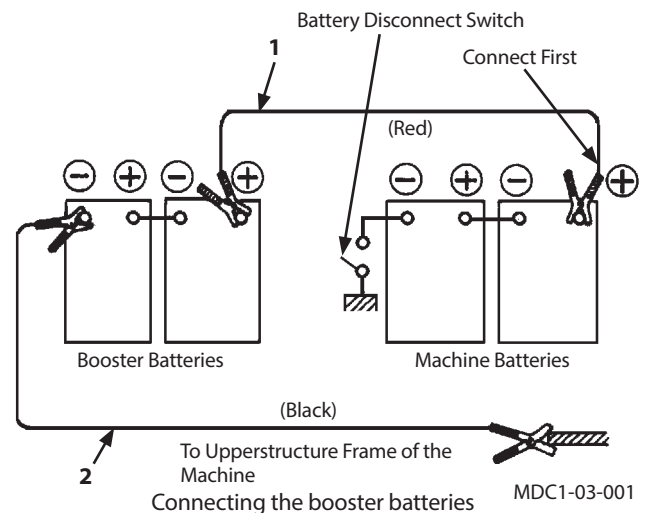

## OPERATING THE ENGINE

### Disconnecting the booster cables

1. Disconnect black negative (-) cable (2) from the machine frame first.
2. Disconnect the other end of black negative (-) cable (2) from the booster batteries.
3. Disconnect red positive (+) cable (1) from the booster batteries.
4. Disconnect red positive (+) cable (1) from the machine batteries.

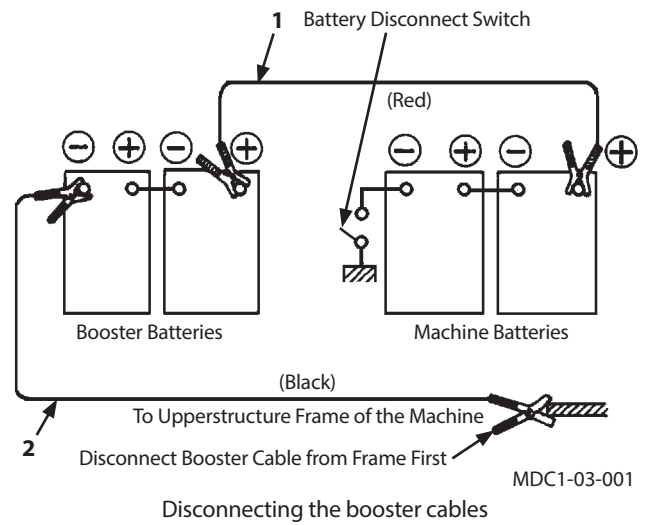

# OPERATING THE ENGINE

## Stopping the Engine

### Engine Stop Procedure

1. Except for special cases, before stopping the engine, lower the bucket and blade to the ground.
2. Pull pilot control shut-off lever (3) to LOCK position.
3. Turn engine control dial (1) to the slow idle position and run the engine for 5 minutes to cool the engine.

**IMPORTANT:** If the engine equipped with a turbocharger is stopped without first performing the cool down operation, the lubricant on the turbocharger bearing surfaces may desiccate due to the intense heat present inside the turbocharger, possibly causing damage to the turbocharger.

**Do not idle for excessively long periods.**

**Observe local and federal engine idling regulations.**

4. Turn key switch (2) OFF to stop the engine.

### If the engine does not stop, even if the key switch is turned to the OFF position. (Emergency Stop)

In case the engine does not stop even if key switch (2) is turned OFF due to failure of the machine, move engine stop switch (4) downward to stop the engine. The engine will stop. Return engine stop switch (4) to its original position (upward).

**CAUTION:** Do not use engine stop switch (4) unless absolutely necessary. When the machine stops due to machine failure, do not start the machine until repair is completed

**IMPORTANT:** The DEF/AdBlue® pump runs for a while after the engine stops to return DEF/AdBlue® from piping to the DEF/AdBlue® tank. Do not turn battery disconnect switch to the OFF position during this time. Otherwise, the Urea SCR system may be damaged.



SA-2590

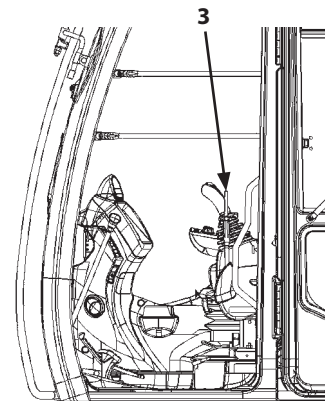

LOCK Position

MDCN-01-008

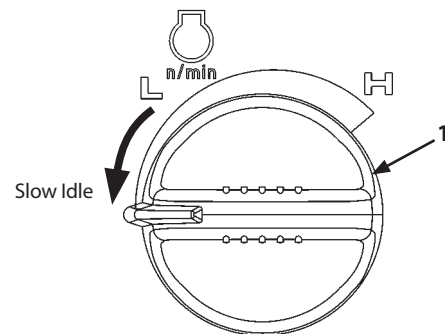

M1P1-01-068

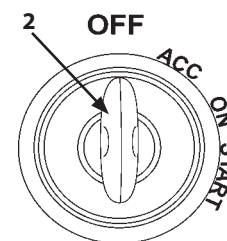

MDC1-01-502

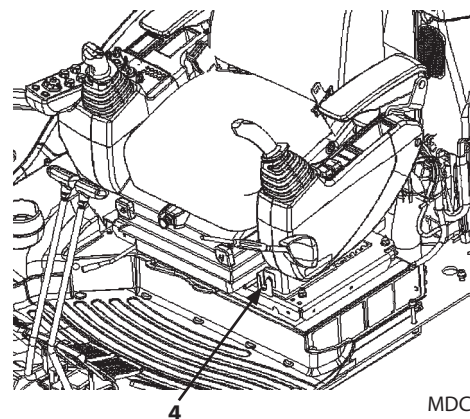

MDCN-01-004

## OPERATING THE ENGINE

### Engine Auto-Stop in Extremely Low Temperature

**WARNING:** This function automatically stops the engine. Take extra care on the work and work environment when using this function.

**IMPORTANT:** If the machine is left unoperated in an environment with temperatures under  $-20^{\circ}\text{C}$  or lower for a long period of time, exhaust gas particles may accumulate in the aftertreatment device, and may result in damage to the device.

In an environment with temperature of  $-20^{\circ}\text{C}$  or lower, the engine will automatically stop 60 minutes after the pilot control shut-off lever is pulled to the LOCK position. 30 seconds before the engine stop, the monitor displays "Engine Shut-down soon." message (1) and the indicator starts flashing. The buzzer sounds once 30 seconds before shut-down, and sounds continuously from 15 seconds. The engine speed decreases to idling speed, and then stops after 15 seconds. When the pilot control shut-off lever is pushed down before stopping the engine, the auto shut-down is disabled and the engine will not stop.

**IMPORTANT:** When the engine stops, turn the key switch to ACC or OFF once and then turn it to START to restart the engine. In the case the engine stops automatically, turn the key switch OFF before leaving the machine for a long period of time. Do not leave the machine after auto shut-down. Failure to do so may discharge the batteries.

**NOTE:** The engine can stop automatically when related conditions are met regardless of the auto shut-down function being ON or OFF.

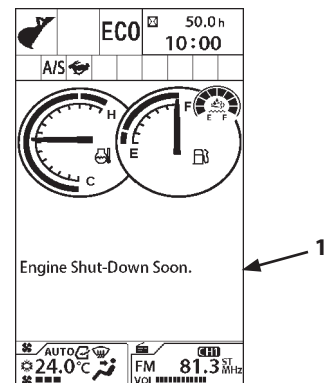

MDC1-01-146EN

# DRIVING THE MACHINE

## Travel Levers and Pedals

### Travel Operation

Travel operation of this machine is controlled by using levers and pedals.

**⚠ WARNING:** If the travel motors are located at the front of the machine, the machine will move in the reverse direction to that shown on the operation instruction decal. Normal travel operation is when the travel motor is at the rear, and the front idler is at the front of the machine.

**✎ NOTE:**

- An arrow-mark seal is stuck on the inside surface of the side frame to indicate the machine front direction.
- A travel lever damper is provided on this machine to ensure smooth travel operation. Therefore, the travel lever or pedal may become heavier in extreme cold (-20 °C or below). This is caused by increase in oil viscosity, not a malfunction.

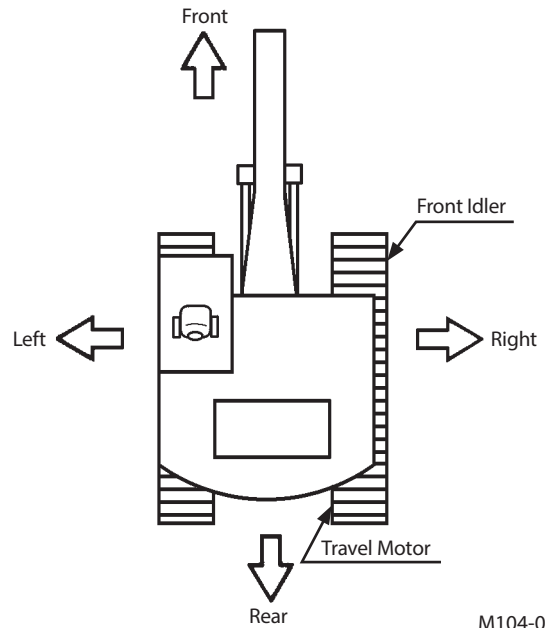

M104-01-038

- **Forward/Reverse Travel**  
Push down both left and right levers (or both pedals) frontward to travel the machine forward. Pull down the two levers (or pedals) rearward to travel the machine in reverse. Travel speed can be controlled by the operation stroke of the travel levers and pedals.
- **Ascend/Descend Slopes**  
Never attempt to ascend or descend slopes steeper than 35 degrees (70 %). Slowly operate the travel levers (or pedals) when descending a slope. When the travel levers are placed in the neutral position, brakes are automatically applied and the machine stops.

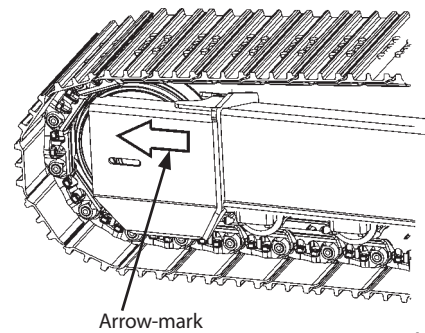

M178-03-001

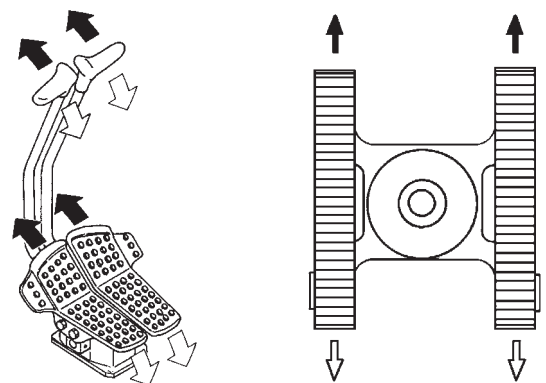

Forward/Reverse Travel

M104-04-009  
M104-04-003

## DRIVING THE MACHINE

- Pivot Turn

The machine direction is changed by driving one of two crawlers with either left or right travel levers (or pedals).

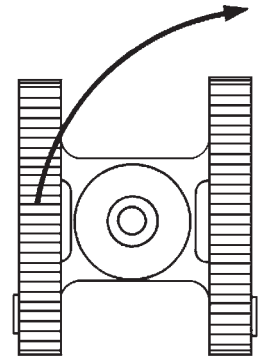
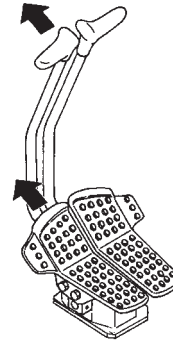

Pivot Turn

M104-04-010  
M104-04-005

- Spin Turn

The machine direction is changed by driving two crawlers in opposite direction at a time by operating one lever (or pedal) to forward and another lever (or pedal) to reverse.

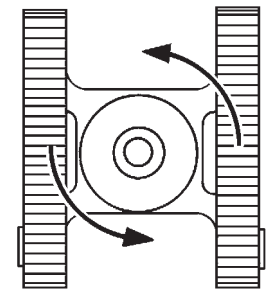
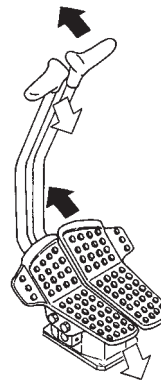

Spin Turn



M104-04-011  
M104-04-007



# DRIVING THE MACHINE

## Travel Mode Switch

**⚠ WARNING:** Tipping-over accidents can cause serious personal injury. Do not change travel mode switch (1) while traveling. In particular, changing to fast mode (2) while descending a slope is very dangerous. Always stop the machine before changing the travel speed mode.

Turn travel mode switch (1) on the switch panel to the specified position to select the travel mode (Fast/Slow).

- Fast Mode: Turn travel mode switch (1) to  mark (2) position.
- Slow Mode: Turn travel mode switch (1) to  mark (3) position.

-  Mark (Fast Speed Mode)
-  Mark (Slow Speed Mode)

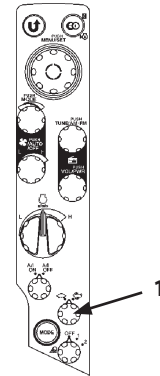

MDCD-01-026

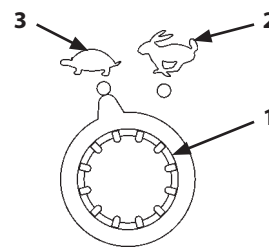

MDCD-01-028

## Travel Alarm (Optional)

During travel operation, the travel alarm sounds to warn the people near the machine that the machine is traveling.

### Deactivating Travel Alarm

More than 12 seconds after starting to travel the machine, raise the armrest and push travel alarm deactivation switch (4) to stop the travel alarm. (Within 12 seconds, the travel alarm deactivation switch is inoperable.)

Once the machine stops traveling and when restarting to travel, the travel alarm will sound again. If desired to stop the alarm, operate travel alarm deactivation switch (4) once more.

**✎ NOTE:** The optional switch locations differ depending on what kinds of optional devices are equipped. Before using the switches, make sure what kinds of optional devices are equipped.

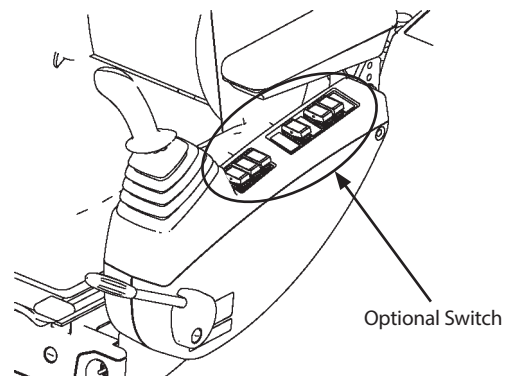

T1V1-05-02-004

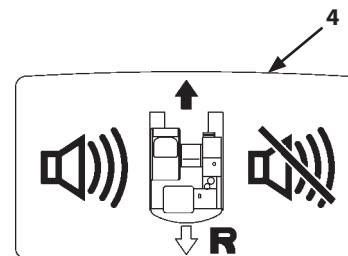

M1U1-01-035



## DRIVING THE MACHINE

### Operating on Soft Ground

Avoid traveling on very soft ground.

If traveling on soft ground is unavoidable, please carefully follow below.

- Travel only an area self-propelling is possible. And in case of any emergency, do not go into depth of retrieval impossible.
- If the machine becomes unable to travel, lower the bucket to a firm ground, and evacuate slowly by pulling the arm with machine raised by boom and arm. In this case, simultaneously operate the boom, arm and traveling lever to avoid excessive load to the machine. Refer to "Raising the Machine with Boom and Arm"
- If the machine becomes stuck or unable to travel due to the mud or dirt around the truck, raise one truck then another off the ground using the boom and arm, and rotate the raised track back and forth to remove the mud or dirt. Evacuate after the dirt and mud is removed.
- When it becomes unable to evacuate by machine itself, retrieve the machine with another machine. Be sure to attach the tow line correctly. (Refer to the "Retrieval" section.)



M104-05-012

### Raising the Machine with Boom and Arm

**WARNING:** Operate the machine carefully to avoid sideslip. Keep the angle of boom and arm between 90 to 110°.

1. Swing the upper structure 90°.
2. Make boom and arm angle to become boom and arm between 90 to 110° and lower the bucket to raise the track off ground.
3. Place blocks under machine frame to support the machine.

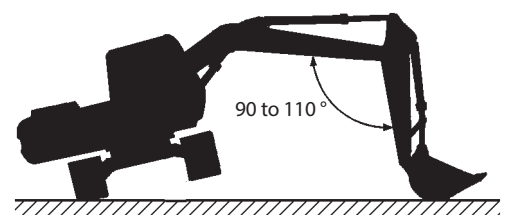
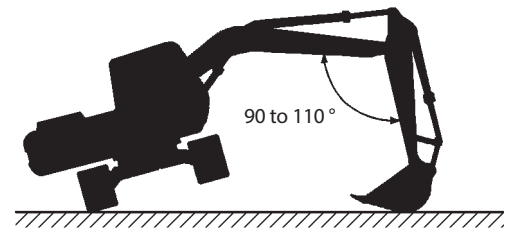

M104-05-013

**IMPORTANT:** Do not raise the machine using the bucket teeth with bucket cylinder in maximum extension when using the hoe bucket reversed. This may damage the pin by an excessive load to the pin around the bucket and bucket cylinder.



MZX5-04-003

## DRIVING THE MACHINE

### Retrieval

**CAUTION:** Cables, straps, or ropes can break causing serious injury. Do not tow the machine with damaged chains, frayed cables, slings, straps, or wire ropes. Always wear gloves when handling cable, straps or wire ropes.

When it becomes unable to evacuate from soft ground by machine itself, retrieve the machine with another machine by attaching the wire rope as shown. Be sure to attach the wire ropes around the track frames of both machines as shown. To prevent the wire ropes from being damaged, place protective material between the track frame and the wire ropes.

### IMPORTANT:

- Track frame has two shackle holes; The center shackle hole on the track frame is provided to pull lightweight objects. The shackle holes on the bottom of the track frame are used to secure the machine for transportation.
- Do not use these shackle holes on the track frame for retrieval the machine. This may damage the holes.
- Refer to the instructions on page 5-23 for using the center shackle hole appropriately.

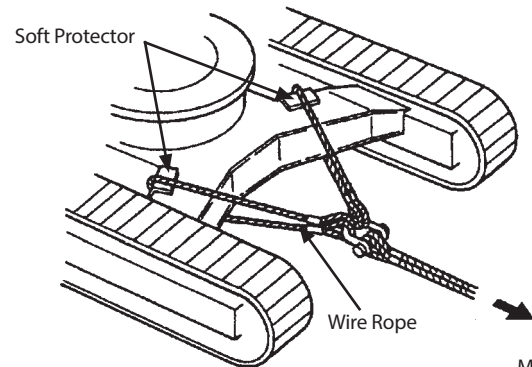

M104-05-010

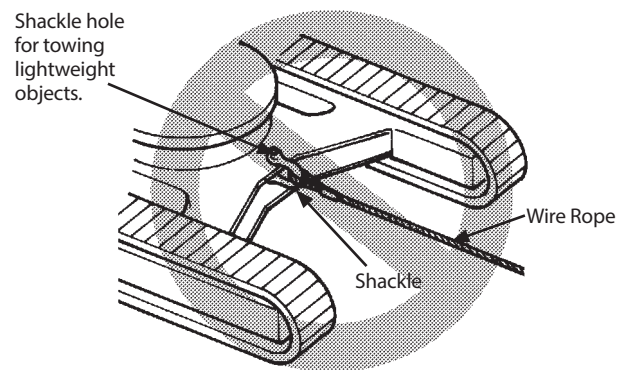

MZX5-04-004

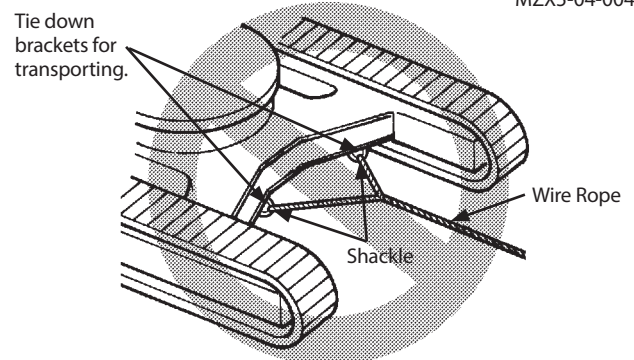

MZX5-04-005

## DRIVING THE MACHINE

### Operating in Water or Mud

The machine can be operated in water up to the upper edge of the upper rollers only if water is flowing slowly, and the worksite ground is firm enough to prevent the machine from sinking past the upper edge of the upper roller.

Frequently check the position of the machine when working in such conditions. Reposition the machine if necessary.

Avoid submerging the swing bearing, swing gears and center joint.

If the swing bearing, swing internal gear and center joint are submerged, remove the drain plug to drain mud and water. Clean swing area. Install plug. Lubricate swing internal gear and swing bearing.

#### Swing Internal Gear Capacity

ZX135US-6 : 9 L

ZX225USLC-6 : 17 L

ZX345USLC-6 : 19 L

Lubricate swing internal gear.

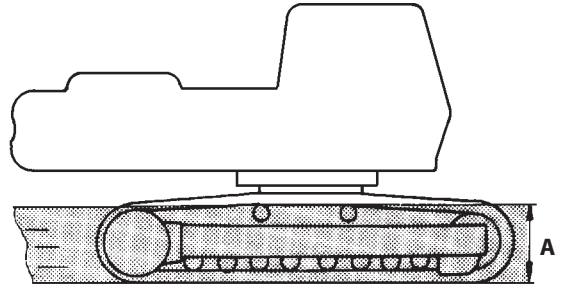

M104-05-009

Model	A
ZX135US-6	660 mm
ZX225USLC-6	770 mm
ZX345USLC-6	860 mm

## DRIVING THE MACHINE

### Parking the Machine on Slopes

**⚠ WARNING:** Avoid parking machine on slopes. The machine may tip over, possibly resulting in personal injury.

If parking the machine on a slope is unavoidable:

- Thrust the bucket teeth into the ground.
- Return the control levers to neutral and pull pilot control shut-off lever (2) to the LOCK position.
- Block both tracks.

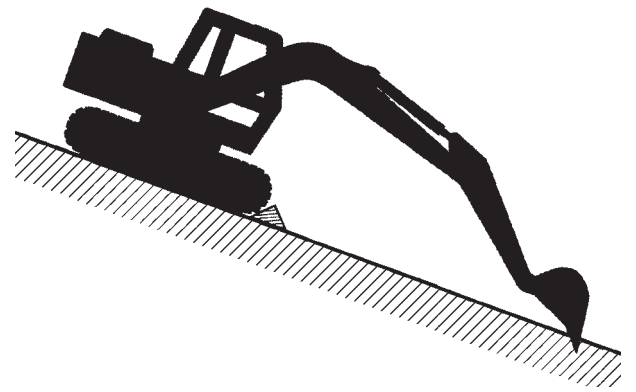

SA-2273

### Parking the Machine

1. Park the machine on a firm, level surface.
2. Lower the bucket and blade to the ground.
3. Turn the auto-idle switch off.

**IMPORTANT:** Turbocharger may be damaged if the engine is not properly shut down.

4. Turn engine control dial (1) counterclockwise fully to Slow Idle position. Run the engine for approximately 5 minutes to cool the engine.
5. Turn the key switch to OFF. Remove the key from the key switch.
6. Pull pilot control shut-off lever (2) to the LOCK position.

**IMPORTANT:** Protect cab electrical components from bad weather. Always close windows, roof vent and cab door when parking the machine.

7. Close windows, roof vent, and cab door.
8. Lock all access doors and compartments.

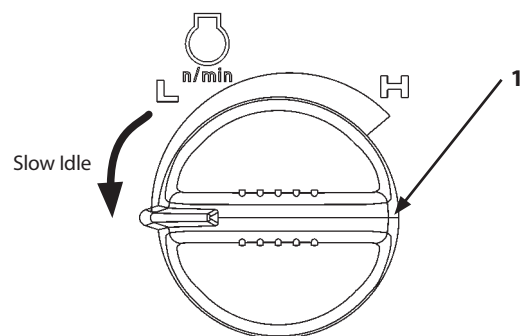

M1P1-01-068

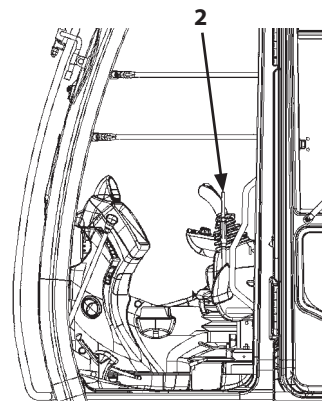

LOCK Position

MDCN-01-008

## DRIVING THE MACHINE

### Prohibition of Sudden Control Operations when Traveling at High Speed

When traveling at high speed, do not perform operations such as emergency stop.

Do not perform operations such as repeated switching between forward and reverse.

Repetition of these kinds of operation increases the load on rollers, front idler and travel device, and risks damaging internal parts of the machine and shortening their life.

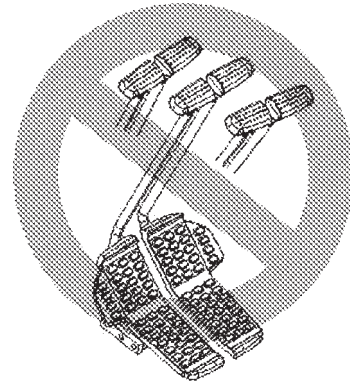

MJAQ-04-001

### Prohibition of Traveling for Long Periods

When the machine travels for a long period of time, the temperature of parts such as the rollers, front idler and travel device increases. This risks damage to internal seals, oil leakage and damage to other components.

If there is no option but to travel for an extended period, contact your authorized dealer.

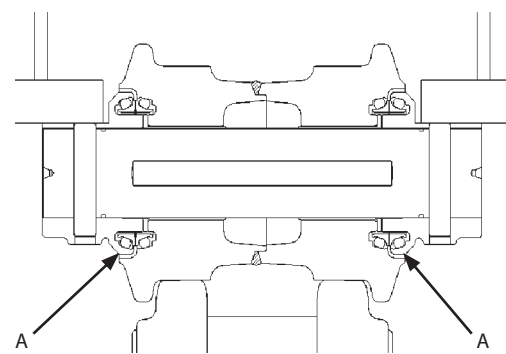

Lower Roller

MDFY-04-001

A- Location at risk of oil leakage

## OPERATING THE MACHINE

### Control Lever (ISO Pattern)

#### **⚠ WARNING:**

- **Never extend any part of body beyond window bars or frame, as it could be crushed, if boom control lever is accidentally bumped or otherwise engaged.**

**Never remove the window sash bar.**

- **Make sure you know the location and function of each control before operating.**
- **Do not change the operation pattern of the control lever. Failure to do so may result in mistaken operation of the machine.**

A label showing the control patterns of the levers and pedals is attached on the right side in the cab.

When a lever is released, it will automatically return to neutral, and that machine function will stop.

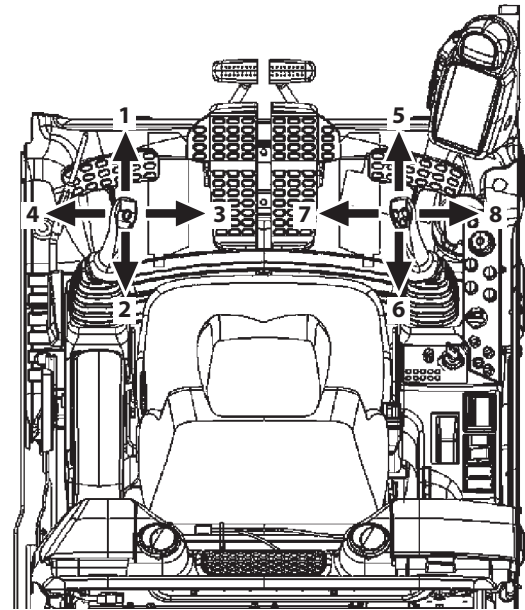

MDCN-01-002

- 1- Arm Roll-Out
- 2- Arm Roll-In
- 3- Swing Right
- 4- Swing Left
- 5- Boom Lower
- 6- Boom Raise
- 7- Bucket Roll-In
- 8- Bucket Roll-Out

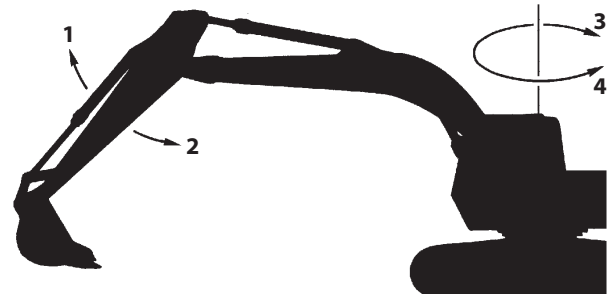

M104-05-001

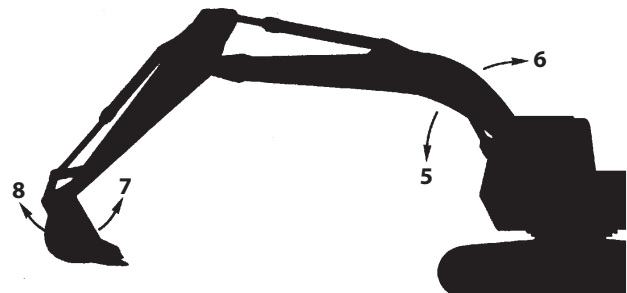

M104-05-002

## OPERATING THE MACHINE

### Pilot Control Shut-Off Lever

Pilot control shut-off lever (1) functions to prevent misoperation of the machine if control levers and pedals are accidentally moved when leaving the operator's seat or when entering the cab.

**⚠ WARNING:** Always pull pilot control shut-off lever (1) into the full LOCK position. Unless pilot control shut-off lever (1) is fully moved to the LOCK position, the control levers are not locked, possibly creating a hazardous situation. When leaving the machine, always stop the engine. Pull pilot control shut-off lever (1) up to the LOCK position. Always check to be sure that pilot control shut-off lever (1) is pulled up to the LOCK position before transporting the machine or leaving the machine at the end of a shift.

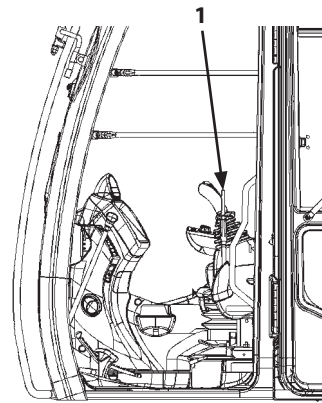

LOCK position

MDCN-01-008

### Before Leaving the Machine

1. Park the machine on a firm, level surface. Lower the bucket to the ground. Return all control levers to neutral. Properly shut down the engine.
2. Pull pilot control shut-off lever (1) up into the full LOCK position.

### Before Starting Operation:

Confirm that pilot control shut-off lever (1) is pulled up to the LOCK position before starting the engine. The engine will not start if the pilot control shut-off lever (1) is in any other position than LOCK.

Slowly push down pilot control shut-off lever (1) to the UNLOCK position before starting operation.

Confirm that all control levers and pedals are in neutral and that no part of the machine is in motion.

**⚠ WARNING:** If any part of the machine (any actuator) moves when pilot control shut-off lever (1) is lowered to the UNLOCK position despite when all controls are in neutral, the machine is malfunctioning. Immediately pull pilot control shut-off lever (1) back to the LOCK position, and stop the engine. See your authorized dealer.

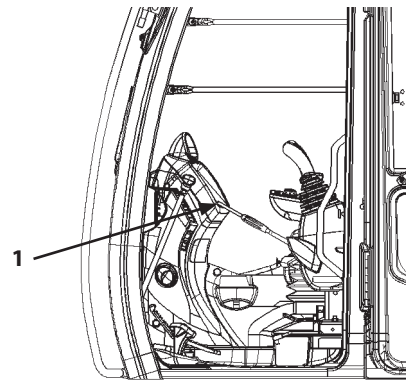

UNLOCK Position

MDCN-01-009

## OPERATING THE MACHINE

### Warming-Up Operation

In cold weather, warm up the machine until coolant and hydraulic oil temperature increases to the appropriate operating temperature.

#### IMPORTANT:

- The appropriate hydraulic oil operating temperature on this machine is 50 to 80 °C. Hydraulic components may be seriously damaged if the machine is operated with low temperature hydraulic oil. If warming up the machine by relieving the relief valve, continuously relieve the relief valve for 10 to 15 seconds then pause for 5 to 10 seconds.
- When the hydraulic oil temperature is 5 °C or lower, the pump torque is restricted to protect the engine.

1. Even after engine starts, leave engine control dial (1) in the slow idle position.  
(Do not operate the machine until the needle of coolant temperature gauge (2) starts swinging.)
2. After the needle of coolant temperature gauge (2) starts swinging, turn engine control dial (1) to approx. Medium position.
3. Operate the boom, arm and bucket cylinders slowly to each stroke end several times. If the machine is equipped with various attachments, operate the attachment function slowly to allow hydraulic oil to circulate through the system.
4. Operate the travel and swing functions slowly to allow hydraulic oil to circulate through the systems.
5. Warming-up operation ends after the above operation is completed.

#### NOTE:

- The engine speed will be kept to slow idle speed just after the engine starts. When engine speed control indicator (3) is displayed, slow idle speed will be maintained. When the coolant temperature or hydraulic oil temperature is low, the time will be longer. The engine speed will be kept to slow idle speed even if engine control dial (1) is not set in the slow idle position.
- The warm-up system automatically operates after keeping slow idle speed, and the engine speed will temporarily increase even if engine control dial (1) is in the slow idle position.

**CAUTION:** Do not attempt to operate the machine when engine speed control indicator (3) is lit. The engine speed may change after the slow idle period and operation speed of work device may suddenly increase, which may cause a serious accident.

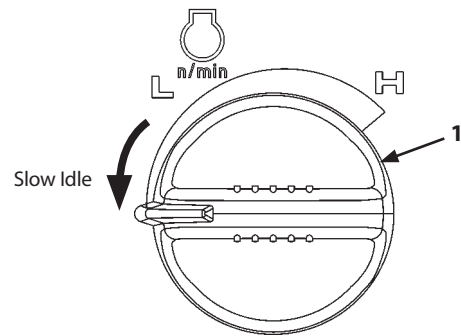

M1P1-01-068

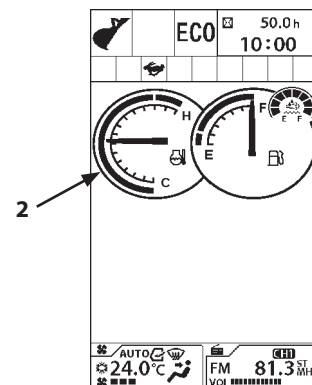

MDC1-01-001

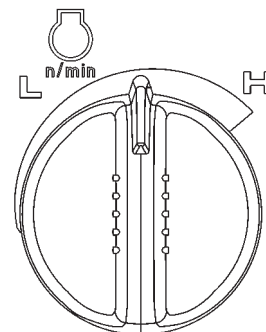

M1P1-05-003

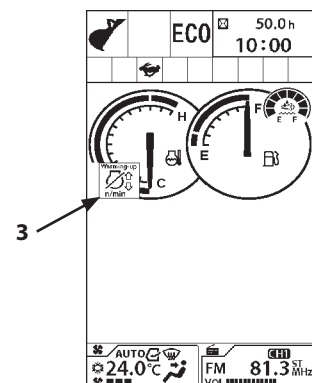

MDC1-01-355



# OPERATING THE MACHINE

## Engine Speed Control

Increase and decrease the engine speed using engine control dial (1) located on the switch panel, as illustrated.

- Turn engine control dial (1) clockwise to increase the engine speed. Turn engine control dial (1) counterclockwise to decrease the engine speed.
- Note that the auto-idle function will be deactivated if engine control dial (1) is operated while the engine is running at the auto-idle setting.
- Before stopping the engine, always turn engine control dial (1) counterclockwise to the stop (to the slow idle setting). Run the engine five minutes to cool the engine. Then, turn the key switch to OFF position to stop the engine.

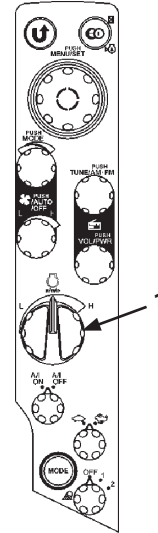

MDCD-01-026

### NOTE:

- The engine speed will be kept to slow idle speed just after the engine starts. When engine speed control indicator (3) is displayed, slow idle speed will be maintained. When the coolant temperature or hydraulic oil temperature is low, the time will be longer. The engine speed will be kept to slow idle speed even if engine control dial (1) is not set in the slow idle position.
- The warm-up system automatically operates after keeping slow idle speed, and the engine speed will temporarily increase even if engine control dial (1) is set in the slow idle position.

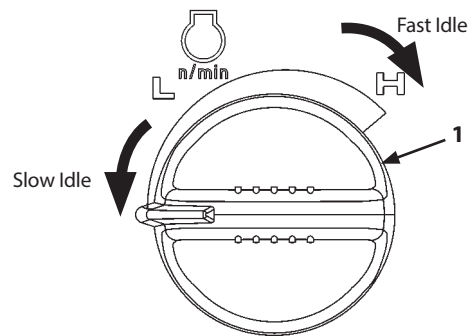

M1P1-01-068

** CAUTION:** Do not attempt to operate the machine when engine speed control indicator (3) is lit. The engine speed may change after the slow idle period and operation speed of the work device may suddenly increase, which may cause a serious accident.

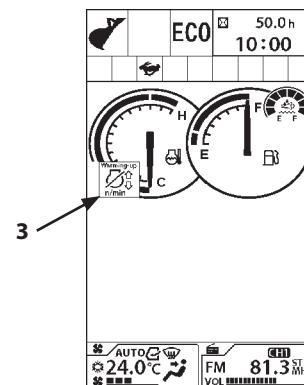

MDC1-01-355

# OPERATING THE MACHINE

## Auto-Idle

### Auto-Idle Function

When auto-idle switch (3) is turned to the A/I ON position, approximately 4 seconds after all control levers are returned to neutral, the engine speed decreases to the auto-idle setting to save fuel consumption.

The engine speed will immediately increase to the speed set by engine control dial (2) when any control lever is operated.

### IMPORTANT:

- Always check if auto-idle indicator (1) is turned ON or OFF before starting operation. If indicator (1) is ON, the auto-idle function will be activated.
- Always be aware of the setting of engine control dial (2) when auto-idle switch (3) is turned to the A/I ON position. If the engine speed is set high with engine control dial (2), and the operator is not aware of the high engine speed setting, the engine speed will unexpectedly increase when any control lever is operated, causing the machine to move unexpectedly, possibly resulting in serious personal injury.

**WARNING:** Prevent the machine from moving unexpectedly. Be sure to turn auto-idle switch (3) to the A/I OFF position when unexpected machine movement is undesirable, especially when loading/unloading the machine for transportation.

### NOTE:

- Auto-idle control may not work completely until the end of the warm-up.
- The auto-idle control function does not operate when the aftertreatment device is regenerating.

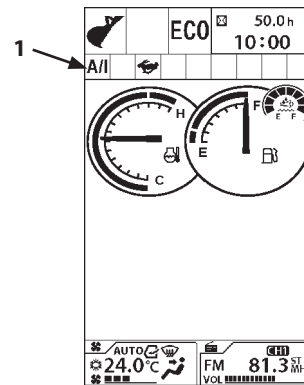

MDC1-01-314

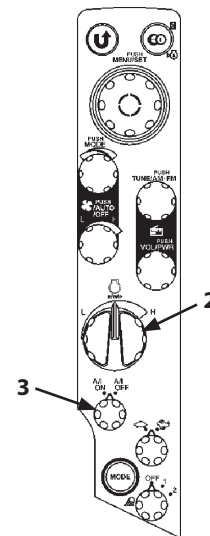

MDCD-01-026

## OPERATING THE MACHINE

### Auto-Idle ON/OFF

Note that the auto-idle function can be turned ON or OFF by using auto-idle switch (3) only when the key switch is in ON position.

Always check if the auto-idle function is turned ON or OFF with auto-idle indicator (1).

Auto-Idle Indicator (1) ON : Auto-Idle Function ON  
Auto-Idle Indicator (1) OFF : Auto-Idle Function OFF

- When auto-idle switch (3) is turned OFF with auto-idle indicator (1) ON, indicator (1) will go OFF and the auto-idle system is deactivated.
- The auto-idle system is not deactivated even if the engine is stopped by turning the key switch with auto-idle switch (3) in the A/I ON position [indicator (1) ON]. When the engine is restarted, the auto-idle system remains activated, allowing auto-idle indicator (1) to flash for 5 seconds and stay ON later.

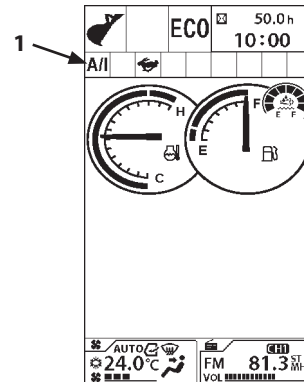

MDC1-01-314

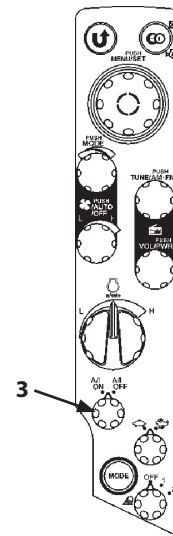

MDCD-01-026

## OPERATING THE MACHINE

### Auto Shut-Down

**WARNING:** This function automatically stops the engine. Take extra care on the work and work environment when using this function.

When the auto shut-down function is turned ON, the engine automatically stops after the preset time at the state in which the pilot control shut-off lever is pulled. 30 seconds before the engine stop, monitor screen (2) displays "Engine Shut-Down Soon." message and indicator (1) starts flashing. Also the buzzer sounds. The buzzer sounds once at 30 seconds before, and continuously sounds from 15 seconds. The engine speed decreases to the idling speed, and then stops after 15 seconds. When the pilot control shut-off lever is pushed down before stopping the engine, the auto shut-down is disabled and the engine will not stop.

**IMPORTANT:** Check whether the status of auto shut-down indicator (1) is ON or OFF. If indicator (1) is ON, the auto shut-down function will be activated.

#### Operating Condition

- The engine is running.
- The pilot control shut-off lever is in the LOCK position.
- Coolant and hydraulic oil temperature are not high.
- The aftertreatment device is not in the process of manual regeneration.

#### IMPORTANT:

- When the engine is stopped by the auto shut-down function, turn the key switch to ACC or OFF once and then turn it to START to restart the engine. Turn the key switch OFF after auto shut-down when leaving the machine for long period of time. Do not leave the machine after auto shut-down. Failure to do so may discharge the batteries.
- When the key switch is turned to the OFF position while the auto shut-down function is ON, the setting will be reset. When required to keep the setting, consult your authorized dealer.

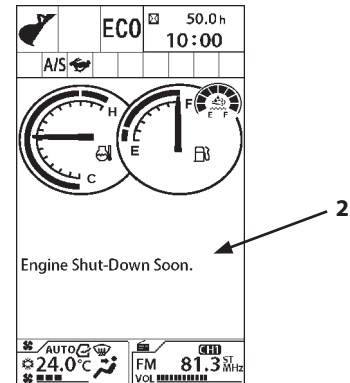

MDC1-01-146EN

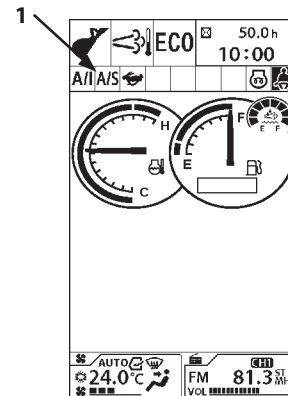

MDC1-01-286

# OPERATING THE MACHINE

## IMPORTANT:

- Even if the auto shut-down function is ON, the engine will not stop during manual regeneration of the aftertreatment device.
- When the auto shut-down activates, the air conditioner will also stop.

## Setting the Auto Shut-Down Function

### Auto Shut-Down: On/Off

1. Push selector knob (2) while displaying Basic Screen (1) to display Main Menu screen (3).
2. Rotate selector knob (2) to highlight Setting Menu (4).
3. Push selector knob (2) to display Setting Menu screen (5).
4. Rotate selector knob (2) to highlight Auto Shut-Down (6).

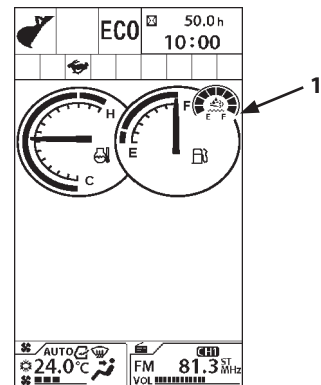

MDC1-01-001

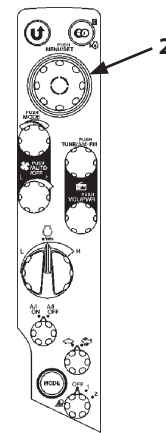

MDCD-01-026

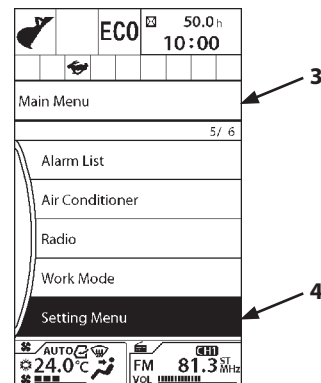

MDAA-01-114EN

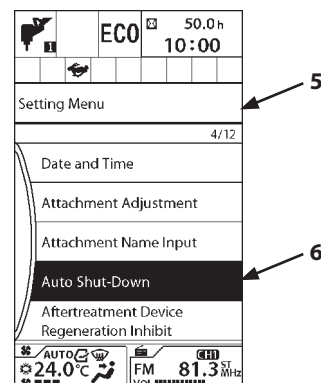

MDC1-01-147EN

## OPERATING THE MACHINE

- Push selector knob (2) to display Auto Shut-Down screen (7).

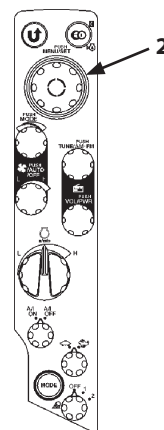

MDCD-01-026

- Rotate selector knob (2) to highlight ON (8).
- Push selector knob (2) to turn the Auto Shut-Down function ON. Push selector knob (2) again to turn the auto shut-down function OFF.

 **NOTE:** When the function is ON, the mark "■" is displayed in green. When the function is OFF, the mark "■" is displayed in gray.

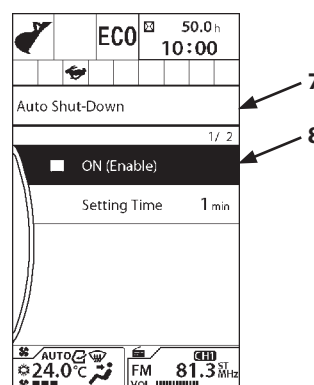

MDAA-01-148EN

### Setting Time of Auto Shut-Down

- On the Auto Shut-Down screen, rotate selector knob (2) to highlight Setting Time (9).
- Push selector knob (2). Rotate selector knob (2) to adjust the auto shut-down setting time.
- Push selector knob (2) to make the change.

 **NOTE:** 30 seconds before the engine stop, the monitor will display "Engine Shut-Down Soon." message (10).

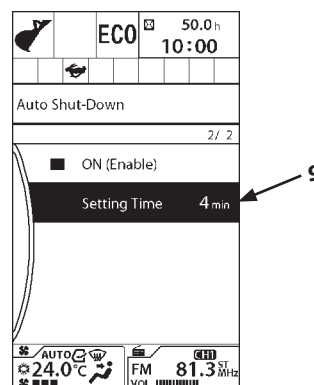

MDAA-01-150EN

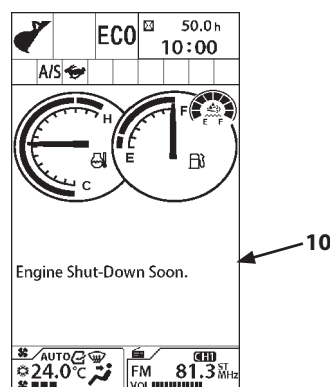

MDC1-01-146EN

# OPERATING THE MACHINE

## Aftertreatment Device Manual Regeneration

### Manual Regeneration Procedure

When the manual regeneration is needed, screen (1) as shown on the right side will be displayed. When screen (1) is displayed, you need to perform the manual regeneration. Before starting the manual regeneration, be sure to check the following.

If the machine is equipped with a rear view camera, and the camera is enabled, screen (1) is displayed only when the pilot control shut-off lever is in LOCK position.

- No person is present around the machine
- Keep flammable materials away from the aftertreatment device.
- Fuel level alarm does not light.
- DEF/AdBlue® level alarm does not light.

1. Park the machine in a safe place. Lower the front attachment onto the ground.
2. Pull the pilot control shut-off lever to the LOCK position.
3. Set the engine control dial to slow idle.
4. Push aftertreatment device manual regeneration switch (2).
5. When pushing aftertreatment device manual regeneration switch (2), screen (3) as shown on the right side will be displayed and the manual regeneration starts. Bar graph on screen (3) indicates progress of the regeneration process.

**IMPORTANT: The manual regeneration does not start unless the pilot control shut-off lever is in the LOCK position and the engine control dial is in slow idle. When touching the pilot control shut-off lever or the engine control dial during manual regeneration, the regeneration process is aborted. When the process is aborted, start over again.**

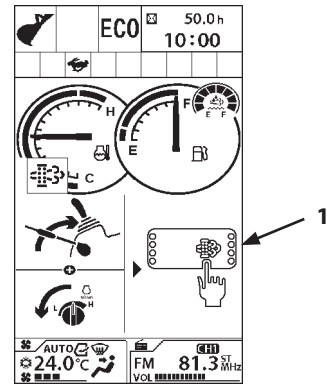

MDC1-01-005

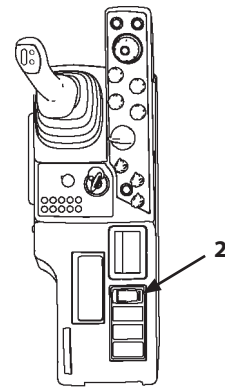

MDC1-01-543

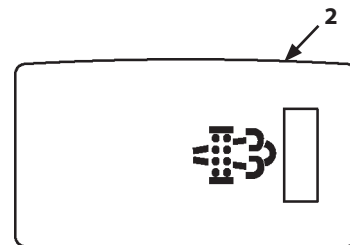

MDAA-05-002

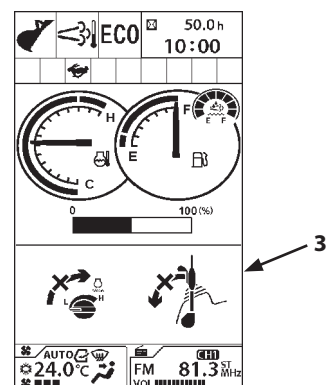

MDC1-01-006

## OPERATING THE MACHINE

6. When the manual regeneration is finished, "Regeneration Has Completed." message will be displayed. If "Regeneration Has Failed." message is displayed, start the manual regeneration process again. Regeneration process may fall in conditions other than those mentioned above (such as sensor malfunction or low ambient temperature).

### NOTE:

- The engine sound may change and the engine speed may increase when the manual regeneration starts, this is not a malfunction.
- Regeneration time varies depending on the ambient temperature.
- White smoke may temporarily be generated from the tail pipe during the regeneration process, this is not a malfunction.
- Manual regeneration time is shorter directly after machine operation, and longer when engine temperature is low.
- Coolant temperature may increase during the manual regeneration.

### IMPORTANT:

- **If regeneration must be interrupted, push the manual regeneration switch again. The message "Regeneration Has Failed." will be displayed on the monitor, but the machine becomes operable. In this case, manual regeneration should be performed again. Restart manual regeneration as soon as possible.**
- **Depending on the working and environmental conditions, there may be occasions when the effectiveness of the catalyst within the aftertreatment device decreases and replacement becomes necessary. If warm up is finished, ordinarily a manual regeneration will take around 15 to 30 minutes to complete. If the regeneration takes over 40 minutes, contact your nearest authorized dealer to arrange an inspection.**

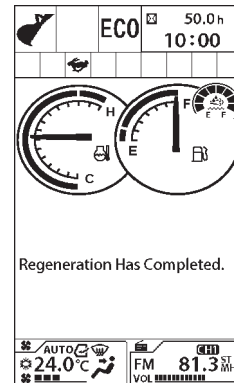

MDC1-01-083EN

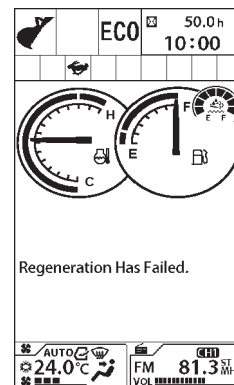

MDC1-01-084EN



## OPERATING THE MACHINE

---

### Work Mode

Select Work Mode in the main menu, and select the appropriate hydraulic circuit and pump flow rate for the front attachment at Work Mode screen.

When the engine is started, the digging mode is automatically set. The following 6 work modes can be selected from the Work Mode screen.

- Digging Mode
- Breaker 1 Mode
- Breaker 2 Mode
- Pulverizer 1 Mode
- Crusher 1 Mode
- Grapple 1 Mode

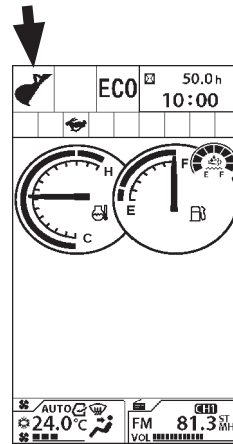













MDC1-01-001

## OPERATING THE MACHINE

The selected work mode is indicated by attachment mode indicator (2) on Basic Screen (1).

Select the work mode corresponding to the work in which the machine is engaged, referring to the table below.

	Work Mode	Description
	Digging Mode	Select this mode when using bucket.
	Breaker 1 to 5 Mode	Select this mode when using breaker.
	Pulverizer 1 to 5 Mode	Select this mode when using pulverizer.
	Crusher 1 to 5 Mode	Select this mode when using crusher.
	Vibrating Hammer 1 to 5 Mode	Select this mode when using vibrating hammer.
	Grapple 1 to 5 Mode	Select this mode when using grapple.
	Clamshell 1 to 5 Mode	Select this mode when using clamshell.
	Thumb 1 to 5 Mode	Select this mode when using thumb.
	Tilting Rotator 1 to 5 Mode	Select this mode when using tilting rotator.
	Tilting Bucket 1 to 5 Mode	Select this mode when using tilting bucket.
	Others 1 to 5 Mode	Select this mode when other than the above attachment is used.

 **NOTE:** 51 work modes shown above are designated as standard specifications. Up to 11 attachment modes other than digging mode can be designated. Consult your authorized dealer for adding or changing the designation of the attachment modes.

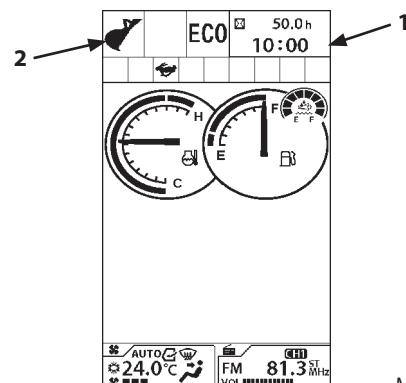

MDC1-01-001

# OPERATING THE MACHINE

## Attachment Selection

1. Push selector knob (2) while displaying Basic Screen (1) to display Main Menu screen (3).
2. Rotate selector knob (2) to highlight Work Mode (4).
3. Push selector knob (2) to display Work Mode screen (5).
4. Rotate selector knob (2) to highlight the Desired Front Attachment.  
(In the right example, "Bucket" (6) is highlighted.)
5. Push selector knob (2) to make the changes.

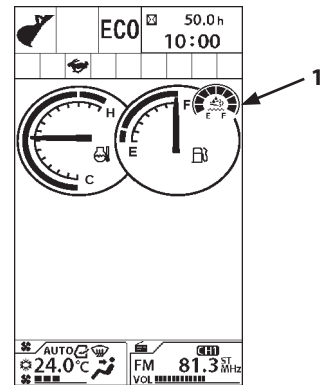

MDC1-01-001

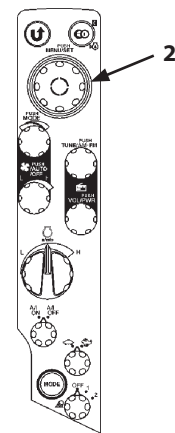

MDCD-01-026

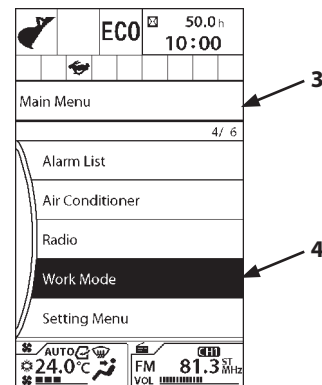

MDAA-01-100EN

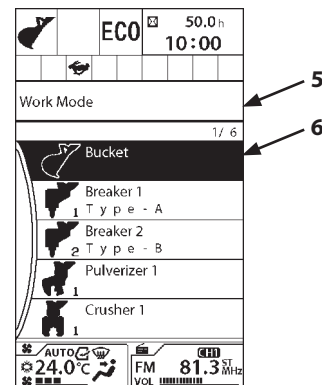

MDAA-01-101EN

## OPERATING THE MACHINE

---

### Power Boost Switch

Power boost switch (4) is located on the top of the right control lever.

When power boost switch (4) is pushed, increased front attachment power will be supplied for about 8 seconds.

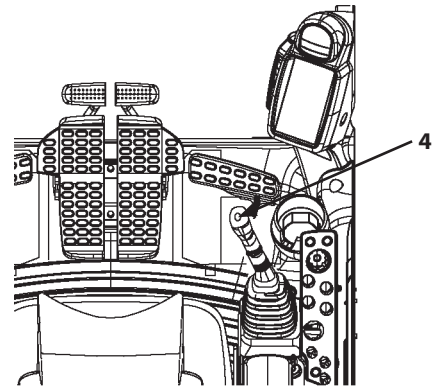

MDAA-01-344

# OPERATING THE MACHINE

## Power Mode

Two engine speed modes, ECO or PWR mode is selected by operating power mode switch (1).

### ECO (Economy) Mode

Operate the machine in this mode when performing normal work.

ECO is displayed on Power Mode Display (2).

### PWR (Power) Mode

Use PWR (Power) mode when extra horsepower is needed.

PWR is displayed on Power Mode Display (3).

### H/P (High Power) Mode

Use the H/P mode (4) when extra fast speed and/or heavy duty work is needed.

 **NOTE:** ECO mode is set automatically when starting the engine. Set PWR mode if necessary.

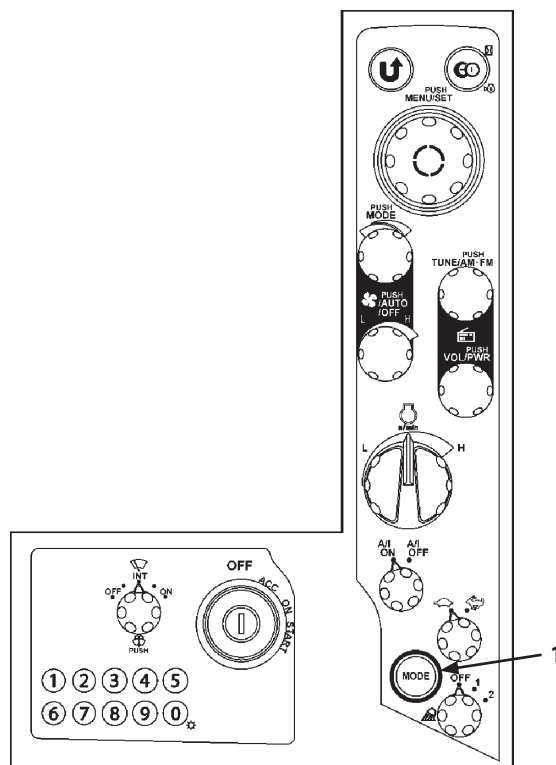

MDCD-01-027

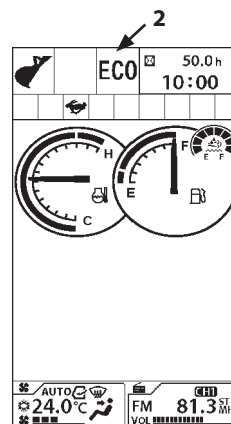

MDC1-01-001

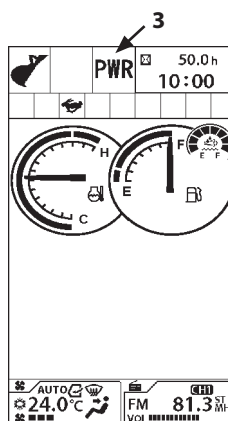

MDC1-01-353

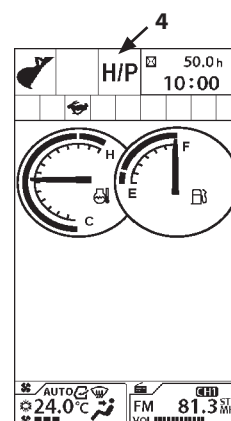

MDA1-01-357

## OPERATING THE MACHINE

---

### Operating Backhoe

- Use the appropriate arm and bucket for the work. (Refer to the "Bucket Types and Applications" in the Specifications chapter.)
- Pull the bucket toward the machine using the arm as the main digging force.
- When soil sticks to the bucket, remove it by moving the arm and/or bucket rapidly back and forth.
- Place the bucket teeth on the ground with the bottom of the bucket at a 45 degree angle to the ground.
- When trenching a straight line, position the tracks parallel to the trench. After digging to the desired depth, move the machine as required to continue the trench.
- When operating front attachment with some room left before the stroke end of the cylinder.

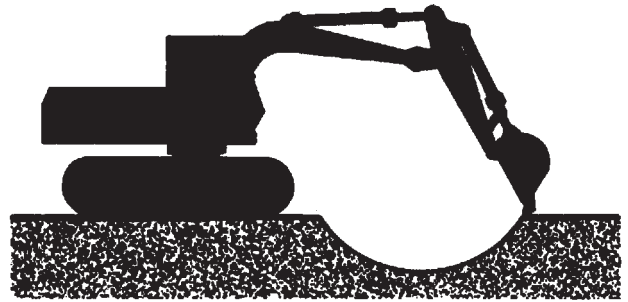

M107-05-037

#### IMPORTANT:

- **When digging at an angle, avoid striking the tracks with the bucket teeth.**
- **Lower the boom smoothly. Avoid stopping suddenly as this may impact the machine.**
- **When digging a deep excavation, avoid striking the boom or bucket cylinder hoses against the ground.**
- **When operating the machine with the blade (if equipped) positioned towards the front, the bucket teeth may come in contact with the blade.**

## OPERATING THE MACHINE

### Shovel

Backhoe operation digs the ground using the bucket in a roll-in motion. Face shovel operation digs the ground using the arm cylinder in a scraping motion.

**WARNING:** Take care not to hit the cab when rolling in the arm with a reversed-installed bucket.

**IMPORTANT:** If a bucket hook is mounted, take care not to hit the arm with the hook when rolling in the bucket.

- For face shovel operation, dig the ground using the arm cylinder in a scraping motion.
- When underground water is expected, make a slope angle of 2 to 3° to drain this water as shown.

**NOTE:** Because of the hydraulic cylinder structure, digging force of the face shovel operation is smaller than for backhoe operation.



MZX5-05-003

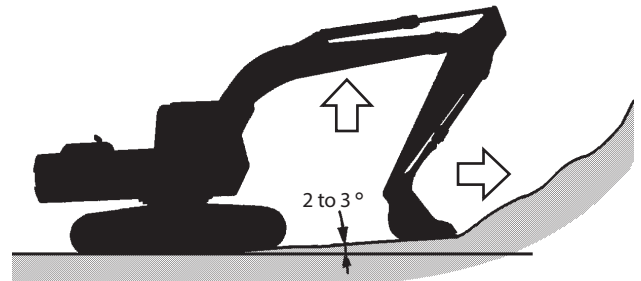

M104-05-020

## OPERATING THE MACHINE

---

### Grading Operation

Operate the boom, arm, and the bucket in such a way so that the bucket teeth move horizontally, constantly keeping them perpendicular to the ground at the grading operation.

**IMPORTANT: Do not pull or push dirt with the bucket when traveling. Excess force will be applied on each part, and the machine may be damaged.**

1. Operate arm roll-in function while slowly raising the boom. Once the arm moves past the vertical position, slowly lower the boom to allow the bucket to maintain a smooth surface.
2. Reverse the directions in step 1 to perform arm roll-out operation.
3. Perform slope finishing work using the same procedure described in steps 1 and 2.

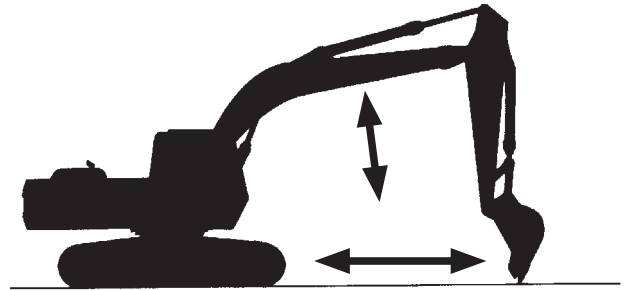

M104-05-017



## OPERATING THE MACHINE

---

### Do Not Strike the Ground with Bucket Teeth

**⚠ WARNING:** Forcibly striking the bucket teeth on the ground may result in personal injury from flying debris. It will also shorten the service life of each part on the front attachment.

If the bucket teeth are forcibly struck on the ground, it shortens the service life of the front attachment parts (especially the bucket).

When digging a hard gravel layer, use the upwards digging force of the bucket. Operate the boom, arm and the bucket simultaneously so that the bucket teeth efficiently bite into the ground.

Flying debris may result in personal injury.

### Avoid Hammer Work

**⚠ WARNING:** As the bucket body has a curved surface, hammer work or piling work is very dangerous. Doing so may damage the bucket and front attachment.

Do not attempt to use the bucket for hammer work and piling work.

Doing so may damage the bucket and front attachment, causing personal injury.



MZX5-05-004

## OPERATING THE MACHINE

---

### Avoid Abusive Operation

Do not attempt to add additional digging force by using travel, raising the rear of the machine to use the machine's weight.

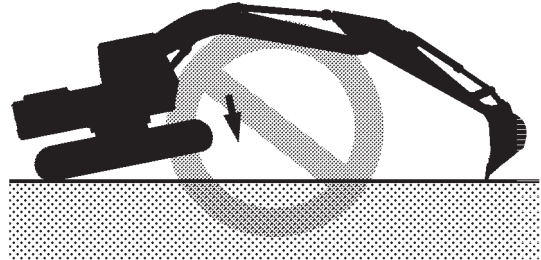

MZX5-05-005

### Never Move an Object Sideways with the Bucket

For example, do not swing the bucket to level material or do not strike objects sideways with the bucket. Doing so may damage the front attachment and the swing system.



MZX5-05-006

## OPERATING THE MACHINE

---

### Retracting the Arm and Bucket

Pay attention to the following when installing cab equipment (optional) such as OPG (level 2) front guard, OPG (level 2) head guard, rain visor, cab top lights (4 lights), etc.

**⚠ CAUTION:** When the machine is equipped with the cab equipment mentioned above, the teeth of the bucket may hit the cab equipment if the arm is retracted excessively. Be careful not to hit the cab equipment with the teeth of the bucket when retracting the arm.



### Do Not Use Wide Track Shoes on Rough Ground

Never use wide track shoes on rough ground such as rocks, sand or gravel. Wide track shoes are designed for soft ground.

Failure to do so may result in shoe bending and/or shoe bolt loosening, and may damage other undercarriage components such as track link and rollers.

(Refer to the "Shoe Types and Applications" in the Specifications chapter.)

M107-05-072

## OPERATING THE MACHINE

### Shackle Hole Usage

A shackle hole is provided on the track frame to tow light weight objects.

**IMPORTANT:** Be sure to conform to the restrictions and precautions stated below when towing a light weight object using the shackle hole provided on the track frame. The track frame and/or the shackle hole may be damaged otherwise.

- The maximum drawbar pull is as below.

Model	Maximum Drawbar Pull
ZX135US-6	44100 N (4500 kgf) or less
ZX225USLC-6, 345USLC-6	73600 N (7500 kgf) or less

- Be sure to use a shackle.
- Keep the tow line horizontal, straight, and parallel to the tracks.

Select the slow travel mode. Slowly drive the machine when towing.

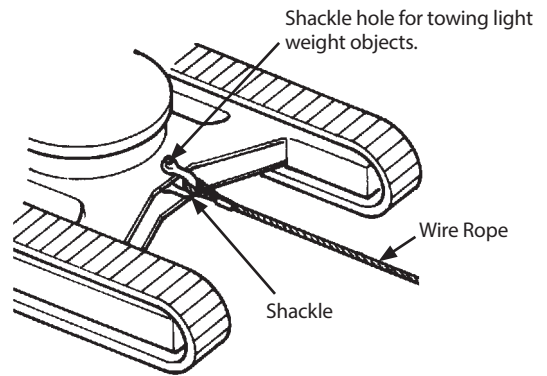

M104-05-011

## OPERATING THE MACHINE

### Pilot Accumulator Functions (Optional)

Pilot accumulator (1) is a pressure storage reservoir of the control circuit which supplies pressure and enables operation of the control circuit even after stopping the engine. The front attachment can be lowered using the control lever and the weight of the attachment itself, and pressure in the hydraulic circuit can be released after stopping the engine.

#### Pressure Release Procedure of Hydraulic Circuit

1. Set the machine in the parking position.
2. Pull the pilot control shut-off lever to the LOCK position.

Perform items from 3 to 5 within 15 seconds.

As the pressure in pilot accumulator (1) gradually decreases after stopping the engine, pressure in the hydraulic circuit can be released for few seconds after stopping the engine.

3. Stop the engine. Turn the key switch ON.
4. Push the pilot control shut-off lever to the UNLOCK position.
5. Move the control levers and attachment pedals forward and rearward or left and right to release pressure from the hydraulic circuit.
6. Pull the pilot control shut-off lever to the LOCK position and turn the key switch OFF.

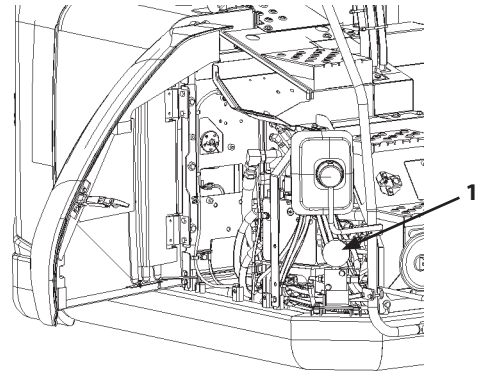

ZX135US-6

MDCN-05-001

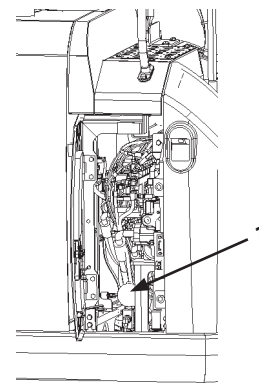

ZX225USLC-6

MDCN-05-002

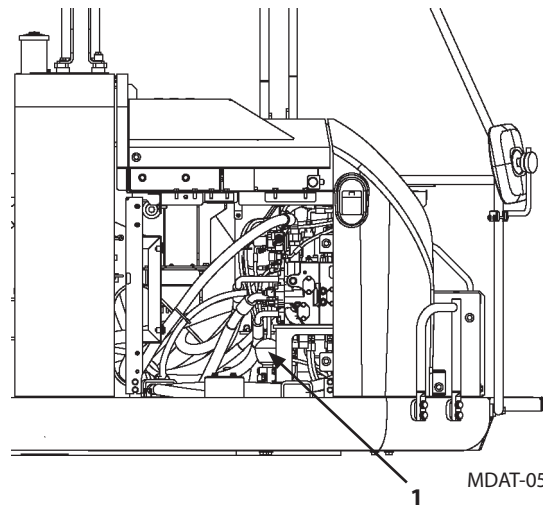

ZX345USLC-6

MDAT-05-001

## OPERATING THE MACHINE

### How to Lower Boom in Case of Emergency and When Engine Stops

#### (Without hose-rupture safety valve)

**⚠ WARNING:** Prevent personal injury. Confirm that no one is under the front attachment before starting the procedure below.

In case the engine suddenly stops and the engine cannot be restarted, lower the boom by following the procedure below.

**IMPORTANT:** Never loosen screw (2) more than 2 turns. Screw (2) may come off.

1. Loosen lock nut (1) in the emergency valve on the right. Loosen screw (2) one half of a turn. The boom lowering speed can be partly adjusted by loosening screw (2) further.

**IMPORTANT:** Excessive leakage may result if screw (2) and lock nut (1) are tightened insufficiently. Be sure to retighten screw (2) and lock nut (1) to specifications.

2. After the boom is lowered, tighten screw (2) and tighten lock nut (1) to the specifications below.

Locknut (1)

Tightening Torque: 13 N·m (1.3 kgf·m)

Screw (2)

Tightening Torque: 7 N·m (0.7 kgf·m)

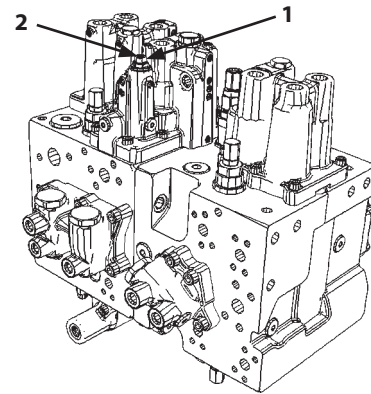

ZX135US-6

MDAA-05-008

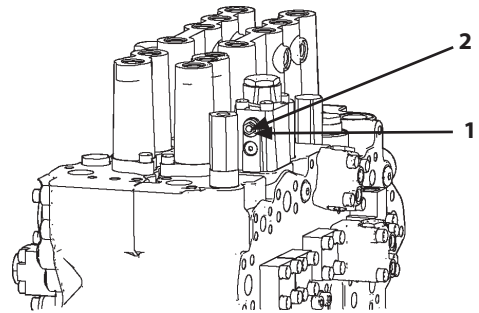

ZX225USLC-6, 345USLC-6

MDAA-05-003

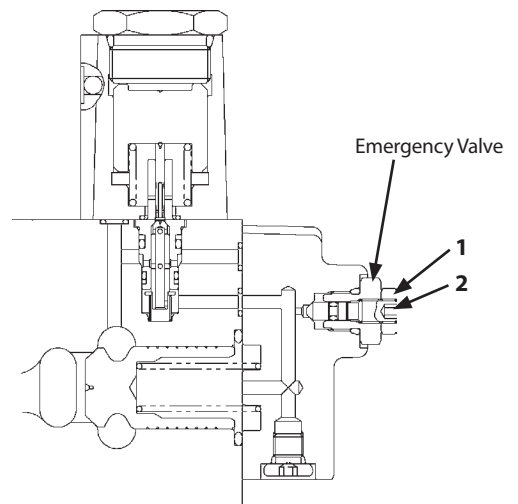

T1V1-03-03-038

## OPERATING THE MACHINE

---

### Precautions for After Operations

- After finishing the day's operation, drive the machine to a firm, level ground where no possibility of falling stones, ground collapse, or floods are present.  
(Refer to the section "PARKING THE MACHINE" in the DRIVING THE MACHINE chapter.)
- Fully refill the fuel in the fuel tank.  
Fully refill the DEF/AdBlue® in the DEF/AdBlue® tank.
- Clean the machine.

# TRANSPORTING

## Transporting by Road

When transporting the machine on public roads, be sure to first understand and follow all local regulations.

- When transporting the machine using a trailer, check the width, height, length and weight of the trailer with the machine loaded. Note that transporting weight and dimensions may vary depending on the type of shoe or front attachments installed.
- Investigate conditions on the route to be traveled in advance, such as dimensional limits, weight limits, and traffic regulations.

In some cases it may be necessary to obtain permission from the local authority concerned, or to disassemble the machine to bring it within local regulation for dimensional or weight limits.

Notify your authorized dealer that you are transporting the disassembled machine.

**IMPORTANT: Remove the auxiliary bar when transporting the machine. After transporting the machine, install the auxiliary bar in the operation position before operating the machine.**



M1V1-06-001

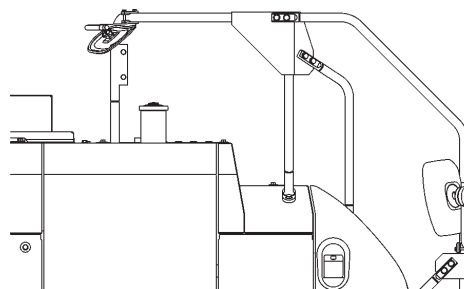

Transportation Position  
ZX225USLC-6

MDAT-06-005

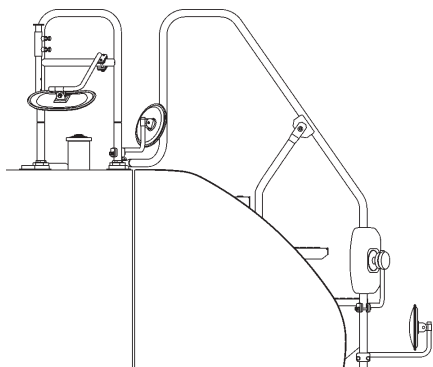

Transportation Position  
ZX135US-6

MDAT-06-003

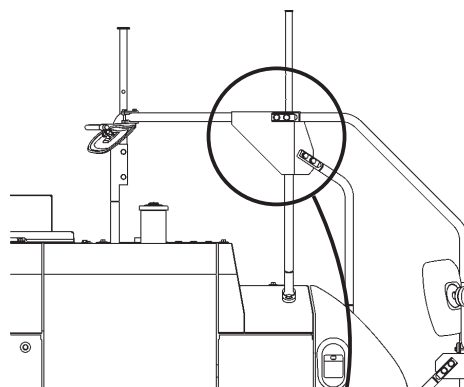

Operation Position  
ZX225USLC-6

MDAT-06-006

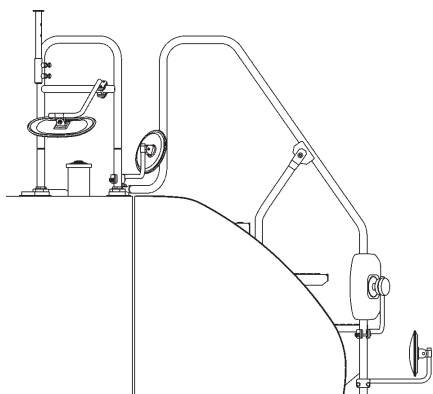

Operation Position  
ZX135US-6

MDAT-06-004

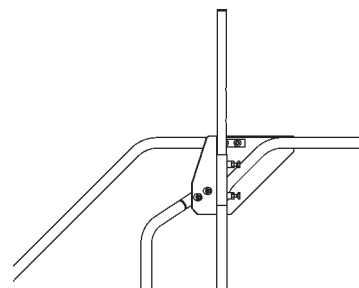

ZX135US-6, ZX225USLC-6

MDAT-06-007



## TRANSPORTING

---

### Loading/Unloading on a Trailer

Always load and unload the machine on a firm, level surface.

**⚠ WARNING:** Be sure to use a loading dock or a ramp for loading/unloading. Never use the front attachment functions when loading or unloading the machine.

#### Ramp/Loading Dock:

1. Before loading, thoroughly clean the ramps, loading dock and flatbed. Dirty ramps, loading docks, and flatbeds with oil, mud, or ice on them are slippery and dangerous.
2. Place blocks against the truck and trailer wheels while using a ramp or loading dock.
3. Ramps must be sufficient in width, length, and strength. Be sure that the incline of the ramp is less than 15 degrees.
4. Loading docks must be sufficient in width and strength to support the machine and have an incline of less than 15 degrees.
5. When loading a machine equipped with a pad crawler or rubber pad shoes, take sufficient care not to allow the machine to slip since the surface of the rubber pad shoe is flat.

Only load the machine after removing soil or clay adhered to the machine.

6. When transporting a machine equipped with a blade, take care not to hit the blade.

## TRANSPORTING

### Loading/Unloading

#### WARNING:

- Always turn the auto-idle switch OFF when loading or unloading the machine. In auto-idle mode, speed may automatically increase.
- Always select slow speed mode with the travel mode switch.
- Never steer while driving up or down a ramp, it is extremely dangerous and may cause the machine to turnover. NEVER attempt to change direction when positioned on the ramp. If repositioning is necessary, first move back to the ground or flatbed, change the direction of travel, and begin to drive again.
- At the point where the ramp meets the level surface there is a sudden change of angle. Take care when traveling over this point, as balance may be lost.
- Extreme care must be taken when swinging the upper structure when the machine is on the trailer flatbed. If the front attachment is fitted, swing slowly with the arm fully rolled-in underneath the boom, being careful not to lose the balance of the machine.

### Loading

#### CAUTION: In cold weather, be sure to warm up the machine before loading or unloading it.

If the front attachment is fitted, load with the front attachment faced towards the front, if the front attachment is not fitted, reverse onto the trailer.

1. Load the machine so that the centerline of the machine aligns with the centerline of the trailer flatbed.
2. Drive the machine onto the ramp slowly.

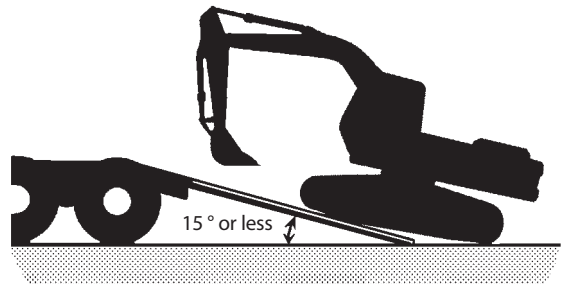

M1G6-06-002

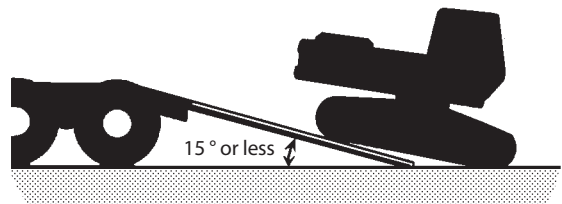

M107-06-018

## TRANSPORTING

---

### 3. When the front attachment is fitted

- 3.1 Determine a position for the bucket in line with the trailer. Adjust the angle of the boom and the arm at 90 to 110°.
  - 3.2 Lower the bucket onto to the deck of the trailer before the machine passes over the end of the ramp for support.
  - 3.3 Lift the bucket slightly off the deck of the trailer after the machine has moved to the designated space. With the arm lifted inwards, slowly swing the upper structure place around 180°.
  - 3.4 Rest the front attachment on supports such as wooden blocks placed on the trailer flatbed. Also lower the blade onto the deck at this time (if fitted).
4. Stop the engine. Remove the key from the key switch.
  5. Pull the pilot control shut-off lever to the LOCK position.
  6. Close cab windows, roof vent and door, and cover the exhaust opening, to prevent entry of wind and water. Place a cover over the exhaust outlet. Lock all doors, covers and caps if they have a lock.
  7. Store all mirrors and the radio antenna correctly.

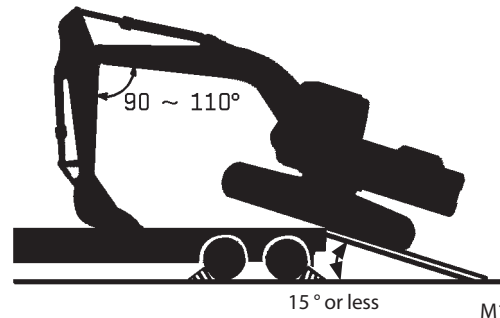

M107-06-012



M107-06-013

## TRANSPORTING

### Fastening Machine for Transporting

**⚠ WARNING:** Fasten the machine frame to the deck securely with chains and cables. While traveling, loads may shake around, move forward or backward or to the sides.

1. Place cog stoppers or blocks in front of and behind the tracks to help secure the machine.
2. Fasten each corner of the machine and front attachment to the trailer with appropriate strength of chains or cables.



M1V1-06-001

Without using the tie down bracket:

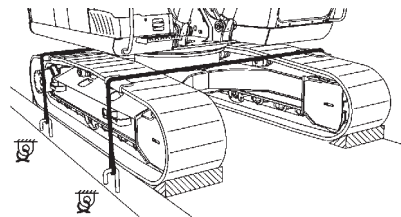

MDCD-06-001

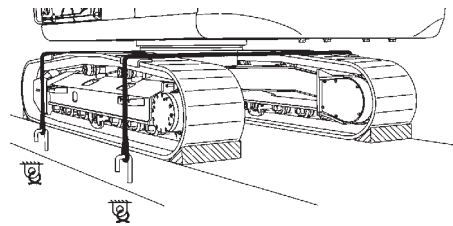

MDCD-06-002

Using the tie down bracket:

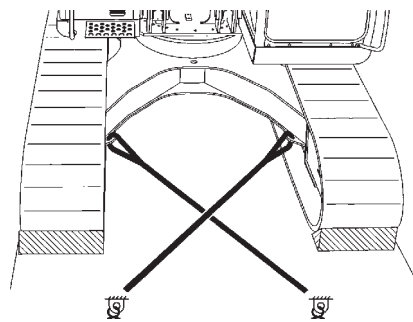

MDCD-06-003

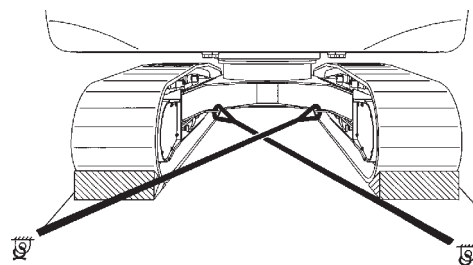

MDCD-06-004

## TRANSPORTING

### Unloading

**WARNING:** At the point where the ramp meets the level surface there is a sudden change of angle. Take care when traveling over it.

**IMPORTANT:** Make sure that the angle of the boom and the arm is kept between 90 to 110 ° when unloading the machine.

**Damage to the machine is possible if the arm is kept in a suspended state during unloading.**

1. Travel extremely slowly with the bucket on the ground and the angle of the arm and the boom kept at between 90 to 110 ° when moving from the edge of the trailer onto the ramp.

**IMPORTANT:** When driving the machine over the ramp, do not allow the machine to hit the ground with the arm too hard. Possible damage to the hydraulic cylinders may result.

2. The bucket must be on the ground before the machine begins to tip forward.
3. As the machine moves forward, raise the boom and extend the arm until the machine is completely off the ramp.

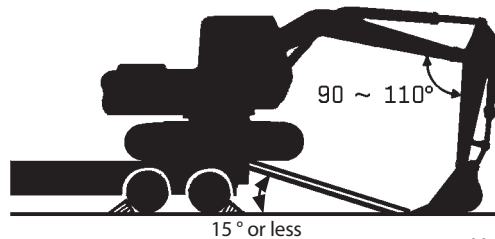

M107-06-014

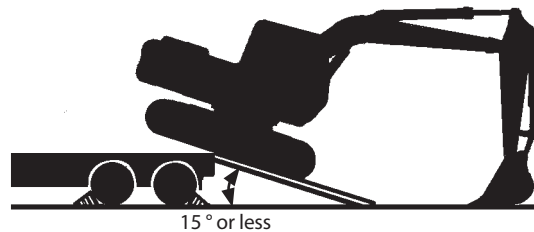

M107-06-015

## TRANSPORTING

---

### Lifting Machine

 **WARNING:**

- Use lifting cables and other lifting tools that are sufficient strong, and free from any damage and/or other defect.
- Consult your authorized dealer for correct lifting procedures, and the size and types of lifting cable and tools.
- Pull the pilot control shut-off lever to the LOCK position so that the machine does not accidentally move while being lifted.
- Incorrect lifting procedure and/or incorrect wire rope attachment will cause the machine to move (shift) while being lifted, resulting in machine damage and/or personal injury.
- Do not lift the machine quickly. Excessive load will be applied to the lifting wire ropes and/or lifting tools, possibly causing them to break.
- Do not allow anyone close to, or underneath the lifted machine.
- The indicated gravity center is for the standard specification machine. The center of gravity will vary depending on the kinds of attachments and/or optional equipment installed and their positioning. Take care not to lose the balance of the machine while lifting.

## TRANSPORTING

### Lifting

1. Fully extend the arm and bucket cylinders. Lower the boom until the bucket comes in contact with the ground.
2. Pull the pilot control shut-off lever to the LOCK position.
3. Stop the engine. Remove the key from the key switch.
4. Close and lock all doors and covers.
5. Use wire ropes and support bar of sufficient length so that they do not come in contact with the machine while lifting.

Wrap some protectors around wire ropes and/or support bar as required to prevent the machine from being damaged.

6. Set a crane in an appropriate position.
7. Thread the wire rope through and under both sides of the track frames as illustrated. Attach the wire ropes to the crane.

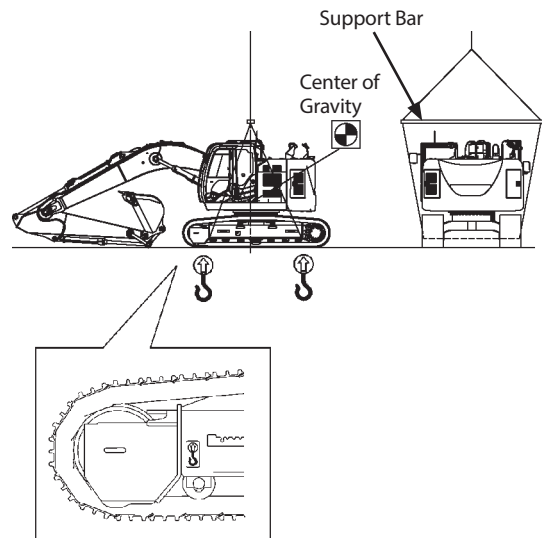

MDAT-06-009

## MAINTENANCE

---

### Correct Maintenance and Inspection Procedures

Learn how to service your machine correctly. Follow the correct maintenance and inspection procedures shown in this manual.

Inspect machine daily before starting.

- Check controls and instruments.
- Level, leakage and contamination of coolant, fuel, DEF/AdBlue® and hydraulic oil
- Check for leaks, kinked, frayed or damaged hoses and lines.
- Walk around machine checking general appearance, noise, heat, etc.
- Check for loose or missing parts.

If there is any problem with your machine, repair it before operating or contact your authorized dealer.

#### IMPORTANT:

- **Use only specified fuel, DEF/AdBlue®, lubricants and coolant.**
- **Be sure to use only genuine Hitachi parts. Failure to do so may result in serious injury or death and/or machine breakdown.**
- **Failure to use recommended fuel, lubricants, and genuine Hitachi parts will result in loss of Hitachi product warranty.**
- **Never adjust engine governor or hydraulic system relief valve.**
- **Protect electrical parts from water and steam.**
- **Never disassemble electrical components such as main controller, sensors, etc.**
- **Never adjust parts of engine fuel system or hydraulic equipment.**
- **Using bad quality fuel, drainage agent, fuel additives, gasoline, kerosene or alcohol refueled or mixed with specified fuel may deteriorate performance of fuel filters and cause sliding problem at lubricated contacts in the injector. It also affects the engine and aftertreatment device parts, leading to malfunction.**
- **Using bad quality DEF/AdBlue® may deteriorate performance of the engine and affect the aftertreatment device, leading to malfunction. Using improper density DEF/AdBlue® may derate the engine power.**
- **Use Hitachi genuine high performance filter.**



SA-005



## MAINTENANCE

---

- **Body Information Controller**

This machine provides a body information controller that stores machine operation information for preventive maintenance.

When maintaining the machine, our authorized service man may download the stored information.

Consult with your authorized dealer for detailed function of this device.

- **Communication Terminal Operation**

It is not necessary to check or operate the communication terminal however if any abnormality is found, consult your authorized dealer.

Before installing any covering attachment such as a head guard, consult your authorized dealer.

Never spray water on the communication terminal and the wirings.

- **Inquire to your local environmental or recycling center or your authorized dealer, for the proper way to recycle or dispose of oil, fuel, coolant, filters, batteries, DEF/AdBlue® and other waste.**

# MAINTENANCE

## Layout

ZX135US-6, 225USLC-6

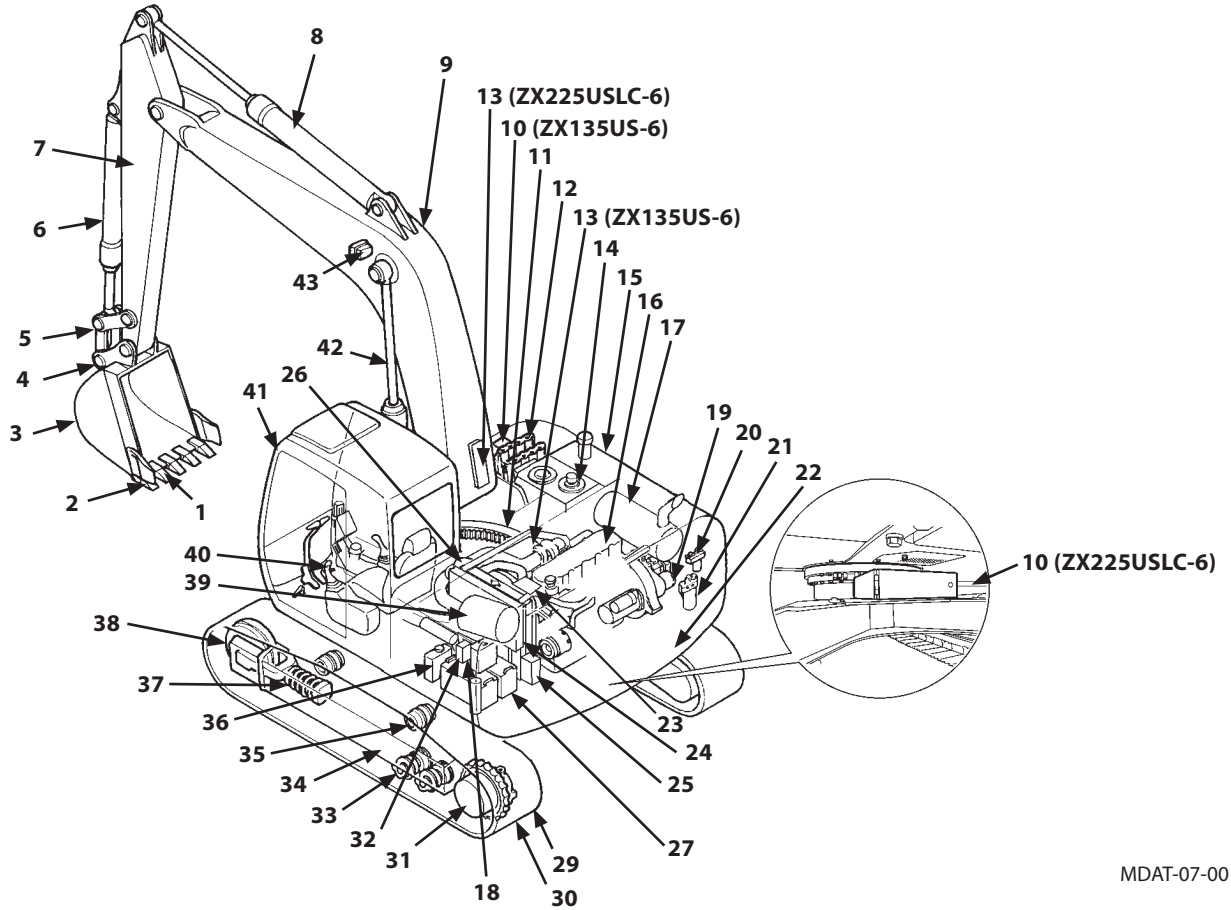

MDAT-07-001

- |                    |                               |  |                    |
|--------------------|-------------------------------|--|--------------------|
| 1- Tooth           | 13- Swing Reduction Gear      | 24- Radiator, Oil Cooler, Inter Cooler | 36- Washer Tank    |
| 2- Side Cutter     | 14- Hydraulic Oil Tank        | 25- DEF/AdBlue® Tank                   | 37- Track Adjuster |
| 3- Bucket          | 15- Fuel Tank                 | 26- Center Joint                       | 38- Front Idler    |
| 4- Link A          | 16- Engine                    | 27- Battery                            | 39- Air Cleaner    |
| 5- Link B          | 17- Aftertreatment Device     | 29- Track Link                         | 40- Control Lever  |
| 6- Bucket Cylinder | 18- DEF/AdBlue® Supply Module | 30- Shoe                               | 41- Cab            |
| 7- Arm             | 19- Pump                      | 31- Travel Device                      | 42- Boom Cylinder  |
| 8- Arm Cylinder    | 20- Pilot Filter              | 32- Battery Disconnect Switch          | 43- Work Light     |
| 9- Boom            | 21- Engine Oil Filter         | 33- Lower Roller                       |                    |
| 10- Tools          | 22- Counterweight             | 34- Track Frame                        |                    |
| 11- Swing Bearing  | 23- Expansion Tank            | 35- Upper Roller                       |                    |
| 12- Control Valve  |                               |  |                    |

# MAINTENANCE

## Layout

### ZX345USLC-6

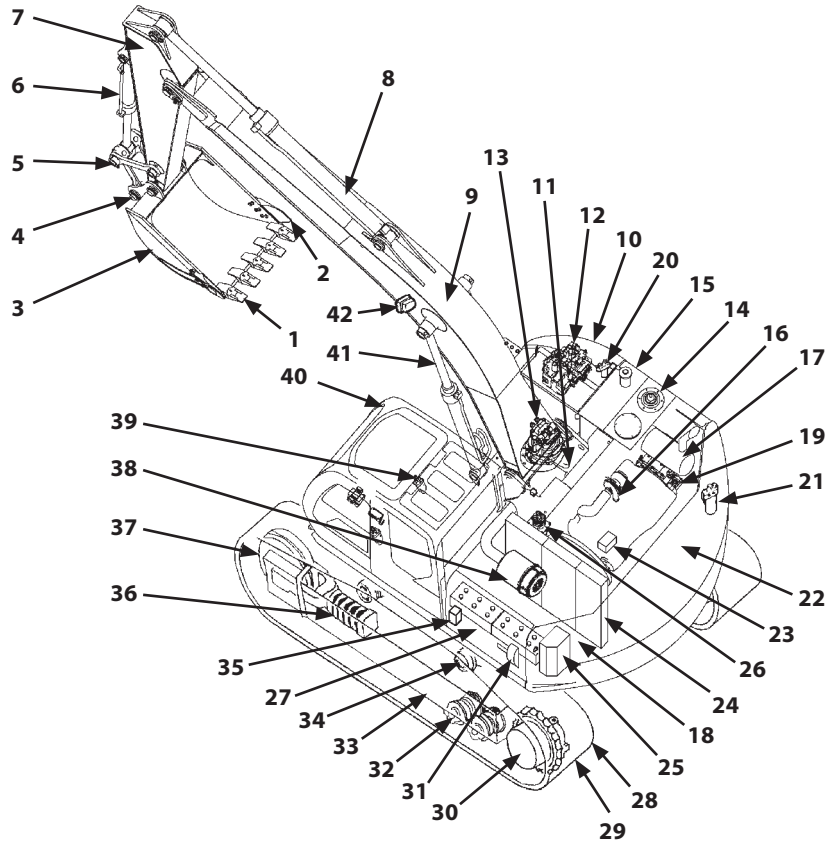

MDD5-01-001

- |                    |                               |                                 |                    |
|--------------------|-------------------------------|---------------------------------|--------------------|
| 1- Tooth           | 13- Swing Reduction Gear      | 24- Radiator, Oil Cooler, Inter | 35- Washer Tank    |
| 2- Side Cutter     | 14- Hydraulic Oil Tank        | Cooler                          | 36- Track Adjuster |
| 3- Bucket          | 15- Fuel Tank                 | 25- DEF/AdBlue® Tank            | 37- Front Idler    |
| 4- Link A          | 16- Engine                    | 26- Center Joint                | 38- Air Cleaner    |
| 5- Link B          | 17- Aftertreatment Device     | 27- Battery                     | 39- Control Lever  |
| 6- Bucket Cylinder | 18- DEF/AdBlue® Supply Module | 28- Track Link                  | 40- Cab            |
| 7- Arm             | 19- Pump                      | 29- Shoe                        | 41- Boom Cylinder  |
| 8- Arm Cylinder    | 20- Pilot Filter              | 30- Travel Device               | 42- Work Light     |
| 9- Boom            | 21- Engine Oil Filter         | 31- Battery Disconnect Switch   |                    |
| 10- Tools          | 22- Counterweight             | 32- Lower Roller                |                    |
| 11- Swing Bearing  | 23- Expansion Tank            | 33- Track Frame                 |                    |
| 12- Control Valve  |                               | 34- Upper Roller                |                    |

## MAINTENANCE

---

### **Check the Hour Meter Regularly**

Refer to the List of Check and Maintenance for information about lubricants, check and adjustment intervals. The maintenance guide table is affixed to the reverse side of the front right cover. Refer to the next page.

This manual recommends grouping the intervals into three categories as follows:

- Daily Check : To be conducted daily before operation
- Monthly check : To be regularly conducted once per month
- Annual check : To be regularly conducted once per year











Check and maintenance intervals shown in this manual are those for the machines to be operated under normal conditions. In case the machine is operated under more severe conditions, shorten the intervals.

## MAINTENANCE

### Maintenance Guide Table

The maintenance guide table is affixed to the reverse side of the front right cover. Lubricate and/or service the parts at the intervals as instructed in the table so that all necessary maintenance can be performed regularly.

- **Symbol Marks**  
The following marks are used in the maintenance guide table.

	Grease (Front Joint Pin, Swing Bearing, Swing Internal Gear)		Hydraulic oil filters (Pilot Filter, Full-Flow Filter, Suction Filter)
	Gear Oil (Pump Transmission, Travel Reduction Gear, Swing Reduction Gear)		Air Cleaner Element
	Engine Oil		Coolant (Long-Life Coolant)
	Engine Oil Filter		Fuel Filter (Fuel Main Filter, Pre-Filter)
	Hydraulic Oil		DEF/AdBlue® Supply Module Main Filter
	Oil Separator Element (Only ZX135US-6)		

# MAINTENANCE

• Maintenance Guide Table  
**ZX135US-6**

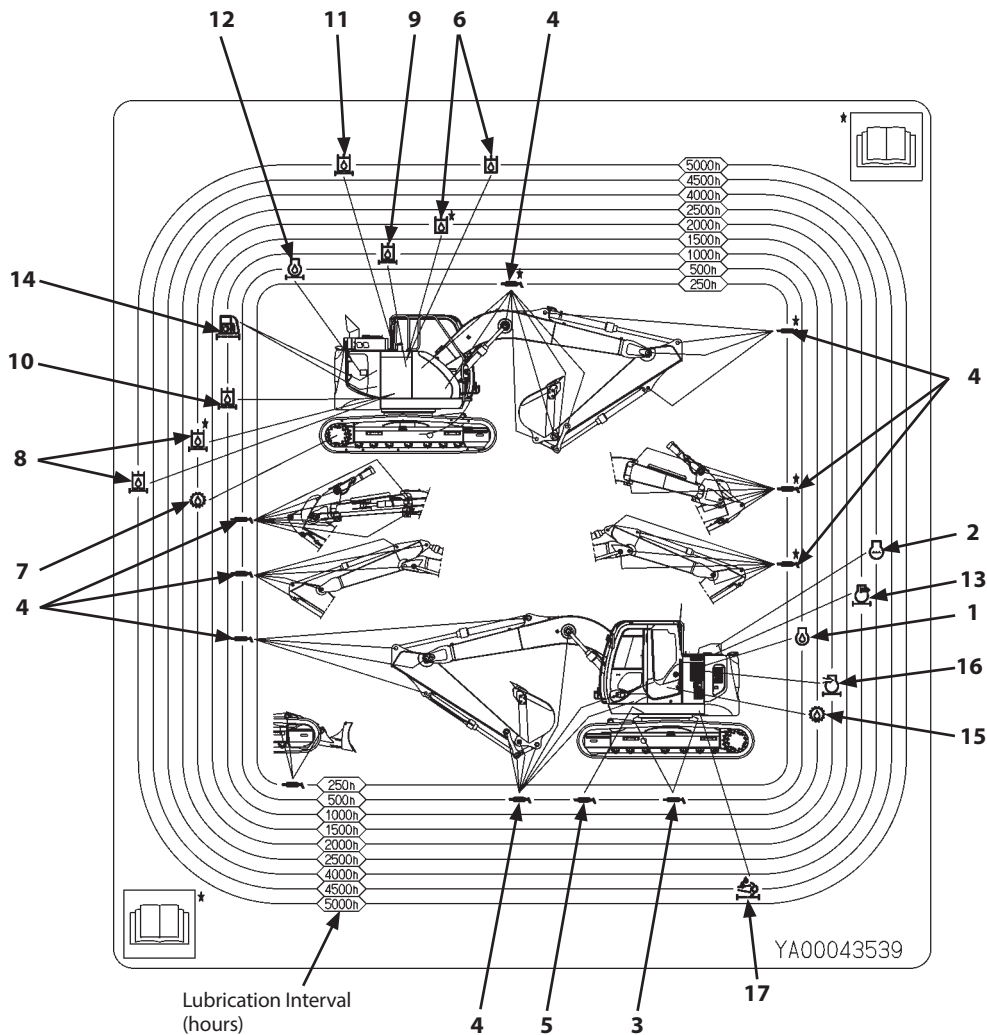

MDAT-07-002

	Item	Page		Item	Page
1	Engine Oil	7-55	10	Hydraulic Oil Filter (Pilot)	7-73
2	Coolant (Long-Life Coolant)	7-98	11	Hydraulic Oil Filter (Air Breather)	7-74
3	Grease	7-32	12	Engine Oil Filter	7-55
4	Grease (Every 500 hours. Only first time at 250 hours)	7-30	13	Oil Separator Element	7-59
5	Grease	7-33	14	Fuel Filter (Main/Pre)	7-85
6	Hydraulic Oil	7-68	15	Gear Oil (Swing Reduction Gear)	7-61
7	Gear Oil (Travel Reduction Gear)	7-63	16	Air Cleaner Element	7-90
8	Hydraulic Oil Filter (Suction)	7-71	17	DEF/AdBlue® Supply Module Main Filter	7-169
9	Hydraulic Oil Filter (Full-Flow)	7-72			

# MAINTENANCE

ZX225USLC-6

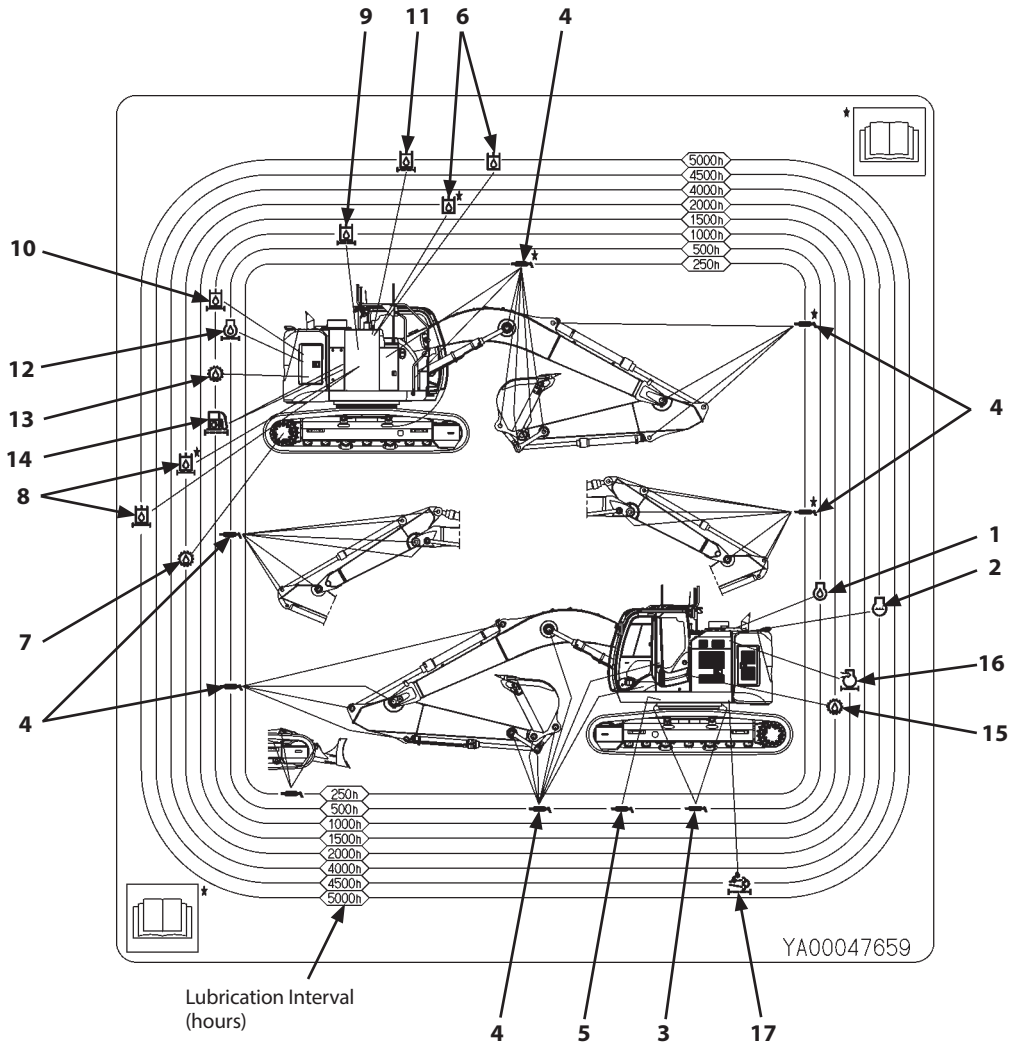

MDAT-07-055

	Item	Page		Item	Page
1	Engine Oil	7-55	10	Hydraulic Oil Filter (Pilot)	7-73
2	Coolant (Long-Life Coolant)	7-98	11	Hydraulic Oil Filter (Air Breather)	7-74
3	Grease	7-32	12	Engine Oil Filter	7-55
4	Grease (Every 500 hours. Only first time at 250 hours)	7-30	13	Gear Oil (Pump Transmission)	7-60
5	Grease	7-33	14	Fuel Filter (Main/Pre)	7-85
6	Hydraulic Oil	7-68	15	Gear Oil (Swing Reduction Gear)	7-61
7	Gear Oil (Travel Reduction Gear)	7-63	16	Air Cleaner Element	7-90
8	Hydraulic Oil Filter (Suction)	7-71	17	DEF/AdBlue® Supply Module Main Filter	7-169
9	Hydraulic Oil Filter (Full-Flow)	7-72			

# MAINTENANCE

ZX345USLC-6

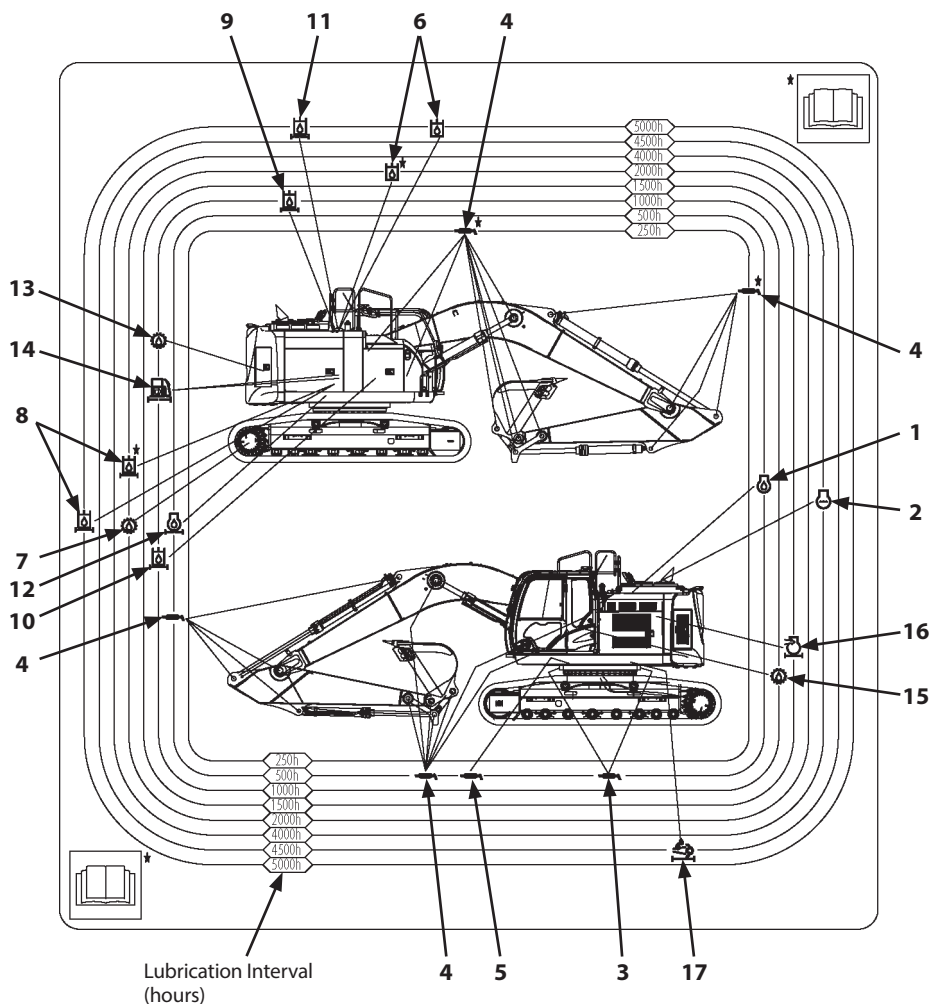

MDD5-07-050

	Item	Page		Item	Page
1	Engine Oil	7-55	10	Hydraulic Oil Filter (Pilot)	7-73
2	Coolant (Long-Life Coolant)	7-98	11	Hydraulic Oil Filter (Air Breather)	7-74
3	Grease	7-32	12	Engine Oil Filter	7-55
4	Grease (Every 500 hours. Only first time at 250 hours)	7-30	13	Gear Oil (Pump Transmission)	7-60
5	Grease	7-33	14	Fuel Filter (Main/Pre)	7-85
6	Hydraulic Oil	7-68	15	Gear Oil (Swing Reduction Gear)	7-61
7	Gear Oil (Travel Reduction Gear)	7-63	16	Air Cleaner Element	7-90
8	Hydraulic Oil Filter (Suction)	7-71	17	DEF/AdBlue® Supply Module Main Filter	7-169
9	Hydraulic Oil Filter (Full-Flow)	7-72			



## MAINTENANCE

### Preparations for Inspection and Maintenance

Except in special cases, park the machine by following the procedure before servicing the machine.

1. Park the machine on a firm, level surface.
2. Lower the bucket to the ground.
3. Turn the auto-idle switch OFF.
4. Turn engine control dial to the slow idle position and run the engine for 5 minutes to cool the engine.
5. Turn the key switch OFF to stop the engine. Remove the key. Be sure to place pilot control shut-off lever (1) to the LOCK position.
6. After putting a tag (2) for "Under Serving" on the easy-to-see cab door or control lever, begin the work.

**⚠ WARNING: Never attempt to maintain the machine when the engine is running in order to prevent the accident. If maintenance work while engine running is unavoidable, strictly comply with the following items.**

- One person should take the operator's seat to be ready to stop the engine any time while communicating with other workers.
- When working around moving parts is unavoidable, pay special attention to ensure that hands, feet, and clothing do not become entangled.
- If parts or tools are dropped or inserted into the fan or the belt, they may fly off or be cut off. Do not drop or insert parts and tools into the moving parts.
- Move pilot control shut-off lever (1) to LOCK position so that the front attachment will not move.
- Never touch the control levers and pedals. If operating the control levers or pedals is unavoidable, signal co-workers to evacuate to safer place.



M104-07-021

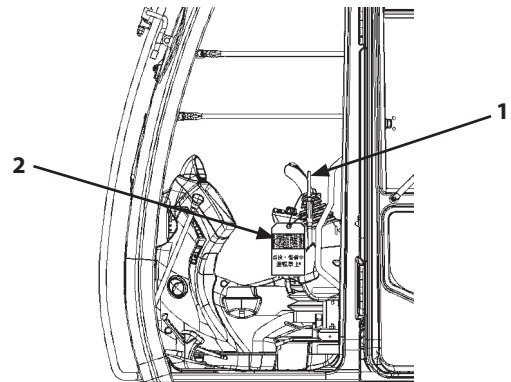

MDCN-07-001

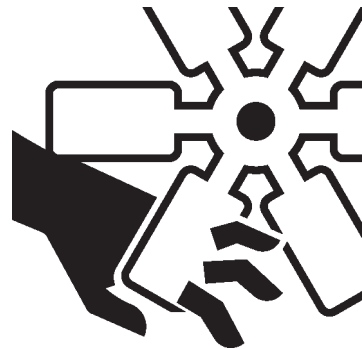

SA-2294

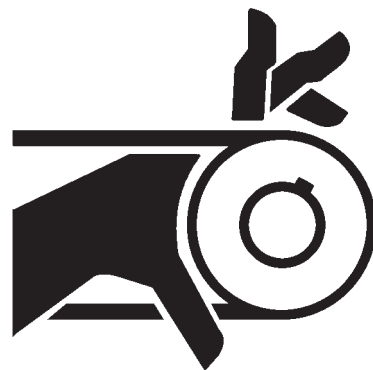

SA-026

# MAINTENANCE

## Hood and Access Covers

ZX135US-6

### WARNING:

- Do not keep the hood and access covers open when the machine is parked on a slope, or while the wind is blowing hard. The hood or access covers may close accidentally, possibly resulting in personal injury.
- When opening or closing the hood and access covers, take extra care not to catch fingers between the base machine and the hood or access covers.
- Holding the handle on the access cover, raise the cover until the cover is secured with catch (1).
- After opening the right and/or left access cover, be sure to insert rod (2) into cover lock hole (3) to hold the cover.

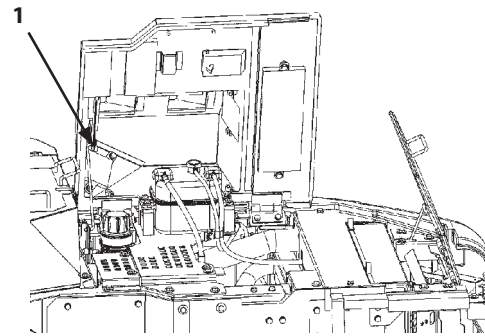

Engine Cover

MDAT-07-003

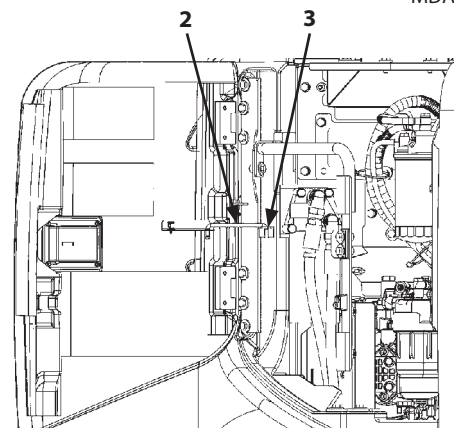

Rear Right Cover

MDAT-07-004

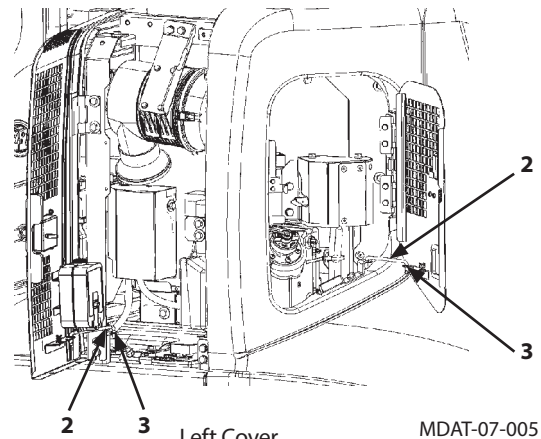

Left Cover

MDAT-07-005

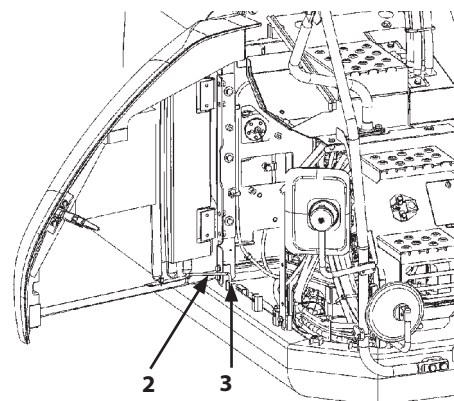

Front Right Cover

MDAT-07-006

## MAINTENANCE

### ZX225USLC-6

#### WARNING:

- Do not keep the hood and access covers open when the machine is parked on a slope, or while the wind is blowing hard. The hood or access covers may close accidentally, possibly resulting in personal injury.
- When opening or closing the hood and access covers, take extra care not to catch fingers between the base machine and the hood or access covers.
- Holding the handle on the access cover, raise the cover until the cover is secured with catch (1).
- After opening the right and/or left access cover, be sure to insert rod (2) into cover lock hole (3) to hold the cover.

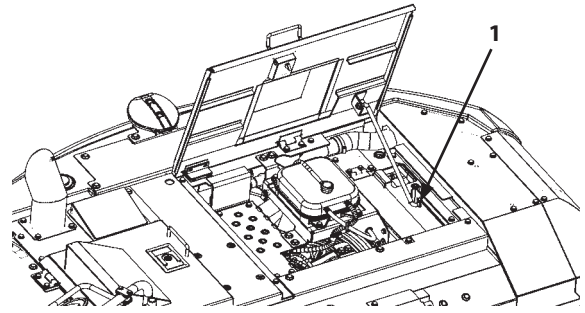

Engine Cover

MDAT-07-007

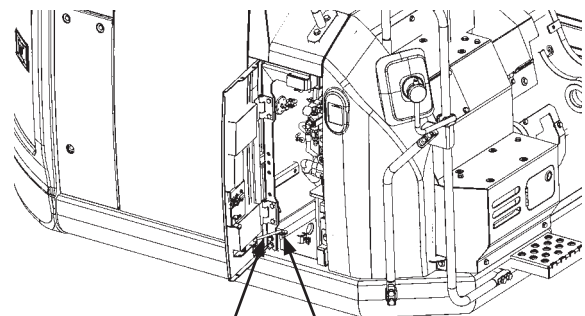

2 3  
Front Right Cover

MDAT-07-008

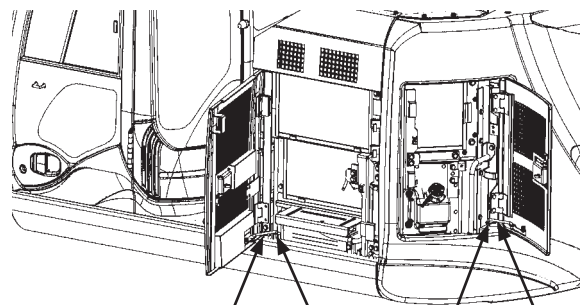

2 3 3 2  
Left Cover

MDAT-07-009

## MAINTENANCE

### ZX345USLC-6

#### WARNING:

- Do not keep the hood and access covers open when the machine is parked on a slope, or while the wind is blowing hard. The hood or access covers may close accidentally, possibly resulting in personal injury.
- When opening or closing the hood and access covers, take extra care not to catch fingers between the base machine and the hood or access covers.
- Holding the handle on the access cover, raise the cover until the cover is secured with catch (1).
- When opening the engine cover, open the left engine cover (5). Then, pull to open the right engine cover (4) as illustrated.
- After opening the right and/or left access cover, be sure to insert rod (2) into cover lock hole (3) to hold the cover.

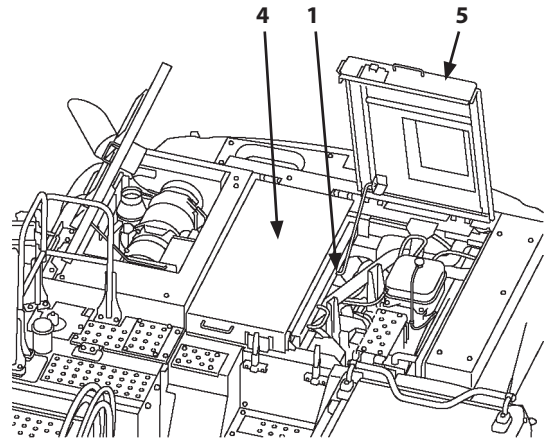

Engine Cover

MDD5-07-001

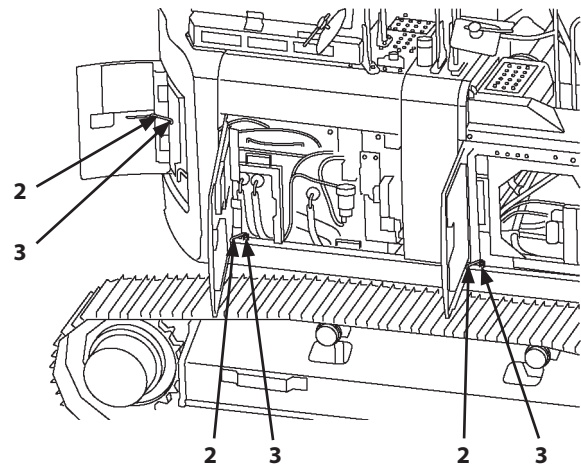

Right Cover

MDD5-07-002

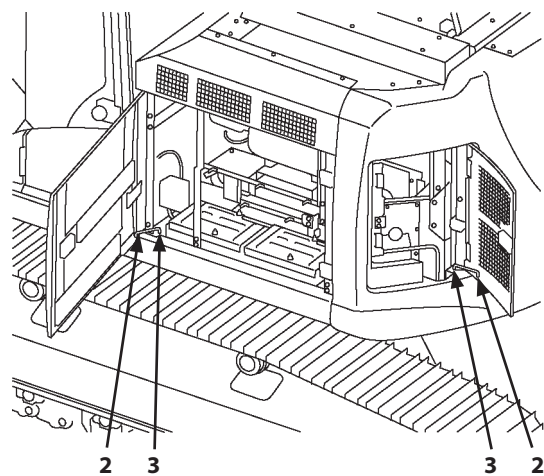

Left Cover

MDD5-07-003

## MAINTENANCE

### Maintenance Guide

#### A. Greasing

	Parts		Quantity	Interval (hours)						Page	
				8	50	100	250	500	1000		2000
1.	Front Joint Pins	Bucket and Link Pins	9	★			★★				7-30
		Others	11	★			★★				7-30
2.	Swing Bearing		2								7-32
3.	Swing Internal Gear		1					★★★			7-33

★ : Add grease daily during first 50 hours of operation.

In case excavations are performed in water, grease the pin after operation is complete.

Shorten greasing intervals when the machine is operated under severe conditions or when the machine is continuously operated for a long period of time.

★★ : 250 hours for only first time.

★★★ : Check and add grease if necessary.

#### IMPORTANT:

- Grease bucket and link pivots every day until break-in operation (50 hours) is complete.
- When a bucket which does not have clearance adjustment mechanism such as slope-finishing bucket or V-type bucket, or a genuine Hitachi hoe bucket before EX-5 model, or an attachment other than genuine Hitachi bucket is used, grease two pins every 250 hours.

#### B. Engine

	Parts		Quantity	Interval (hours)						Page	
				8	50	100	250	500	1000		2500
1.	Engine Oil	Check Oil Level	1								7-53
2.	Engine Oil	Change	ZX135US-6	17 L							7-55
			ZX225USLC-6	23 L							
			ZX345USLC-6	48 L							
3.	Engine Oil Filter	Replace	1								7-55
4.	Check and Clean Around the Engine		–	As required							7-59
5.	Replace Oil Separator Element (ZX135US-6)		1								7-59

## MAINTENANCE

### C. Transmission

Parts		Quantity	Interval (hours)							Page		
			8	50	100	250	500	1000	2000			
1.	Pump Transmission	Check Oil Level	1								7-60	
		Change	ZX225USLC-6	1.6 L								7-60
			ZX345USLC-6	1.7 L								
		Air Breather Cleaning	1									7-60
2.	Swing Reduction Gear	Check Oil Level	1								7-61	
		Change	ZX135US-6	3.2 L								7-61
			ZX225USLC-6	6.9 L								
			ZX345USLC-6	11.7 L								
3.	Travel Reduction Gear	Check Oil Level	2								7-62	
		Change	ZX135US-6	4.2 L×2								7-63
			ZX225USLC-6	6.8 L×2								
			ZX345USLC-6	11 L×2								

### D. Hydraulic System

Parts		Quantity	Interval (hours)									Page			
			8	50	100	250	500	1000	1500	2000	2500		5000		
1.	Check Hydraulic Oil Level	1												7-67	
2.	Change Hydraulic Oil **Hydraulic oil capacity (amount at oil change)	ZX135US-6	155 L (60 L)											7-68	
		ZX225USLC-6	240 L (130 L)									★			
		ZX345USLC-6	251 L (160 L)												
3.	Suction Filter Cleaning	1	Each time when hydraulic oil is changed									7-71			
4.	Replace full-flow filter	Std. Model	1											7-72	
5.	Replace Pilot Oil Filter	1												7-73	
6.	Replace Air Breather Element	1												7-74	
7.	Check Hoses and Lines	for leaks, loose												7-75	
		for cracks, bend, etc.	–												

★ : Changing interval differs according to the brand of hydraulic oil used, kind of filter element or average attachment operating availability.

Refer to the "changing intervals of hydraulic oil and full flow filter element". See recommended oil chart.

\*\* : Hydraulic oil capacity indicates the entire amount of oil, including oil in the hydraulic oil tank, devices and lines. Amount at oil change means the amount of oil that is changed during inspection and maintenance.

## MAINTENANCE

### E. Fuel System

Parts		Quantity	Interval (hours)						Page	
			8	50	100	250	500	1000		2000
1.	Drain Fuel Tank Sump	1								7-81
2.	Drain Fuel Pre-Filter	1								7-82
3.	Replace Fuel Main Filter Element	1	(or when indicator lit)							7-85
4.	Replace Fuel Pre-Filter Element	1	(or when indicator lit)							7-87
5.	Check Fuel Hoses	for leaks, cracks								7-89
		for cracks, bend, etc.								7-89

### F. Air Cleaner

Parts		Quantity	Interval (hours)						Page	
			8	50	100	250	500	1000		2000
1.	Air Cleaner Outer Element	Clean	(or when indicator lit)							7-90
		Replace	After cleaning 6 times or 1 year						7-90	
2.	Air Cleaner Inner Element	Replace	When outer element is replaced						7-92	

## MAINTENANCE

### G. Cooling System

Parts		Quantity	Interval (hours)							Page	
			8	50	100	250	500	1000	2000		
1.	Check Coolant Level	1								7-94	
2.	Check and Adjust Fan Belt Tension	1		★★						7-96	
3.	Change Coolant	ZX135US-6	21 L	Twice a year*							7-98
		ZX225USLC-6	28 L								
		ZX345USLC-6	41 L								
4.	Clean Radiator, Oil Cooler and Inter Cooler Core	Outside	1					★		7-100	
		Inside	1	Once a year							7-100
5.	Clean Oil Cooler, Radiator and Inter Cooler Front Screen	1					★			7-102	
6.	Clean Air Conditioner Condenser	1					★			7-102	
7.	Clean Fuel Oil Cooler	1					★			7-102	
8.	Drain Intercooler	1	★★★							7-103	

★: Shorten the maintenance interval when the machine is operated in dusty areas.

★★: Maintenance required only during first time check.

★★★: If there is a risk of freezing, remove condensate after operating the machine. (only ZX135US-6)

\*: When genuine Hitachi Long-Life Coolant is used, change every two years or 4000 operating hours, whichever comes first.

#### IMPORTANT:

- **Use soft water as a coolant. Do not use strong acid or alkaline water. Use the coolant with genuine Hitachi Long-Life Coolant (LLC) mixed by 30 to 50 %. If a coolant mixed with less than 30 % of Hitachi Long-Life Coolant is used, service life of the cooling parts may be shortened due to damage by freezing or corrosion of coolant system parts.**
- **If mineral-rich water is used for coolant, water stain or scale may build up inside the engine or radiator, causing overheating due to deterioration of coolant performance.**
- **Condensate may accumulate inside the intercooler under some conditions of use. (only ZX135US-6)**
- **Freezing of condensate may cause damage to the intercooler. (only ZX135US-6)**

### H. Electrical System

Parts		Quantity	Interval (hours)							Page	
			8	50	100	250	500	1000	2000		
1.	Battery	Check Electrolyte Level	2	Every month							7-107
		Check electrolyte specific gravity	2	Every month							7-109
2.	Replacing Fuses	Replace	–	As required							7-110



## MAINTENANCE

### I. Miscellaneous

Parts		Quantity	Interval (hours)							Page	
			8	50	100	250	500	1000	2000		4500
1.	Check and Replace Bucket Teeth	–									7-113
2.	Change Bucket	–	As required							7-115	
3.	Convert Bucket Connection Into Face Shovel	–	As required							7-116	
4.	Adjust Bucket Linkage	1	As required							7-117	
5.	Remove Travel Levers	2	As required							7-118	
6.	Check and Replace Seat Belt	1		Every 3 years						7-118	
7.	Check Windshield Washer Fluid Level	1	As required							7-119	
8.	Check Track Sag	2									7-120
9.	Clean and Replace Air Conditioner Filter	Circulating Air Filter	Clean	1							7-125
			Replace	1	After cleaning 6 times or so						
	Fresh Air Filter	Clean	1								7-125
			Replace	1	After cleaning 6 times or so						
10.	Check Air Conditioner	–									7-128
11.	Clean Cab Floor	–	As required							7-130	
12.	Retighten Cylinder Head Bolt	–	*As required							7-131	
13.	Inspect and Adjust Valve Clearance	–						*			7-131
14.	Measure Engine Compression Pressure	–						*			7-131
15.	Check Starter and Alternator	–						*			7-131
16.	Check and Replace EGR Device	–	*As required							7-131	
17.	EGR Cooler Cleaning	–								*	7-131
18.	Check Turbo Charger	–								*	7-131
19.	Check and Clean Injector	–								*	7-132
20.	Check Gas Damper	–	*As required							7-132	
21.	Tightening and Retightening Torque of Nuts and Bolts	–		★★							7-132

★★: Maintenance required only during first time check.

 NOTE: \* Contact your authorized dealer for maintenance. Instruction plate for the recommended grease and lubricants is affixed to the reverse side of the front right cover.

## MAINTENANCE

### J. Aftertreatment Device

	Parts	Quantity	Interval (hours)							Page
			8	50	100	250	500	1000	2000	
1.	Check and Clean Aftertreatment Device	–	As required							7-161

### K. Urea SCR System

	Parts	Quantity	Interval (hours)							Page	
			8	50	100	250	500	1000	2000		4500
1.	Check DEF/AdBlue®	1									7-164
2.	Replace DEF/AdBlue® Supply Module Main Filter	1									7-169
3.	Replace DEF/AdBlue® Tank Water Supply Inlet Filter	1	*If DEF/AdBlue® overflows when supplying water							*	7-171
4.	Replace DEF/AdBlue® Back Flow Line Filter	1								*	7-172

 NOTE: \* Contact your authorized dealer for maintenance.

### L. Aerial Angle

	Parts	Quantity	Interval (hours)							Page	
			8	50	100	250	500	1000	2000		4500
1.	Daily Checks of Aerial Angle Camera Images	–									7-173
2.	Checking Aerial Angle Camera Images	–	Whenever work that affects the camera installation position is done								7-174

## MAINTENANCE

### Periodic Replacement of Parts

To ensure safe operation, be sure to conduct periodic inspection of the machine. In addition, the parts listed below, if defective, may pose serious safety/fire hazards.

These parts may cause serious safety/fire hazards due to deterioration, wear, or fatigue being attributed to material aging or repeated operation. It is very difficult to gauge the extent of deterioration, fatigue, or weakening of the parts listed below simply by visual inspection alone. For this reason, replace these parts at the intervals shown in the table below. Consult your authorized dealer for correct replacement.

Periodic Replacement Parts		Replacement Intervals	
Engine	Fuel hose (Fuel tank, Filter to Engine)	Every 2 years	
	Fuel hose (Engine, Fuel cooler to Fuel tank)	Every 2 years	
	DEF/AdBlue® hoses	Every 2 years	
	Oil filter hose (Engine to oil filter)	Every 2 years	
	Heater hose (Heater to engine)	Every 2 years	
Hydraulic System	Base Machine	Pump suction hose	Every 2 years or 4000 hours whichever comes first
		Pump delivery hose	Every 2 years or 4000 hours whichever comes first
		Swing hose	Every 2 years or 4000 hours whichever comes first
		Travel high pressure hose	Every 2 years or 4000 hours whichever comes first
		Tail Hose	Every 2 years or 4000 hours whichever comes first
		Attachment Line Hose	Every 2 years or 4000 hours whichever comes first
		Hydraulic Fan Suction Hose	Every 2 years or 4000 hours whichever comes first
	Hydraulic Fan Delivery Hose	Every 2 years or 4000 hours whichever comes first	
	Working Device	Boom cylinder line hose	Every 2 years or 4000 hours whichever comes first
		Arm cylinder line hose	Every 2 years or 4000 hours whichever comes first
Bucket cylinder line hose		Every 2 years or 4000 hours whichever comes first	
Seat Belt		Every 3 years	

 **NOTE:** Be sure to replace seals, such as O-rings and gaskets, when replacing hoses.

## MAINTENANCE

---

### Kind of Oils

#### Brand Names of Recommended Grease

Kind of Grease	Lithium Grease
Application	Front Attachment Joint Pins, Swing Bearing, Swing Internal Gear
Air Temp.	-20 to 40 °C (-4 to 104 °F)
Recommended Products	Hitachi Genuine Grease NLGI EP-2
Alternative Products	Specification NLGI 2 EP

#### IMPORTANT:

- **Hitachi Genuine Greases are specially designed and tested to provide optimum performance for the machine, hence we recommend to use Hitachi Genuine Greases.**
- **If you do not use Hitachi Genuine Greases, use grease conforming to EP-2. Otherwise, the machine may suffer damage.**
- **Do not use greases which do not meet the above specification or requirements. Use of unsuitable grease may lead to damage which is excluded from Hitachi Warranty Policy.**
- **For details, contact your nearest authorized dealer.**

#### Recommended Engine Oil

Kind of Oil	Engine Oil
Application	Engine Crank Case
Air Temp.	-20 to 40 °C (-4 to 104 °F)
Recommended Products	Hitachi Genuine Engine Oil 10W-40 DH-2
Alternative Products	Viscosity 10W-40
	Specification JASO DH-2

#### IMPORTANT:

- **Hitachi Genuine Engine Oils are specially designed and tested to provide optimum performance for machine, hence we recommend to use Hitachi Genuine Engine Oils.**
- **If you do not use Hitachi Genuine Engine Oil, use engine oil conforming to JASO DH-2. Otherwise, engine and aftertreatment device may suffer damage or performance of engine and aftertreatment device may deteriorate.**
- **Do not use oils which do not meet the above specification or requirements. Use of unsuitable oil may lead to engine damage which is excluded from Hitachi Warranty Policy.**
- **For details, contact your nearest authorized dealer.**

## MAINTENANCE

### Brand Names of Recommended Oil

Application		Swing and Travel Reduction Gear	Pump Transmission
Kind of Oil		Gear Oil	Engine Oil
Air Temp.		-20 to 40 °C (-4 to 104 °F)	-20 to 40 °C (-4 to 104 °F)
Recommended Products		Hitachi Gear Oil GL-4 90	Hitachi Genuine Engine Oil DH-2 10W-40 Hitachi Genuine Engine Oil DH-1 15W-40
Alternative Products	Specification	API GL-4	API CD, JASO DH-1, JASO DH-2

#### IMPORTANT:

- **Hitachi Genuine Gear Oil and Hitachi Genuine Engine Oil are specially designed and tested to provide optimum performance for the machine, hence we recommend to use Hitachi Genuine Gear Oil and Hitachi Genuine Engine Oil .**
- **If you do not use Hitachi Genuine Gear Oil or Hitachi Genuine Engine Oil , use gear oil or engine oil conforming to specifications described above. Otherwise, the machine may suffer damage.**
- **Do not use oils which do not meet the above specification or requirements. Use of unsuitable oil may lead to engine damage which is excluded from Hitachi Warranty Policy.**
- **For details, contact your nearest authorized dealer.**

### Brand Names of Recommended Hydraulic Oil

Kind of Lubricant		Hydraulic Oil		
Where to be applied		Hydraulic System		
Environmental Temp.		-20 to 40 °C (-4 to 104 °F)		
Recommended Products		Hitachi Genuine Hydraulic Oil 5000	Hitachi Genuine Hydraulic Multi	
Alternative Products	Specification			Product Conforming to JCMAS HK VG46W
Change Interval		5000 hour	1500 hour	

 **NOTE:** A different interval of oil change may be required for Alternative Products.

For details, contact your nearest authorized dealer.

#### IMPORTANT:

- **Hitachi Genuine Hydraulic Oils are specially designed and tested to provide optimum performance for the machine, hence we recommend to use Hitachi Genuine Hydraulic Oils.**
- **If you do not use Hitachi Genuine Hydraulic Oil , use Hydraulic oil conforming to JCMAS HK VG46W. Otherwise, the machine may suffer damage. For the information of JCMAS HK VG46W, refer to JALOS website.**
- **Do not use oils which do not meet the above specification or requirements. Use of unsuitable oil may lead to damage which is excluded from Hitachi Warranty Policy.**
- **For details, contact your nearest authorized dealer.**

## MAINTENANCE

### Recommended Oil Viscosity

Where to be Applied	Kind of Oil	Air Temperature (degrees Celsius)								
		-30	-20	-10	0	10	20	30	40	
Engine Oil Pan	Engine Oil									Hitachi Genuine Engine Oil DH-2 10W-40
Pump Transmission	Engine Oil									Hitachi Genuine Engine Oil DH-2 10W-40
										Hitachi Genuine Engine Oil DH-1 15W-40
Swing Reduction Gear Travel Reduction Gear	Gear Oil									Hitachi Gear Oil GL-4 90
Hydraulic System (Hydraulic Oil Tank)	Hydraulic Oil									Hitachi Genuine Hydraulic Oil 5000 Hitachi Genuine Hydraulic Oil Multi
Fuel Tank	Diesel Fuel									EN590 Class A
										EN590 Class B
										EN590 Class C
										EN590 Class D
										EN590 Class E
										EN590 Class F
Grease fitting	Lithium Grease									Hitachi Genuine Grease NLGI EP-2
Radiator	Coolant									Hitachi Genuine Long Life Coolant

## MAINTENANCE

### List of Consumable Parts

#### ZX135US-6

##### Filter Elements

	Part No.	Quantity
High Performance Full-Flow Filter	4450002	1
Hydraulic Air Breather Element	4437838	1
Pilot Oil Filter (with O-ring)	4630525	1
Engine Oil Filter	4658521	1
Fuel Main Filter Element	YA00033486	1
Fuel Pre-Filter Element	YA00005785	1
Fuel Filter Element (Automatic Refueling Device)	YA00029016	1
Air Cleaner Element (outer)	4486002	1
Air Cleaner Element (inner)	4486014	1
Air Conditioner Circulating Air Filter	YA00011003	1
Air Conditioner Fresh Air Filter	4350249	1
DEF/AdBlue® Supply Module Main Filter	YA00047054	1
Oil Separator Element	YA00045915	1
DEF/AdBlue® Tank Water Supply Inlet Filter	YA60085046	1

##### Drive Belts

	Part No.	Quantity
Engine Fan Belt	4668374	1
Air Conditioner Compressor Belt	4686087	1

##### Others

	Part No.	Quantity
Wiper Blade	4650572	1

## MAINTENANCE

### Bucket Parts

		Part No.	Quantity
Tooth	Tooth	963228	5
	Lock Pin	963229	5
	Lock Rubber	963227	5
	Side Cutter (right side)	2015428	1
	Side Cutter (left side)	2015429	1
Side Cutter	Bolt	J932060	8
	Nut	J951020	8
	Spring Washer	A590920	8
O-ring	4276696	4	

 **NOTE:** Quantity row on the above table represents number of parts used for one bucket. The parts quantity of O-ring includes connection part of arm and link

### Optional Parts

		Part No.	Quantity
Clamshell Bucket	Tooth	452632	6
	Bolt	447167	18
	Nut	452064	18
	Spring Washer	A590922	18
One Point Ripper	Tooth	971377	1
	Pin	971378	1
	Bushing Rubber	971379	1
Ripper Bucket	Tooth	971377	1
	Pin	971378	1
	Bushing Rubber	971379	1
	Tooth	4501627	2
	Lock Pin	4319920	2



## MAINTENANCE

### ZX225USLC-6

#### Filter Elements

	Part No.	Quantity
High Performance Full-Flow Filter	YA00033064	1
Hydraulic Air Breather Element	4437838	1
Pilot Oil Filter (with O-ring)	4630525	1
Engine Oil Filter	4658521	1
Fuel Main Filter Element	YA00033486	1
Fuel Pre-Filter Element	YA00005785	1
Fuel Filter Element (Automatic Refueling Device)	YA00029016	1
Air Cleaner Element (outer)	4286128	1
Air Cleaner Element (inner)	4286130	1
Air Conditioner Circulating Air Filter	YA00011003	1
Air Conditioner Fresh Air Filter	4350249	1
DEF/AdBlue® Supply Module Main Filter	YA00047054	1
DEF/AdBlue® Tank Water Supply Inlet Filter	YA60085046	1

#### Drive Belts

	Part No.	Quantity
Engine Fan Belt	4642643	1
Air Conditioner Compressor Belt	YA00007116	1

#### Others

	Part No.	Quantity
Wiper Blade	4650572	1

#### Bucket Parts

		Part No.	Quantity
Tooth	Tooth	4427919	5
	Lock Pin	4501627	5
	Lock Rubber	4501625	5
	Side Cutter (right side)	2014503	1
	Side Cutter (left side)	2014504	1
Side Cutter	Bolt	J932270	12
	Nut	J951022	12
	Spring Washer	A590922	12
O-ring		4089028	4

 **NOTE:** Quantity row on the above table represents number of parts used for one bucket. The parts quantity of O-ring includes connection part of arm and link.

## MAINTENANCE

### Optional Parts

		Part No.	Quantity
Clamshell Bucket	Tooth	452632	8
	Bolt	J932280	24
	Nut	J951022	24
	Spring Washer	A590922	24
One Point Ripper	Tooth	971377	1
	Pin	971378	1
	Bushing Rubber	971379	1
Ripper Bucket	Tooth	971377	1
	Pin	971378	1
	Bushing Rubber	971379	1
	Tooth	4427919	2
	Lock Pin	4501627	2
	Lock Rubber	4319920	2
Ditch Cleaning Bucket (0.30, 0.35, 0.40 m <sup>3</sup> )	Tooth	973347	*
	Lock Pin	963229	*
	Lock Rubber	963227	*
Reinforced Hoe Bucket HD Type	Tooth	4427919	5
	Lock Pin	4501627	5
	Lock Rubber	4501625	5
Reinforced Hoe Bucket HD Type (Transverse- Type-Pin)	Tooth	4364121	5
	Pin	4364125	5
Hoe Bucket with Super V type Bucket Teeth	Tooth	4383048	5
Reinforced Hoe Bucket	Pin	4383069	5

 NOTE: The parts quantity of items with\* mark.

- Four parts are required per each bucket 0.30, 0.35 and 0.40 m<sup>3</sup>.
- Seven parts are required per one ditch cleaning bucket with teeth.

## MAINTENANCE

### ZX345USLC-6

#### Filter Elements

	Part No.	Quantity
Full-Flow Filter (with O-ring)	YA00033065	1
High Performance Full-Flow Filter	YA00033064	1
Hydraulic Air Breather Element	4437838	1
Pilot Oil Filter (with O-ring)	4630525	1
Engine Oil Filter	4658521	1
Fuel Main Filter Element	YA00033486	1
Fuel Pre-Filter Element	YA00005785	1
Air Cleaner Element (outer)	4459549	1
Air Cleaner Element (inner)	4459548	1
Air Conditioner Circulating Air Filter	YA00001490	1
Air Conditioner Fresh Air Filter	YA00032683	1
DEF/AdBlue® Supply Module Main Filter	YA00047054	1
DEF/AdBlue® Tank Water Supply Inlet Filter	YA60085046	1

#### Drive Belts

	Part No.	Quantity
Engine Fan Belt	4603925	1
Air Conditioner Compressor Belt	4612331	1

#### Others

	Part No.	Quantity
Wiper Blade	4650572	1

#### Bucket Parts

		Part No.	Quantity
Tooth	Tooth	4512365	5
	Lock Pin	4512366	5
	Lock Rubber	4501625	5
Side Cutter	Side Cutter (right side)	2021232	1
	Side Cutter (left side)	2021233	1
	Bolt	J932275	12
	Nut	J951022	12
	Spring Washer	A590922	12
O-ring		4089028	4

 **NOTE:** Quantity row on the above table represents number of parts used for one bucket. The parts quantity of O-ring includes connection part of arm and link

## MAINTENANCE

### Optional Parts

		Part No.	Quantity
One Point Ripper	Tooth	4507888	1
	Pin	4507890	1
	Bushing Rubber	4507891	1
Ripper Bucket	Tooth	4507888	1
	Pin	4507890	1
	Bushing Rubber	4507891	1
	Tooth	4383048	2
	Lock Pin	4383069	2
Rock Bucket	Tooth	4400253	5
	Lock Pin	4383465	5
	Shroud	4435856	1
	Shroud	4435857	1
	Bolt	J932780	6
	Nut	J951027	6
	Washer	4085857	6
Reinforced Hoe Bucket HD Type	Tooth	4512365	5
	Lock Pin	4512366	5
	Lock Rubber	4501625	5

# MAINTENANCE

## A. Greasing

- 1** Front Joint Pins  
--- every 500 hours (first time after 250 hours)

Lubricate all fittings shown in the figure.

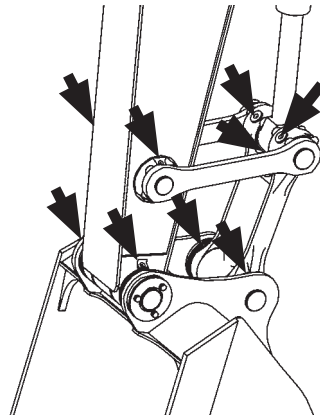

M178-07-007

- Boom Cylinder Bottom Side

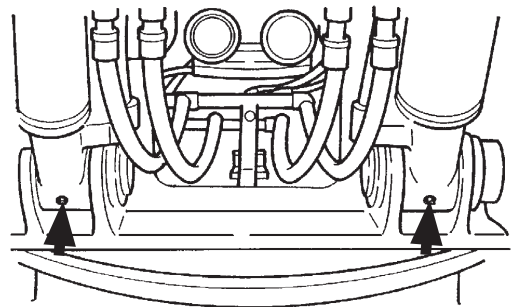

M157-07-156

- Boom Foot

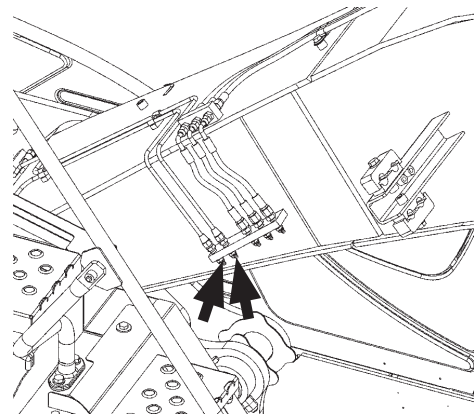

ZX135US-6

MDAT-07-010

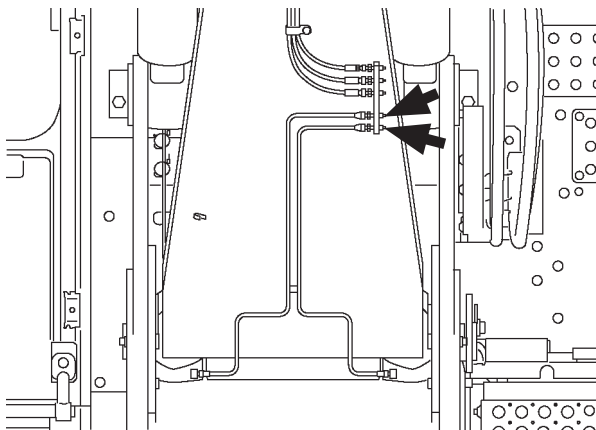

ZX345USLC-6

MDD5-07-004

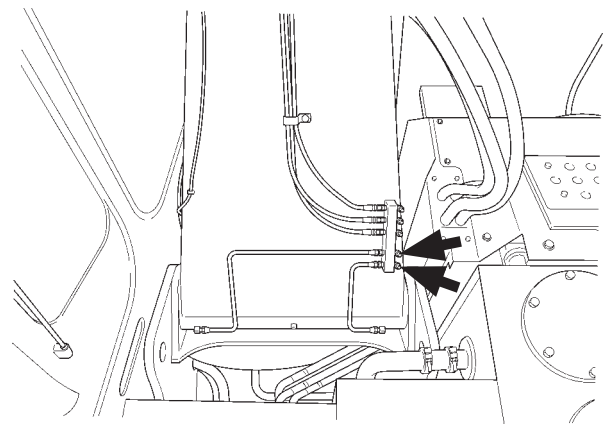

ZX225USLC-6

M178-07-082

# MAINTENANCE

- Boom and Arm Joint Pin, Arm Cylinder Rod Pin and Bucket Cylinder Bottom Pin

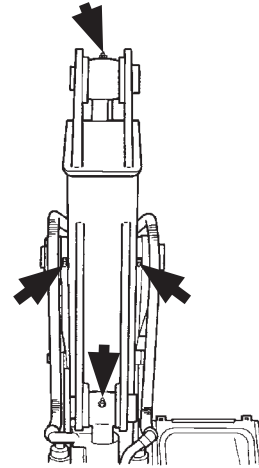

M157-07-157

- Boom Cylinder Rod Pins and Arm Cylinder Bottom Pin

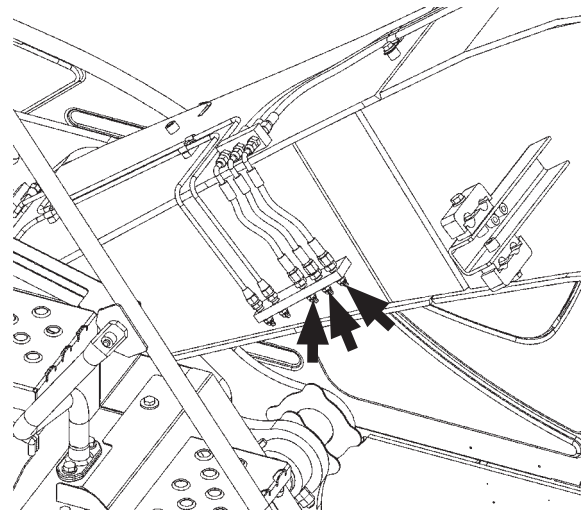

ZX135US-6

MDAT-07-010

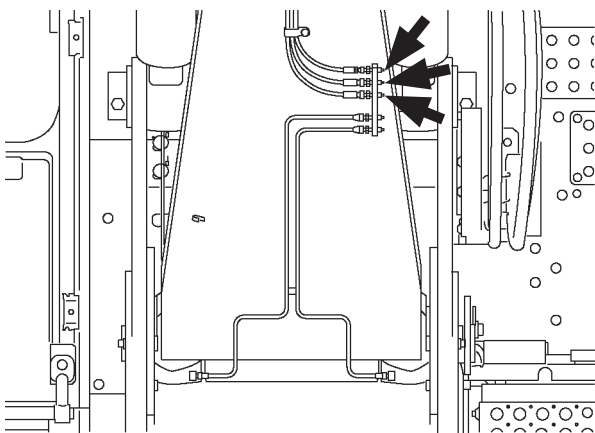

ZX345USLC-6

MDD5-07-004

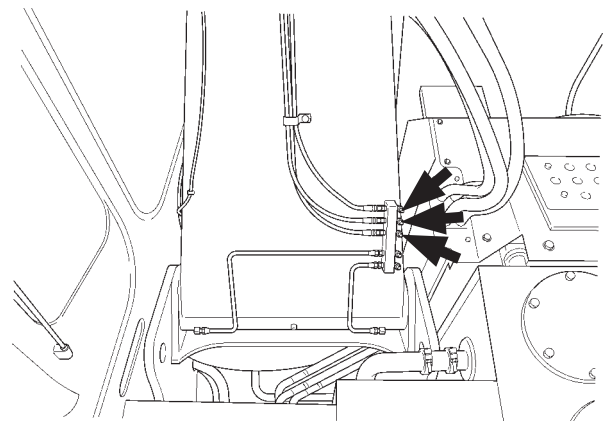

ZX225USLC-6

M178-07-082

## MAINTENANCE

### 2 Swing Bearing --- every 500 hours

**CAUTION:** Lubricating both the swing bearing and gear, and rotating the upperstructure must be done by one person. Before you lubricate the swing bearing, clear the area of all persons.

Each time you leave the cab

- Lower the bucket to the ground.
- Stop the engine.
- Pull the pilot control shut-off lever to the LOCK position.
- Use handrails.

1. Park the machine on a level surface.
2. Lower the bucket to the ground.
3. Turn the auto-idle switch off.

**IMPORTANT:** The turbocharger may be damaged if the engine is not properly shut down.

4. Run the engine at slow idle speed without load for five minutes.
5. Turn the key switch OFF. Remove the key from the key switch.
6. Pull the pilot control shut-off lever to the LOCK position.
7. With the upperstructure stationary, apply grease via the 2 grease fittings.
8. Start the engine. Raise the bucket several inches off the ground and rotate the upperstructure 45 ° (1/8 turn).
9. Lower the bucket to the ground.
10. Repeat the procedure 3 times, beginning with step 3.
11. Apply grease to the swing bearing until grease can be seen escaping from the swing bearing seals.

Model	Capacity
ZX135US-6	0.25 L
ZX225USLC-6	0.30 L
ZX345USLC-6	0.40 L

12. Take care not to supply excessive grease.

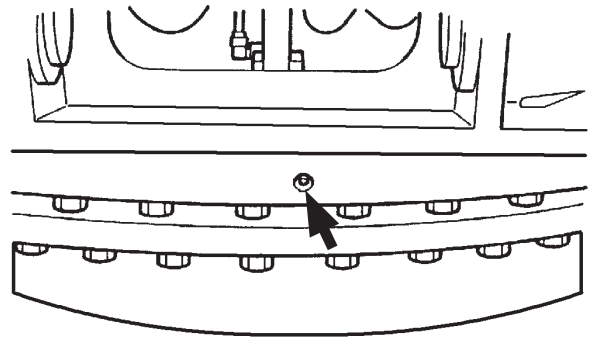

M157-07-159

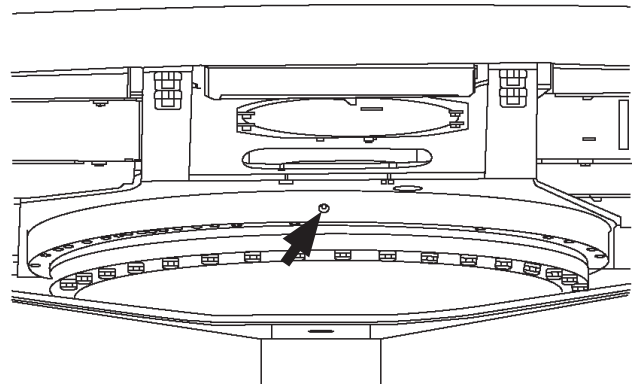

MDCR-07-015

## MAINTENANCE

### 3 Swing Internal Gear --- every 500 hours

**CAUTION:** Before lubricating the machine, lower the bucket on the ground, stop the engine and pull the pilot control shut-off lever to the LOCK position.

1. Remove cover (1) from upperstructure. Check if the swing internal gear is properly lubricated by grease.
2. Please insert the scale (2) and check that the height (H) of the grease amount of the swing internal gear is higher than the reference value.

Depending on the model, the height may be different depending on the inserted position. Please change the inserting position when the height is greatly different.

Model	Grease Height (H)
ZX135US-6	16 mm
ZX225USLC-6	5 mm
ZX345USLC-6	10 mm

3. If it is insufficient, replenish the grease, pay attention to the O-ring of the cover (1), install it downward, and then start the engine. Please check the height (H) of grease amount again after swinging a few times.

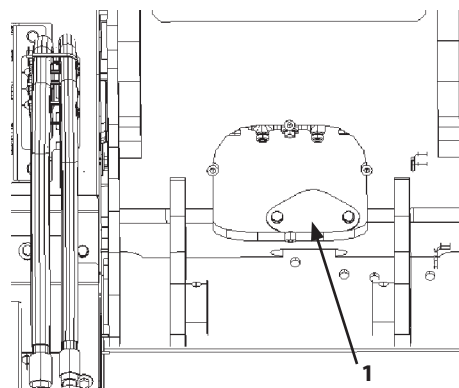

ZX135US-6

MDCN-07-012

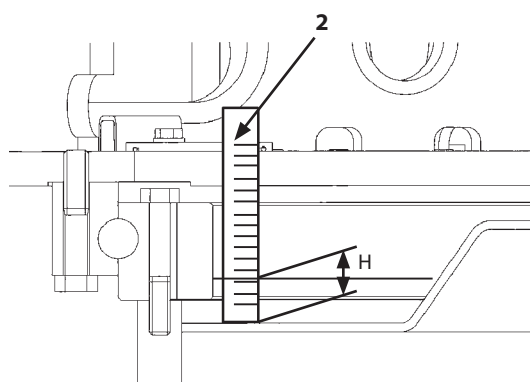

ZX135US-6

MDAT-07-079

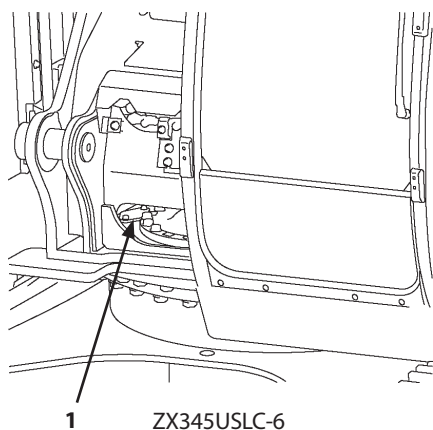

1

ZX345USLC-6

MDD5-07-005

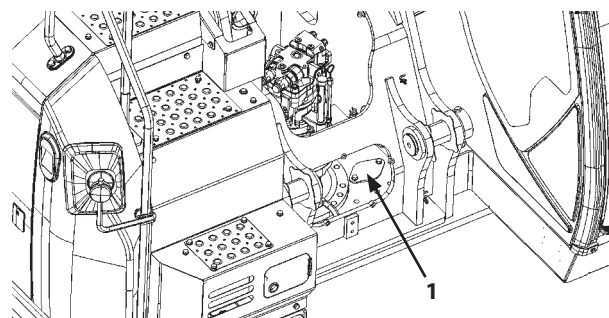

ZX225USLC-6

MDCN-07-013

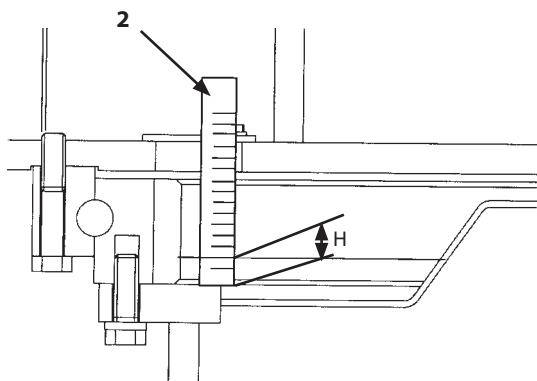

ZX345USLC-6

MDC1-07-102

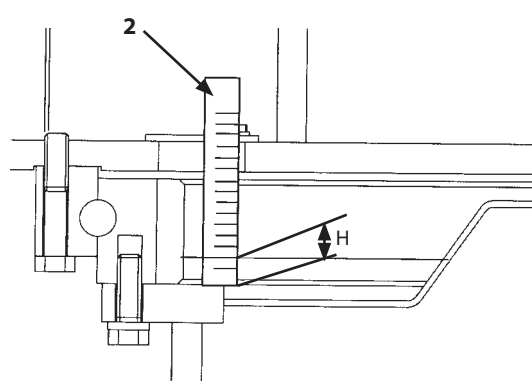

ZX225USLC-6

MDC1-07-102



## MAINTENANCE

---

If the grease is contaminated, remove grease by opening cover (3) at the undercarriage side and change with clean grease.

Model	Grease Capacity
ZX135US-6	9 L
ZX225USLC-6	17 L
ZX345USLC-6	19 L

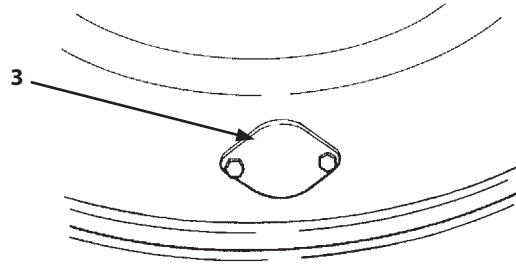

M157-07-161

## MAINTENANCE

---

### Electric Grease Gun (Nickel-Cadmium Battery) (Only ZX345US-6 class)

#### CAUTION:

- Since the electric grease gun is not a water-resistance type, avoid leaving it in a place exposed to rain and water. Do not use the electric grease gun in rain fall. Failure to do so may lead to an unexpected accident such as leak.
- No specified daily maintenance is required. Take care not to allow any part of the grease gun, especially motor section, to come in contact with other objects or do not leave the grease gun contaminated, possibly resulting in unexpected injury such as electric shock.
- Always keep the grease gun clean by wiping off contamination. Failure to do so may cause the grease gun to slip down resulting in possible personal injury.

#### WARNING:

- Do not operate an electric grease gun in explosive atmosphere.
- An electric tool may create sparks and ignite combustible fluid, dust, or fumes.
- Avoid electrifying the grease gun in damp or wet locations.
- The high pressure of the grease gun is different for each grease gun. Use goggles and heavy gloves for protection during operation.
  - Normal/Nickel-cadmium battery type: 41.4 MPa (422 kgf/cm<sup>2</sup>)
  - Lithium-ion battery type: 55.1 MPa (562 kgf/cm<sup>2</sup>)

#### IMPORTANT:

- In case the grease gun becomes inoperable, do not continuously operate it further. Damage to the motor or a risk of fire may result.
- When a battery pack is not in use, store the battery pack keeping away from a metallic product such as a paper clip, coin, key, nail, or screw. Short circuit of the battery may create sparks leading to hazards such as burns, or fires.
- Always be sure to use the attached battery pack. Using a battery pack other than the attached one may cause a risk of fire.
- Supply the power to the battery charger through the lighter receptacle with the output of 12 V or 24 V.

## MAINTENANCE

---

### IMPORTANT:

- **Do not use the attached battery charger except for charging the attached battery pack. If a battery other than the attached one is charged personal injury and damage may result due to explosion. Never attempt to charge the attached battery pack by a battery charger other than attached one under any circumstances.**
- **Prevent the battery charger from being exposed to rain, snow or frost.**
- **Do not abuse the cord. Never carry the battery charger with the cord. Take care not to break the cord by pulling it from the receptacle.**

**When disconnecting the battery charger, pull on the plug. Do not pull the cord. Immediately replace the damaged or worn power cord and the damaged relief valve. Do not operate the battery charger with a damaged cord or plug connected. Never attempt to repair the power cord.**
- **Do not disassemble the battery charger and/or battery pack. Risk of electric shock or fire may result if incorrectly reassembled.**
- **Do not incinerate the battery pack. It can explode in a fire.**
- **Never attempt to charge any other cordless tool or battery pack with this battery charger.**
- **Never short-circuit between the battery terminals. Damage and/or fires may result due to effect of very high temperature.**
- **Properly dispose the expended battery pack. The battery pack is a chargeable nickel-cadmium battery. This type of battery is required to be recycled or disposed of in a proper method. Drop off the expended battery pack at your local replacement battery retailer or your recycling center.**
- **Do not store the battery charger and/or battery pack in locations where the atmospheric temperature may reach or exceed more than 50°C. The battery pack will deteriorate.**

## MAINTENANCE

---

### Electric Grease Gun

#### Specifications

Operating voltage	12 V
Maximum operating pressure	41.4 MPa (422 kgf/cm <sup>2</sup> )
Grease cartridge capacity	411 cc
Operating temperature range	-18 to 50 ° C
Operating current (at pressure 6.9 MPa (70 kgf/cm <sup>2</sup> ))	4 A
Grease	Consistency: 2 or less
Grease delivery flow (at pressure 6.9 MPa (70 kgf/cm <sup>2</sup> ))	194 cc/minute
Weight	3.76 kg

#### Attachments

##### Battery pack

Output voltage	12 V
Capacity	1300 mAh

##### Charger

Charge time	1 hour
Output voltage ( at1.7 A)	14.5 V
Input voltage (at 350 mA)	100 V, 50 Hz

# MAINTENANCE

## Components Name

- 1- Switch
- 2- Motor assembly
- 3- Nozzle (CNP-2)
- 4- Cap
- 5- Cartridge grease
- 6- Oil barrel
- 7- Chain (Lever)
- 8- Battery pack
- 9- Battery charger
- 10- Code
- 11- Plug
- 12- Band
- 13- Holding bracket

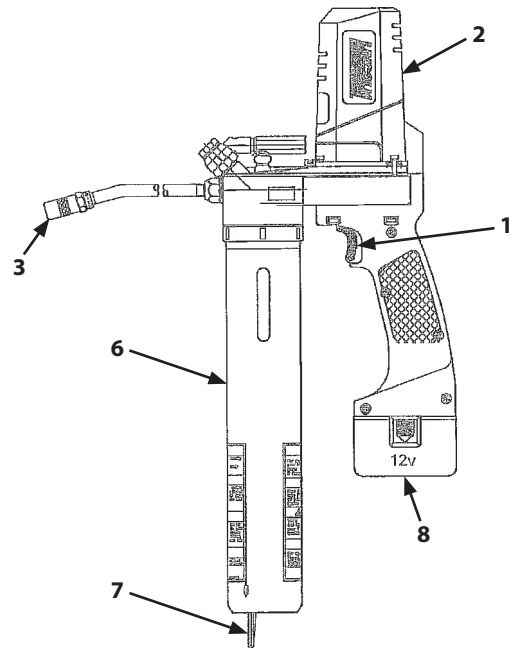

M1U1-07-115

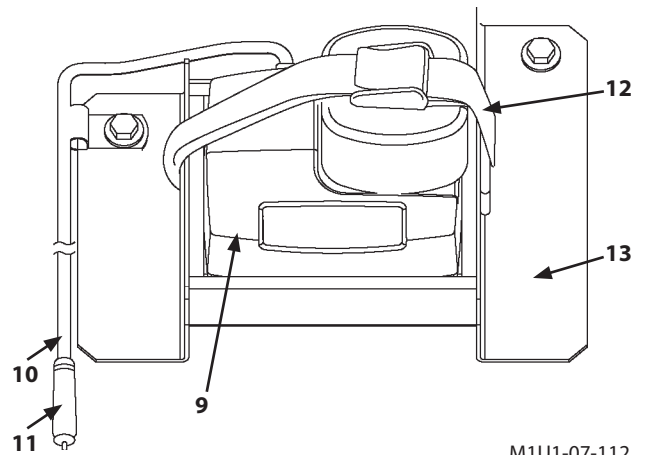

M1U1-07-112

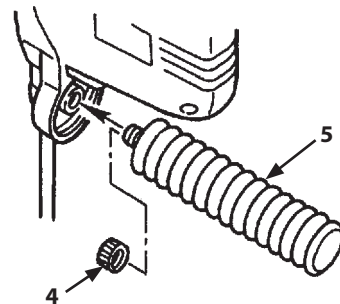

M16J-07-043

## MAINTENANCE

---

### Battery Charger Operation

#### Charging the Battery Pack General

Before using an electric grease gun for the first time, charge the battery pack. (for approx. 12 hours)

Refer to the descriptions on "Install/remove Battery Pack" for installing the battery pack to the electric grease gun.

When the battery pack is almost discharged, the battery performance sharply drops.

In case greasing becomes difficult, it indicates the time to recharge the battery pack.

If the battery is recharged before this condition is reached, the total work life of the battery pack is reduced.

 **NOTE:** *The battery pack temperature will increase during or immediately after operation. Do not recharge the battery pack soon after operation. The battery pack may not be fully recharged. Recharge the battery pack only after the battery pack temperature is approximately lowered to room temperature.*

 **CAUTION:** **Do not plug the vent holes at the top and bottom of the battery charger. When the atmospheric temperature is below 0°C or above 40°C, do not charge the battery pack.**

### Charger Lamps

1. Green LED lit.

This indicates the battery pack is fully charged.

2. Green LED flashes.

This indicates the battery pack is charging.

3. Red LED flashes.

This indicates the battery pack is unusable due to the end of its service life or some other problem and should be replaced.

4. Red LED blinks or lights up repeatedly.

If the recharge environment is excessively hot or cold, the charger stops charging. When the charger is in a suitable charging environment, it starts charging automatically.

## MAINTENANCE

---

### **Normal Charging Method**

After checking that the power source voltage meets the voltage shown on the battery charger specification, connect the battery charger plug to the power source.

The first time the electric grease gun is used, it must be charged for 12 hours or more. Install the battery pack in the battery charger.

Disconnect the battery charger plug from the power source after using the battery charger.

### **Installing/Removing Battery Pack**

#### Removing Battery Pack

Press the battery release button on the battery pack and pull out the battery pack out of the electric grease gun.

#### Installing Battery Pack

After aligning the battery pack with the specified location on the electric grease gun handle, push the battery pack into the handle until it locks in place.

## MAINTENANCE

### Lubricating with the Electric Grease Gun

Installing cartridge grease

**IMPORTANT:** Take care not to allow sand and/or dust to mix in grease when installing cartridge grease (5).

1. Turn to remove oil barrel (6) from motor assembly (2).
2. Fully pull out chain (7) from oil barrel (6). Attach chain (7) to a notch on the bottom of oil barrel (6).
3. After removing cap (4) from cartridge grease (5), install cartridge grease (5) to the screw threads on motor assembly (2).

**IMPORTANT:** Be alert that if cartridge grease (5) is diagonally or forcibly screwed in, damage to the screw threads may result so that the cartridge grease may not be installed to motor assembly (2).

4. Screw oil barrel (6) in the original position on motor assembly (2). Detach chain (7) from the notch.

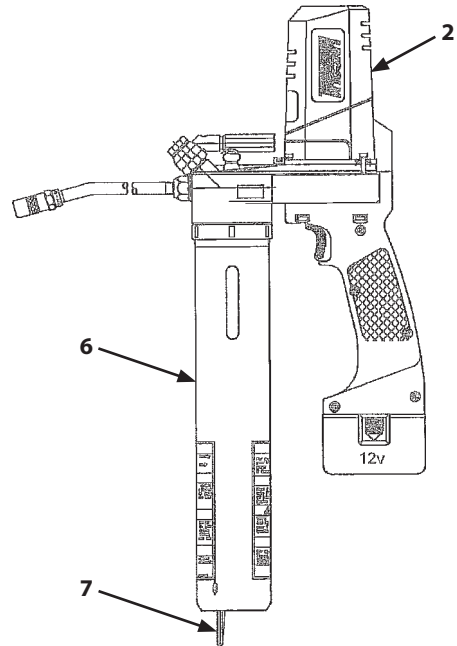

M1U1-07-115

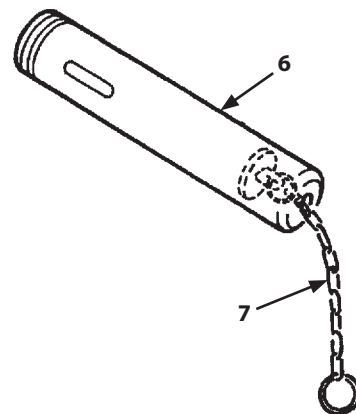

M16J-07-042

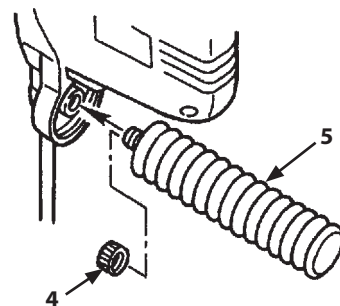

M16J-07-043



## MAINTENANCE

### Greasing Method

**IMPORTANT:** When lubricating a closed space with grease, the motor rotation becomes slow as soon as grease is sufficiently filled in the lubrication space. End greasing by releasing switch (1). If greasing is continued further, burning of the motor may result.

1. Drive the motor by pulling switch (1). Grease is discharged from the tip of nozzle (3).

 **NOTE:** When the grease gun is first used, it takes some time before discharging grease until air is bled from the motor assembly.

2. After cleanly wiping the tips of the grease fitting through which grease is added and gun nozzle (3), press the tip of nozzle (3) to chuck the grease fitting.
3. Pull switch (1) to discharge grease.  
When grease is normally added, old grease is discharged through the clearance around the grease fitting.
4. After completing greasing, allow the inner pressure to release from the grease fitting by tilting nozzle (3) before disconnecting the tip of nozzle (3) from the grease fitting.

Certain amount of grease escapes at this time.

-  **NOTE:**
- If the motor rotation becomes very slow or stops during greasing, immediately release switch (1).
  - The electric grease gun is a high speed type so that slight amount of grease may escape from the plunger. This is not a fault.

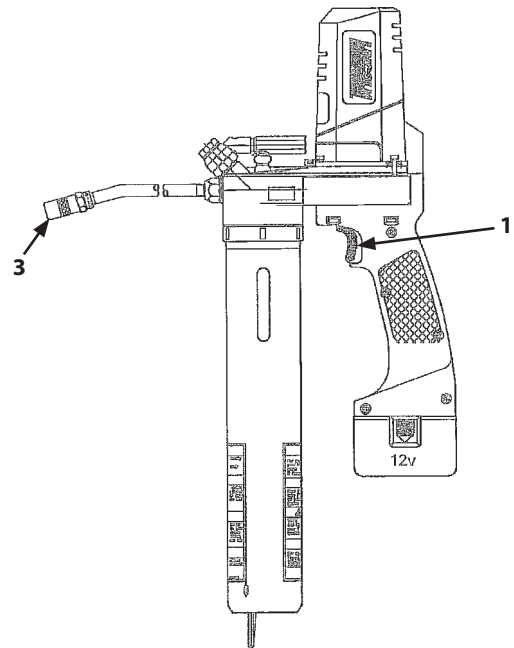

M1U1-07-115

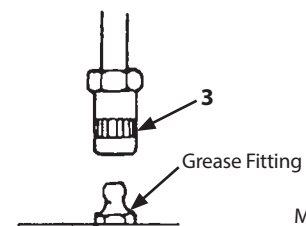

M16J-07-045

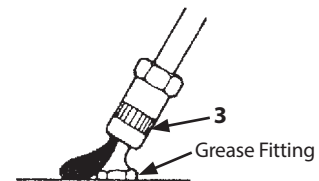

M16J-07-046

## MAINTENANCE

---

### Warnings After Use

**IMPORTANT:** Securely fasten the single battery charger or the battery charger with the battery pack installed to the holding bracket with a band attached to the holding bracket so that the battery charger and/or the battery pack does not come off the bracket. Failure to do so may cause the battery pack and/or battery charger to come off the holding bracket, possibly resulting in damage to the battery pack and/or battery charger.

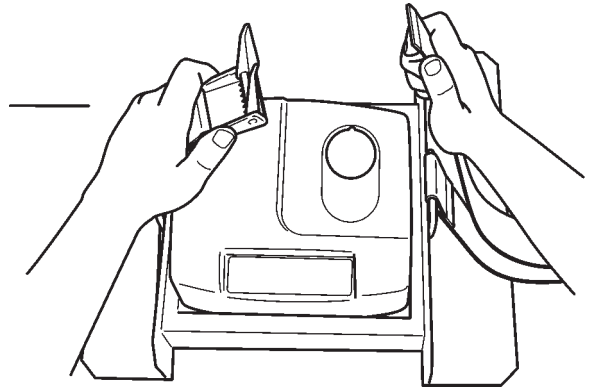

M1U1-07-061

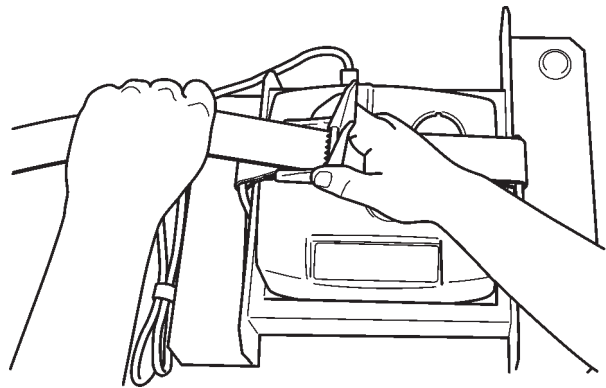

M1U1-07-062

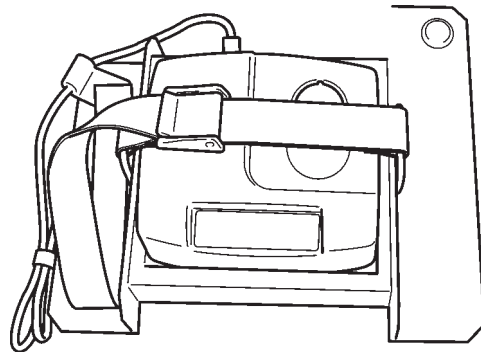

M1U1-07-063

## MAINTENANCE

---

### Electric Grease Gun (Lithium-ion Battery) (Only ZX345US-6 class)

#### CAUTION:

- Since the electric grease gun is not a water-resistance type, avoid leaving it in a place exposed to rain and water. Do not use the electric grease gun in rain fall. Failure to do so may lead to an unexpected accident such as leak.
- No specified daily maintenance is required. Take care not to allow any part of the grease gun, especially motor section, to come in contact with other objects or do not leave the grease gun contaminated, possibly resulting in unexpected injury such as electric shock.
- Always keep the grease gun clean by wiping off contamination. Failure to do so may cause the grease gun to slip down resulting in possible personal injury.

#### WARNING:

- Do not operate an electric grease gun in explosive atmosphere.
- An electric tool may create sparks and ignite combustible fluid, dust, or fumes.
- Avoid electrifying the grease gun in damp or wet locations.
- The high pressure of the grease gun is different for each grease gun. Use goggles and heavy gloves for protection during operation.
  - Normal/Nickel-cadmium battery type: 41.4 MPa (422 kgf/cm<sup>2</sup>)
  - Lithium-ion battery type: 55.1 MPa (562 kgf/cm<sup>2</sup>)

#### IMPORTANT:

- In case the grease gun becomes inoperable, do not continuously operate it further. Damage to the motor or a risk of fire may result.
- When a battery pack is not in use, store the battery pack keeping away from a metallic product such as a paper clip, coin, key, nail, or screw. Short circuit of the battery may create sparks leading to hazards such as burns, or fires.
- Always be sure to use the attached battery pack. Using a battery pack other than the attached one may cause a risk of fire.
- Supply the power to the battery charger through the lighter receptacle with the output of 12 V or 24 V.

## MAINTENANCE

---

### IMPORTANT:

- **Do not use the attached battery charger except for charging the attached battery pack. If a battery other than the attached one is charged personal injury and damage may result due to explosion. Never attempt to charge the attached battery pack by a battery charger other than attached one under any circumstances.**
- **Prevent the battery charger from being exposed to rain, snow or frost.**
- **Do not abuse the cord. Never carry the battery charger with the cord. Take care not to break the cord by pulling it from the receptacle.**

**When disconnecting the battery charger, pull on the plug. Do not pull the cord. Immediately replace the damaged or worn power cord and the damaged relief valve. Do not operate the battery charger with a damaged cord or plug connected. Never attempt to repair the power cord.**
- **Do not disassemble the battery charger and/or battery pack. Risk of electric shock or fire may result if incorrectly reassembled.**
- **Do not incinerate the battery pack. It can explode in a fire.**
- **Never attempt to charge any other cordless tool or battery pack with this battery charger.**
- **Never short-circuit between the battery terminals. Damage and/or fires may result due to effect of very high temperature.**
- **Properly dispose the expended battery pack. The battery pack is a chargeable lithium-ion battery. This type of battery is required to be recycled or disposed of in a proper method. Drop off the expended battery pack at your local replacement battery retailer or your recycling center.**
- **Do not store the battery charger and/or battery pack in locations where the atmospheric temperature may reach or exceed more than 50°C. The battery pack will deteriorate.**

## MAINTENANCE

---

### Electric Grease Gun

#### Specifications

Operating voltage	12 V DC
Maximum operating pressure	55.1 MPa (562 kgf/cm <sup>2</sup> )
Grease cartridge capacity	411 cc
Operating temperature range	-10 to 50 ° C
Operating current (at pressure 6.9 MPa (70 kgf/cm <sup>2</sup> ))	5 A
Grease	Consistency: 2 or less
Grease delivery flow (at pressure 6.9 MPa (70 kgf/cm <sup>2</sup> ))	76.3 cc/minute
Weight	2.86 kg

#### Attachments

##### Battery pack

Output voltage	12 V
Capacity	1500 mAh

##### Charger

Charge time	40 minute
Output voltage (at 1.0 A)	20 V DC
Input voltage (at 3.0 A)	12-24 V DC

# MAINTENANCE

## Components Name

- 1- Switch
- 2- Motor assembly
- 3- Nozzle (CNP-2)
- 4- Cap
- 5- Cartridge grease
- 6- Oil barrel
- 7- Chain (Lever)
- 8- Battery pack
- 9- Battery charger
- 10- Code
- 11- Plug
- 12- Band
- 13- Holding bracket

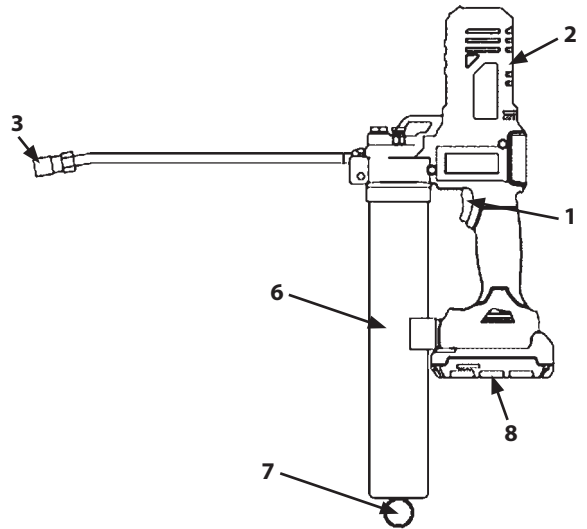

MJAG-13-011

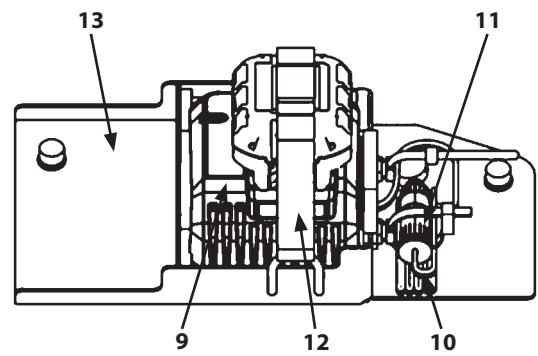

MJAG-13-012

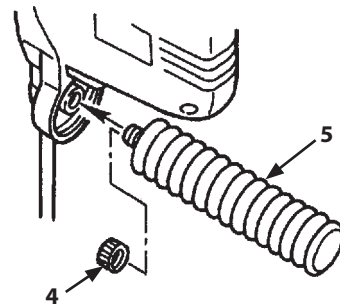

M16J-07-043

## MAINTENANCE

---

### Battery Charger Operation

#### Charging the Battery Pack General

Before using an electric grease gun for the first time, charge the battery pack. (for approx. 12 hours)

Refer to the descriptions on "Install/remove Battery Pack" for installing the battery pack to the electric grease gun.

When the battery pack is almost discharged, the battery performance sharply drops.

In case greasing becomes difficult, it indicates the time to recharge the battery pack.

If the battery is recharged before this condition is reached, the total work life of the battery pack is reduced.

 **NOTE:** *The battery pack temperature will increase during or immediately after operation. Do not recharge the battery pack soon after operation. The battery pack may not be fully recharged. Recharge the battery pack only after the battery pack temperature is approximately lowered to room temperature.*

 **CAUTION:** **Do not plug the vent holes at the top and bottom of the battery charger. When the atmospheric temperature is below 0°C or above 40°C, do not charge the battery pack.**

### Charger Lamps

1. Green LED lit.

This indicates the battery pack is fully charged.

2. Green LED flashes.

This indicates the battery pack is charging.

3. Red LED flashes.

This indicates the battery pack is unusable due to the end of its service life or some other problem and should be replaced.

4. Red LED blinks or lights up repeatedly.

If the recharge environment is excessively hot or cold, the charger stops charging. When the charger is in a suitable charging environment, it starts charging automatically.

## MAINTENANCE

---

### **Normal Charging Method**

After checking that the power source voltage meets the voltage shown on the battery charger specification, connect the battery charger plug to the power source.

The first time the electric grease gun is used, it must be charged for 12 hours or more. Install the battery pack in the battery charger.

Disconnect the battery charger plug from the power source after using the battery charger.

### **Installing/Removing Battery Pack**

#### Removing Battery Pack

Press the battery release button on the battery pack and pull out the battery pack out of the electric grease gun.

#### Installing Battery Pack

After aligning the battery pack with the specified location on the electric grease gun handle, push the battery pack into the handle until it locks in place.



## MAINTENANCE

### Lubricating with the Electric Grease Gun

Installing cartridge grease

**IMPORTANT:** Take care not to allow sand and/or dust to mix in grease when installing cartridge grease (5).

1. Turn to remove oil barrel (6) from motor assembly (2).
2. Fully pull out chain (7) from oil barrel (6). Attach chain (7) to a notch on the bottom of oil barrel (6).
3. After removing cap (4) from cartridge grease (5), install cartridge grease (5) to the screw threads on motor assembly (2).

**IMPORTANT:** Be alert that if cartridge grease (5) is diagonally or forcibly screwed in, damage to the screw threads may result so that the cartridge grease may not be installed to motor assembly (2).

4. Screw oil barrel (6) in the original position on motor assembly (2). Detach chain (7) from the notch.

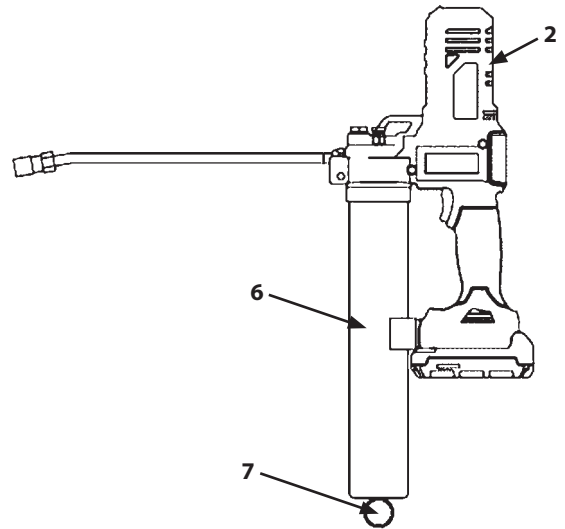

MJAG-13-011

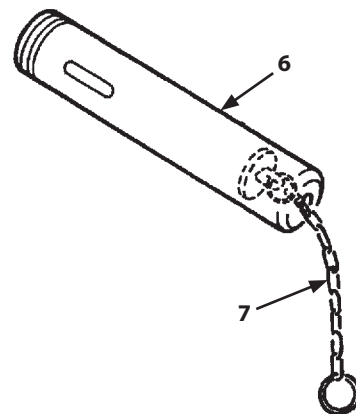

M16J-07-042

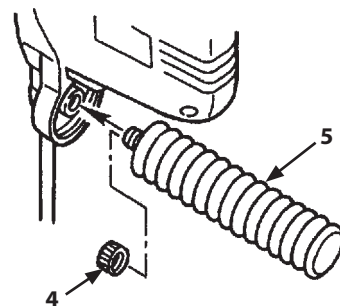

M16J-07-043

## MAINTENANCE

### Greasing Method

**IMPORTANT:** When lubricating a closed space with grease, the motor rotation becomes slow as soon as grease is sufficiently filled in the lubrication space. End greasing by releasing switch (1). If greasing is continued further, burning of the motor may result.

1. Drive the motor by pulling switch (1). Grease is discharged from the tip of nozzle (3).

 **NOTE:** When the grease gun is first used, it takes some time before discharging grease until air is bled from the motor assembly.

2. After cleanly wiping the tips of the grease fitting through which grease is added and gun nozzle (3), press the tip of nozzle (3) to chuck the grease fitting.

3. Pull switch (1) to discharge grease.

When grease is normally added, old grease is discharged through the clearance around the grease fitting.

4. After completing greasing, allow the inner pressure to release from the grease fitting by tilting nozzle (3) before disconnecting the tip of nozzle (3) from the grease fitting.

Certain amount of grease escapes at this time.

 **NOTE:**

- If the motor rotation becomes very slow or stops during greasing, immediately release switch (1).
- The electric grease gun is a high speed type so that slight amount of grease may escape from the plunger. This is not a fault.

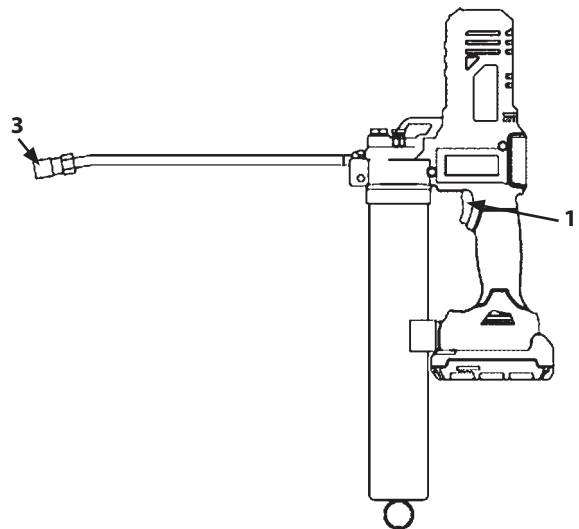

MJAG-13-011

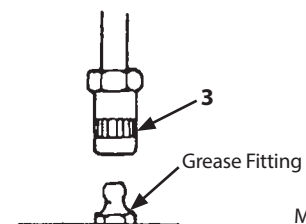

M16J-07-045

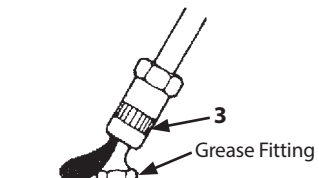

M16J-07-046

## MAINTENANCE

---

### Warnings After Use

**IMPORTANT:** Securely fasten the single battery charger or the battery charger with the battery pack installed to the holding bracket with a band attached to the holding bracket so that the battery charger and/or the battery pack does not come off the bracket. Failure to do so may cause the battery pack and/or battery charger to come off the holding bracket, possibly resulting in damage to the battery pack and/or battery charger.

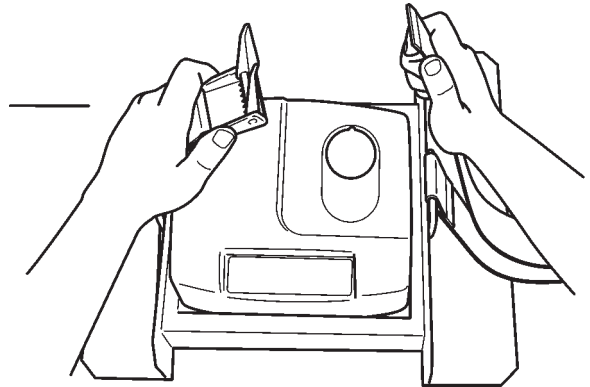

M1U1-07-061

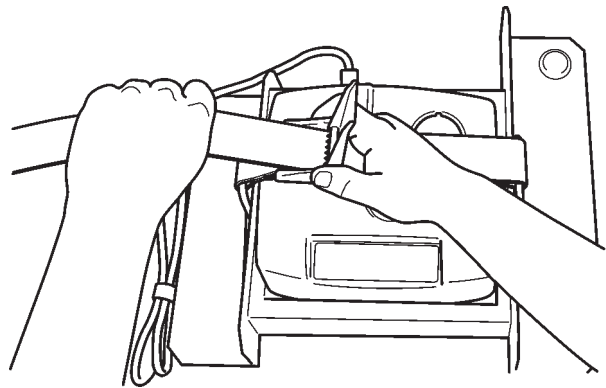

M1U1-07-062

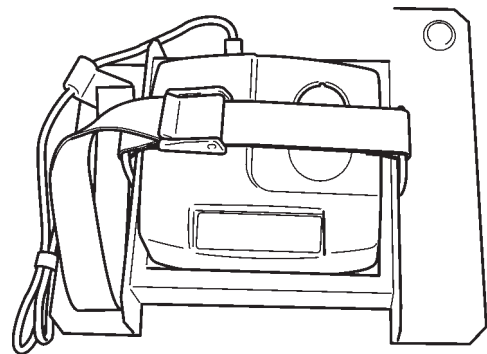

M1U1-07-063

# MAINTENANCE

## B. Engine

### 1 Check Engine Oil Level ---daily

1. Confirm that pilot control shut-off lever (1) is in the LOCK position.
2. Confirm that all control levers are placed in neutral.
3. Insert key (2) into the key switch. Turn it to ON position. Press and hold switch (3) with the engine stopped.

The engine oil level indicator (4) must be displayed in green.

**IMPORTANT:** Do not rely only on the monitor display for checking the machine conditions; visually check them yourself as required such as oil level.

**Always check the machine on a firm, level surface.**

 **NOTE:** If the security function is enabled, a password is required.

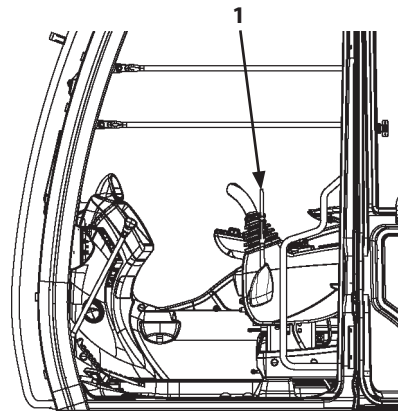

LOCK position

MDAA-01-295

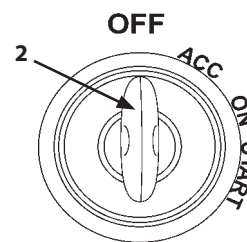

MDC1-01-502

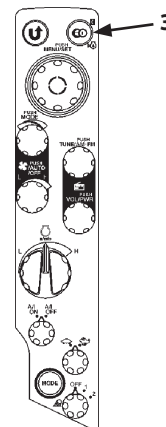

MDCD-01-026

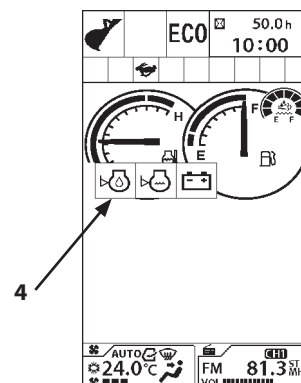

MDC1-01-041

## MAINTENANCE

### --- Visual Inspection

**IMPORTANT:** Incorrect engine oil level may cause trouble in the engine (The oil level should be between the upper and lower marks on dipstick (1)).

Even if the engine oil level exceeds the upper limit, maintain oil to the proper level before starting the engine.

Check oil level before starting the engine.

Open the engine cover and pull out dipstick (1). Wipe dipstick (1) with cloth, re-insert it into the pipe to the end, and then pull it out again.

The oil level should be between the upper and lower marks on dipstick (1).

If oil level is below the lower limit mark, add the recommended engine oil via oil filler (2).

If oil level exceeds the upper limit mark, remove cap (4) of drain valve (3) at the bottom of the engine oil pan, and then open drain valve (3) by turning drainer (5) to drain oil.

**CAUTION:** Avoid spillages while changing oil. Spilled fuel and oil, trash, grease, debris, accumulated coal dust, and other flammable materials may cause fires.

After refilling, make sure oil filler cap (2) is securely closed.

**IMPORTANT:** Install drainer (5) to drain valve (3) slowly. Oil may exhaust in large quantity when tightened at once.

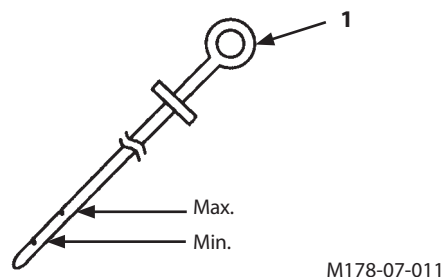
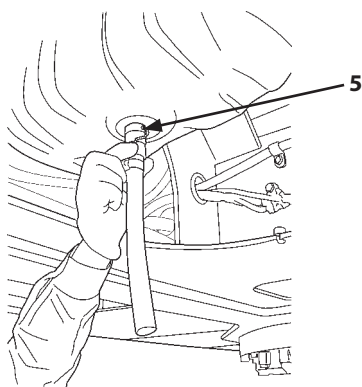
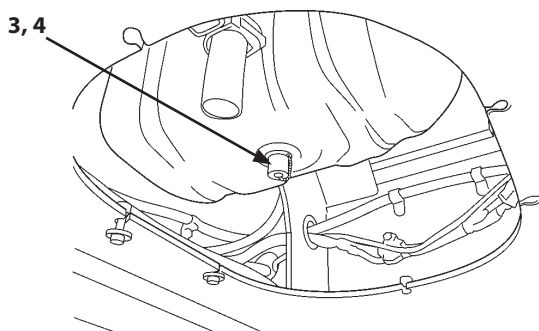
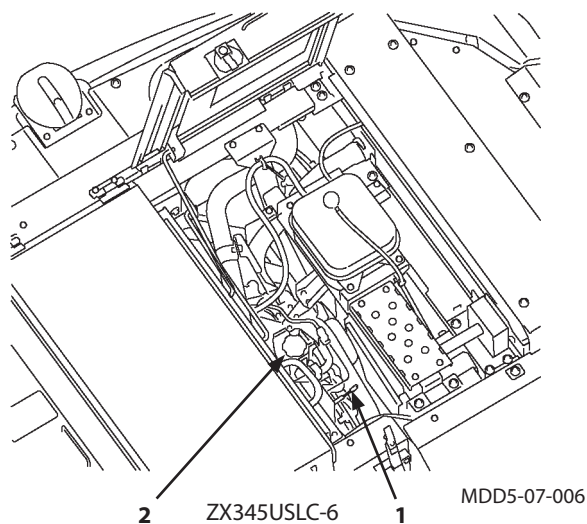
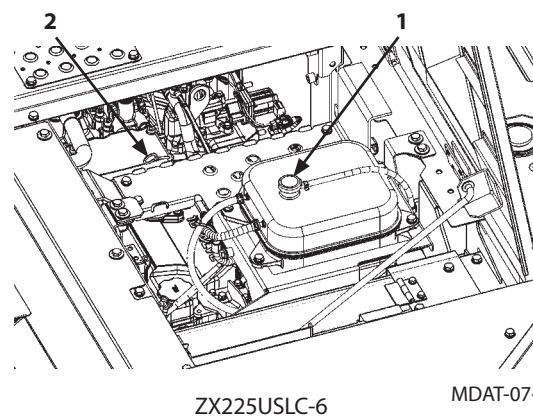
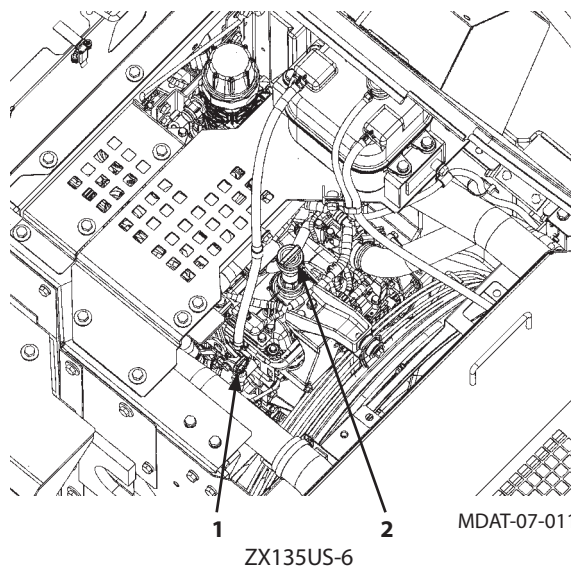

## MAINTENANCE

**2** Change Engine Oil  
--- every 500 hours

**3** Replace Engine Oil Filter  
--- every 500 hours

**CAUTION:** Engine oil may be hot just after operation.  
Take extra care to avoid burns.

After refilling, make sure oil filler cap (2) is securely closed.

1. Run the engine to warm oil.  
DO NOT run the engine until oil is hot.
2. Park the machine on a firm, level surface.
3. Lower the bucket to the ground.
4. Turn the auto-idle switch off.

**IMPORTANT:** The turbocharger may be damaged if the engine is not properly shut down.

5. Run the engine at slow idle speed without load for 5 minutes.
6. Turn the key switch OFF. Remove the key from the key switch.
7. Pull the pilot control shut-off lever to the LOCK position.

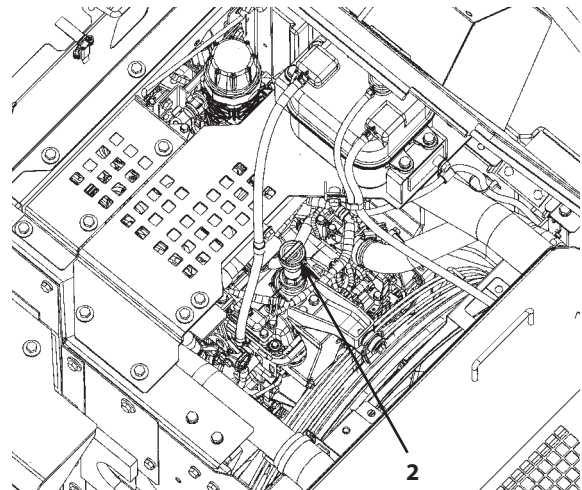

ZX135US-6

MDAT-07-011

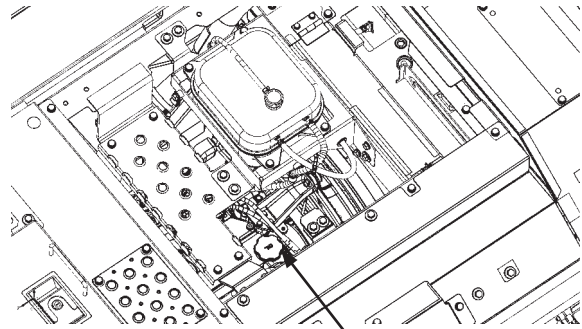

ZX225USLC-6

MDAT-07-012

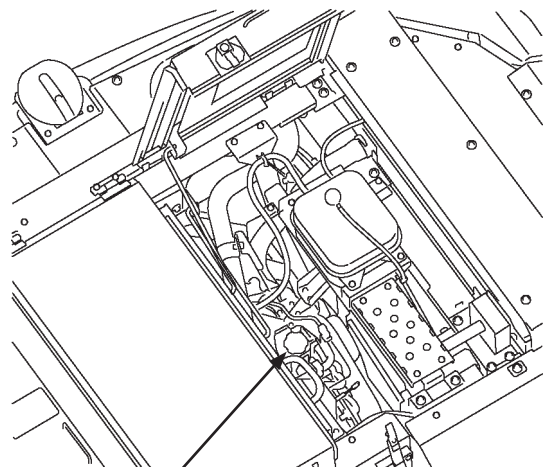

ZX345USLC-6

MDD5-07-006

## MAINTENANCE

**IMPORTANT: Install drainer (5) to drain valve (3) slowly.  
Oil may exhaust in large quantities when suddenly  
tightened.**

8. Remove oil filler cap (2).
9. Remove cap (4) from oil pan drain valve (3). Install drainer (5) to drain valve (3).
10. Screw drainer (5) into drain valve (3). Drain valve (3) will be opened to drain oil.
11. Then, allow oil to drain through a clean cloth into a container.

Container: 50-liter

12. After all oil has been drained, inspect the cloth for any debris such as small pieces of metal.
13. Remove drainer (5). Install cap (4) to drain valve (3).

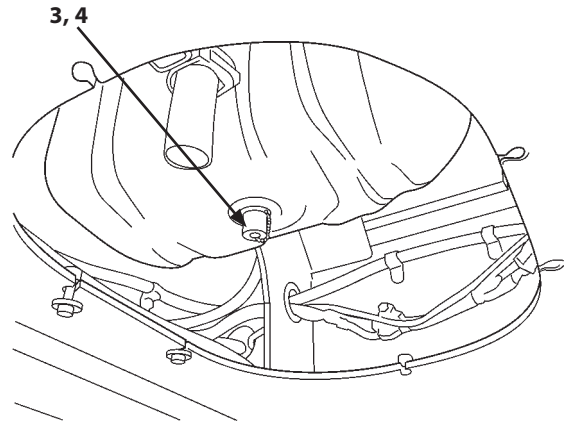

M1U1-07-045

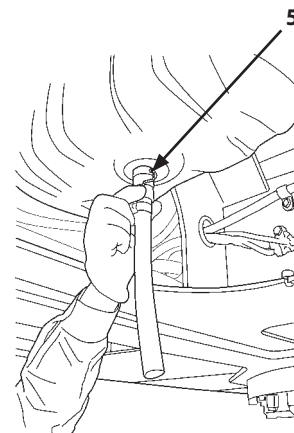

M1U1-07-046

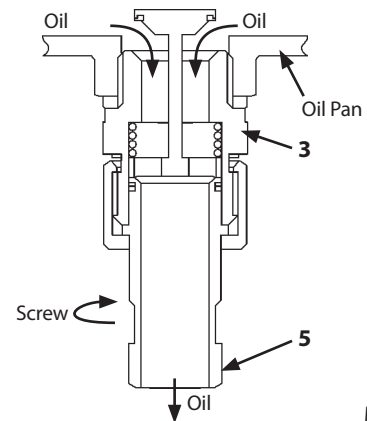

M1U1-07-002

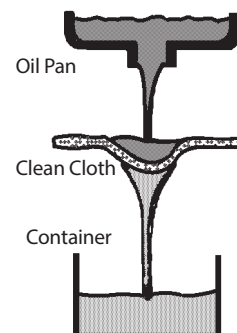

M104-07-010



## MAINTENANCE

14. Open the right access cover and secure the cover with rod.
15. Remove engine oil filter (6) by turning it counterclockwise with the filter wrench.
16. Clean filter (6) gasket contact area on the engine.
17. Put new oil in from primary side (7) of new cartridge element (6) so it does not overflow. Take care not to insert it from secondary side (8).
18. Install new filter (6). Turn filter (6) clockwise by hand until the gasket touches the contact area. Be sure not to damage the gasket when installing filter (6).
19. Tighten engine oil filter (6) 3/4 to 1 turn further using the filter wrench. Be careful not to overtighten.
20. Fill the engine with recommended oil. Check that oil level is between the circle marks on the dipstick after 15 minutes.
21. Install the oil filler cap.
22. Start the engine. Run the engine at slow idle for 5 minutes.
23. Check that the engine oil pressure indicator on the monitor panel goes out immediately. If not, stop the engine immediately and find the cause.
24. Stop the engine. Remove the key from the key switch.
25. Check for any leakage at the drain plug.
26. Check oil level on the dipstick and add or drain oil to maintain proper oil level. (The oil level should be between the upper and lower limit marks on the oil level gauge.) (Refer to the page 7-54)

### IMPORTANT:

- **When putting new oil in cartridge element (6), take care that no foreign objects get in from secondary side (8).**
- **Do not re-use filter (6).**
- **Incorrect engine oil level may cause trouble in the engine. Even if the engine oil level exceeds the upper limit, control the oil level to the proper quantity before starting the engine.**
- **Do not overtighten the engine oil pan mounting bolts of ZX135US-6 machine. Failure to do so may damage the packing seal.**

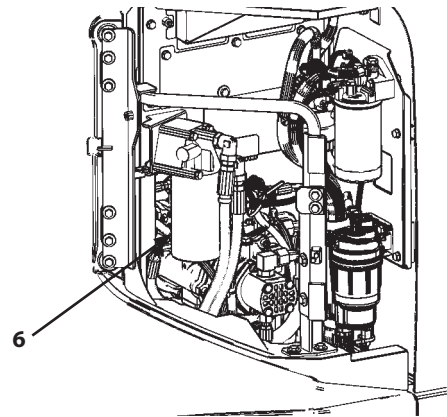

ZX135US-6

MDAT-07-013

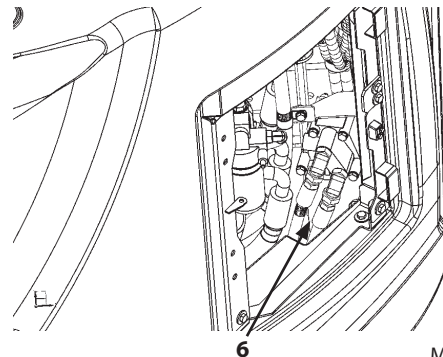

ZX225USLC-6

MDAT-07-014

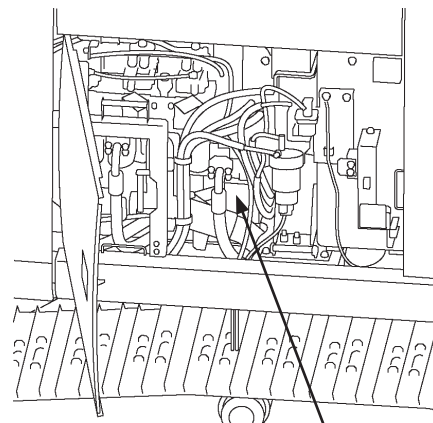

ZX345USLC-6

6

MDD5-07-007

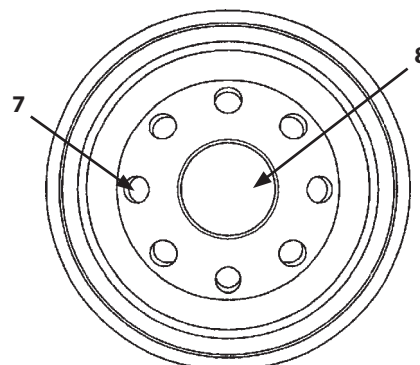

MDCR-07-007



## MAINTENANCE

---

### Sampling the Engine Oil (Only ZX225USLC-6)

 **NOTE:** The line is equipped with a valve (10) for sampling the engine oil. The valve has a cap (9). For instructions on sampling the engine oil, consult your authorized dealer.

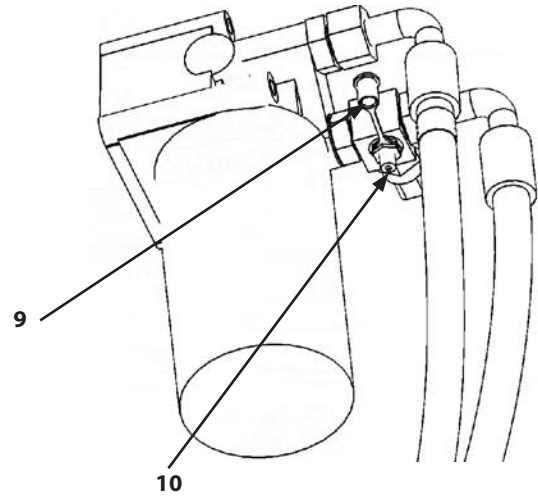

MDC1-07-112

## MAINTENANCE

### 4 Check and Clean Around the Engine

----- as required

**IMPORTANT:** Check for flammable materials in the area around the engine and clean that area.

When the machine is operated in dusty areas, refer to the page 9-1 "Maintenance Under Special Environmental Conditions".

### 5 Replace Oil Separator Element (Only ZX135US-6)

----- every 2500 hours

**CAUTION:** The oil separator becomes hot during operation. Severe burns may result if skin comes in contact with the oil separator immediately after operation. Wait for the oil separator to cool before starting any maintenance work.

**IMPORTANT:** To prevent foreign matter from entering, clean cap (3) and its surround before replacing oil separator element (1).

1. Park the machine on solid and level ground with the bucket cylinder fully extended and the arm cylinder fully retracted. Lower the bucket on the ground. Stop the engine
2. Remove the cap by twisting it counterclockwise.
3. Remove the oil separator element and O-ring (2). Replace them with new ones.
4. Securely tighten the cap by twisting it clockwise by hand.

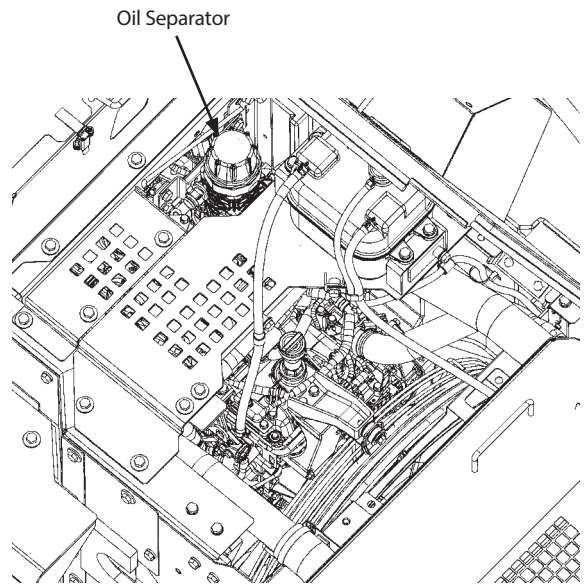

MDAT-07-011

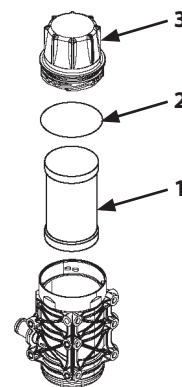

MDC1-07-079

## MAINTENANCE

### C. Transmission

#### 1 Pump Transmission (Except ZX135US-6)

##### Check Oil Level --- every 250 hours

1. Park the machine on a firm, level surface.
2. Lower the bucket to the ground.
3. Turn the auto-idle switch off.

**IMPORTANT: The turbocharger may be damaged if the engine is not properly shut down.**

4. Run the engine at slow idle speed without load for 5 minutes.
5. Stop the engine. Remove the key from the key switch.
6. Pull the pilot control shut-off lever to the LOCK position.
7. Remove dipstick (1). Oil must be within the specified range.
8. If necessary, remove filler plug (2) and add oil. (See gear oil chart)
9. Recheck oil level.

##### Change Oil --- every 1000 hours

##### Air Breather Cleaning --- every 1000 hours

**CAUTION: Oil may be hot just after operation. Wait for oil to cool before starting work.**

1. Park the machine on a level surface.
2. Lower the bucket to the ground.
3. Turn the auto-idle switch off.

**IMPORTANT: The turbocharger may be damaged if the engine is not properly shut down.**

4. Run the engine at slow idle speed without load for five minutes.
5. Stop the engine. Remove the key from the key switch.
6. Pull the pilot control shut-off lever to the LOCK position.
7. Remove filler plug (2).
8. Remove drain plug (3). Allow oil to drain through a clean cloth into a 2-liter container.
9. After all oil has drained, inspect cloth for any debris such as small pieces of metal.
10. Reinstall drain plug (3).
11. Add oil via filler plug (2) until it is within the specified range on dipstick (1).
12. Reinstall filler plug (2).
13. Remove air breather (4) and perform cleaning. After cleaning, install air breather (4).

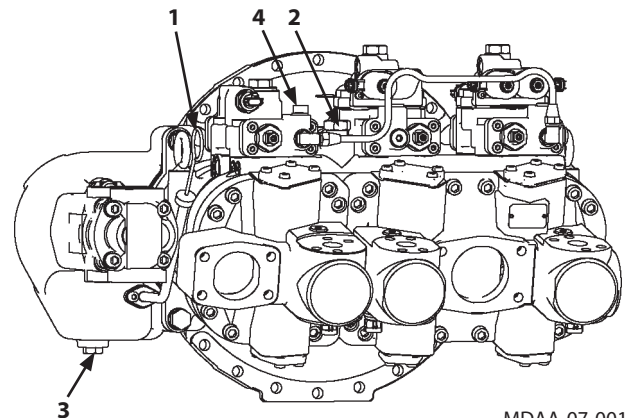

ZX225USLC-6

MDAA-07-001

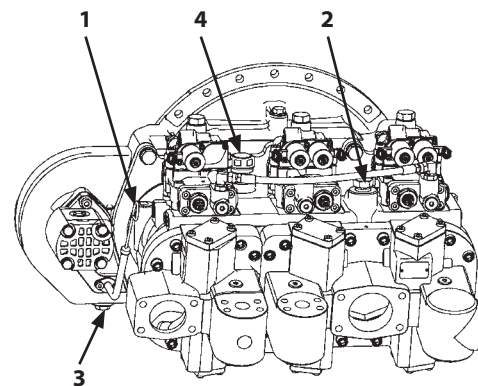

ZX345USLC-6

MDD5-07-051

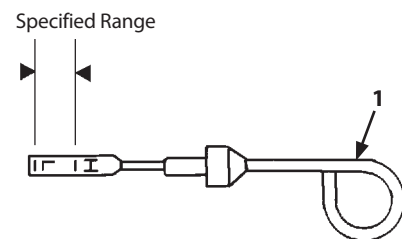

M1G6-07-004

# MAINTENANCE

## 2 Swing Reduction Gear

### Check Oil Level --- every 500 hours

1. Park the machine on a solid level surface. Lower the bucket to the ground. Stop the engine.

ZX135US-6

2. Turn over the level gauge rubber cover. Check level gauge (1).
3. When the oil level is correct, it can be seen between marks on level gauge (1). If necessary, remove the swing device upper cover and add oil.

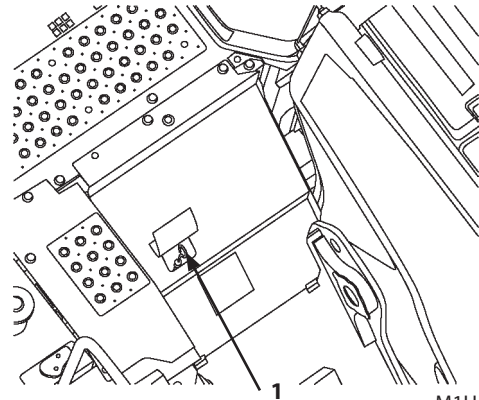

ZX135US-6

M1U4-07-044

ZX225USLC-6, 345USLC-6

2. Open the swing reduction upper cover. Check level gauge (1).
3. When the oil level is correct, it can be seen between marks on level gauge (1). If necessary, open the swing device upper cover and add oil.

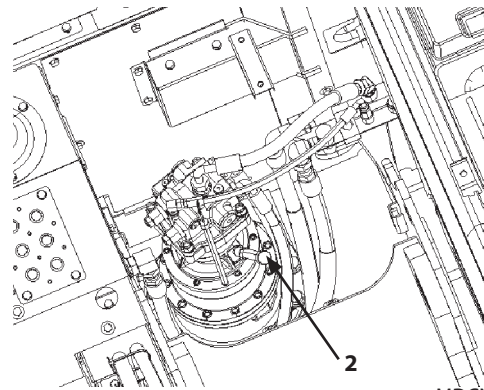

ZX135US-6

MDCN-07-018

### Change Gear Oil --- every 1000 hours

**CAUTION:** Gear oil may be hot just after operation. Wait for gear oil to cool before starting work.

1. Park the machine on a solid level surface. Lower the bucket to the ground. Stop the engine.
2. Remove the drain plug mounted on the end of drain pipe to drain oil.
- 3.

ZX135US-6

Reinstall the drain plug. Remove the swing device upper cover. Remove oil filler cap (2) and add oil.

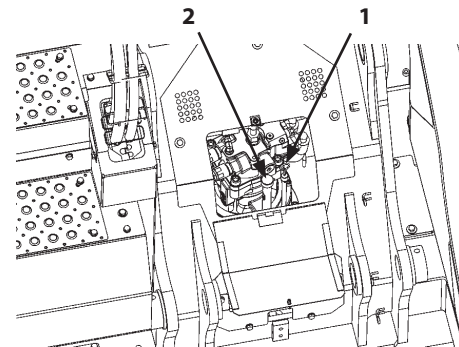

ZX225USLC-6

MDCN-07-019

ZX225USLC-6, 345USLC-6

Reinstall the drain plug. Open the swing device upper cover. Remove oil filler cap (2) and add oil.

4. Check oil level with level gauge (1). The oil level should be between the upper and lower marks on level gauge (1). Refill as necessary.

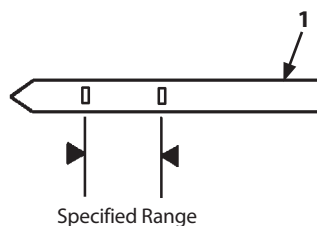

Specified Range

M104-07-017

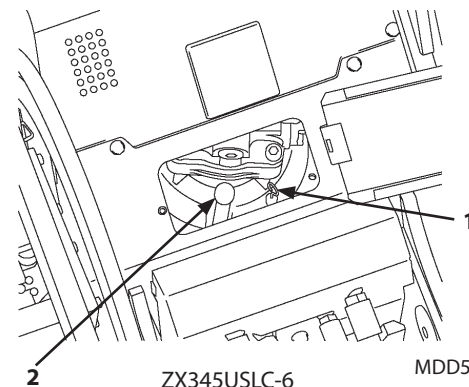

ZX345USLC-6

MDD5-07-008

## MAINTENANCE

### 3 Travel Reduction Gear

**CAUTION:** Keep body and face away from air release plug (1). Gear oil may be hot just after operation. Wait for gear oil to cool and then gradually loosen air release plug (1) to release pressure.

#### Check Oil Level --- every 500 hours

1. Park the machine on a firm, level surface.
2. Rotate the travel motor until the imaginary line through plug (1) and plug (3) are vertical.
3. Lower the bucket to the ground.
4. Turn the auto-idle switch off.

**IMPORTANT:** The turbocharger may be damaged if the engine is not properly shut down.

5. Run the engine at slow idle speed without load for 5 minutes.
6. Stop the engine. Remove the key from the key switch.
7. Pull the pilot control shut-off lever to the LOCK position.
8. After gear oil has cooled, slowly loosen air release plug (1) to release pressure.
9. Remove air release plug (1) and oil level check plug (2). Oil must be up to the bottom of hole.
10. If necessary, add oil until oil flows out of oil level check plug (2) hole. (See gear oil chart)
11. Wrap the plug threads with sealing-type tape. Install plugs (1) and (2).  
Tighten plugs (1) and (2) to 50 N·m (5.0 kgf·m).
12. Check the gear oil level in the other travel reduction gear.

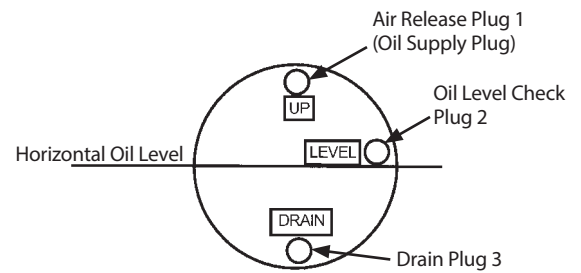

MDAA-07-047

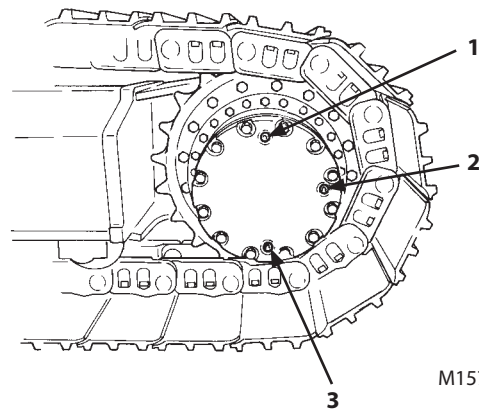

M157-07-170

## MAINTENANCE

### Change Gear Oil --- every 2000 hours

1. Park the machine on a firm, level surface.
2. Rotate the travel motor until the imaginary line through plug (1) and plug (3) are vertical.
3. Lower the bucket to the ground.
4. Turn the auto-idle switch off.

**IMPORTANT: The turbocharger may be damaged if the engine is not properly shut down.**

5. Run the engine at slow idle speed without load for 5 minutes.
6. Stop the engine. Remove the key from the key switch.
7. Pull the pilot control shut-off lever to the LOCK position.
8. After gear oil has cooled, slowly loosen air release plug (1) to release pressure, and temporarily retighten plug (1).
9. Remove drain plug (3) and plug (1), in that order, to drain oil.
10. Clean drain plug (3). Wrap the threads of drain plug (3) with sealing-type tape. Install plug (3). Tighten plug (3).  
Tightening Torque: 50 N·m (5.0 kgf·m)
11. Remove oil level check plug (2).
12. Add oil until oil flows out of oil level check plug (2) hole.  
(See gear oil chart)
13. Clean plugs (1) and (2). Wrap the threads of oil level check plug (2) and air release plug (1) with sealing-type tape. Reinstall the plugs (1) and (2). Tighten the plugs (1) and (2).  
Tightening Torque: 50 N·m (5.0 kgf·m)
14. Repeat steps 8. to 13. for the other travel reduction gear.

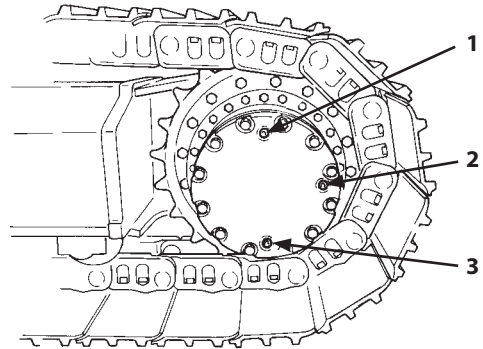

M157-07-170

# MAINTENANCE

---

## D. Hydraulic System

### Inspection and Maintenance of Hydraulic Equipment

**IMPORTANT:** Never adjust parts of engine fuel system or hydraulic equipment.

**CAUTION:** When checking and/or servicing the hydraulic components, pay special attention to the following points.

1. Be sure that the machine is parked on a level, firm surface before servicing hydraulic equipment.
2. Lower the bucket to the ground and stop the engine.
3. Begin servicing hydraulic components only after components, hydraulic oil and lubricants are completely cooled, and after releasing residual pressure.
  - 3.1 Before checking and/or servicing the hydraulic system, be sure to release the residual pressure from the cylinder circuits of the boom, arm and the bucket, swing piping and pilot piping. An accumulator can be installed on some models of this machine as an option to be capable of moving the front attachment for specified time (around 10 seconds) after stopping the engine.
  - 3.2 Bleed air from the hydraulic oil tank to release internal pressure.
  - 3.3 Immediately after operation, all hydraulic components and hydraulic oil or lubricants are hot and highly pressurized. Begin inspection and/or maintenance work only after the machine has cooled down.

Servicing heated and pressurized hydraulic components may cause plugs, screws and/or oil to fly off or escape suddenly, possibly resulting in personal injury. Hydraulic components may be pressurized even when cooled.

Keep body parts and face away from the front of plugs or screws when removing them.
  - 3.4 Even after air pressure in the hydraulic oil tank is released, when the machine is parking on a slope, the oil pressure in the travel motor and the swing motor circuits are maintained at high pressure as the reaction force of the machine's own weight is constantly applied to the travel motor. Never check and/or service the machine while parked on a slope.

## MAINTENANCE

---

### IMPORTANT:

- **When connecting hydraulic hoses and pipes, take special care to keep seal surfaces free from dirt and to avoid damaging them.**
- **Wash hoses, pipes, and the tank interior with a washing liquid and thoroughly wipe off before reconnecting.**
- **Only use O-rings that are free of damage or defects. Be careful not to damage them during reassembly. Do not allow high pressure hoses to twist when connecting them. The life of twisted hoses will be shortened considerably.**
- **Do not use hydraulic oils other than those listed in the table "Brand names of recommended hydraulic oil".**
- **When adding hydraulic oil, always use the same brand of oil; do not mix brands of oil. When using another manufacturer's hydraulic oil, be sure to change the full amount.**
- **The new machine is filled with Hitachi Genuine Hydraulic Oil 5000 (change interval: every 5000 hours). When adding or changing the hydraulic oil, continue to use Hitachi Genuine Hydraulic Oil 5000.**
- **Never run the engine without oil in the hydraulic oil tank.**



## MAINTENANCE

### Change Hydraulic Oil and Replace Full-Flow Filter Element

Hydraulic breaker operation causes the hydraulic system to become contaminated faster and quickly deteriorates the hydraulic oil.

Failure to adhere to proper maintenance intervals may result in damage to the base machine and the breaker.

In order to extend service life, particularly that of the hydraulic pump, change the hydraulic oil and the full-flow filter element at the specified frequency given below.

Check machine service hours by using the breaker hour meter. (Refer to the Breaker Operation in the OPERATOR'S STATION chapter.)

Changing intervals for the high performance element (micro-glass)

Breaker Operating Availability	0 %	10 %	20 %	30 %	40 %	50 %	60 %	70 %	80 %	90 %	100 %
Full-Flow Filter	1000	670	510	410	340	290	250	230	200	190	170
Hydraulic oil: 2000 hours life time	2000	1590	1320	1130	990	880	790	710	650	600	560
Hydraulic oil: 5000 hours life time	5000	2790	1930	1480	1200	1010	870	760	680	610	560

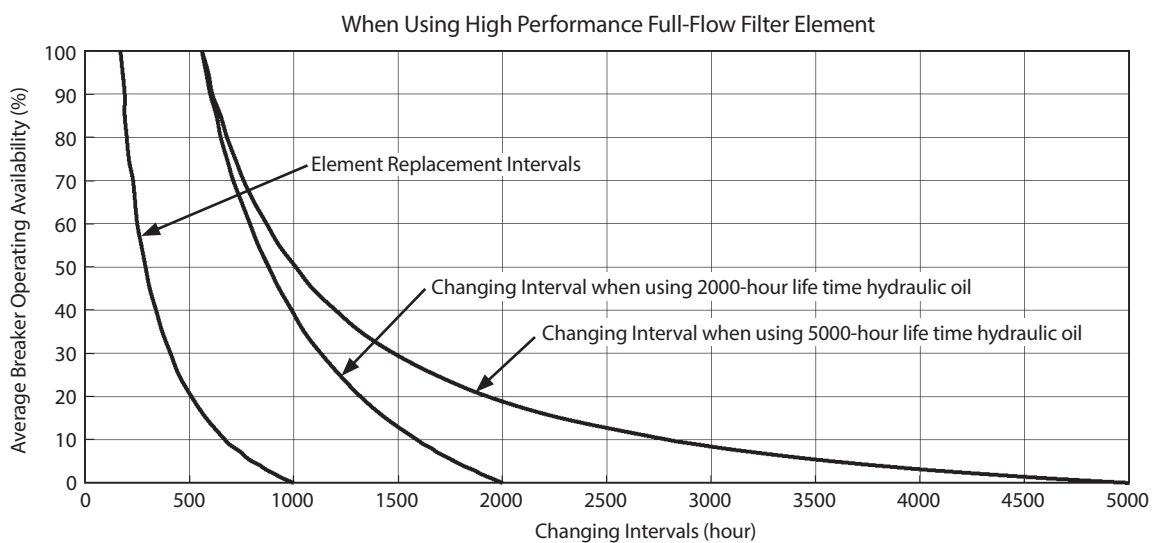

MDAA-07-050

## MAINTENANCE

### 1 Check Hydraulic Oil Level --- daily

**CAUTION:** The hydraulic oil tank is pressurized. Push the pressure release button on the tank cap to release pressure, and carefully remove the cap.



M104-07-021

**IMPORTANT:** Never run the engine without oil in hydraulic oil tank.

1. Park the machine on a firm, level surface.
2. Position the machine with the arm cylinder fully retracted and the bucket cylinder fully extended.
3. Lower the bucket to the ground.
4. Turn the auto-idle switch off.

**IMPORTANT:** The turbocharger may be damaged if the engine is not properly shut down.

5. Run the engine at slow idle speed without load for 5 minutes.
6. Turn the key switch OFF. Remove the key from the key switch.
7. Pull the pilot control shut-off lever to the LOCK position.
8. Open the access door in front of the main pump. Check oil level with level gauge (1) on hydraulic oil tank. Oil must be between marks on gauge (1). If necessary, add oil.

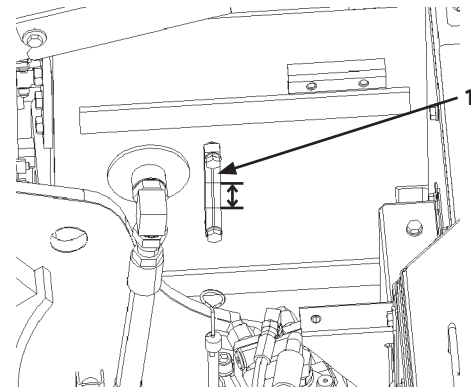

ZX135US-6

MDCN-07-020

To add oil:

9. Push the pressure release button on the air breather to release pressure. Remove the cover.
10. Add oil. Recheck oil level with level gauge (1).
11. Install the cover. Make sure the filter and rod assembly is in correct position.

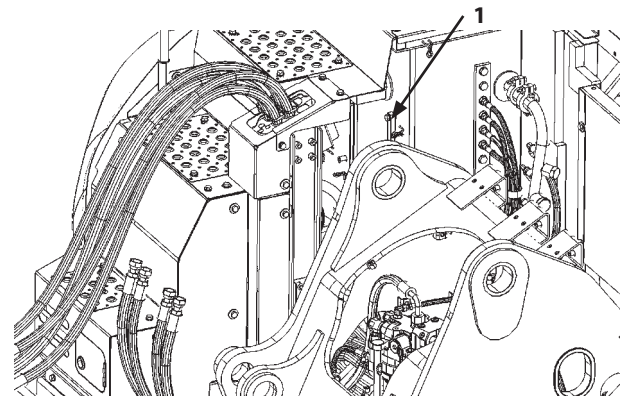

ZX225USLC-6

MDCN-07-021

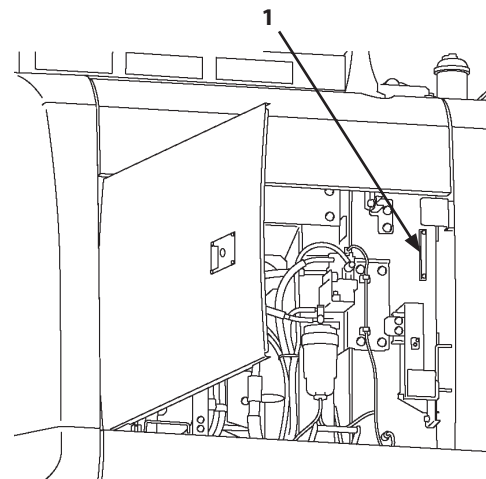

ZX345USLC-6

MDD5-07-009

## MAINTENANCE

### 2 Change Hydraulic Oil --- every 2000 hours or 5000 hours

**CAUTION:**

- Hydraulic oil may be hot just after operation. Wait for oil to cool before starting work.
- The hydraulic oil tank is pressurized. Push pressure release button (1) on the air breather before removing the air breather.

**IMPORTANT:** Hydraulic oil changing intervals differ according to kind of hydraulic oils used. (See Recommended Oil Chart in this group)

1. Park the machine on a firm, level surface with the upperstructure rotated 90° for easier access.
2. Position the machine with the arm cylinder fully retracted and the bucket cylinder fully extended.
3. Lower the bucket to the ground.
4. Turn the auto-idle switch off.

**IMPORTANT:** The turbocharger may be damaged if the engine is not properly shut down.

5. Run the engine at slow idle speed without load for 5 minutes.
6. Stop the engine. Remove the key from the key switch.
7. Pull the pilot control shut-off lever to the LOCK position.
8. Clean the top of the hydraulic oil tank to keep dirt out of the hydraulic system.
9. Push pressure release button (1) on the air breather.
10. Remove cover (2).
11. Remove oil using a suction pump. The hydraulic oil tank capacity, up to specified oil level, is approximately the value shown in column A below.

Model	A
ZX135US-6	105 L
ZX225USLC-6, 345USLC-6	185 L



M104-07-117

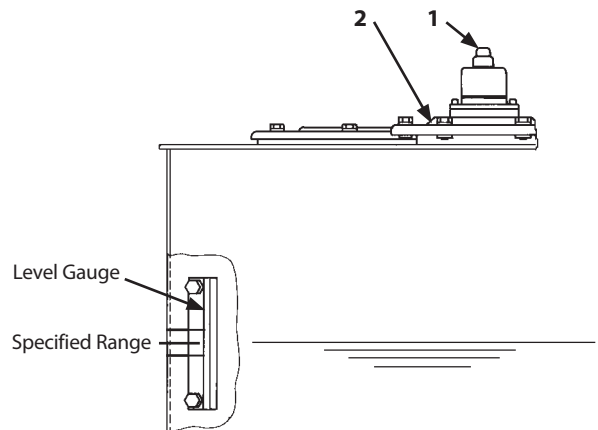

M157-07-016

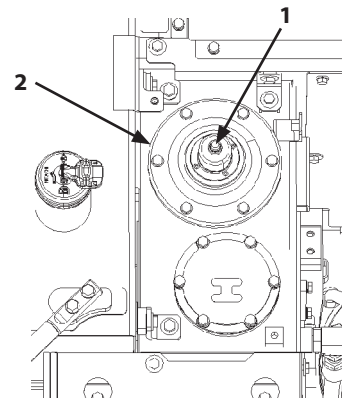

MDCN-07-022

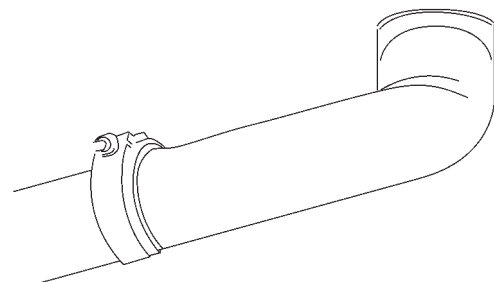

M1U1-07-047

## MAINTENANCE

12. Remove drain plug (3). Allow oil to drain.
13. Clean, install and tighten drain plug (3).
14. Add oil until it is between the marks on the oil level gauge.
15. Install cover (2). Tighten the bolts to 50 N·m (5.0 kgf·m).
16. Be sure to bleed air from the system following the procedures shown on the next page.

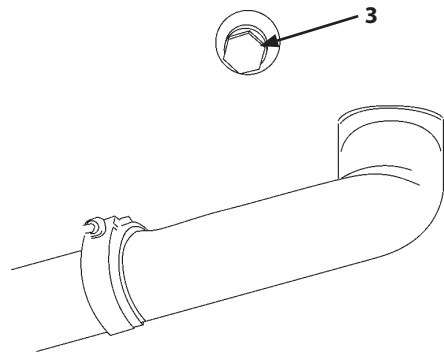

M1U1-07-047

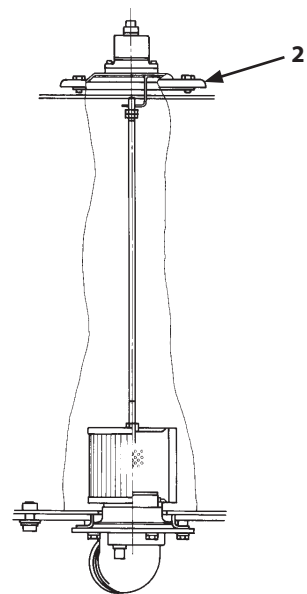

M157-07-062

### Sampling the Engine Oil

 **NOTE:** The line is equipped with a valve (10) for sampling the engine oil. The valve has a cap (9). For instructions on sampling the engine oil, consult your authorized dealer.

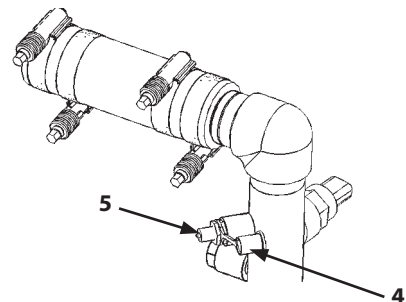

MDAT-07-087

## MAINTENANCE

### Bleed Air from the Hydraulic System

After changing hydraulic oil, bleed air from the hydraulic system by following the procedures below.

**IMPORTANT:** If the hydraulic pump is not filled with oil, it will be damaged when the engine is started. Bleed air from the pump.

- Bleeding Air from Hydraulic Pump
  1. Remove air bleed plug (4) on each pump. Fill the pump with oil through air bleed plug (4) hole.
  2. After hydraulic oil is filled in the pump, provisionally tighten plug (4). Start to run the engine at slow idle speed.
  3. Slightly loosen one of plugs (4). Allow air to bleed from the pump through the clearance until hydraulic oil permeates around plug (4).
  4. After bleeding air, tighten plug (4) to specification.  
Tightening Torque: 95 N·m (9.5 kgf·m)
  5. Repeat Steps 3 and 4 for the remainder of plugs (4).
- Bleeding Air from Hydraulic Circuit
  1. After filling hydraulic oil, start the engine. While moving all cylinders and the swing motor evenly, lightly operate the machine for 10 to 15 minutes.  
  
As the air bleeding device is provided in the pilot circuit, air will be released by conducting the above operation for 5 minutes.
  2. Lower the bucket to the ground to return to the position to check hydraulic oil level.
  3. Stop the engine. Check the oil level. Add oil as needed.

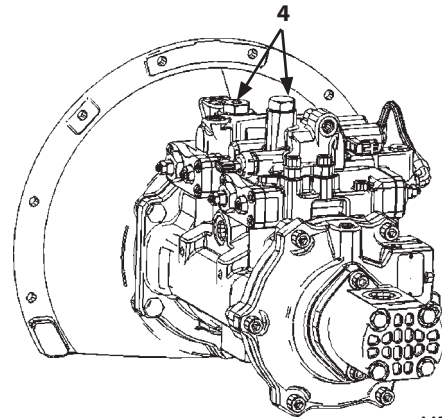

ZX135US-6

MDAA-07-072

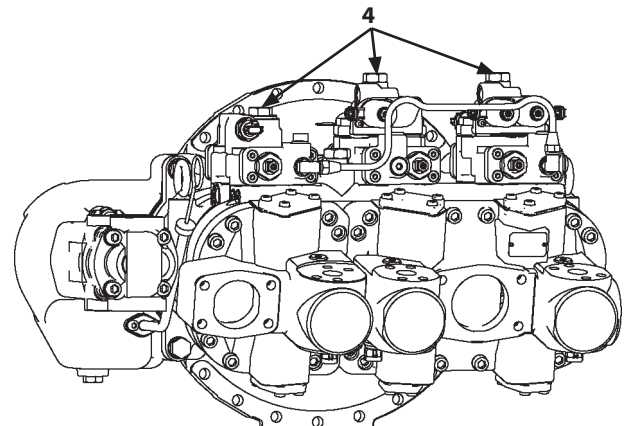

ZX225USLC-6

MDAA-07-001

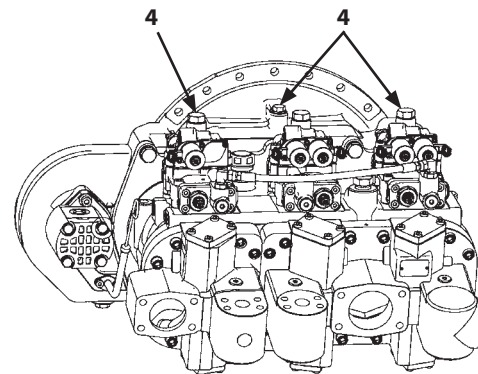

ZX345USLC-6

MDD5-07-051

## MAINTENANCE

### 3 Suction Filter Cleaning ---each time when hydraulic oil is changed

The suction filter is located on the bottom of the hydraulic oil tank.

Clean the suction filter when changing hydraulic oil.

1. After removing hydraulic oil from the hydraulic oil tank, remove cover (1) and rod assembly (2).
2. Clean the inside of the hydraulic oil tank and the suction filter.
3. Before installing the suction filter, check the dimension of rod assembly (2) shown in figure right. Securely insert rod assembly (2) into pipe (3).
4. Before securing cover (1) with bolts, ensure the top edge of the rod assembly (2) is completely inserted into the hole of support (4).
5. Bleed air from the hydraulic system.

(Refer to the descriptions for " **2** Air bleeding procedures")

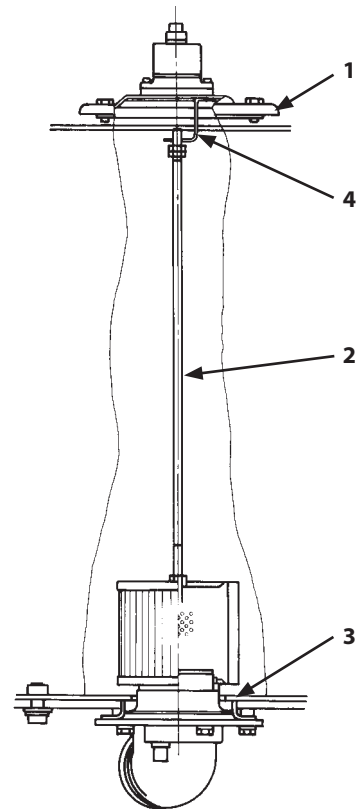

M157-07-062

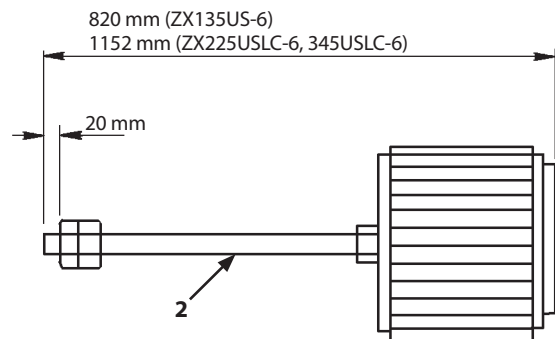

Rod Assembly

M107-07-070

## MAINTENANCE

### 4 Replace Full-Flow Filter --- every 1000 hours

**CAUTION:** Hydraulic oil becomes hot and pressurized during operation. Severe burns may result if skin comes in contact with escaping hydraulic oil just after operation. Wait for the oil to cool before starting any maintenance work.

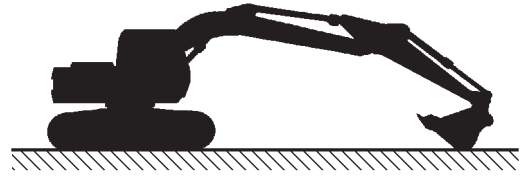

M1CC-07-002

#### Replace

1. Park the machine on solid and level ground with the bucket cylinder fully extended and the arm cylinder fully retracted. Lower the bucket on the ground as shown to the right. Stop the engine.
2. Before replacing element (5), be sure to bleed air pressure from the hydraulic oil tank by pushing release button on the hydraulic oil tank.
3. Loosen bolts (1) (6 used) to remove cover (2) and O-ring (3). When removing cover (2), slowly remove cover (2) while pressing cover (2) downward so that spring (4) does not fly off.
4. Remove spring (4), and element (5).
5. Take extra care not to allow water or dust to enter the filter case.
6. Replace element (5) and O-ring (3) with new one, and install them to the hydraulic oil tank with spring (4). Be careful not to damage element (5) and O-ring (3).
7. Install cover (2) with bolts (1) (6 used).
8. Bleed air from the pump after replacing element (5). (Refer to "Bleed Air from the Hydraulic System".)

If the machine is operated with air mixed in the hydraulic circuit, damage to the pump may result.

**IMPORTANT:** Replace element (5) at the regular interval to keep hydraulic oil clean and to extend the service life of the hydraulic components.

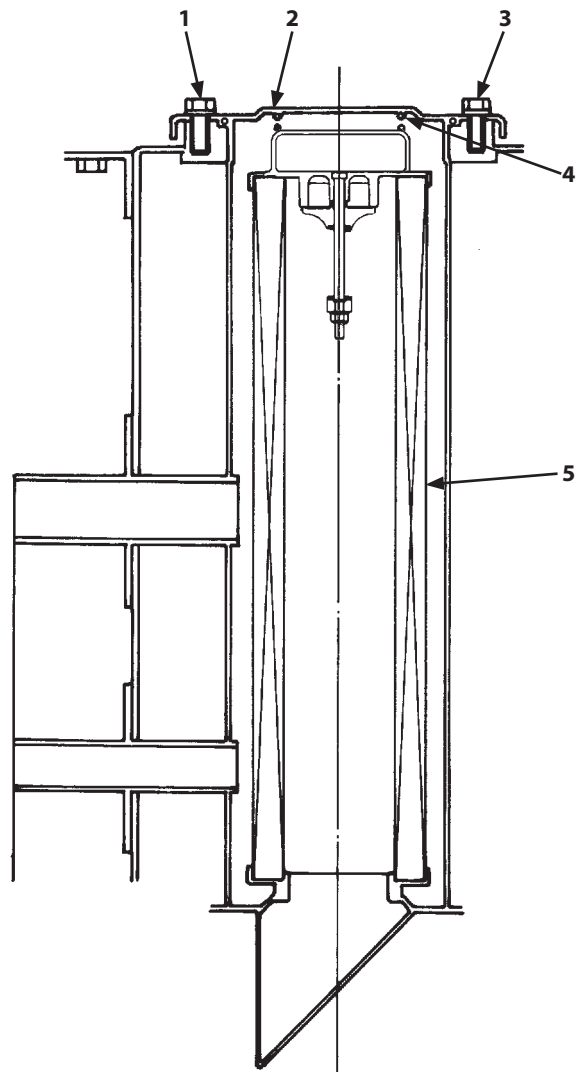

M178-07-069

## MAINTENANCE

### 5 Replace Pilot Oil Filter --- every 1000 hours

**CAUTION:** The hydraulic oil tank is pressurized. Push the pressure release button on the air breather before replacing pilot oil filter.

1. Park the machine on a firm, level surface.
2. Lower the bucket to the ground.
3. Turn the auto-idle switch off.

**IMPORTANT:** The turbocharger may be damaged if the engine is not properly shut down.

4. Run the engine at slow idle speed without load for 5 minutes.
5. Stop the engine. Remove the key from the key switch.
6. Pull the pilot control shut-off lever to the LOCK position.
7. Remove pilot oil filter (2) by turning it counterclockwise with the filter wrench.
8. Clean the filter O-ring contact area on filter head (1).
9. Apply a thin film of clean oil to the gasket of new filter (2).
10. Install new filter (2). Turn filter (2) clockwise by hand until the O-ring touches the contact area. Be sure not to damage the O-ring when installing filter (2).

**IMPORTANT:** Do not re-use pilot oil filter (2).



M104-07-021

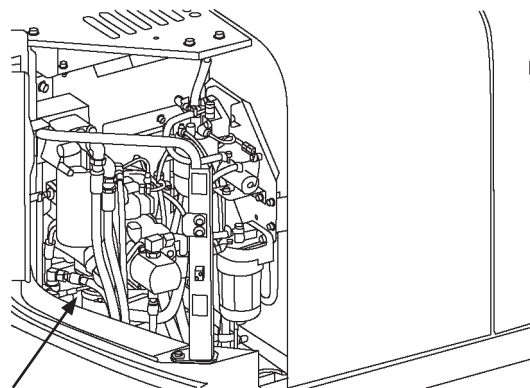

Pilot Filter

ZX135US-6

M1U4-07-038

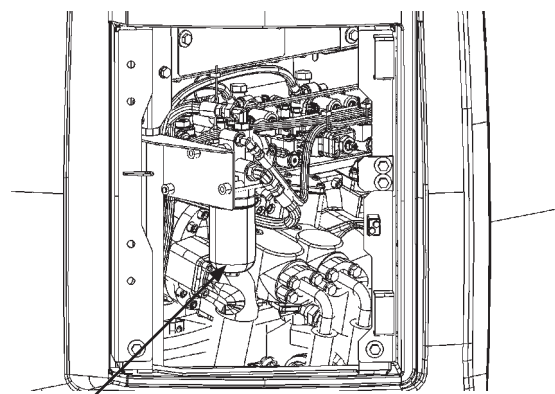

Pilot Filter

ZX225USLC-6

MDCN-07-025

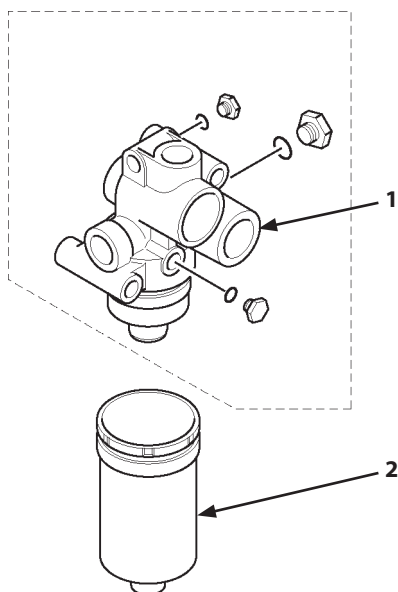

M1U1-07-050

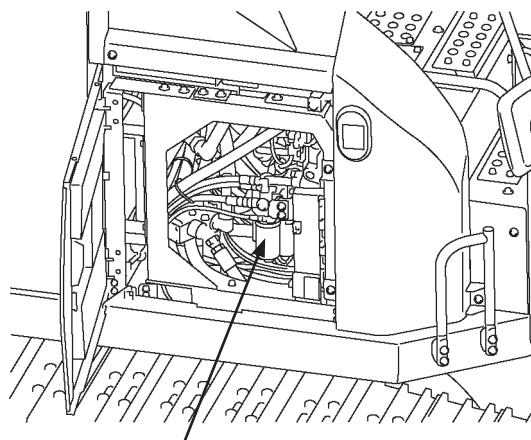

Pilot Filter

ZX345USLC-6

MDD5-07-010



## MAINTENANCE

### 6 Replace Air Breather Element --- every 5000 hours

**CAUTION:** Hydraulic oil becomes hot and pressurized during operation. Severe burns may result if skin comes in contact with escaping hydraulic oil just after operation. Wait for the oil to cool before starting any maintenance work.



M104-07-021

#### Procedures:

1. Park the machine on solid and level ground with the bucket cylinder fully extended and the arm cylinder fully retracted. Lower the bucket on the ground as shown to the right. Stop the engine.
2. Before replacing element (3), be sure to bleed air pressure from the hydraulic oil tank by pushing release button on the hydraulic oil tank.
3. Turn cover (2) clockwise approx. 1/4 turn. Remove cap (1) by turning it counterclockwise.
4. Turn cover (2) counterclockwise and remove it. Remove element (3).
5. Install new element (3). Tighten to install cover (2) until cover (2) comes in contact with element (3). Then, further tighten cover (2) 1/4 turn.
6. Securely tighten cap (1) clockwise by hand. While holding cap (1) by hand so that cap (1) does not turn, securely tighten cover (2) by turning counterclockwise 5 to 10° by hand.
7. Take care never to allow water and/or contaminant to stay between cover (2) and body (4) (air breathing port).
8. Replace element (3) at the regular interval to keep hydraulic oil clean and to extend the service life of the hydraulic components.

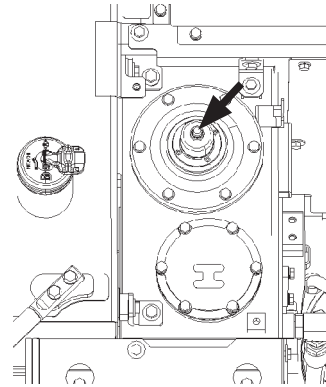

MDCN-07-022

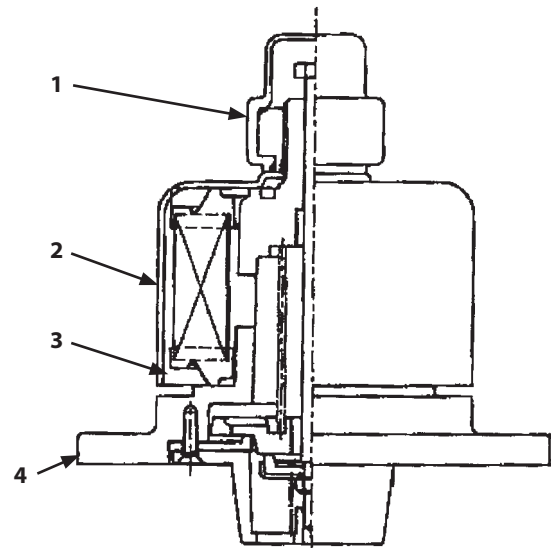

M1G6-07-001

## MAINTENANCE

### 7 Check Hoses and Lines

---daily

--- every 250 hours

#### **!** WARNING:

- Hydraulic oil and lubricant leaks can lead to fire that may result in serious injury. Check for missing or loose clamps, kinked hoses, lines or hoses that rub against each other, damaged oil cooler, and loose oil cooler flange bolts, for leaks.
- Escaping oil under pressure can penetrate the skin causing serious injury. To avoid this hazard, search for oil leaks with a piece of cardboard. Take care to protect hands and body from high-pressure fluids. If an accident occurs, see a doctor familiar with this type of injury immediately.
- Tighten, repair or replace any missing, loose or damaged clamps, hoses and lines.
- Do not bend or strike high-pressure lines.
- Never install bent or damaged hoses or lines.

According to the check points shown below, check hoses and lines for oil leaks and damage.

If any abnormality is found, replace or retighten as instructed in the table.



SA-031



SA-292

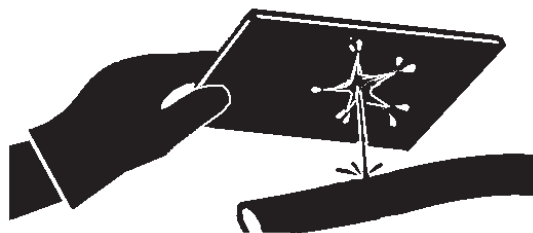

SA-044

#### Hose

Interval (hours)	Check Points	Abnormalities	Remedies
Daily	Hose covers	Leak (1)	Replace
	Hose ends	Leak (2)	Replace
	Fittings	Leak (3)	Retighten or replace hose or O-ring

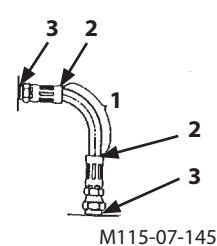
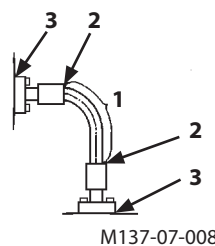

# MAINTENANCE

Interval (hours)	Check Points	Abnormalities	Remedies
Every 250 hours	Hose covers	Damage or leak (4)	Replace
	Hose ends	Damage or leak (5)	Replace
	Hose covers	Exposed reinforcement (6)	Replace
	Hose covers	Crack or blister (7)	Replace
	Hose	Bend (8), Collapse (9)	Replace
	Hose ends and Fittings	Deformation or corrosion (10)	Replace

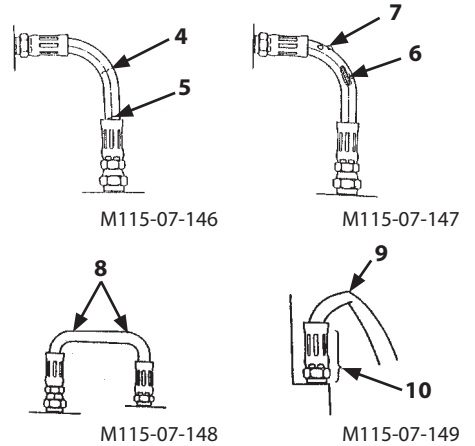

## Lines

Interval (hours)	Check Points	Abnormalities	Remedies
Daily	Contact surfaces of flange joints	Leak (11)	Replace
	Bolts	Loose or leak (11)	Retighten or replace O-ring
	Welded surfaces on flange joints	Leak (12)	Replace
Every 250 hours	Flange joint neck	Crack (13)	Replace
	Welded surfaces on flange joints	Crack (12)	Replace
	Clamps	Missing or deformation Loose bolts	Replace or retighten

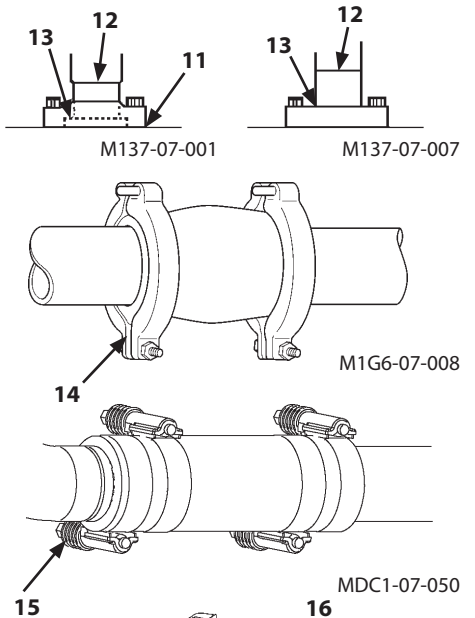

## Hose and Lines

Interval (hours)	Check Points	Abnormalities	Remedies
Daily Check	Flexible master coupling	Leak (14)	Replace or retighten
Every 250 hours	Constant torque clamp	Leak (15)	Replace or retighten

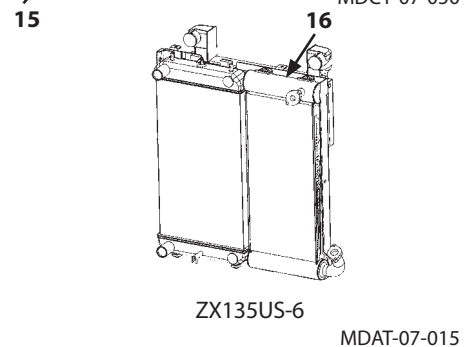

## Oil Cooler

Interval (hours)	Check Points	Abnormalities	Remedies
Every 250 hours	Oil Cooler	Leak (16)	Replace

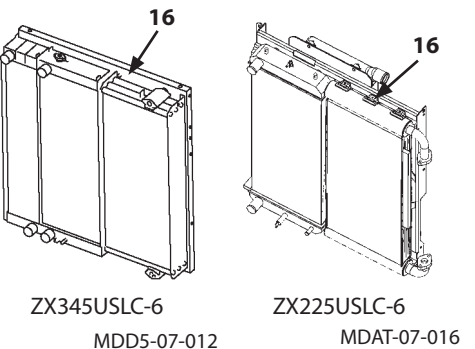

## MAINTENANCE

### Service Recommendations for Hydraulic Fittings

Two hydraulic fitting designs are used on this machine.

- Flat Face O-ring Seal Fitting (ORS Fitting)  
O-ring (1) is used on the sealing surfaces of adapter (2) to prevent oil leakage.

#### Precautions for Use

1. Replace O-ring (1) with a new one when assembling fittings.
2. Check that O-ring (1) is properly fitted in O-ring groove (3). Tighten union (4).

Tightening union (4) with O-ring (1) out of the groove may damage O-ring (1) and cause an oil leak.

3. When assembling fittings, take care not to make a dent on O-ring groove (3) of adaptor (2) and sealing surface (6) on hose (5) or the side of the valve. Failure to do so may result in damage to O-ring (1) leading to an oil leak.
4. If oil leaks from a loose connection of union (4), do not tighten fitting. Open the connection, replace O-ring (1) with new one and check for correct O-ring position before tightening the connection.

#### Tightening Torque:

Tighten fittings to the torque values shown below.

		±10%			
Wrench size (mm)		27	32	36	41, 46
Tightening Torque	N·m	95	140	180	210
	(kgf·m)	(9.5)	(14)	(18)	(21)

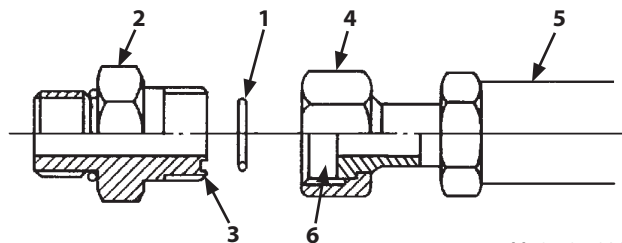

M104-07-033

## MAINTENANCE

- **Metal Face Seal Fittings**

Tight contact between metal flares on adaptor (7) and metal connector (8) of hose (5) prevents pressure oil leakage. This type of fitting is used on smaller diameter joints.

**Precautions for Use**

Connect or disconnect fittings with care not to damage seat surfaces (9 and 10).

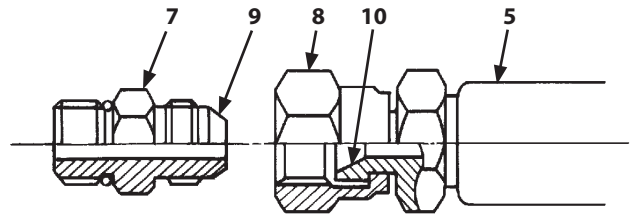

M202-07-051

**Tightening Torque:**

Tighten fittings to the torque values shown below.

Wrench size (mm)		17	19	22	27
Torque	N·m	25	30	40	80
	(kgf·m)	(2.5)	(3.0)	(4.0)	(8.0)

- **Bent Tube**

Tighten bent tube (11) mounted on the control valve to the torque values shown below.

Wrench size (mm)		17, 19
Tightening torque	N·m	35
	(kgf·m)	(3.5)

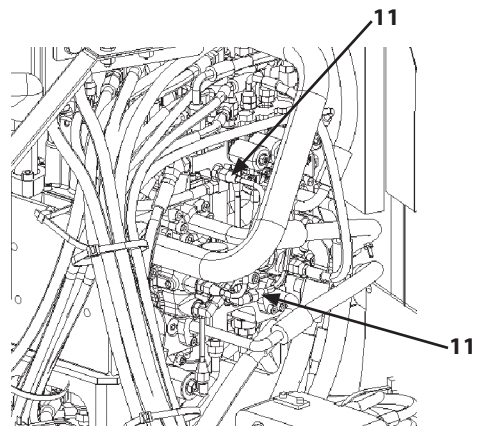

ZX135US-6, 225USLC-6

MDCN-07-029

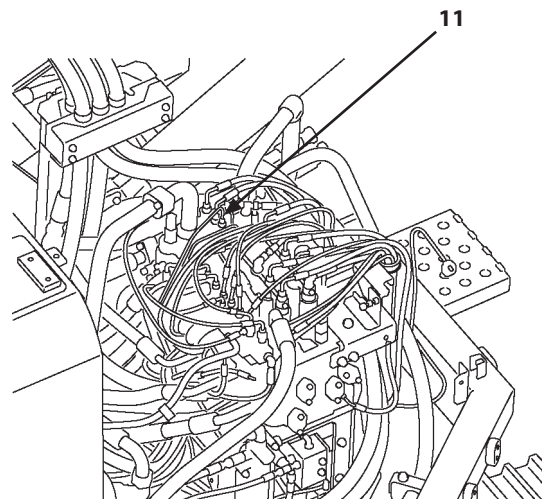

ZX345USLC-6

MDD5-07-013

## MAINTENANCE

---

### E. Fuel System

 **CAUTION: Beware of fire. Fuel is flammable. Keep fuel away from fire hazards.**

#### **Recommended Fuel**

Use only super high quality or high quality DIESEL FUEL (JIS K-2204) (ASTM D-975) (EN-590). Kerosene must NOT be used.

Using bad quality fuel, drainage agent, fuel additives, gasoline, kerosene or alcohol refueled or mixed with specified fuel may deteriorate performance of fuel filters and cause sliding problem at lubricated contacts in the injector. It also affects the engine parts, leading to malfunction. Using fuel other than ultra low-sulfur or low-sulfur diesel fuel has adverse effects on the engine and the aftertreatment device, which may result in malfunction.

# MAINTENANCE

## Refueling

1. Park the machine on a level surface. Lower the bucket to the ground. Check the fuel level with fuel gauge (1).

If the fuel level is low, stop the engine. Refuel by removing cap (2) on the fuel tank.

2. Remove cap (2) of filler port.

[Cap (2) unlock procedures]

- Release the key lock.
- Pull up handle (3) and turn handle (3) counterclockwise for releasing cap (2) lock.
- Remove cap (2).

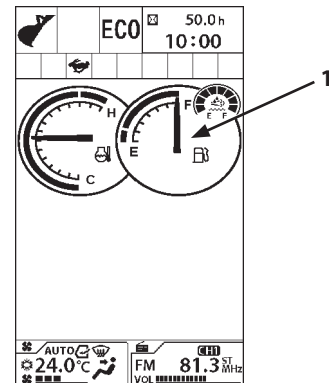

MDC1-01-001

3. To avoid condensation, fill the tank at the end of each day's operation. Tank capacity is as follows.

Model	Tank Capacity
ZX135US-6	220 L
ZX225USLC-6, 345USLC-6	380 L

Do not fill the tank more than specified. Stop filling when a yellow mark on fuel level gauge (4) becomes visible.

Position the oil filler gun so that the gun will not obstruct the floating movement of level gauge (4).

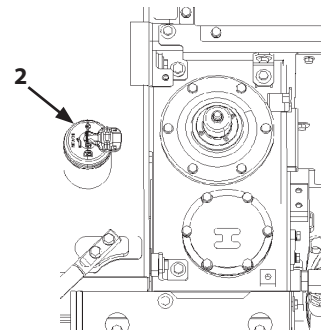

MDCN-07-022

4. Just after fueling, install and lock filler cap (2) to prevent vandalism and loss.

5. Install cap (2) of filler port.

[Cap (2) lock procedures]

- Install cap (2).
- Turn handle (3) clockwise until cap (2) is locked, and push down handle (3).
- Lock the key.

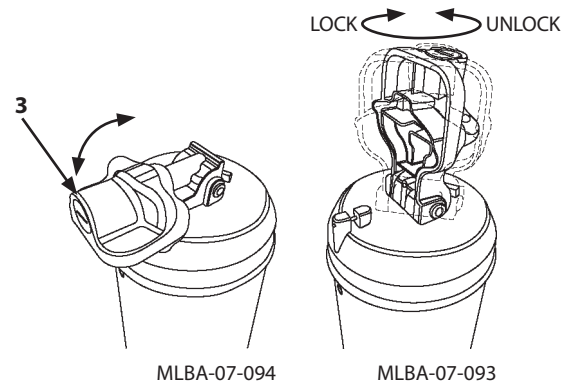

MLBA-07-094

MLBA-07-093

### IMPORTANT:

- **Take care not to allow dirt and/or water to enter the fuel tank.**
- **Wipe off any spilled fuel.**
- **Never forget to remove filler cap (2) when refueling with the automatic fueling device and be sure to stop fueling when the yellow mark on the float of level gauge (4) becomes visible.**

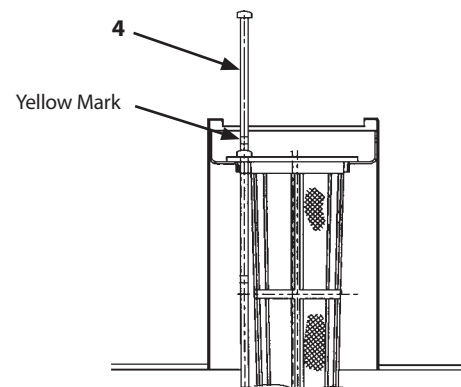

M157-07-060

## MAINTENANCE

### 1 Drain Fuel Tank Sump

--- daily

1. Park the machine on a level surface with the upperstructure rotated 90° for easier access.
2. Lower the bucket to the ground.
3. Turn the auto-idle switch off.



M104-07-117

**IMPORTANT: The turbocharger may be damaged if the engine is not properly shut down.**

4. Run the engine at slow idle speed without load for 5 minutes.
5. Turn the key switch OFF. Remove the key from the key switch.
6. Pull the pilot control shut-off lever to the LOCK position.
7. Place 0.5 liters or larger capacity container under drain hose (2) to collect the drained water.
8. Open drain valve (1) to drain water and/or sediment through drain hose (2).
9. After draining water, securely tighten drain valve (1).

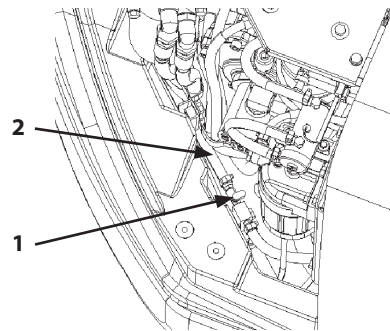

ZX135US-6

MDCN-07-030

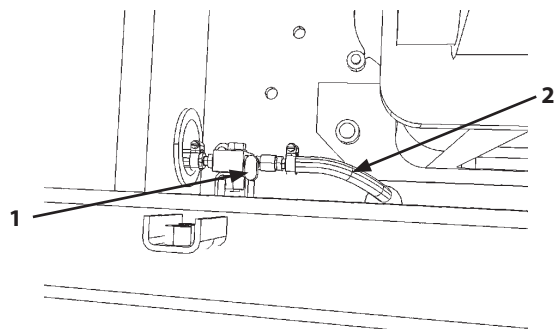

ZX225USLC-6

MDCN-07-031

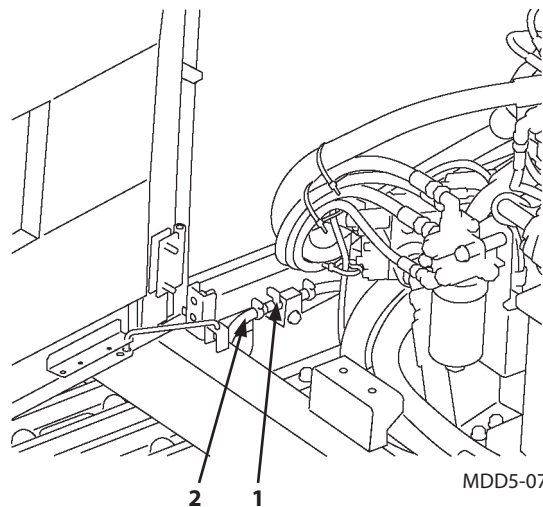

ZX345USLC-6

MDD5-07-014



## MAINTENANCE

### 2 Drain Fuel Pre-Filter --- daily

**IMPORTANT:** Drain fuel pre-filter daily before starting operation. The engine may be damaged if you do not drain fuel pre-filter daily.

The fuel pre-filter has a water separator function. There is a float (8) inside the case which buoys when water accumulates. Check float (8) position daily. Be sure to drain the water accumulated in the pre-filter until float (8) goes to the bottom of pre-filter case.

#### Drain Procedures

1. Place 0.5 liters or larger capacity container under drain hose (6).
2. Rotate drain plug (5) on the bottom of the pre-filter case counterclockwise. Drain the water accumulated in the pre-filter until float (8) goes to the bottom of pre-filter case. If it is difficult to drain, loosen plug (1) on the top of the pre-filter.
3. After draining water, securely tighten drain plug (5) and plug (1).
4. Start the engine. Check drain plug (5) and plug (1) for fuel leaks.

**IMPORTANT:** After draining water mixed in fuel, bleed air from the fuel supply system.

Wrench size: 14 mm

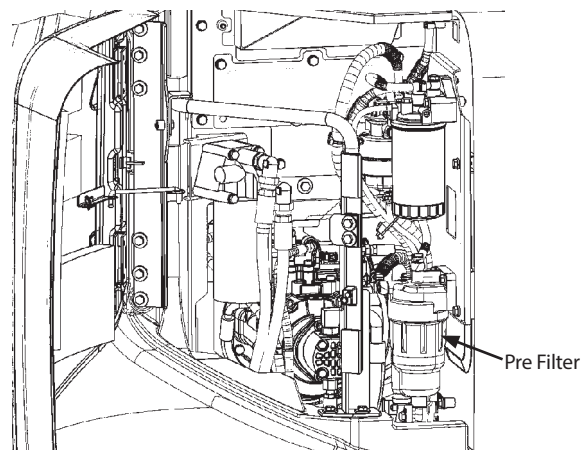

ZX135US-6

MDAT-07-017

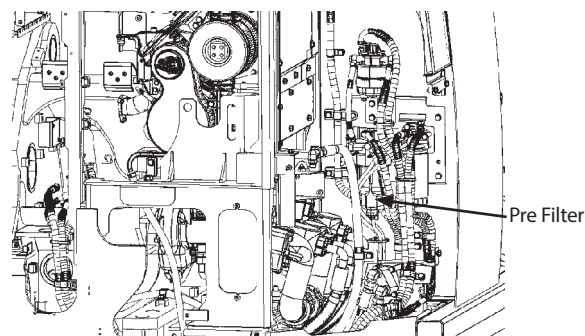

ZX225USLC-6

MDAT-07-018

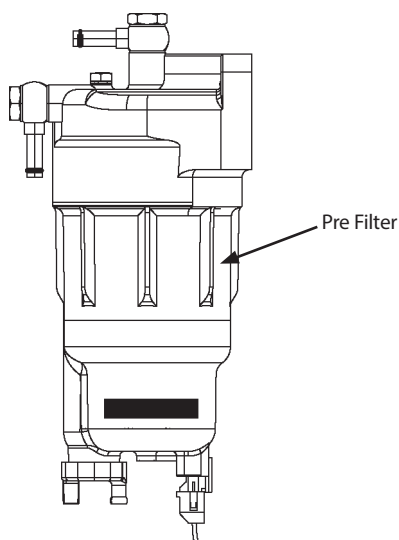

MDC1-07-092

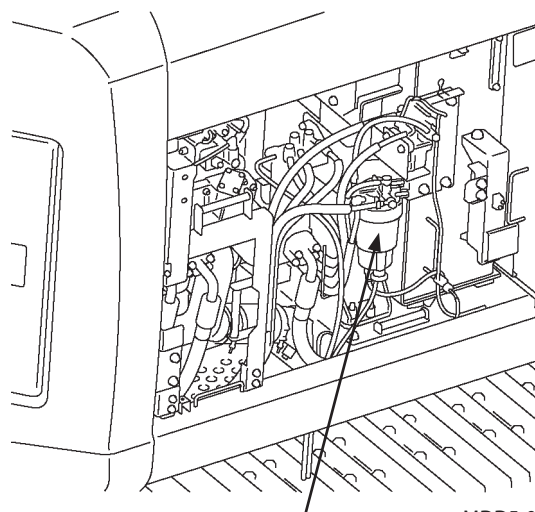

Pre Filter  
ZX345USLC-6

MDD5-07-015

## MAINTENANCE

### Bleed Air from the Fuel System

Air in the fuel system may make the engine hard to start or make it run irregularly.

After draining water and sediment from the fuel filter, replacing the fuel filter, cleaning the fuel solenoid pump strainer or running the fuel tank dry, be sure to bleed the air from the fuel system.

### Main Points to Bleed Air

This machine is equipped with a fuel solenoid pump.

**⚠ CAUTION: Fuel leaks may lead to fires.**

1. Check that fuel cock (1) on the bottom of the fuel tank is opened.
2. Turn the key switch ON and hold it in that position for approx. 3 minutes. Thereby, the fuel solenoid pump operates, starting to bleed air.
3. After the main filter is filled with fuel, hold the key switch in the ON position for 30 seconds.
4. Start the engine. Check the fuel supply system for fuel leaks.

**IMPORTANT: Even if air is not thoroughly bled, do not hold the key switch in the ON position for more than 5 minutes. In case air is not thoroughly bled, first return the key switch to the OFF position. After waiting for more than 30 seconds, turn the key switch ON again. Failure to do so may cause damage to the fuel solenoid pump and/or discharging the batteries.**

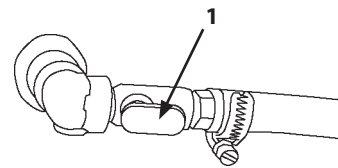

MDAA-07-007

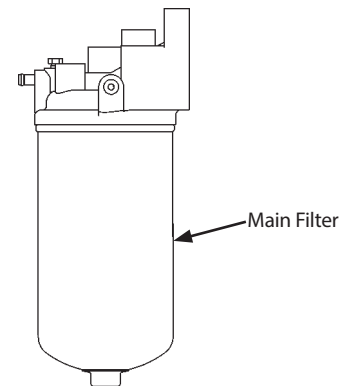

MDC1-07-047

## MAINTENANCE

---

### **If Air Mixed Downstream of Common Rail**

If air becomes mixed into the fuel system due to lack of fuel and the engine is difficult to start, release air by following the procedure below.

1. Following the above mentioned procedures, bleed enough air up to the engine supply pump entrance.
2. Operate starter motor for long cranking within 20 seconds. If engine fails to start, return key switch to OFF. Wait more than about 60 seconds, and then try again.

## MAINTENANCE

- 3** **Replace Fuel Main Filter Element**  
--- every 1000 hours or when fuel filter restriction alarm is lit

### IMPORTANT:

- Be sure to use only genuine Hitachi elements for the fuel main filter element and the pre-filter element. Failure to do so may deteriorate the engine performance and/or shorten the engine service life. Please be noted that all engine failures caused by using other manufacturers' elements are excluded from Hitachi Warranty Policy.
- Take care not to allow dirt and/or water to enter the fuel tank.

### Procedures:

1. Close cock (1) on the bottom of the fuel tank.  
(to next page)

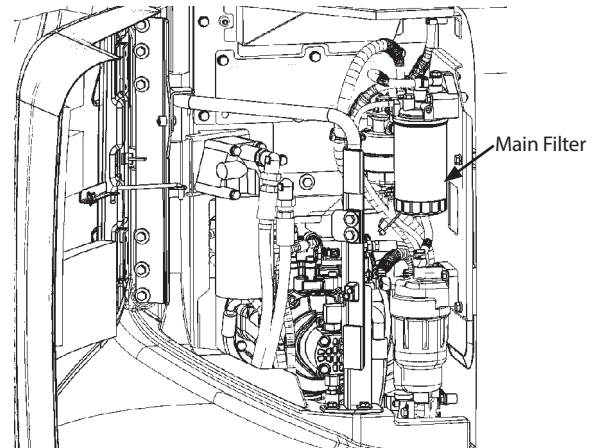

ZX135US-6

MDAT-07-017

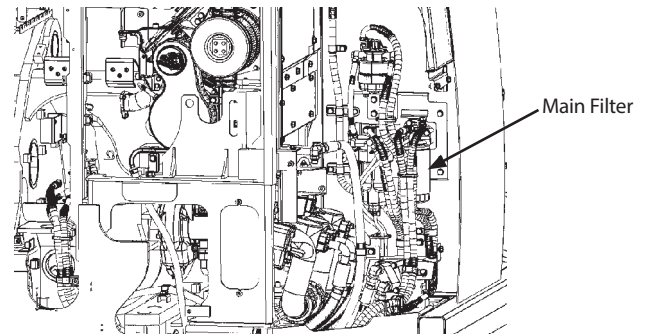

ZX225USLC-6

MDAT-07-018

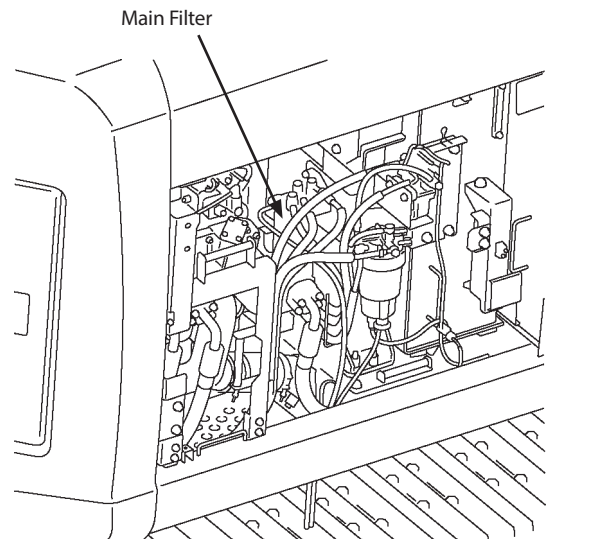

ZX345USLC-6

MDD5-07-015

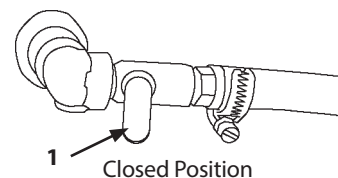

Closed Position

MDC1-07-020

## MAINTENANCE

- Place 1 liter or larger capacity container under the drain hose.
- Rotate the bottom of filter element (2) counterclockwise by using a spanner to remove filter element (2) from head cover (3).
- Apply a thin layer of fuel to the cartridge gasket (O-ring).
- Install new filter element (2) on head cover (3) while rotating filter element (2) clockwise. Tightening torque:  $25 \pm 2 \text{ N}\cdot\text{m}$  ( $2.5 \pm 0.2 \text{ kgf}\cdot\text{m}$ )
- Open cock (1) on the bottom of the fuel tank.
- Bleed Air from the Fuel System

After replacing fuel filter element (2), bleed air from the fuel supply system.

(Refer to "**2** Bleed Air from the Fuel System".)

Wrench size: 24 mm

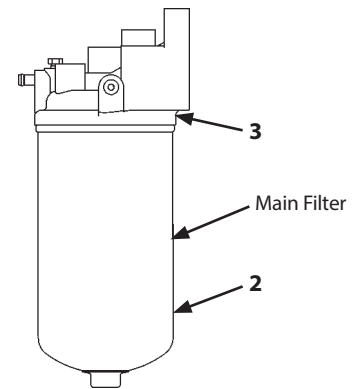

MDC1-07-047

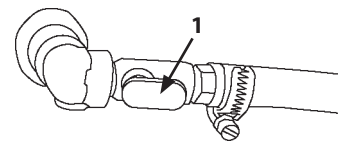

MDAA-07-007

# MAINTENANCE

## 4 Replace Fuel Pre-Filter Element --- every 1000 hours

### IMPORTANT:

- Be sure to use only genuine Hitachi elements. Failure to do so may deteriorate the engine performance and/or shorten the engine service life. Please be noted that all engine failures caused by using other manufacturers' elements are excluded from Hitachi Warranty Policy.
- Take care not to allow dirt and/or water to enter the fuel tank.

### Procedures:

1. Close cock (1) on the bottom of the fuel tank.

(to next page)

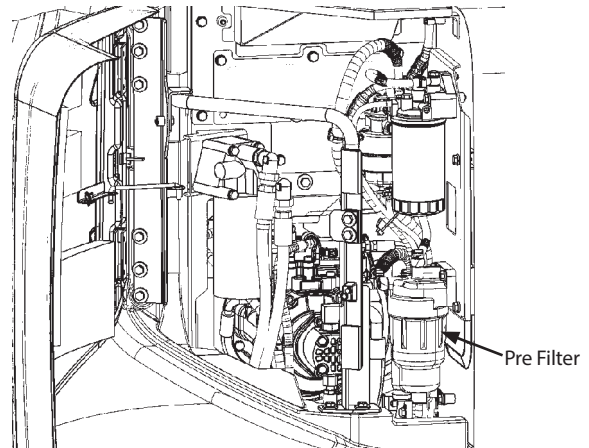

ZX135US-6

MDAT-07-017

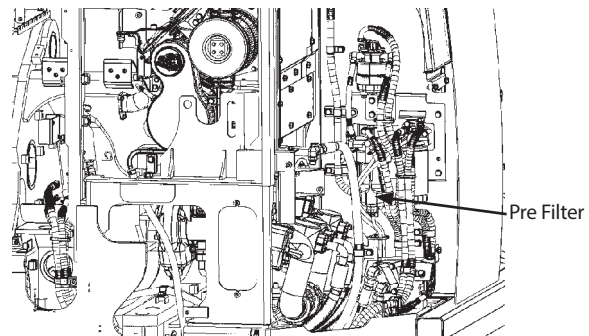

ZX225USLC-6

MDAT-07-018

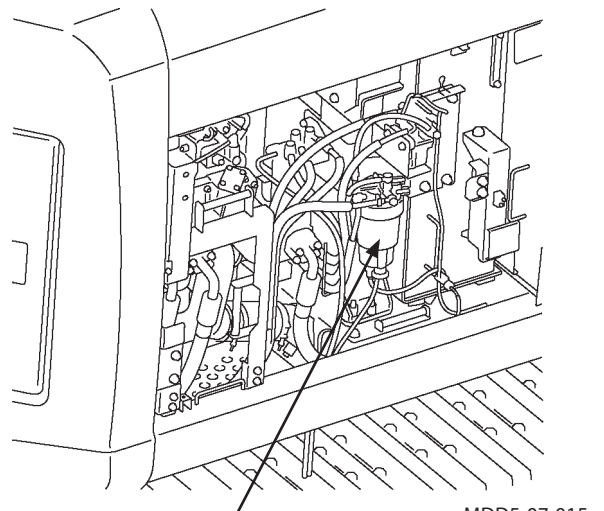

Pre Filter

ZX345USLC-6

MDD5-07-015

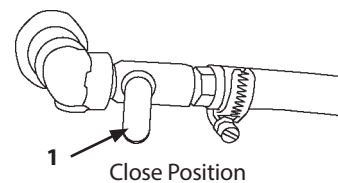

Close Position

MDC1-07-020

## MAINTENANCE

- Place 1 liter or larger capacity container under drain hose (3) to collect the drained water.
  - Loosen air bleed plug (1) and drain plug (2) to drain fuel until fuel does not flow out of the filter.
- After draining fuel, remove drain plug (2) and replace O-ring.
- Remove the harness connected to sensor (7).

**IMPORTANT: The harness connector has a lock (8). Press lock (8) and disconnect the connector. If an attempt is made to disconnect the connector without releasing lock (8), it may damage the connector.**

- Remove transparent filter case (4) using the exclusive tool.
- When transparent filter case (4) is removed, the element and O-ring for transparent filter case (4) is exposed. Remove the element by hand.
- Install a new element. Replace O-ring and tighten transparent filter case (4) to  $30 \pm 2$  N·m ( $3.0 \pm 0.2$  kgf·m) using the exclusive tool.
- Tighten air bleed plug (1) and drain plug (2).
- Reconnect the harness that was disconnected from sensor (7).

**IMPORTANT: Fit the parts together until lock (8) of the harness connector is locked in place.**

- Open cock (5) on the bottom of the fuel tank.
  - Bleed Air from the Fuel System.
- After replacing the fuel filter element, bleed air from the fuel supply system.
- (Refer to "2 Bleed Air from the Fuel System".)
- Wrench size: 14 mm

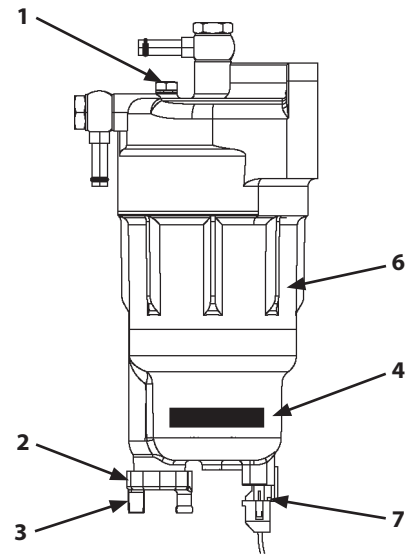

MDC1-07-092

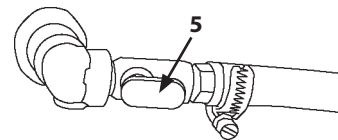

Open Position

MDAA-07-007

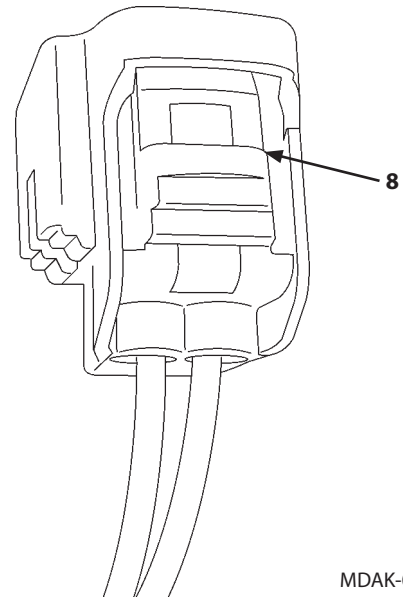

MDAK-07-057

## MAINTENANCE

- 5** Check Fuel Hoses  
 ---daily  
 --- every 250 hours

**⚠ CAUTION:** Fuel leaks can lead to fires that may result in serious injury.

- Escaping combustible fluid can cause fires. Check for kinked hoses, hoses that rub against each other, and any fuel leaks.
- Repair or replace any loose or damaged hoses.
- Never reinstall bent or damaged hoses.

According to the check points shown below, check hoses for oil leaks and damage.  
 If any abnormality is found, replace or retighten as instructed in the table.

Hose

Interval (hours)	Check Points	Abnormalities	Remedies
Daily	Hose ends	Leak (1)	Retighten or replace
	Hose covers	Wear, crack (2)	Replace
Every 250 hours	Hose covers	Crack (3)	Replace
	Hose ends	Crack (4)	Replace
	Hose	Bend (5), Collapse (6)	Replace
	Hose fittings	Corrosion (7)	Replace

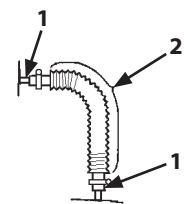

M137-07-003

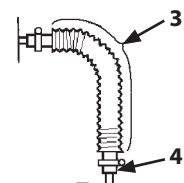

M137-07-004

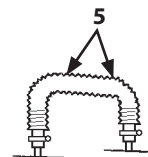

M137-07-005

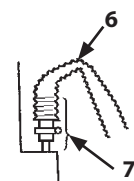

M137-07-006



## MAINTENANCE

### F. Air Cleaner

- 1** Clean and Replace Air Cleaner Element (Outer)  
 Clean --- every 250 hours or when the restriction indicator comes ON  
 Replace --- after cleaning 6 times or after one year

**⚠ CAUTION:** When using compressed air pressure (less than 0.69 MPa (7 kgf/cm<sup>2</sup>)), dust may scatter. Wear goggles or safety glasses, gloves and face shield.

**IMPORTANT:** Clean and replace the air cleaner element by following the procedure below. If the following procedures are not followed, dirt may enter into the system and an engine malfunction may result.

- Clean and replace the air cleaner element when the engine is stopped.
- Do not remove the inner element when cleaning the outer element.
- Replace the inner element when replacing the outer element. Do not reuse elements.
- Use clean and dried compressed air.
- When blowing compressed air, be sure to keep the air nozzle away from the element to avoid the filter paper being broken by the pressure of the air.

#### Clean or replace the outer element.

Stop the engine before servicing outer element (1).

1. Remove clamp (2) of the cover. Remove the cover. Remove any dirt from the case.
2. Remove outer element (1) by holding its edge and slowly shaking it left to right, up and down while twisting it. Do not scatter dirt while removing outer element (1).

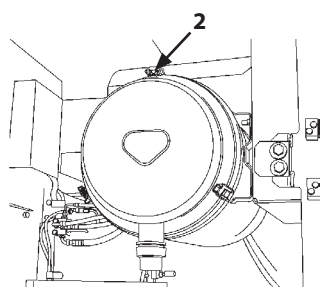

ZX345USLC-6

M1U1-07-027

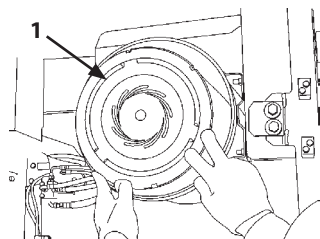

ZX345USLC-6

M1U1-07-028

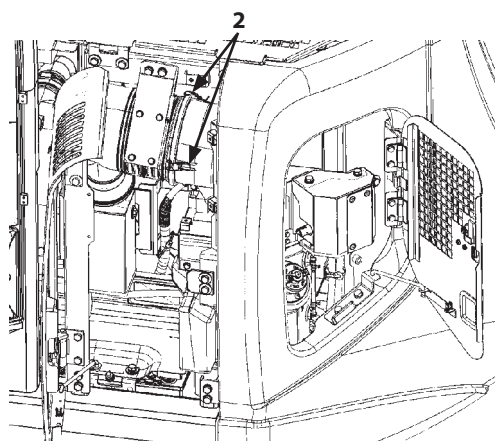

ZX135US-6

MDAT-07-019

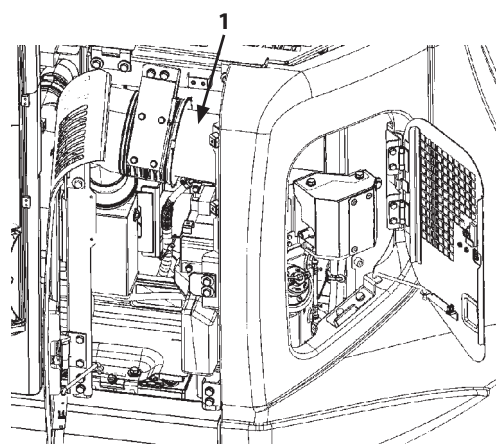

ZX135US-6

MDAT-07-020

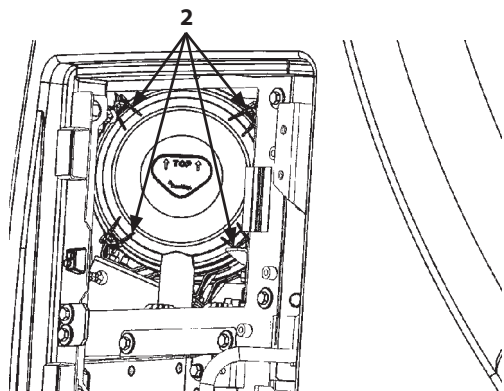

ZX225USLC-6

MDAT-07-021

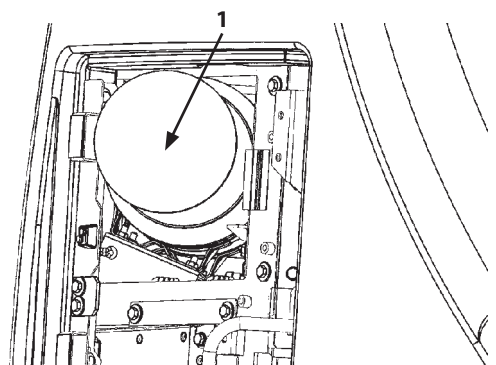

ZX225USLC-6

MDAT-07-022

## MAINTENANCE

3. At this time, do not remove the inner element.

**IMPORTANT: Do not hit or strike outer element (1) against another object to clean the element.**

4. To clean outer element (1), blow compressed air (0.69 MPa (7 kgf/cm<sup>2</sup>) or less) from the inside towards the outside, following the direction of the pleats. Next, blow from the outside inward, and then blow from the inside outward once again. When blowing compressed air, be sure to keep the air nozzle 50 mm or more away from the element.

5. After cleaning is complete, be sure to check outer element (1) for any damage such as holes or wear of filter paper. If any damage is found, replace the element with a new one.

6. Press outer element (1) into the air cleaner body straightly by hand. Ensure that outer element (1) is properly installed by pushing its bottom edge.

7. Install cover and tighten clamps (2).

8. In case the air filter restriction indicator lights soon after cleaning outer element (1) even if it has been cleaned less than 6 times, replace both outer and inner elements with new ones.

**IMPORTANT: Do not install outer element (1) and/or the cover forcibly when installing the clamps. Doing so may result in deformation of clamps (2), element, and/or cover.**

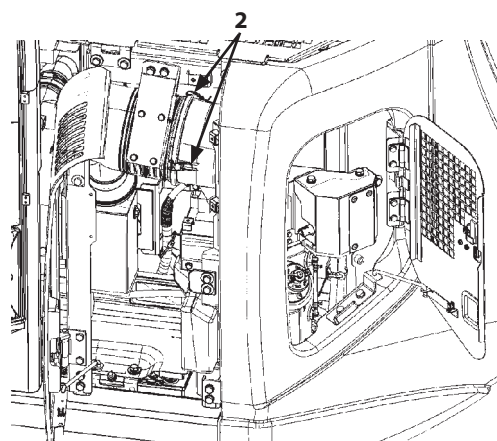

ZX135US-6

MDAT-07-019

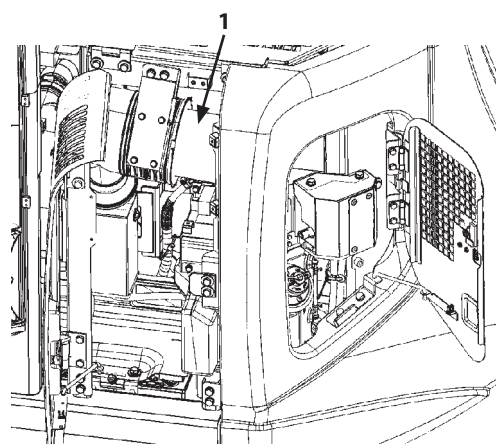

ZX135US-6

MDAT-07-020

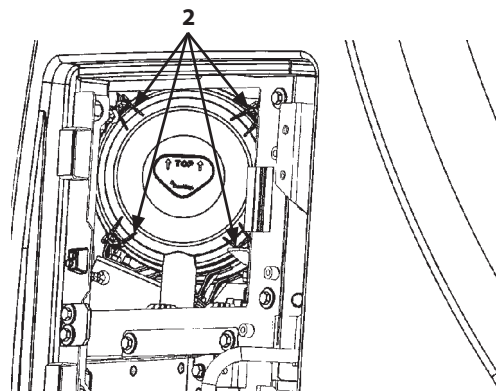

ZX225USLC-6

MDAT-07-021

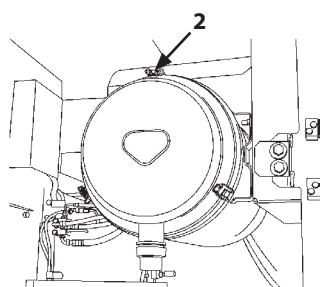

ZX345USLC-6

M1U1-07-027

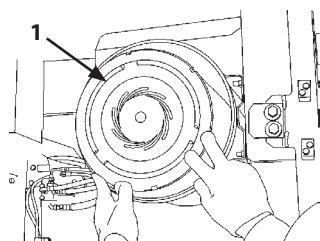

ZX345USLC-6

M1U1-07-028

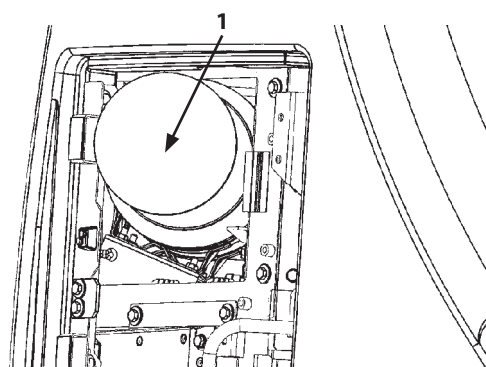

ZX225USLC-6

MDAT-07-022

## MAINTENANCE

---

### **2** Replace Air Cleaner Element (Inner) Replace --- When outer element is replaced

**IMPORTANT:** Do not clean and reuse the inner element.

1. After removing outer element (1), clean inside the air cleaner body (2) with a clean cloth before removing inner element (3).
2. Remove inner element (3). Replace it with new one.

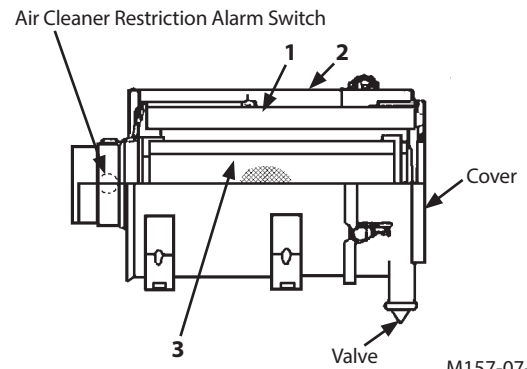

## MAINTENANCE

### G. Cooling System

#### Coolant

**IMPORTANT:** Use soft water as a coolant. Do not use strong acid or alkaline water. Use the coolant with genuine Hitachi Long-Life Coolant (LLC) mixed by 30 to 50 %.

If a coolant mixed with less than 30 % of Hitachi Long-Life Coolant is used, service life of the cooling parts may be shortened due to damage by freezing or corrosion of coolant system parts.

Recommended Products	Alternative Products
Hitachi Genuine Long-Life Coolant	Organic type corrosion inhibitor long life coolant

#### Antifreeze Mixing Ratio

Air Temperature [°C]	Mixing Ratio [%]	ZX135US-6		ZX225USLC-6		ZX345USLC-6	
		Antifreeze [L]	Soft water [L]	Antifreeze [L]	Soft water [L]	Antifreeze [L]	Soft water [L]
-1	30	6.3	14.7	8.4	19.6	12.3	28.7
-15	35	7.4	13.6	9.8	18.2	14.4	26.6
-20	40	8.4	12.6	11.2	16.8	16.4	24.6
-25	45	9.5	11.5	12.6	15.4	18.5	22.6
-30	50	10.5	10.5	14.0	14.0	20.5	20.5

#### Precautions for handling antifreeze

**⚠ CAUTION:** Antifreeze is poisonous.

- Antifreeze is poisonous; if ingested, it can cause serious injury or death. Induce vomiting and get emergency medical attention immediately.
- If antifreeze is accidentally splashed into eyes, flush with water for 10 to 15 minutes and get emergency medical attention.
- When storing antifreeze, be sure to keep it in a clearly marked container with a tight lid. Always keep antifreeze out of the reach of children.
- Pay attention to fire hazards. Antifreeze is specified as a dangerous substance in the fire protection law.
- When disposing of antifreeze, be sure to comply with all local regulations. When storing or disposing of antifreeze, be sure to comply with all local regulations.

# MAINTENANCE

## 1 Check Coolant Level

--- daily

1. Confirm that pilot control shut-off lever (1) is in the LOCK position.
2. Confirm that all control levers are placed in neutral.
3. Insert key switch (2). Turn it to ON position. Press and hold switch (3) with the engine stopped.

Coolant indicator (4) must be displayed in green.

**IMPORTANT:** Do not rely only on the monitor display for checking the machine conditions such as oil level; visually check them yourself as required.

**Always check the machine on a firm, level surface.**

 **NOTE:** If the security function is enabled, a password is required.

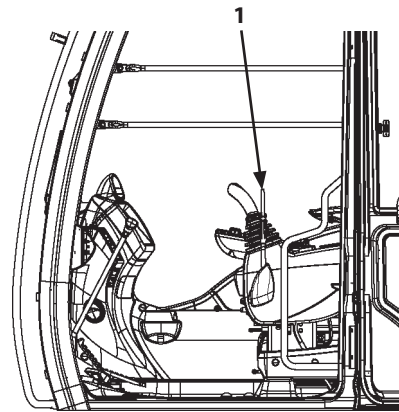

LOCK position

MDAA-01-295

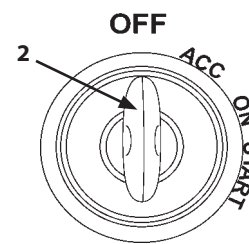

MDC1-01-502

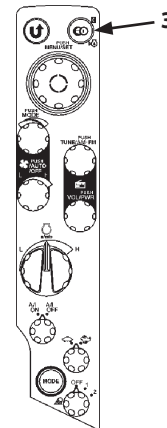

MDCD-01-026

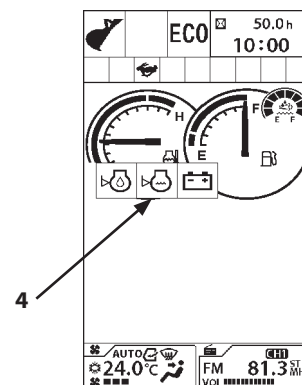

MDC1-01-041

## MAINTENANCE

### --- Visual Inspection

The coolant level must be between the FULL (3) and LOW (4) marks on expansion tank (2).

If the coolant level is below the LOW (4) mark, remove cap (1) from expansion tank (2) and refill coolant.

**⚠ CAUTION:** Do not remove cap (1) until the coolant temperature in the radiator becomes cool. Hot steam may spout out, possibly causing severe burns. After the coolant temperature has lowered, slowly loosen cap (1) to release the air pressure inside before removing cap (1).

If expansion tank (2) is empty, add coolant to the radiator and then to expansion tank (2).

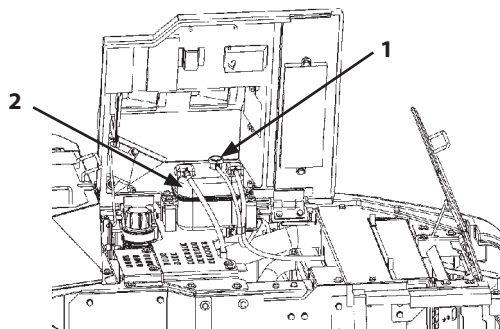

ZX135US-6

MDAT-07-003

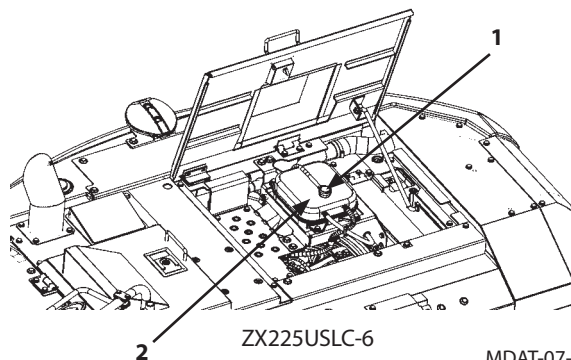

ZX225USLC-6

MDAT-07-007

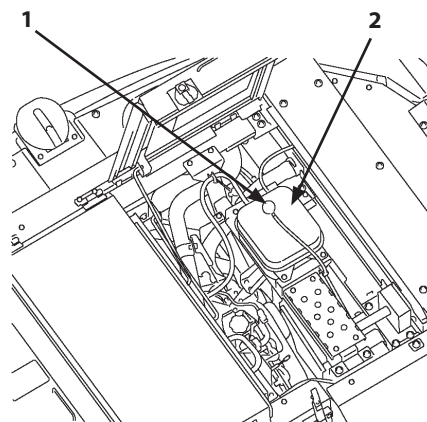

ZX345USLC-6

MDD5-07-006

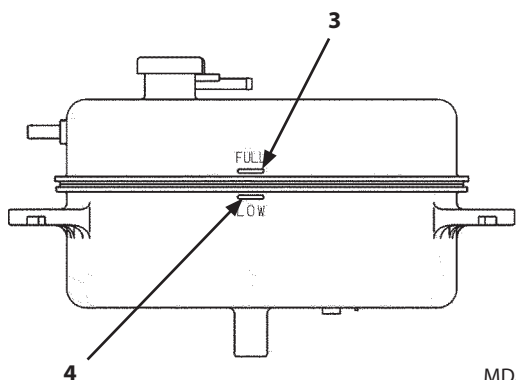

ZX225USLC-6, 345USLC-6

MDAK-07-048

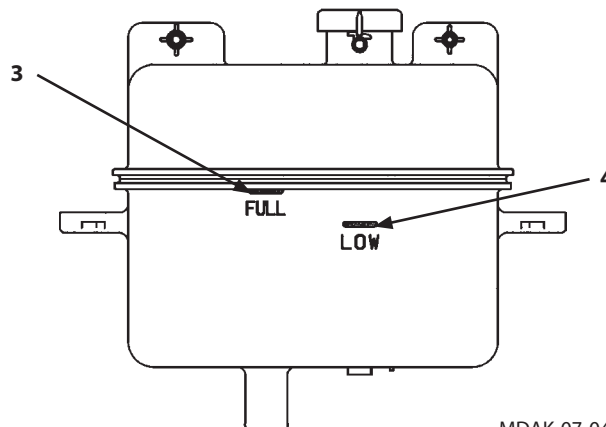

ZX135US-6

MDAK-07-047

## MAINTENANCE

- 2** Check and Adjust Fan Belt Tension  
--- every 250 hours (first time after 50 hours)

### ZX135US-6

**IMPORTANT:** Loose fan belt may result in insufficient battery charging, engine overheating, as well as a rapid, abnormal belt wear. Belts that are too tight can damage both bearings as well as the belts.

#### Inspection

Check fan belt tension by depressing the midpoint between the fan pulley and the alternator pulley by your thumb with a depressing force of approximately 98 N (10 kgf). Deflection must be within the value illustrated in the right. Visually check the belt for wear. Replace if necessary.

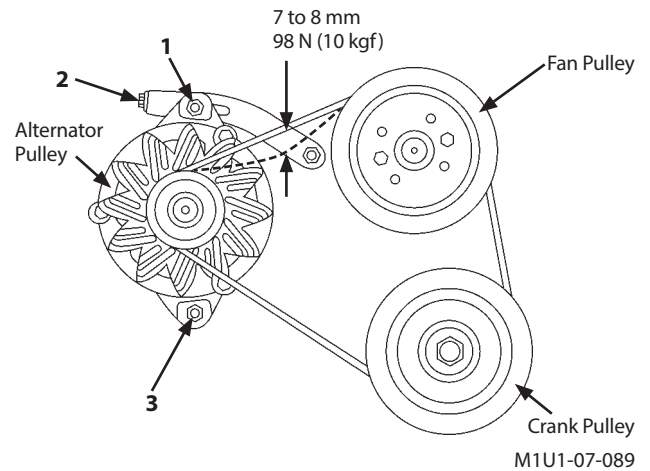

#### Adjust Drive Belt Tension

1. Loosen lock nut (1) and alternator lower mounting bolt (3).
2. Rotate tension adjust bolt (2) to adjust the belt tension.
3. After completing adjustment, tighten lock nut (1) and alternator lower mounting bolt (3) to specifications.

Standard Tightening Torque:

Nut : 25 N·m (2.5 kgf·m)  
Bolt : 52 N·m (5.2 kgf·m)

**IMPORTANT:** When a new belt is installed, be sure to re-adjust the tension after operating the engine for 3 to 5 minutes at slow idle speed to be sure that the new belt is seated correctly.

## MAINTENANCE

### ZX225USLC-6, 345USLC-6

**IMPORTANT:** Loose fan belt may result in insufficient battery charging, engine overheating, as well as premature belt wear. A belt that is too tight can damage both water pump/alternator bearings as well as the belt.

#### Inspect

Check fan belt tension by depressing the midpoint between the fan pulley and the alternator pulley by your thumb with a depressing force of approximately 98 N (10 kgf). Deflection must be within the value illustrated in the right. Visually check the belt for wear. Replace it if necessary.

#### Adjust Drive Belt Tension

1. Loosen lock nut (1) at the top of alternator (3), and lock nut (4) at the bottom of alternator (3).
2. Adjust belt tension by moving alternator (3) forward or backward by using adjustment bolt (2).
3. Securely tighten lock nuts (1) and (4).

**IMPORTANT:** When a new belt is installed, be sure to re-adjust the tension after operating the engine for 3 to 5 minutes at slow idle speed to be sure that the new belt is seated correctly.

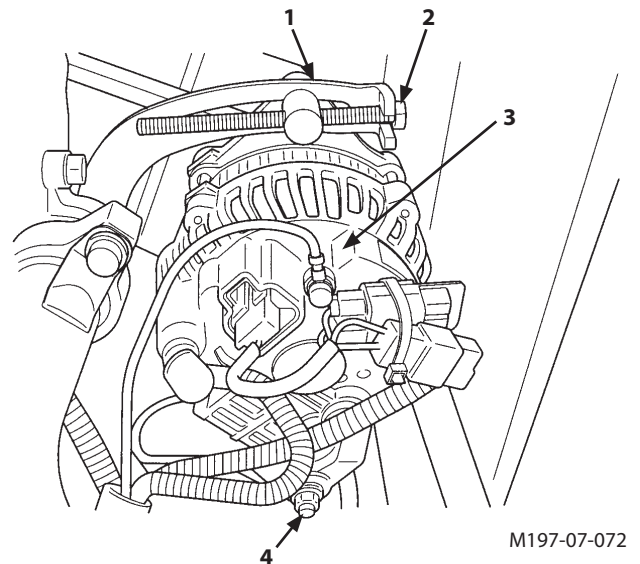
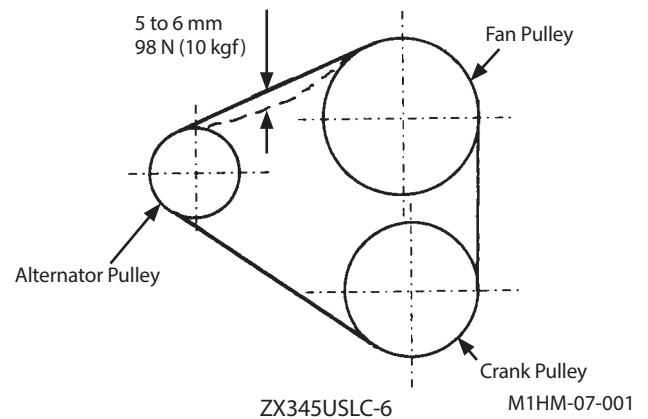
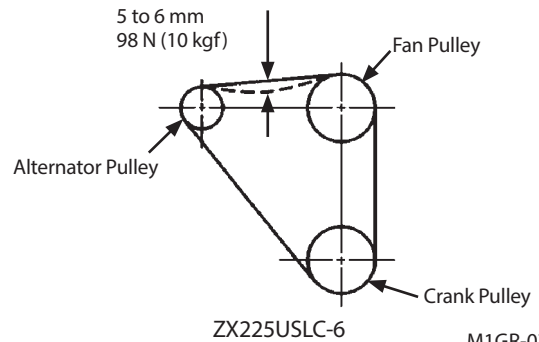



## MAINTENANCE

### 3 Change Coolant --- twice a year (in spring and autumn)

 **NOTE:** When genuine Hitachi Long-Life Coolant is used, change interval is once every two years (in autumn every other year) or every 4000 hours whichever comes first.

 **CAUTION:** Do not loosen the cap on the expansion tank when coolant temperature in the radiator is high. Hot steam may spout out, possibly causing severe burns. Loosen the cap slowly to the stop. Release all pressure before removing the cap.

#### Procedure:

1. Park the machine on a solid level surface. Lower the bucket to the ground. Stop the engine.
2. Remove the under cover. Remove the cap from the expansion tank. Open drain cock (1) on the radiator to allow the coolant to drain completely. Remove impurities such as scale at the same time.
3. Close drain cock (1). Refill soft water containing fewer impurities or tap water and radiator cleaner agent. Close the cap on the expansion tank. Start the engine and run it at a speed slightly higher than slow idle; when the needle of the temperature gauge reaches the green zone, run the engine for about 10 or more minutes.
4. Stop the engine and open radiator drain cock (1). Flush out the cooling system with tap water, until draining water is clear. This helps remove rust and sediment.

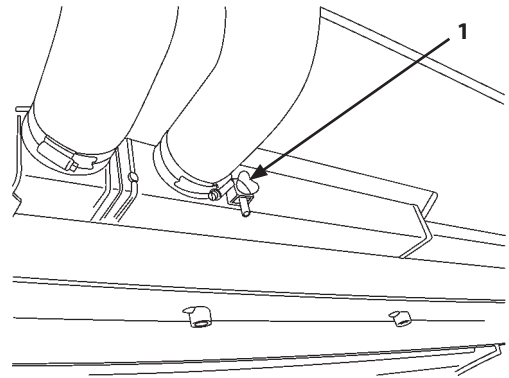

M1U1-07-029

## MAINTENANCE

---

5. Close the radiator drain cock (1). Fill the radiator with tap water and LLC at the specified mixing ratio. When adding coolant, do so slowly to avoid mixing air bubbles in the system.

Fill coolant in the expansion tank until its level reaches the upper limit line.

**IMPORTANT: If coolant is filled above the upper limit line, air in the cooling system may not be bled from the expansion tank. Do not fill coolant above the upper limit line.**

6. Run the engine for several minutes to stabilize the coolant temperature, and then sufficiently bleed air from the cooling system.

Stop the engine. Ensure that coolant level is in between the upper and lower limit line.

Add coolant if necessary. Check the coolant level again (The coolant level should be between the upper and lower limit lines.)

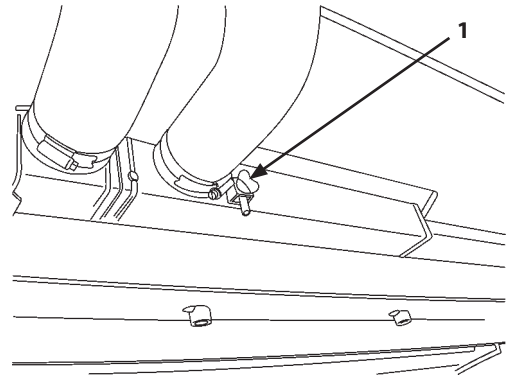

M1U1-07-029

## MAINTENANCE

- 4** Clean Radiator/Oil Cooler/Inter Cooler Core  
 Outside --- every 500 hours  
 Inside --- once a year

**CAUTION:** Use reduced compressed air pressure (Less than 0.2 MPa, 2 kgf/cm<sup>2</sup>) for cleaning purposes. Wear personal protection equipment including eye protection.

**IMPORTANT:** If air with pressure of higher than 0.2 MPa (2 kgf/cm<sup>2</sup>) or tap water with high delivery pressure is used for cleaning, damage to the radiator/oil cooler/inter cooler fins may result.

The radiator, the oil cooler and the inter cooler are arranged in parallel.

If dirt or dust is accumulated on them, cooling system performance decreases. Clean the radiator/oil cooler/inter cooler cores with compressed air pressure (lower than 0.2 MPa (2 kgf/cm<sup>2</sup>)) or tap water. It will prevent a reduction in cooling system performance.

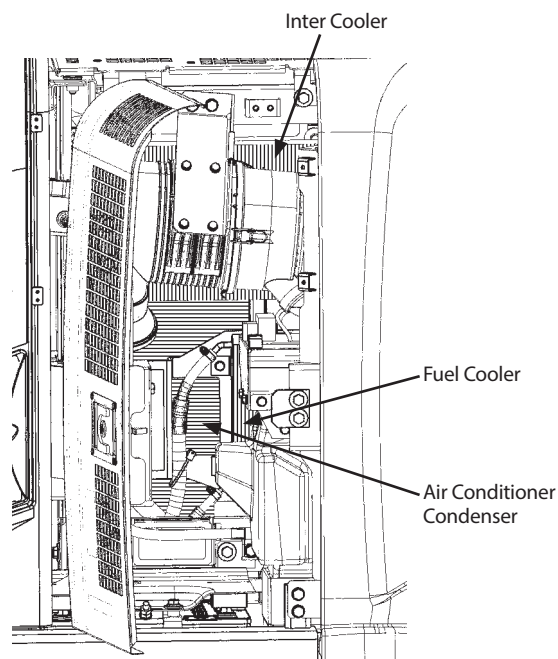

ZX135US-6

MDAT-07-023

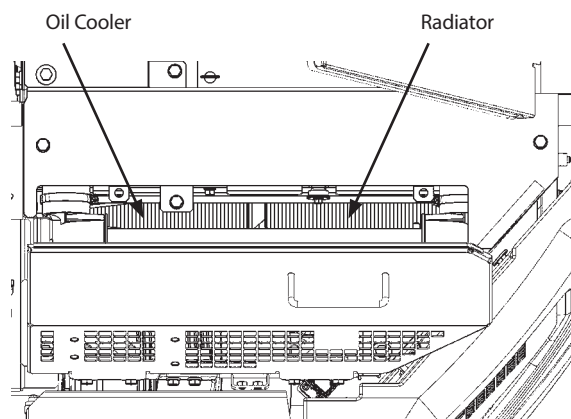

ZX135US-6

MDAT-07-024

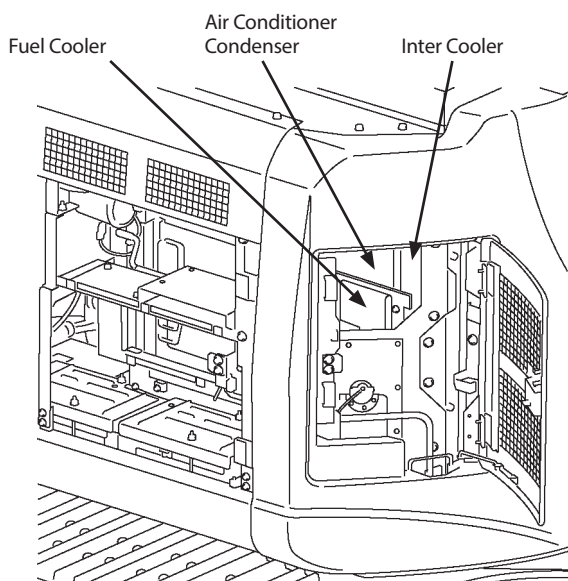

ZX345USLC-6

MDD5-07-016

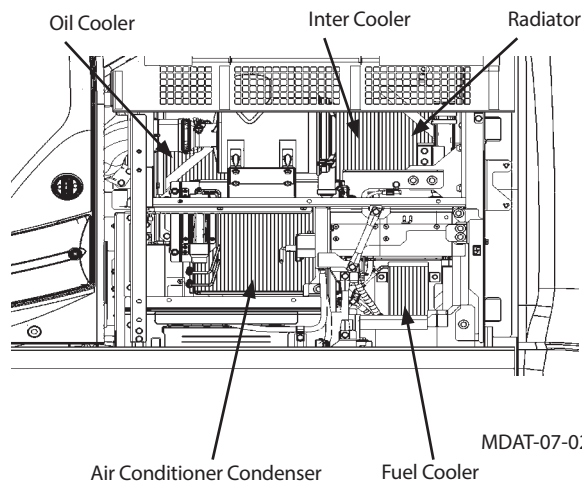

ZX225USLC-6

MDAT-07-025

## MAINTENANCE

### WARNING:

- Entanglement in moving parts can cause serious injury.
- Before servicing, stop the engine and the fan to prevent any accident.
- Never attempt to start the engine when the cover is open.
- In case tools or parts are dropped into the radiator/oil cooler/inter cooler core, remove them before starting the engine.

### Cleaning

1. Loosen bolt (1) to open cover (2) and perform cleaning.

Take care not to break the fin during clean operation.

Close cover (2) and tighten bolt (1) after cleaning.

**IMPORTANT:** When the machine is operated in dusty areas, check the cores periodically and replace if necessary.

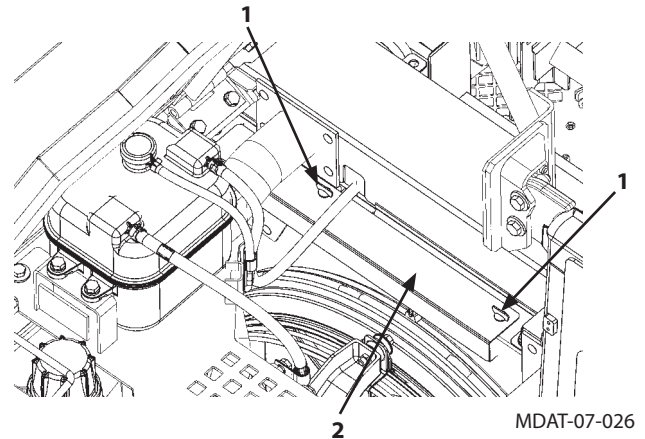

ZX135US-6

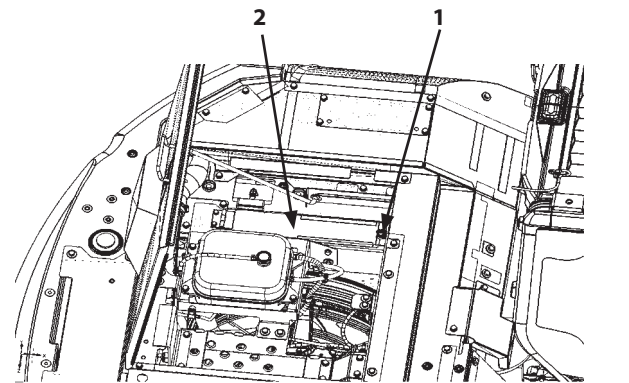

ZX225USLC-6

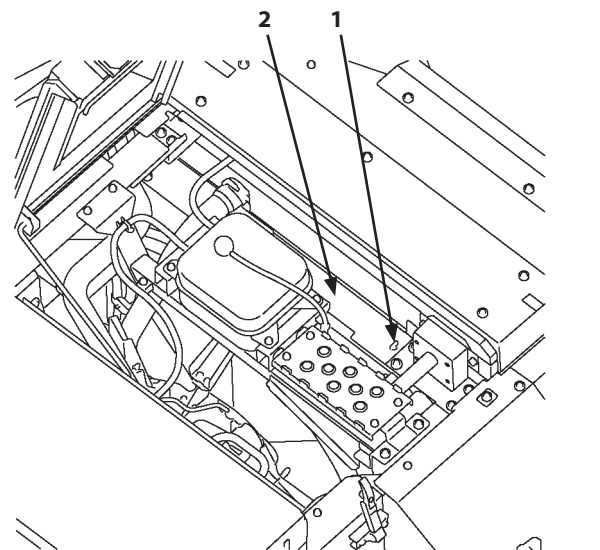

ZX345USLC-6

MDD5-07-017

## MAINTENANCE

### 5 Clean Oil Cooler, Radiator and Inter Cooler Front Screen

--- every 500 hours

**IMPORTANT:** Check the screen daily and clean it if necessary when the machine is operated in dusty areas.

Pull the clip lever on the screen to remove the screen.

Insert the clip into the cover hole and turn over the clip lever to hold the screen.

The screen can not be held properly if the clip nut is too tight or loose. Adjust the tightening torque of the clip nut to hold the screen.

For rough indication of the tightening torque, refer to the below.

Tightening Torque: 0.5 N·m (0.05 kgf·m)

or

A: 2.5 to 3.5 mm

### 6 Clean Air Conditioner Condenser

--- every 500 hours

**IMPORTANT:** Check the screen daily and clean it if necessary when the machine is operated in dusty areas.

### 7 Clean Fuel Oil Cooler

--- every 500 hours

**IMPORTANT:** Check the screen daily and clean it if necessary when the machine is operated in dusty areas.

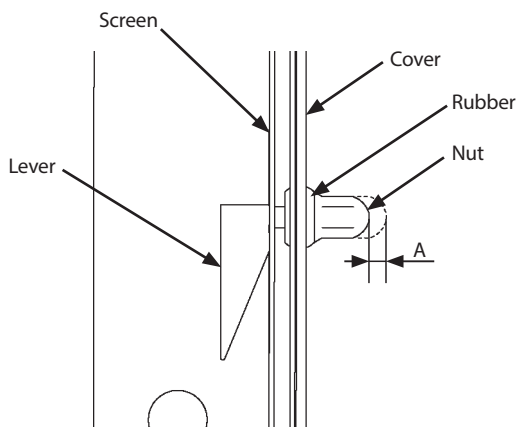

MDAA-07-025

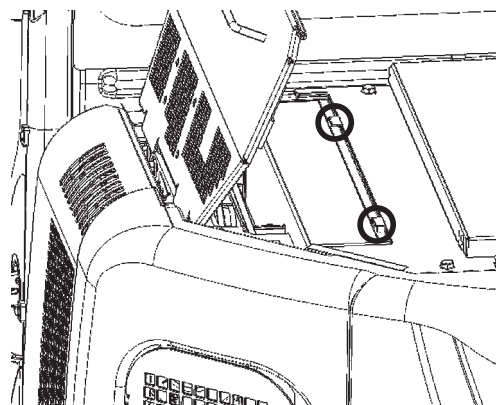

ZX135US-6

MDAT-07-028

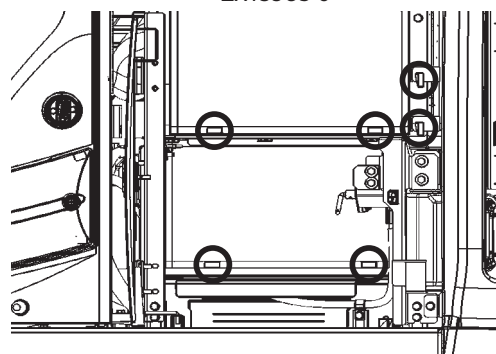

ZX225USLC-6

MDAT-07-029

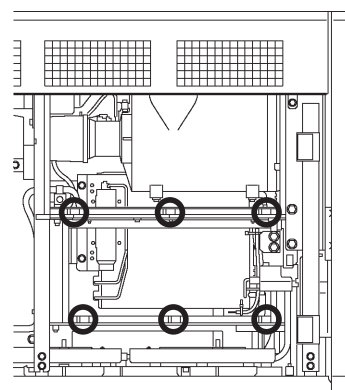

ZX345USLC-6

MDD5-07-018

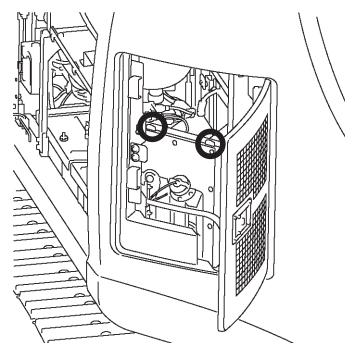

ZX345USLC-6

MDD5-07-019

## MAINTENANCE

- 8** Drain Intercooler (only ZX135US-6)  
--- after operation (If there is a risk of freezing)

### IMPORTANT:

- Condensate may accumulate inside the intercooler under some conditions of use.
- Freezing of condensate may cause damage to the intercooler.  
If there is a risk of freezing, drain after operating the machine.  
The intercooler is very hot directly after operation, so allow it to cool before draining.  
Be careful handling the drained condensate as it may be hot.
- After draining, close drain valve securely.  
Failure to close the drain valve may cause abnormal output of the engine.

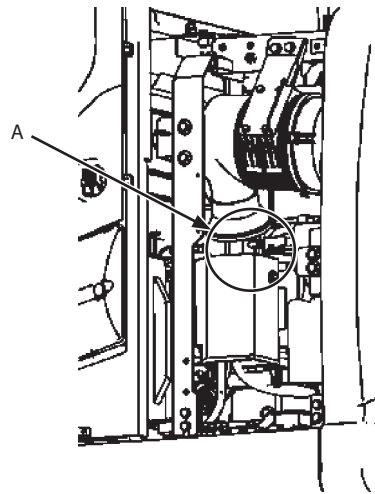

MDAT-07-088

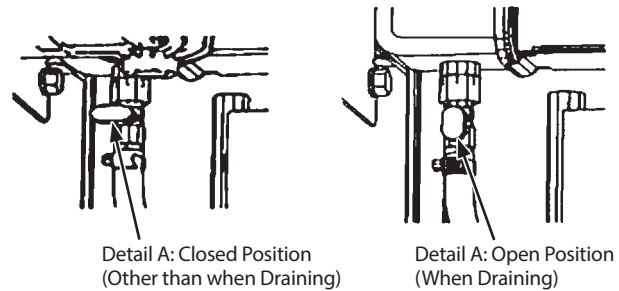

MLAD-07-056

## MAINTENANCE

---

### H. Electrical System

 **WARNING:**

- **Improper radio communication equipment and associated parts, and/or improper installation of radio communication equipment affects the machine's electronic parts, causing involuntary movement of the machine.**
- **Improper installation of electrical equipment may cause machine failure and/or a fire on the machine.**
- **Be sure to consult your authorized dealer when installing radio communication equipment or additional electrical parts, or when replacing electrical parts.**

**IMPORTANT:** Never attempt to disassemble or modify the electrical/electronic components. If replacement or modification of such components is required, contact your authorized dealer.

## MAINTENANCE

### 1 Battery

#### WARNING:

- Battery gas can explode. Keep sparks and flames away from batteries.
- Do not leave cover (1) removed. Do not keep tools, metals or flammable materials around the battery or inside the battery room. If a metal tool is placed across the battery terminal and a vehicle component such as the engine block, sparks may be created, possibly resulting in fire and/or explosion.
- Do not continue to use or charge the battery when electrolyte level is lower than specified. Explosion of the battery may result.
- Charge the batteries in a well ventilated location.
- Sulfuric acid in battery electrolyte is poisonous. It is strong enough to burn skin, eat holes in clothing, and cause blindness if splashed into the eyes. Wearing eye protection and rubber gloves.



SA-032

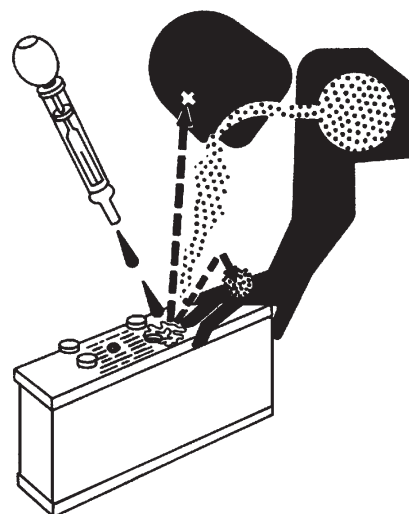

SA-036

#### IMPORTANT:

- If the battery is used with the electrolyte level lower than the specified lower level, the battery may deteriorate quickly.
- Do not refill electrolyte more than the specified upper level. Electrolyte may spill, damaging the painted surfaces and/or corroding other machine parts.

 **NOTE:** In case electrolyte is refilled more than the specified upper level line or beyond the bottom end of the sleeve, remove the excess electrolyte until the electrolyte level is down to the bottom end of the sleeve using a pipette. After neutralizing the removed electrolyte with sodium bicarbonate, flush it with plenty of water, otherwise, consult the battery manufacturer.

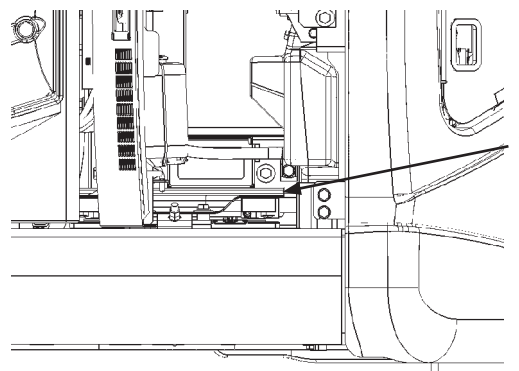

ZX135US-6  
Batteries Location

MDAT-07-030

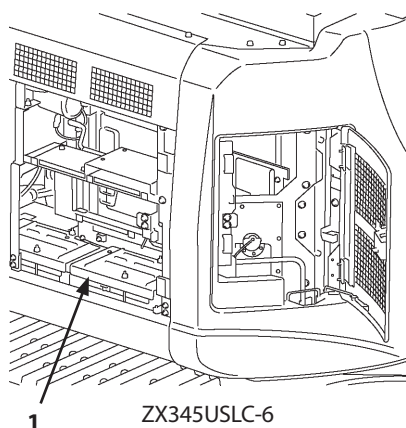

ZX345USLC-6  
Batteries Location

MDD5-07-016

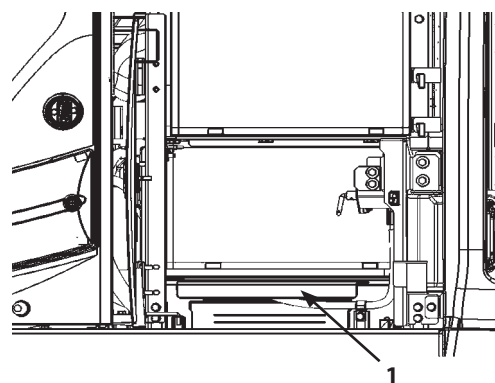

ZX225USLC-6  
Batteries Location

MDAT-07-029



## MAINTENANCE

---

### Precautions for Handling Batteries

- If electrolyte spills on your skin and/or clothes, immediately flush the skin and/or clothes with water and then wash further with soap.  
If splashed in eyes, flush with water for approximately 15 minutes and seek immediate medical attention.
- Avoid using fire hazards such as matches lighters and tobacco near the batteries. Do not allow sparks to fly.
- Check or service the battery only after stopping the engine, turning the key OFF and removing the battery caps.
- Contact with the battery just after operation may cause personal injury.  
Wait for the battery to cool.
- When the battery is recharged, inflammable hydrogen gas is created. Remove the battery from the base machine. Recharge the battery after removing the caps in a well ventilated area.
- When disconnecting the battery terminals, first disconnect the ground line [minus (-)] side terminal. When connecting the battery terminals, connect the ground line [minus (-)] side terminal last. If a piece of metal, such as a tool comes in contact with the battery plus (+) side terminal and the machine frame when both terminals are connected, the electrical system may short-circuit, possibly creating a dangerous situation.
- If a new battery is used along with an old battery, the service life of the new battery may be shortened. Replace two batteries at the same time.
- Loose terminal may allow sparks to fly. Securely tighten the terminals.

## MAINTENANCE

### Electrolyte Level Check --- monthly

Check the electrolyte level at least once a month.

1. Park the machine on level ground and stop the engine.
2. Check the electrolyte level.

#### 2.1 When checking the level from the battery side:

Clean around the level check lines with a wet towel. Do not use a dry towel. Static electricity may be developed, causing the battery gas to explode. Check if the electrolyte level is between U.L (Upper Level) and L.L (Lower Level).

In case the electrolyte level is lower than the middle level between the U.L and L.L, immediately refill with distilled water or commercial battery fluid.

After refilling, securely tighten the filler plug.

Be sure to refill with distilled water before recharging (operating the machine).

#### 2.2 When impossible to check the level from the battery side or no level check mark is indicated on the side:

After removing the filler plug from the top of the battery, check the electrolyte level by viewing through the filler port. It is difficult to judge the accurate electrolyte level in this case. Therefore, when the electrolyte level is flush with the U.L, the level is judged to be proper. Then, referring to the illustrations on the right side, check the level. When the electrolyte level is lower than the bottom end of the sleeve, refill with distilled water or commercial battery fluid up to the bottom end of the sleeve.

After refilling, securely tighten the filler plug.

Be sure to refill with distilled water before recharging (operating the machine).

#### 2.3 When an indicator is available to check the level, follow the checking results.



M146-07-109

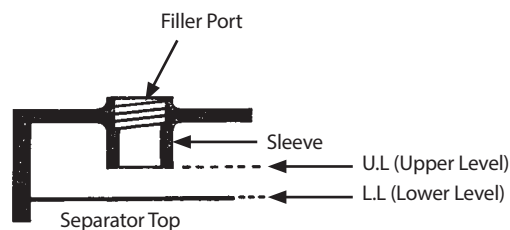

M146-07-110

#### Proper



Since the electrolyte surface touches the bottom end of the sleeve, the electrolyte surface is raised due to surface tension so that the electrode ends are seen curved.

M146-07-111

#### Lower



When the electrolyte surface is lower than the bottom end of the sleeve, the electrode ends are seen straight.

M146-07-112

## MAINTENANCE

---

3. Always keep the area around the battery terminals clean to prevent battery discharge. Check terminals for loose and/or rust.

Check terminals for loose and/or rust. Coat terminals with grease or petroleum jelly to prevent corrosion build up.

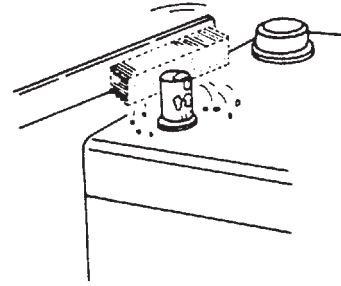

M409-07-072

### Replace Battery

**IMPORTANT: Turn the battery disconnect switch to OFF before replacing the battery.**

This machine is equipped with two 12V batteries. Negative terminal is connected to the ground.

If one battery is damaged on the 24V system, replace the damaged battery with the same type of new battery. If a maintenance free battery is damaged, replace it with new maintenance free battery. Battery charger differs depending on the type of battery. If improper battery is connected, the battery becomes overloaded possibly resulting in malfunction.

## MAINTENANCE

### Check Electrolyte Specific Gravity

--- every one month

**WARNING:** Battery gas can explode. Keep sparks and flames away from batteries. Use a flashlight to check the battery electrolyte level.

Sulfuric acid in battery electrolyte is poisonous. It is strong enough to burn skin, eat holes in clothing, and cause blindness if splashed into the eyes.

Never check the battery charge by placing a metal object across the posts. Use a voltmeter or hydrometer.

Always remove the grounded (-) battery clamp first and replace it last.

Avoid hazard by:

1. Filling batteries in a well-ventilated area.
2. Wearing eye protection and rubber gloves.
3. Avoiding breathing fumes when electrolyte is added.
4. Avoiding spilling or dripping electrolyte.
5. Using proper booster battery starting procedures.

If you spill acid on yourself:

1. Flush your skin with water.
2. Apply baking soda or lime to help neutralize the acid.
3. If splashed in eyes, flush with water for 10 to 15 minutes. Get medical attention immediately.

If acid is swallowed:

1. Do not induce vomiting.
2. Drink large amounts of water or milk.
3. Get medical attention immediately.

**NOTE:** Check the specific gravity of the electrolyte after it is cooled, not immediately after operation.

Check the electrolyte specific gravity in each battery cell.

The lowest limit of the specific gravity for the electrolyte varies depending on electrolyte temperature. The specific gravity should be kept within the range shown below. Charge the battery if the specific gravity is below the limit.

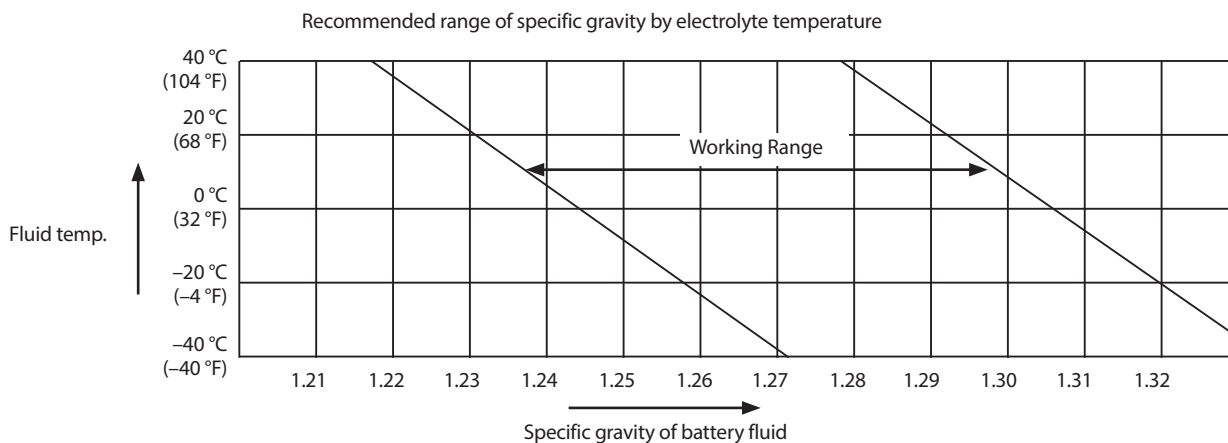

## MAINTENANCE

---

### **2** Replacing Fuses --- as necessary

If any electrical equipment fails to operate, first check the fuses. Fuse box is located behind the operator's seat.

 NOTE:

- *One spare fuse for each respective fuse capacity is provided in the fuse box.*
- *A fuse removing jig is provided in the fuse box.*

# MAINTENANCE

## Fuse Box

### A

10- CONTROLLER 5 A	20- OPT.3 (ALT) 5 A
9- BACKUP 10 A	19- HORN 10 A
8- ECU 30 A	18- IDLE STOP 5 A
7- START 5 A	17- POWER ON 5 A
6- OPT.2 (ALT) 20 A	16- GLOW RELAY 5 A
5- OPT.1 (ALT) 5 A	15- AUX 10 A
4- SOLENOID 20 A	14- MONITOR 5 A
3- HEATER 20 A	13- LIGHTER 10 A
2- WIPER 10 A	12- RADIO 5 A
1- LAMP 20 A	11- FUEL PUMP 5 A

### B

30- -	40- -
29- -	39- -
28- SENSOR_UNIT 10 A	38- -
27- AUX.3 5 A	37- -
26- QUICK HITCH 5 A	36- -
25- IMMOBI 5 A	35- DCU 20 A
24- 12VUNIT 10 A	34- AUX.2 10 A
23- CAB LAMP REAR 10 A	33- WARNING LAMP 10 A
22- CAB LAMP FRONT 10 A	32- CAB LAMP FRONT +2 10 A
21- SEAT HEATER 10 A	31- SEAT COMPR. 10 A

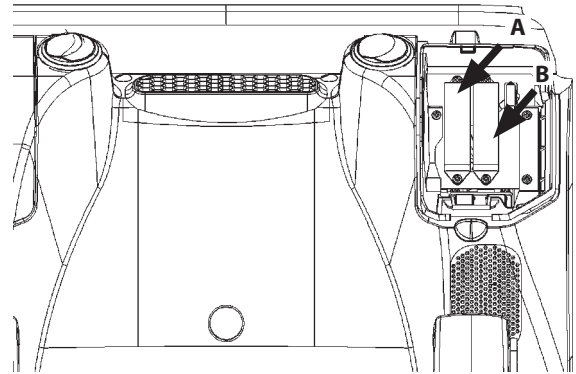

MDCN-01-010

A

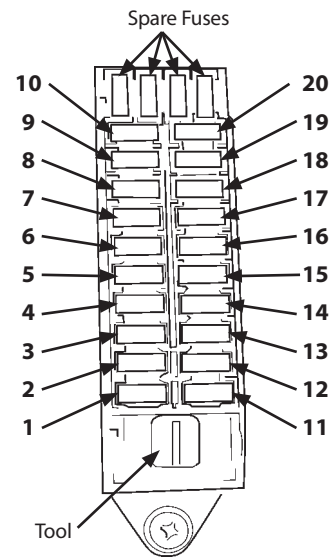

M1GR-01-003

B

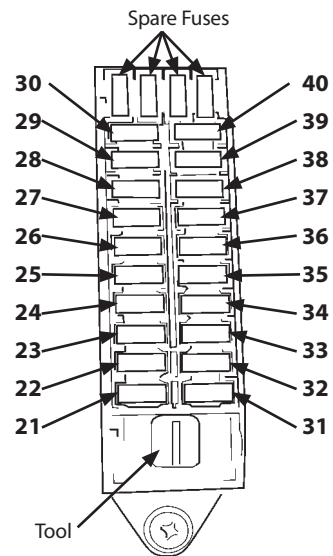

M1GR-01-003

## MAINTENANCE

- Fusible Link (Main Fuse)

In case the starter will not rotate even if the key switch is turned to the START position, fusible link may be the cause of the trouble. Remove the cover next to the battery to check the fusible link. Replace it if blown.

21- + Side (Red)  
45 A

22- - Side (Black)  
65 A

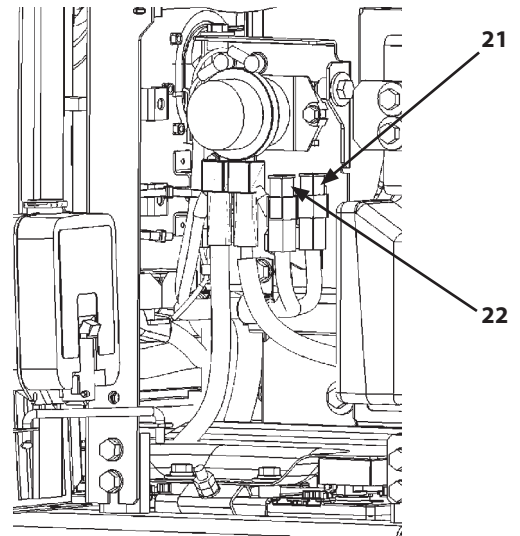

ZX135US-6

MDAT-07-031

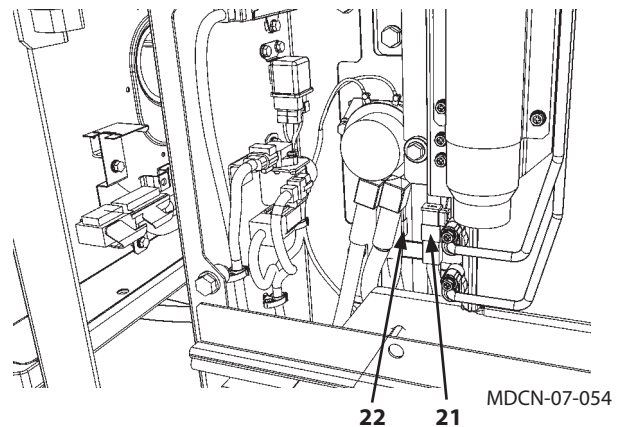

ZX225USLC-6

MDCN-07-054

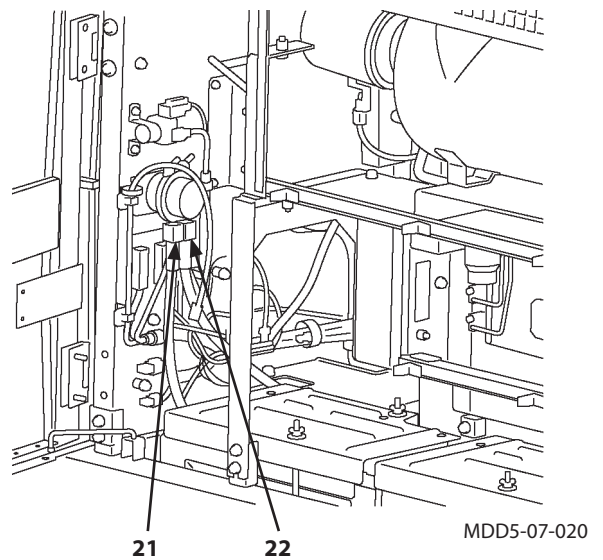

ZX345USLC-6

MDD5-07-020

# MAINTENANCE

## I. Miscellaneous

### 1 Check and Replace Bucket Teeth --- daily

Check bucket teeth (1) for wear and looseness. Replace teeth (1) if tooth wear exceeds the designated service limit shown below.

	A mm	
Model	New	Limit of Use
ZX135US-6	166	85
ZX225USLC-6	200	95
ZX345USLC-6	230	110

#### Replace

#### ⚠ CAUTION:

- Guard against injury from flying pieces of metal.
- Wear goggles or safety glasses, and safety equipment appropriate to the job.

1. Use hammer (2) and drift (3) to drive out lock pin (5). Take care not to damage lock rubber (4).
2. Check lock pin (5) and lock rubber (4). Short lock pins (5) and damaged lock rubber (4) must be replaced with new ones.

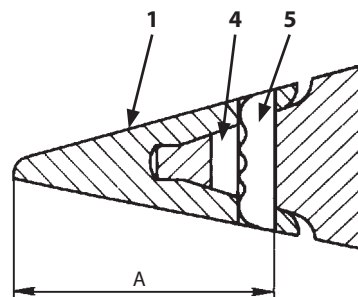

M104-07-056

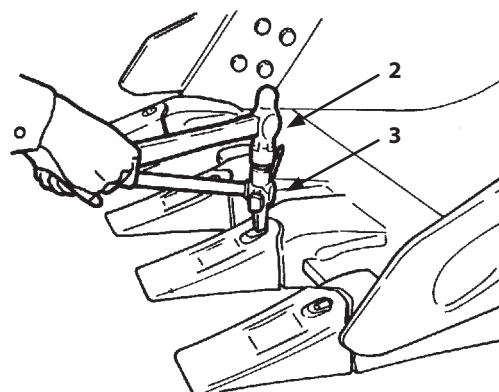

M104-07-116

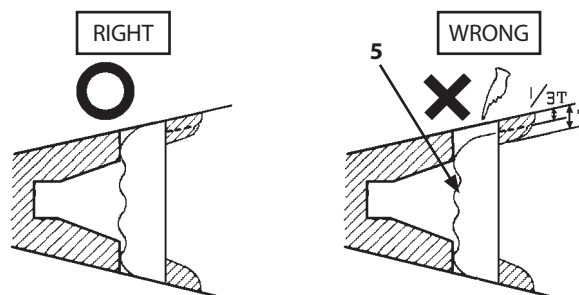

Flush one end of the locking pin to evaluate. In this instance, the locking pin is too short.

M104-07-118

M104-07-058

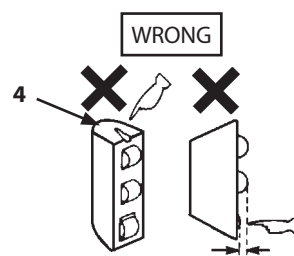

Crack on the rubber. The steel ball may come out.

The steel ball dents when pushing the ball.

M104-07-059



## MAINTENANCE

- Clean shank (6) surface.
- Install lock rubber (4) into shank (6) hole as shown.

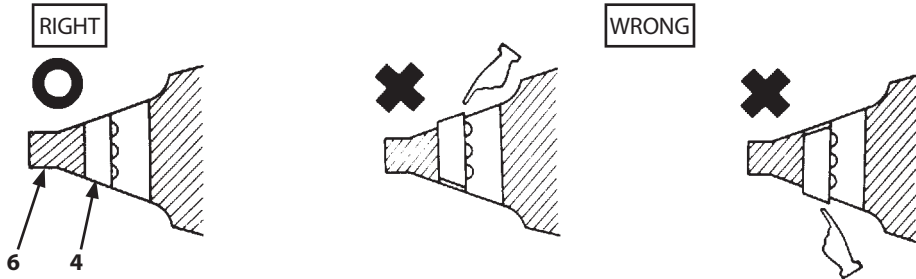

M104-07-060

- Position new tooth (1) over shank (6).

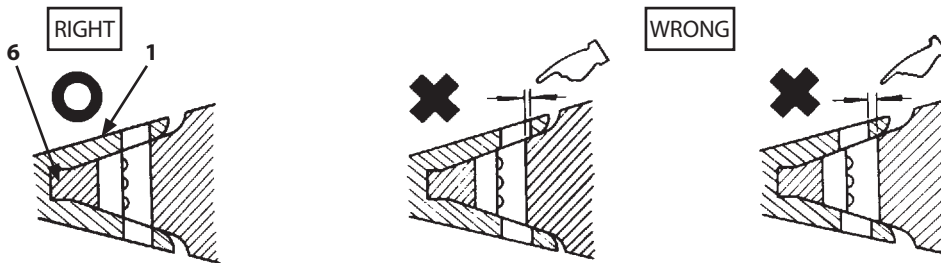

M104-07-061

- Drive lock pin (5) fully into the hole as shown.

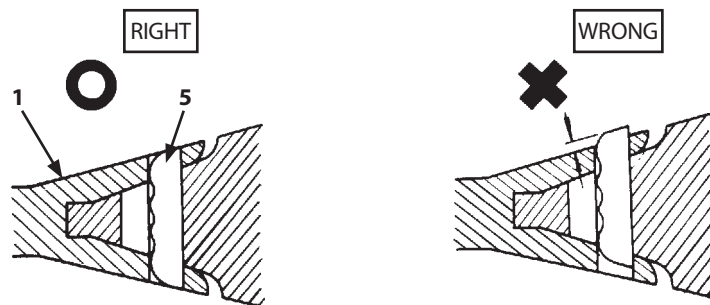

M104-07-062



## MAINTENANCE

### 3 Convert Bucket Connection Into Face Shovel

**CAUTION:** When driving the connecting pins in or out, guard against injury from flying pieces of metal or debris. Wear goggles or safety glasses, hard hat and face shield.

Converting the bucket connection allows you to use the machine as a face shovel. Before starting converting work, keep bystanders clear of the machine. Slowly move the front attachment. When using a signal person, coordinate hand signals before starting.

#### Procedure:

1. Place the bucket in a stable position.
2. Slide the O-rings out of the way, as shown.
3. Remove bucket pins A and B to separate the arm and bucket.

Clean the pins and pin bores. Apply sufficient grease to the pins and pin bores.

4. Turn the bucket 180°. Be sure the bucket will not roll.
5. Fit the arm and alternate bucket. Be sure the bucket will not roll. Install bucket pins A and B.
6. Install the locking pins and snap rings on pins A and B.
7. Install O-rings to the specified positions.
8. Apply grease to each pin.
9. Start the engine and run it at slow idle. Slowly operate the bucket in both directions to check for any interference in bucket movement.

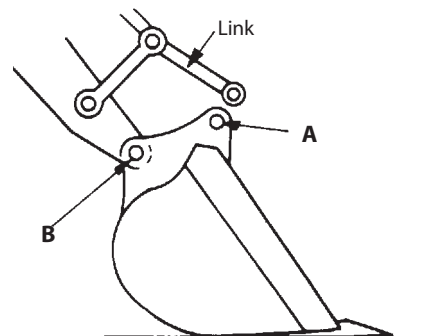
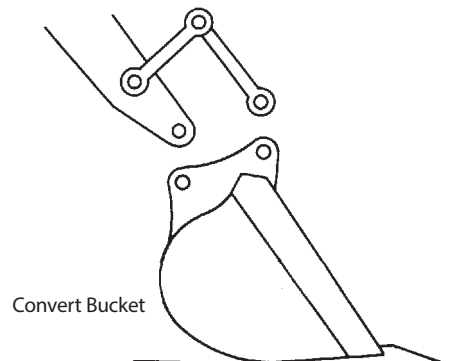
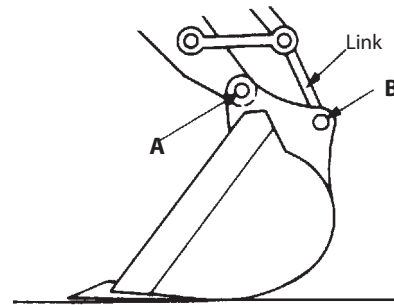
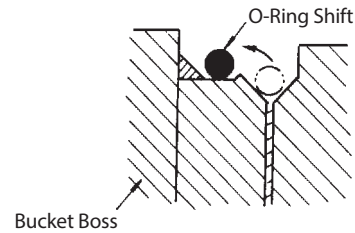

M104-07-064

## MAINTENANCE

### 4 Adjust Bucket Linkage --- as required

The machine is provided with a bucket adjustment system to take up play in the linkage. When play in the linkage increases, remove and install shims (2) as follows:

1. Place the bucket in a stable position.
2. Run the engine at slow idle. With the bucket on the ground, slowly swing counterclockwise slightly until the top of the left bucket boss contacts the arm.
3. Stop the engine. Pull the pilot control shut-off lever to the LOCK position.
4. Slightly loosen 3 bolts (1) using a 22 mm wrench. Remove all shims (2) from clearance (c) between plate (3) and bucket. As shim (2) is a dual partitioning type, it can be easily removed by slightly loosening bolt (1) and inserting tip of a screw driver into the contact surface of left and right shims (2).
5. Push and hold bolts (1) to remove all clearance (a) between arm and boss (4). Holding boss (4) against arm increases clearance (b). Install as many shims (2) into clearance (b) as possible.
6. Install remaining shims (2) into clearance (c) and tighten bolts (1) to 140 N·m (14 kgf·m).

 **NOTE:** The total number of shims (2) used in clearance (b) and (c) are  $6 \times 2 = 12$ . Remaining shims (2) must be installed in clearance (c) to prevent arm end face or bolt damage. Replace boss (4) with new one if measurement (d) is 5 mm or less.

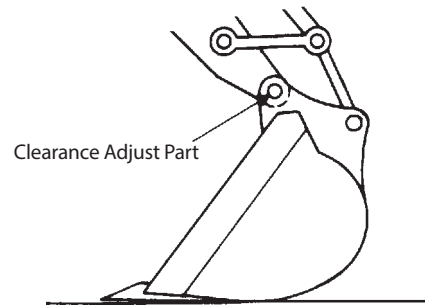

M503-07-056

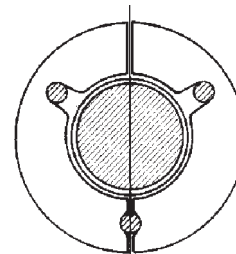
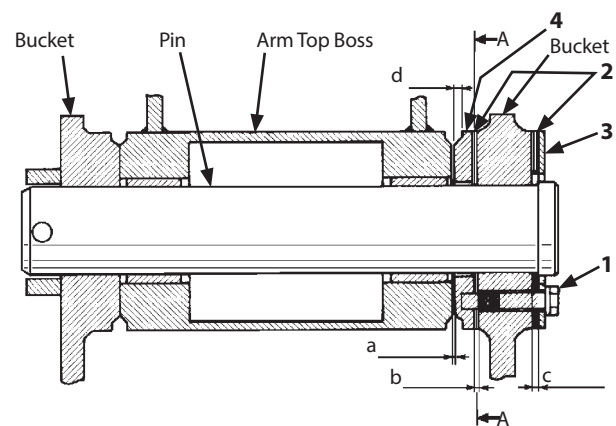

Section A

M1G6-07-010

## MAINTENANCE

### 5 Remove Travel Levers --- as required

Travel levers (3) and (4) may be removed if desired.

#### Procedure:

Remove bolts (1) and (2) to remove travel levers (3) and (4) from brackets.

 **NOTE:** Wrench size: 17 mm

Tightening Torque: 50 N·m (5.0 kgf·m)

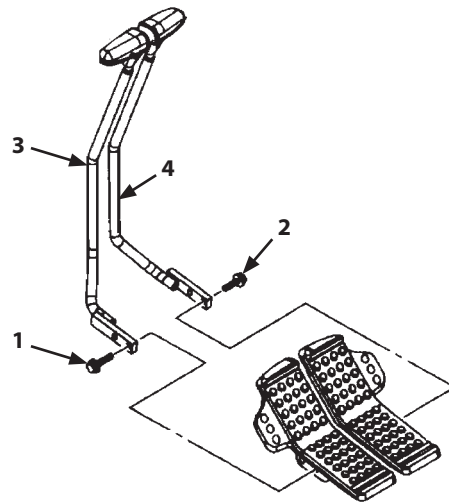

M178-07-077

### 6 Check and Replace Seat Belt Check --- daily Replace --- every 3 years

Prior to operating the machine, thoroughly examine belt (5), buckle (6) and attaching hardware (7). If any item is damaged or materially worn, replace seat belt (5) or component before operating the machine.

We recommend that seat belt (5) should be replaced every 3 years regardless of its apparent condition. Consult your authorized dealer for replacement.

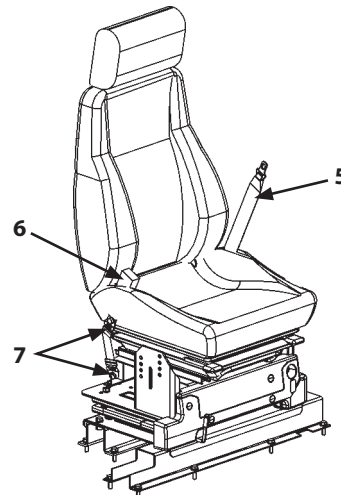

M1U1-07-008

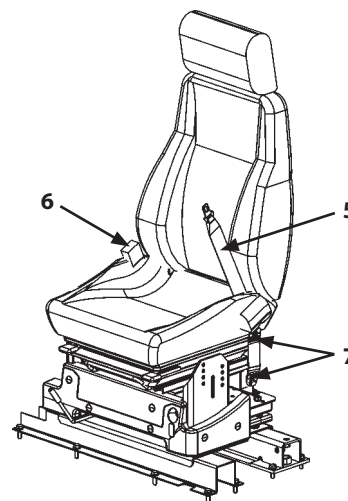

M1U1-07-009

## MAINTENANCE

### 7 Check Windshield Washer Fluid Level --- as required

Check fluid in windshield washer tank (1). If the fluid level is low, remove cap (2) and add fluid via the opening.

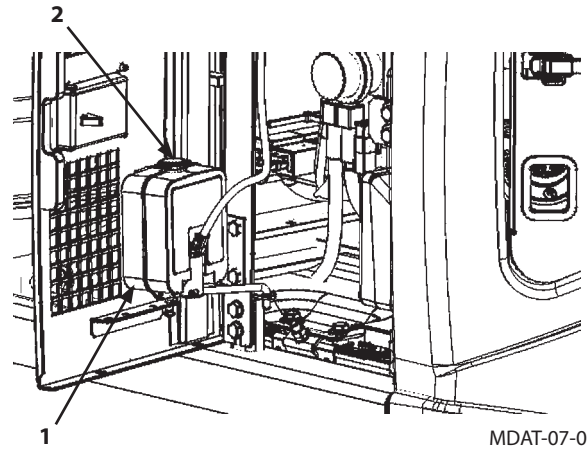

ZX135US-6

MDAT-07-032

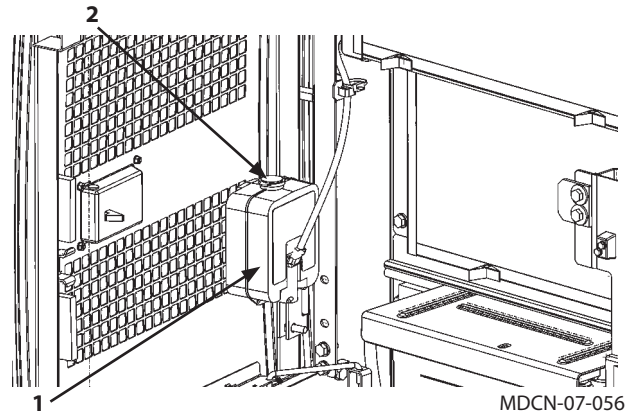

ZX225USLC-6

MDCN-07-056

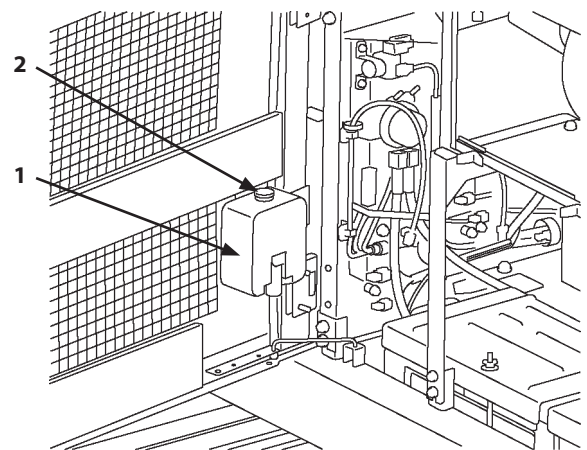

ZX345USLC-6

MDD5-07-021

## MAINTENANCE

### 8 Check Track Sag --- every 50 hours

If the amount of sag is inappropriate, the tracks may flap around or come off. This in turn may damage the track itself and other parts.

As such issues will have an effect on the lifetime of the machine, be sure to adjust the sag of the tracks to a suitable amount.

To measure or adjust the tracks, park the machine on firm and level ground.

#### Measurement Procedure with Track Raised

1. Raise a track as illustrated at right to measure its sag, and support it securely with blocks or the like.

**CAUTION:** Take care that no hands, feet, or other body parts are put beneath the track.

2. Remove any deposits on mating parts of the tracks and undercarriage (top/bottom rollers, idler, sprockets).

**IMPORTANT:** Accurate measurements cannot be taken if there are deposits on mating parts of the tracks and undercarriage (top/bottom rollers, idler, sprockets).

3. Rotate the track in reverse to eliminate track looseness on the upper side of the side frame.
4. As illustrated at right, take measurements midway (A) between the reduction gear and the idler (bottom of side frame to top of shoe).

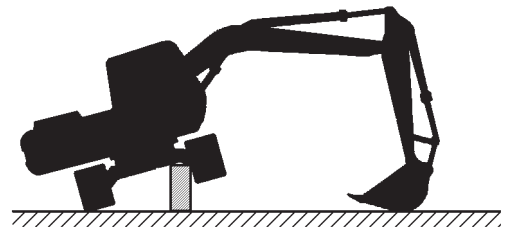

M104-07-067

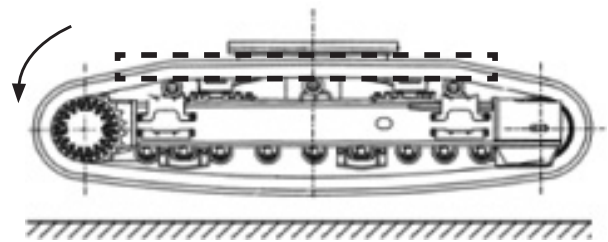

MDFY-07-149

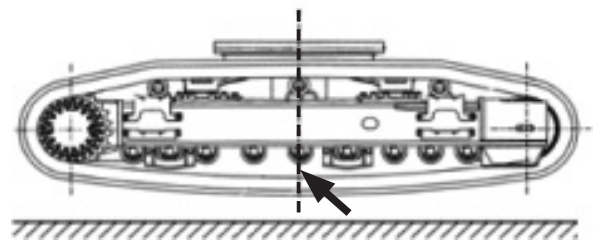

MDFY-07-149

Model	Appropriate sag A (mm)
ZX135US-6	250 to 380
ZX225USLC-6	300 to 335
ZX345USLC-6	340 to 380

If track sag is not within specifications, loosen or tighten the track.

#### Adjust Track Sag

1. Adjust the tracks one at a time, with the track in the air. When doing so, be sure to place blocks under the machine frame to support the machine.
2. After adjusting the sag on both track, rotate the tracks backward and forward to equalize the sag on both sides.
3. Recheck the track sag one more time. Readjust as necessary.

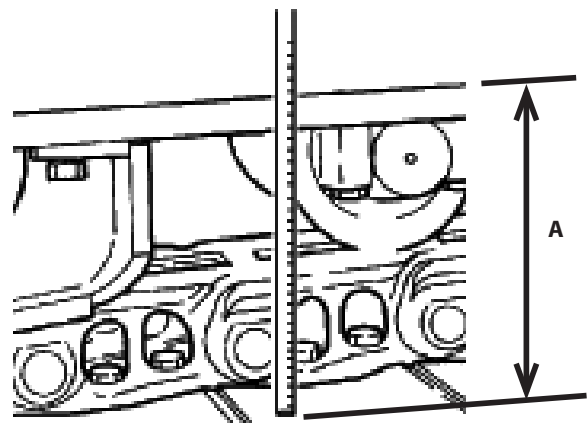

MDFY-07-150

## MAINTENANCE

### Simple Method

1. Remove any deposits on mating parts of the tracks and undercarriage (top/bottom rollers, idler, sprockets).

**IMPORTANT:** Accurate measurements cannot be taken if there are deposits on mating parts of the tracks and undercarriage (top/bottom rollers, idler, sprockets).

2. Move forward in the direction of idler (1), traveling a distance equivalent to at least the length of ground contact by the machine.
3. Stop the machine in a state where one of the track pins (4) is directly over upper roller (2).
4. As shown in the illustration to the right, place the straight rod (3) (squared timber etc.) on the section of track between idler (1) and upper roller (2).
5. Measure the maximum sag between the upper surface of the track and the bottom surface of the rod. (Dimension B in the illustration)

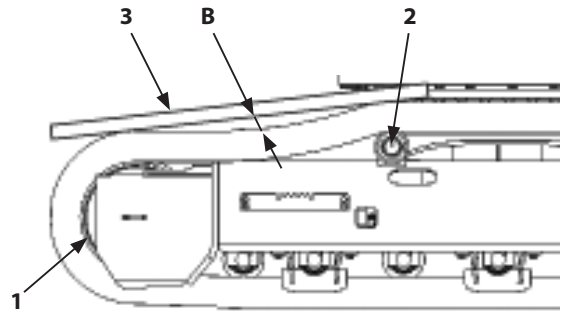

MDFY-07-100

Model	Appropriate sag B (mm)
ZX135US-6	20 to 40
ZX225USLC-6	15 to 35
ZX345USLC-6	15 to 35

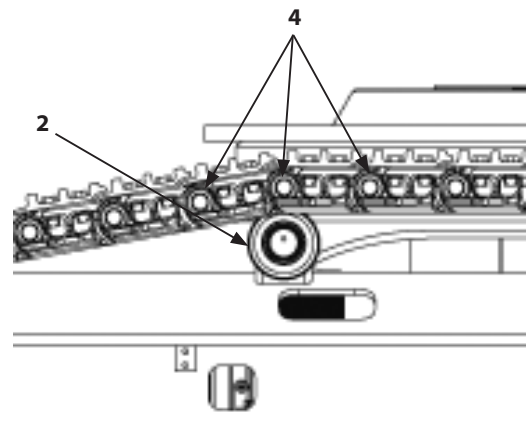

MDFY-07-101

### Adjust Track Sag

1. If track sag is not within the specified range, adjust it by loosening or tightening the track (refer to the procedures on the next page).
2. After adjusting the sag on both track, rotate the tracks backward and forward to equalize the sag on both sides.
3. Recheck the track sag one more time. Readjust as necessary.

**CAUTION:** When adjusting the sag with the track raised, be sure to place blocks under the machine frame to support the machine. During adjustment, never put hands, feet, or other parts of the body beneath the track.



## MAINTENANCE

### Loosen the Track

ZX135US-6

#### **CAUTION:**

- The pressure inside the cylinder of the track adjuster is high. Do not loosen valve (1) quickly or loosen it too much as valve (1) may fly out or high-pressure grease in the adjusting cylinder may spout out. Slowly loosen valve (1) while keeping body parts and face away from valve (1). Never loosen grease fitting (2).
- To prevent accidents, care should be taken to ensure that hands, feet, and any body parts do not become entangled when working around the tracks.

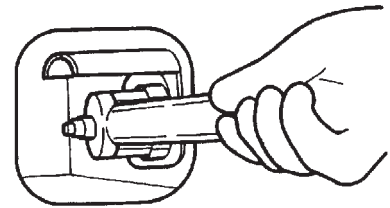

M107-07-075

**IMPORTANT:** When gravel or mud is packed between sprockets and track links, remove it before loosening.

1. To loosen the track, slowly turn valve (1) counterclockwise using long socket 19; grease will escape from the grease outlet.
2. Between 1 to 1.5 turns of valve (1) is sufficient to loosen the track.
3. If grease does not drain smoothly, slowly rotate the raised track.
4. When proper track sag is obtained, turn valve (1) clockwise and tighten to 90 N·m (9.0 kgf·m).

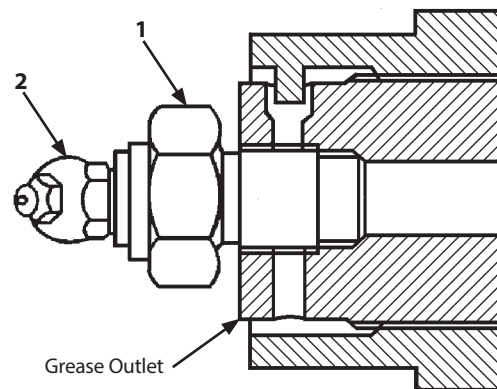

M104-07-119

### Tighten the Track

**CAUTION:** It is abnormal if the track remains tight after turning valve (1) counterclockwise or if the track is still loose after charging grease to fitting (2). In such cases, NEVER ATTEMPT TO DISASSEMBLE the track or track adjuster, because of dangerous high-pressure grease inside the track adjuster. See your authorized dealer immediately.

To tighten the track, connect a grease gun to grease fitting (2) and add grease until the sag is within specifications.

## MAINTENANCE

### ZX225USLC-6, 345USLC-6

#### CAUTION:

- The pressure inside the cylinder of the track adjuster is high. Do not loosen valve (1) quickly or loosen it too much as valve (1) may fly out or high-pressure grease in the adjusting cylinder may spout out. Slowly loosen valve (1) while keeping body parts and face away from valve (1). Never loosen grease fitting (2).
- To prevent accidents, care should be taken to ensure that hands, feet, and any body parts do not become entangled when working around the tracks.

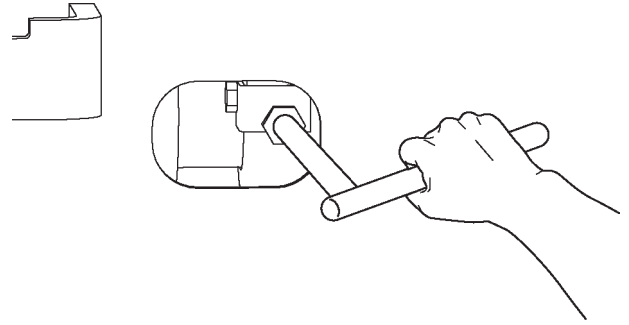

MDAA-07-013

#### **IMPORTANT:** When gravel or mud is packed between sprockets and track links, remove it before loosening.

1. To loosen the track, slowly turn valve (1) counterclockwise using long socket 24; grease will escape from the grease outlet.
2. Between 1 to 1.5 turns of valve (1) is sufficient to loosen the track. When valve (1) comes in contact with stop plate (3), do not loosen valve (1) further.
3. If grease does not drain smoothly, slowly rotate the raised track.
4. When proper track sag is obtained, turn valve (1) clockwise to the original condition.

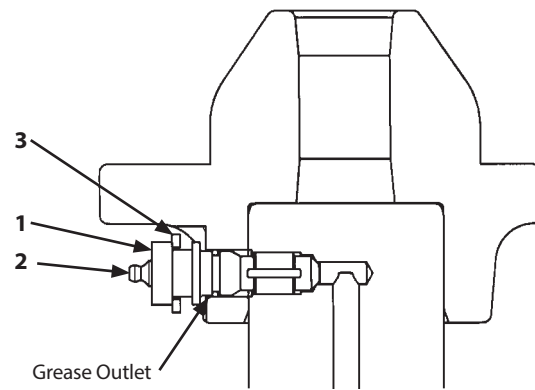

MDAA-07-014

Tightening Torque: 90 N·m (9.0 kgf·m)

Do not remove valve stop plate (3). Do not loosen bolt (4) while adjusting the track sag.

#### CAUTION: Consult your authorized dealer if grease is not sufficiently drained.

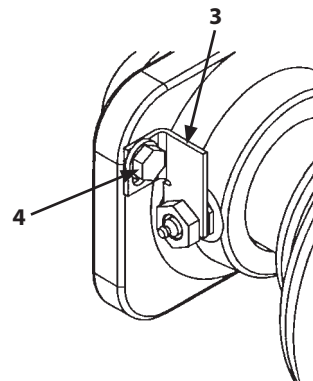

MDAA-07-057

## MAINTENANCE

---

### Tighten the Track

**⚠ CAUTION:** It is abnormal if the track can not be adjusted. The strong force acts on the spring in track adjuster. Therefore, the grease in cylinder is highly pressurized. In such cases, **NEVER ATTEMPT TO DISASSEMBLE** the track or track adjuster, because of dangerous high-pressure grease inside the track adjuster. See your authorized dealer immediately.

To tighten the track, connect a grease gun to grease fitting (2) and add grease until the sag is within specifications.

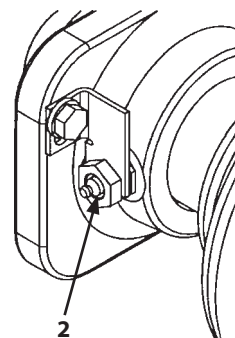

MDAA-07-057

# MAINTENANCE

## 9 Clean and Replace Air Conditioner Filter

### Clean Circulating/Fresh Air Filters

Circulating Air Filter --- every 500 hours

Fresh Air Filter --- every 500 hours

### Replace Circulating/Fresh Air Filters

Circulating Air Filter --- After cleaning 6 times or so

Fresh Air Filter --- After cleaning 6 times or so

### Removing Fresh Air Filter

#### ZX135US-6, 225USLC-6

1. Grasp the upper section of filter cover (1) and pull to remove filter cover (1).
2. Grasp the grip on fresh air filter (2) through the opening from which filter cover (1) is removed and pull to remove fresh air filter (2).

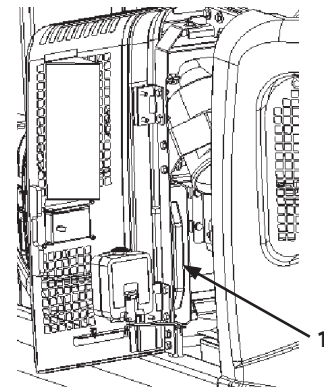

ZX135US-6

MDCN-07-009

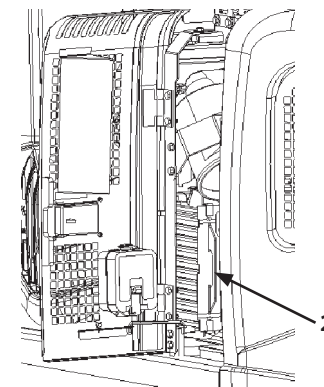

ZX135US-6

MDCN-07-057

#### ZX345USLC-6

1. Insert the key into keyhole (2) on left cab side cover (1). Then, rotate the key counterclockwise to unlock the key. Open cover (1).
2. While pressing knobs (4) on both sides of fresh air filter (3) inward, horizontally remove fresh air filter (3).

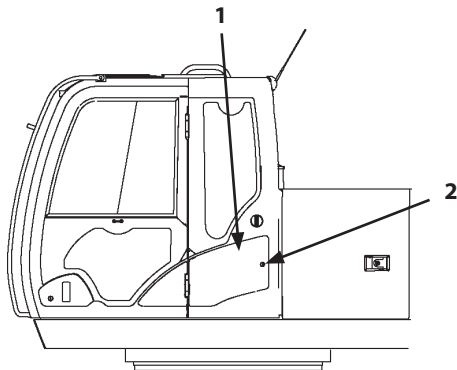

ZX345USLC-6

MDAA-07-040

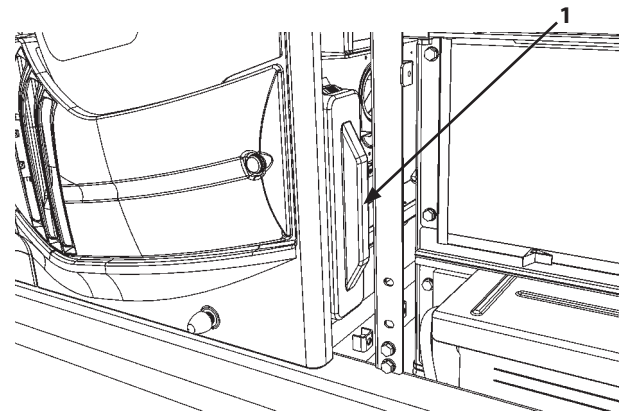

ZX225USLC-6

MDCN-07-058

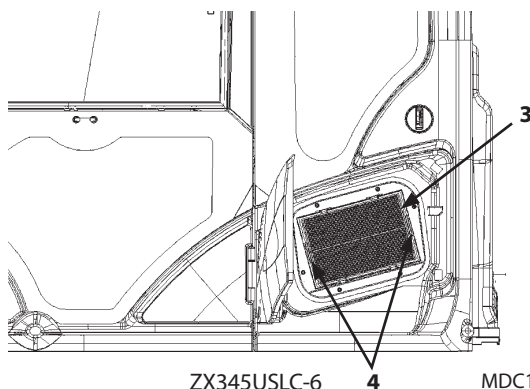

ZX345USLC-6

MDC1-07-045

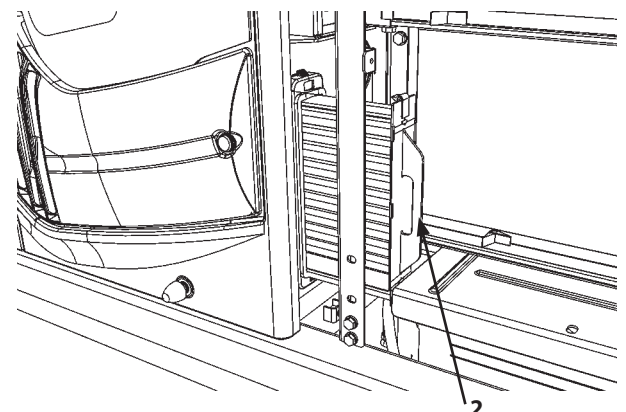

ZX225USLC-6

MDCN-07-059

## MAINTENANCE

### Removing Circulating Air Filter (Outside)

#### ZX135US-6, 225USLC-6

1. Circulating air filter (outside) (1) is located beside the seat stand.
2. Remove screws (2). Remove circulating air filter (outside) cover (3) by pulling it toward the cab front.
3. Remove screws (4). Remove circulating air filter (outside) (1) by sliding it to the arrow direction.

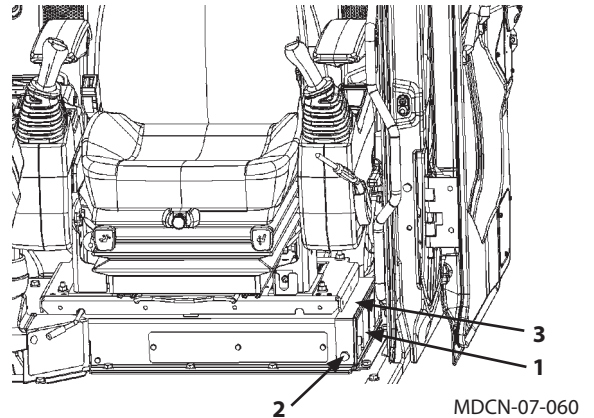

ZX135US-6, 225USLC-6

### Removing Circulating Air Filter (Inside)

#### ZX135US-6, 225USLC-6

1. Remove circulating air filter (inside) (5) by holding grip (6) and pulling it toward you through the opening for cover (3).

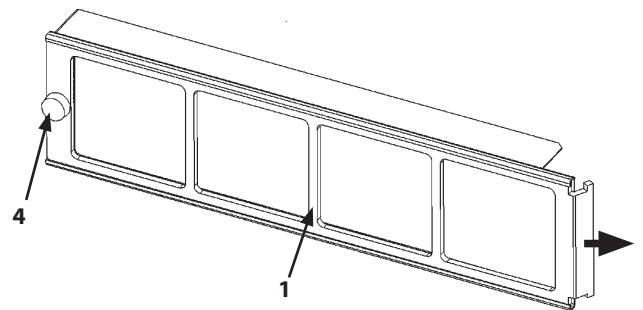

ZX135US-6, 225USLC-6

### Removing Circulating Air Filter

#### ZX345USLC-6

1. Circulating air filter (5) is located under the rear tray.
2. Holding grips (6), pull them toward you to remove.

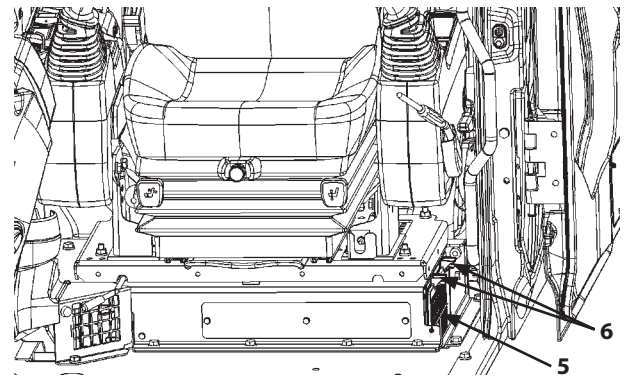

ZX135US-6, 225USLC-6

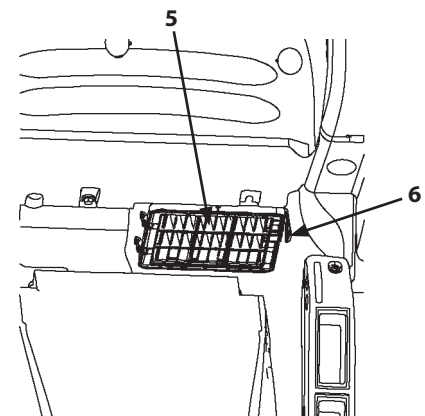

ZX345USLC-6

## MAINTENANCE

**WARNING:** When using compressed air pressure, wear safety glasses or goggles.

### Cleaning

Clean the circulating and fresh air filters.  
Clean both the external and internal filters by blowing compressed air or washing with water.

Washing procedure with water is as follows:

1. Use tap water.
2. Submerge the filter in water containing a neutral detergent for about 5 minutes.
3. Clean the filter with water again.
4. Dry the filters.

### Installation

#### ZX135US-6, 225USLC-6

- Fresh air filter (2)  
Install fresh air filter (2) so that the direction of the arrow points inside the cab.  
After installing fresh air filter (2), install the filter cover by fitting it with the duct.
- Circulating Air Filter (Inside) (7)  
Install filter (rear section in two pieces) (7) into the groove and slide it toward the cab rear side. Then, install filter (front section in two pieces) (7) into the groove.
- Latch circulating air filter (outside) (5) into the seat stand.  
Slide it toward the cab rear side and secure it with screw (6).

#### ZX345USLC-6

When installing the cleaned circulating/fresh air filters or new filters, follow the reverse order of the Removing Filter procedures described on the previous page.

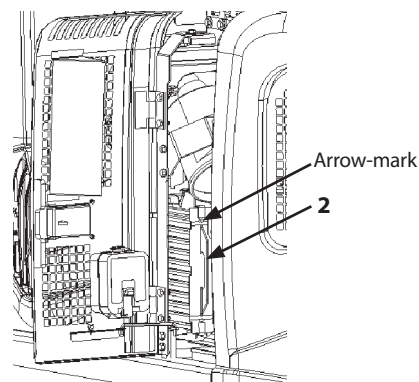

ZX135US-6

MDCN-07-057

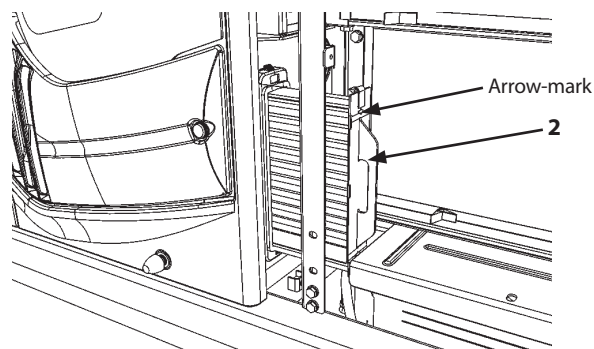

ZX225USLC-6

MDCN-07-059

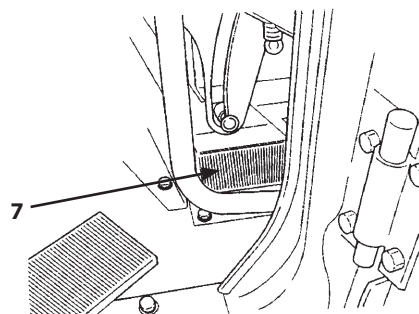

M1CC-07-013

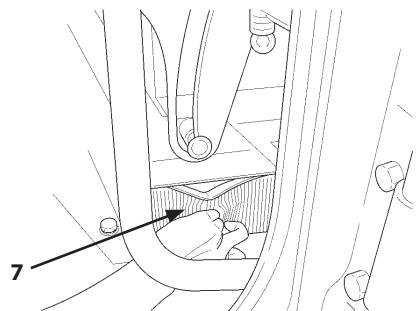

M1CC-07-012

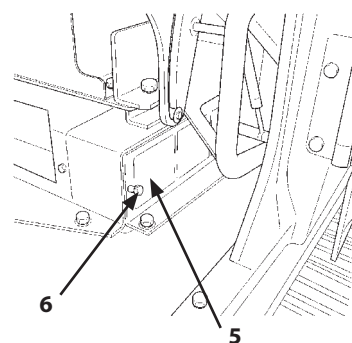

M1U4-07-020

## MAINTENANCE

### 10 Check Air Conditioner --- every 250 hours

#### Check pipe connections for refrigerant gas leakage

If oil seepage is found around pipe connections, it indicates possible gas leakage.

#### Check Refrigerant

Start the engine and run it at approximately 1500 min<sup>-1</sup> (rpm). Turn the air conditioner switch to ON. Set the fan switch to HI and set the temperature control switch to the coolest position (18 °C on the monitor screen). Operate the air conditioner 2 to 3 minutes. Check if cool air comes out from the vent in the cab.

#### Type and amount of refrigerant when shipping the machine

Model	Type	Amount
ZX135US-6, 225USLC-6, 345USLC-6	HFC134a	0.85±0.05 kg

#### Check the condenser

If the condenser fins become clogged with dirt or insects, the cooling effect will be decreased.

Be sure to keep it clean at all times. (Refer to "Clean Radiator/Oil Cooler/Inter Cooler Core" in Maintenance Chapter.)

#### Check compressor

After operating the air conditioner for 5 to 10 minutes, touch both the high pressure pipe and the low pressure pipe.

If normal, the high pressure side pipe will be hot, and the low pressure side cold.

#### Check mounting bolts for looseness

Confirm that the compressor mounting bolts and other mounting/fastening bolts are securely tightened.

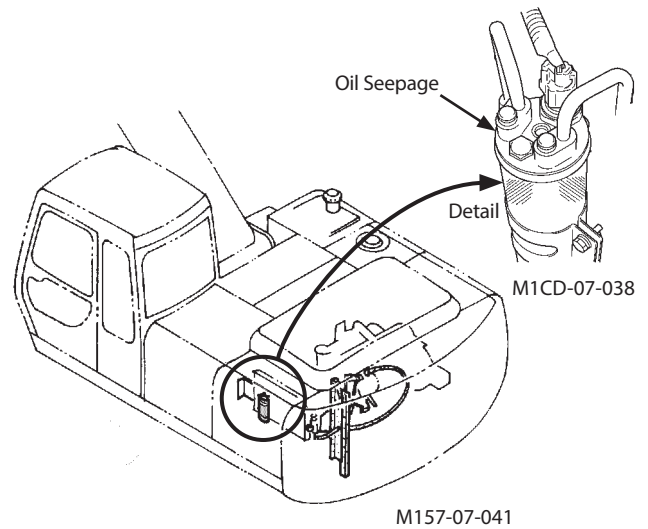

## MAINTENANCE

### Inspect belt, check and adjust tension

--- every 250 hours

Visually check the compressor and fan belts for wear. Check fan belt tension by depressing the midpoint of the belt with the thumb. Deflection must be shown in the right figure with a depressing force of approximately 98 N (10 kgf).

If cool air does not come out, or any other abnormalities are found in air conditioner system, see your authorized dealer for inspection.

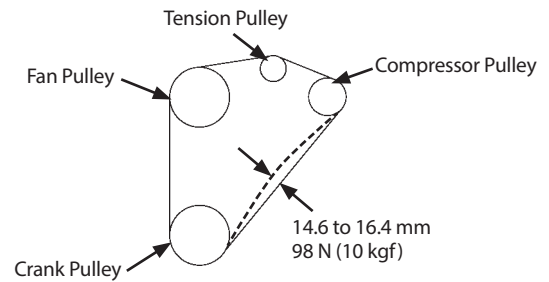

ZX135US-6

M1U1-07-086

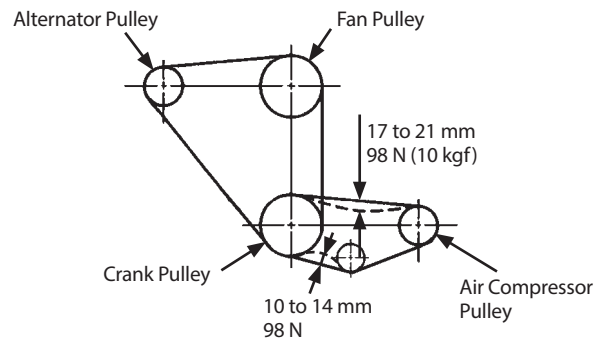

ZX225USLC-6, 345USLC-6

M1GR-07-007

### Adjust Compressor Belt Tension

1. Loosen lock nut (2) of tension pulley (1).
2. Move tension pulley (1) by adjusting bolt (3) under tension pulley (1) until tension is correct.
3. Securely tighten bolt (2) of tension pulley (1).
4. After that tighten bolt (3).

**IMPORTANT:** When a new belt is installed, be sure to re-adjust the tension after operating the engine for 3 to 5 minutes at slow idle speed to be sure that the new belt is seated correctly.

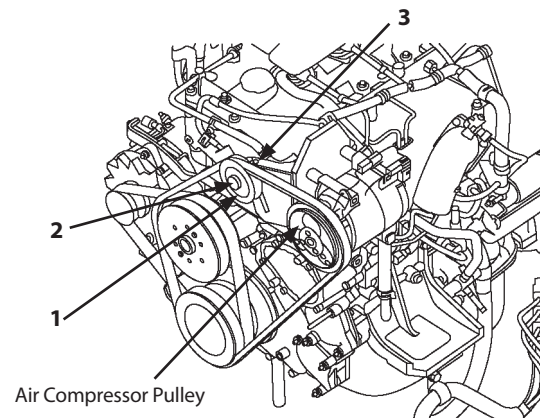

ZX135US-6

M1U4-07-041

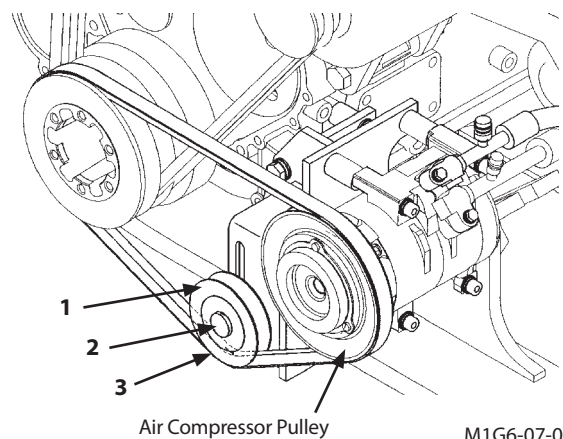

Air Compressor Pulley

ZX225USLC-6, 345USLC-6

M1G6-07-013



## MAINTENANCE

### 11 Clean Cab Floor

--- as required

**IMPORTANT:** When cleaning the cab floor with tap water, spray the floor only. Take care not to splash the surrounding area. Do not increase water spray speed by restricting the hose end, and do not use high pressure steam for cleaning. Be sure to completely remove any moisture from the surrounding area.

#### ZX135US-6, 225USLC-6

1. Park the machine on solid and level surface. Lower the bucket to the ground. Before cleaning, stop the engine. Protect the air conditioner in-cab air suction port and the foot air vent with covers (1) and (2) stored in the pocket behind the backrest.
2. Remove screws (3) under the floor mat. Remove circulating air filter (outside) cover (4). Remove the circulating air filter (outside) from circulating air filter (outside) cover (4). Install cover (1) with screws (5) in the position where the circulating air filter was installed. Secure circulating air filter (outside) cover (4) with screws (3). Remove foot air vent holding screws (6). Attach cover (2) onto the foot air vent and secure it with screws (6).

**IMPORTANT:** Never fail to do this preparation work.

**Failure to do so may result in damage/failure of the air conditioner.**

3. Sweep the cab floor clean using a brush, and brush dust from the cab floor while spraying water.
4. When cleaning the floor mat, sweep dust (water) along the grooves on the floor mat.
5. When cleaning after removing the floor mat, sweep dust (water) through two cleaning holes.
6. After cleaning, remove covers (1) and (2) from the air conditioner in-cab suction hole and the foot air vent while following the above steps in reverse. Install the circulating air filter. (Refer to the descriptions for Clean and Replace Circulating Air Filter and Fresh Air Filter.) Store covers (1) and (2) in the pocket behind the backrest.

**IMPORTANT:** If the A/C is operated without removing the cover, the A/C will not operate efficiently so that its cooling ability is reduced.

#### ZX345USLC-6

1. Park the machine on solid and level surface. Lower the bucket to the ground. Before cleaning, stop the engine.
2. Sweep the cab floor clean using a brush, and brush dust from the cab floor while spraying water.
3. When cleaning the floor mat, sweep dust (water) along the grooves on the floor mat.
4. When cleaning after removing the floor mat, sweep dust (water) through one cleaning hole.

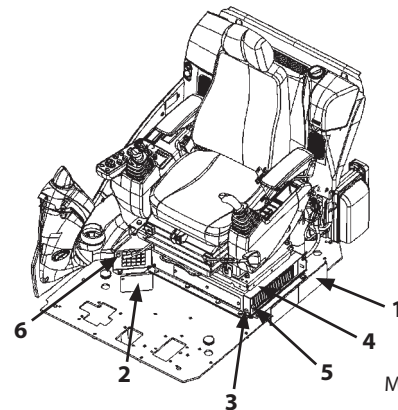

MDCN-07-063

ZX135US-6, 225USLC-6

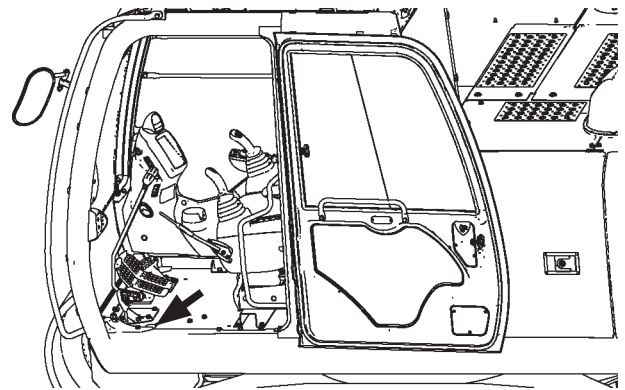

ZX345USLC-6

MDAA-07-041

## MAINTENANCE

---

- 12** **Retighten Cylinder Head Bolt**  
--- as required

See your authorized dealer.

- 13** **Inspect and Adjust Valve Clearance**  
--- every 1000 hours

See your authorized dealer.

- 14** **Measure Engine Compression Pressure**  
--- every 1000 hours

See your authorized dealer.

- 15** **Check Starter and Alternator**  
--- every 1000 hours

See your authorized dealer.

- 16** **Check and Replace EGR Device**  
--- as required

See your authorized dealer.

- 17** **EGR Cooler Cleaning**  
--- every 4500 hours

See your authorized dealer.

- 18** **Check Turbo Charger**  
--- every 4500 hours

See your authorized dealer.

## MAINTENANCE

---

### **19** Check and Clean Injector --- as required

See your authorized dealer.

### **20** Check Gas Damper --- as required

**⚠ CAUTION:** The gas damper has been charged with high-pressure nitrogen gas. Inappropriate handling may cause explosion, possibly resulting in serious injury or death.

Gas dampers are used in the overhead window of the cab. Contact your authorized dealer immediately in any of the following situations.

- The cover or window can not be opened with normal operating force.
- The cover or window can not maintain its open position.
- Oil or gas leak is found.

### **21** Tightening and Retightening Torque of Nuts and Bolts --- every 250 hours (first time after 50 hours)

Tighten or retighten nuts and bolts used on this machine in accordance with the torque values shown in the following table. Check daily for missing or loose nuts and bolts before and after operation. If any loose or missing nuts and/or bolts are found, retighten or supply replacement parts. Check tightness after the first 50 hours then every 250 hours. The nuts and bolts other than those shown in the table below shall be tightened in accordance with the torque values shown in the table on page 7-136.

## MAINTENANCE

### ZX135US-6

No.	Descriptions	Bolt Dia	Quantity	Wrench size	Torque		
					N·m	(kgf·m)	
1.	Engine cushion rubber mounting bolt and nut	16	4	24	235	(23.5)	
2.	Engine bracket mounting bolt (Pump side)	12	8	19	110	(11)	
3.	Hydraulic oil tank mounting bolt	16	4	24	270	(27)	
4.	Fuel tank mounting bolt	16	4	24	270	(27)	
5.	Radiator mounting bolt (Lower side)	12	3	19	90	(9.0)	
6.	Pump mounting bolt	12	10	19	110	(11)	
7.	Control valve mounting bolt	16	4	24	210	(21)	
	Control valve bracket mounting bolt	16	5	24	270	(27)	
8.	Swing device mounting bolt	20	10	30	500	(50)	
9.	Swing motor mounting bolt (Hexagon wrench)	10	7	8	64	(6.4)	
10.	ORS fitting for hydraulic hose and piping	–	–	17	25	(2.5)	
		–	–	19	30	(3.0)	
		–	–	22	40	(4.0)	
		–	–	27	80	(8.0)	
		–	–	27	95	(9.5)	
		–	–	32	140	(14)	
		–	–	36	180	(18)	
11.	Hycolin® tube mounting nut	–	–	17	35	(3.5)	
12.	Battery mounting nut	10	4	17	50	(5.0)	
	Cab mounting nut	16	4	24	210	(21)	
13.	Cab mounting anchor bolt	22	1	32	550	(55)	
	Cab cushion rubber mounting bolt	12	8	19	110	(11)	
14.	Cover mounting bolt	6	–	10	–	–	
		8	–	13	–	–	
		10	–	17	50	(5.0)	
		12	–	19	90	(9.0)	
15.	Constant torque clamp of low pressure piping	–	4	8	14	(1.4)	
	Jubilee® clamp of low pressure piping	–	9	7	6	(0.6)	
	–	2	8	6	(0.6)		
	T-bolt clamp of low pressure piping	–	5	10	6	(0.6)	
16.	Swing bearing mounting bolt	(Upperstructure)	18	30	27	390	(39)
		(Undercarriage)	16	45	24	265	(26.5)
17.	Travel device mounting bolt	16	28	24	310	(31)	
	Travel reduction gear cover mounting bolt	14	8	22	175	(17.5)	
	Sprocket mounting bolt	16	32	24	265	(26.5)	
18.	Upper roller mounting bolt	12	8	19	98	(9.8)	
19.	Lower roller mounting bolt	16	56	24	300	(30)	
20.	Track shoe mounting bolt	16	352	24	410	(41)	
21.	Track guard mounting bolt	16	8	24	310	(31)	
22.	Aftertreatment device mounting bolt	Back plate	12	4	19	90	(9.0)
		Base plate	12	4	19	110	(11)
23.	DEF/AdBlue® tank bracket mounting bolt	10	3	17	50	(5.0)	
24.	Platform handrail mounting bolt	12	7	19	130	(13)	
25.	Body top handrail mounting bolt	12	4	19	130	(13)	
26.	Cab top handrail mounting bolt	16	2	24	270	(27)	
27.	Front pin-retaining bolt	18	2	27	400	(40)	

## MAINTENANCE

### ZX225USLC-6

No.	Descriptions	Bolt Dia	Quantity	Wrench size	Torque	
					N·m	(kgf·m)
1.	Engine cushion rubber mounting bolt and nut	22	4	32	550	(55)
2.	Engine bracket mounting bolt (Pump side)	16	12	24	270	(27)
	Engine bracket mounting bolt (Fan side)	10	8	17	65	(6.5)
3.	Hydraulic oil tank mounting bolt	16	4	24	270	(27)
4.	Fuel tank mounting bolt	16	6	24	270	(27)
5.	Radiator mounting bolt (Left and right)	10	6	17	50	(5.0)
	Radiator mounting bolt (Lower side)	16	3	24	270	(27)
6.	Pump mounting bolt	12	12	19	110	(11)
7.	Control valve mounting bolt	18	4	27	300	(30)
	Control valve bracket mounting bolt	16	4	24	270	(27)
8.	Swing device mounting bolt	20	14	30	500	(50)
9.	Swing motor mounting bolt (Hexagon wrench)	12	8	10	90	(9.0)
10.	ORS fitting for hydraulic hose and piping	–	–	17	25	(2.5)
		–	–	19	30	(3.0)
		–	–	22	40	(4.0)
		–	–	27	95	(9.5)
		–	–	32	140	(14)
		–	–	36	180	(18)
		–	–	41	210	(21)
11.	Hycolin® tube mounting nut	–	–	17	35	(3.5)
12.	Battery mounting nut	10	2	17	25	(2.5)
	Cab mounting nut	16	4	24	210	(21)
13.	Cab mounting anchor bolt	22	1	32	550	(55)
	Cab cushion rubber mounting bolt	12	8	19	110	(11)
14.	Cover mounting bolt	6	–	10	10	(1.0)
		8	–	13	10	(1.0)
		10	–	17	50	(5.0)
15.	Constant torque clamp of low pressure piping	–	8	8	14	(1.4)
	Flexible master coupling of low pressure piping	–	1 pair	13	10.3 to 12.4	(1.0 to 1.24)
	Jubilee® clamp of low pressure piping	–	4	7	6	(0.6)
		–	9	8	6	(0.6)
	T-bolt clamp of low pressure piping	–	9	10	6	(0.6)
16.	Swing bearing mounting bolt	20	37	30	510	(51)
		(Upperstructure)	20	36	30	490
17.	Travel device mounting bolt	20	28	30	630	(63)
	Travel reduction gear cover mounting bolt	14	8	22	180	(18)
	Sprocket mounting bolt	20	36	30	485	(48.5)
18.	Upper roller mounting bolt	16	16	24	270	(27)
19.	Lower roller mounting bolt	18	56	27	460	(46)
		18	64	27	460	(46)
20.	Track shoe mounting bolt	20	408	27	804	(80.4)
21.	Track guard mounting bolt	18	8	27	500	(50)
		18	16	27	500	(50)
22.	Aftertreatment device mounting bolt	12	8	19	90	(9.0)
23.	DEF/AdBlue® tank bracket mounting bolt	10	4	17	50	(5.0)
24.	Platform handrail mounting bolt	12	2	19	110	(11)
		14	4	22	180	(18)
25.	Body top handrail mounting bolt	12	10	19	110	(11)
26.	Cab top handrail mounting bolt	16	2	24	270	(27)
27.	Front pin-retaining bolt	18	2	27	400	(40)









## MAINTENANCE

### ZX345USLC-6

No.	Descriptions	Bolt Dia	Quantity	Wrench size	Torque			
					N-m	(kgf·m)	(lbf·ft)	
1.	Engine cushion rubber mounting bolt and nut	20	4	30	550	(55)	(410)	
2.	Engine bracket mounting bolt (Pump side)	12	12	19	110	(11)	(81)	
	Engine bracket mounting bolt (Fan side)	10	10	17	65	(6.5)	(48)	
3.	Hydraulic oil tank mounting bolt	16	6	24	270	(27)	(200)	
4.	Fuel tank mounting bolt	16	6	24	270	(27)	(200)	
5.	Radiator mounting bolt (Left and right)	10	6	17	50	(5.0)	(37)	
	Radiator mounting bolt (Lower side)	16	5	24	270	(27)	(200)	
6.	Pump mounting bolt	12	13	19	110	(11)	(81)	
7.	Control valve mounting bolt	18	4	27	300	(30)	(220)	
	Control valve bracket mounting bolt	16	4	24	270	(27)	(200)	
8.	Swing device mounting bolt	22	14	32	650	(65)	(480)	
9.	Swing motor mounting bolt (Hexagon wrench)	12	8	10	90	(9.0)	(66)	
10.	ORS fitting for hydraulic hose and piping	–	–	17	25	(2.5)	(18.5)	
		–	–	19	30	(3.0)	(22)	
		–	–	22	40	(4.0)	(29.5)	
		–	–	27	95	(9.5)	(70)	
		–	–	32	140	(14)	(103)	
		–	–	36	180	(18)	(133)	
		–	–	41	210	(21)	(155)	
11.	Hycolin® tube mounting nut	–	–	17	35	(3.5)	(26)	
12.	Battery mounting nut	10	8	17	25	(2.5)	(18.5)	
	Cab mounting nut	16	4	24	210	(21)	(155)	
13.	Cab mounting anchor bolt	22	2	32	550	(55)	(410)	
	Cab cushion rubber mounting bolt	12	8	19	110	(11)	(81)	
14.	Cover mounting bolt	8	–	13	20	(2.0)	(15)	
		10	–	17	50	(5.0)	(37)	
		12	–	19	90	(9.0)	(66)	
15.	Constant torque clamp of low pressure piping	–	8	8	14	(1.4)	(10.5)	
	Flexible master coupling of low pressure piping	–	1 pair	17	20.5 to 22.6	(2.1 to 2.3)	(15.0 to 16.5)	
	Jubilee® clamp of low pressure piping	Air cleaner I/C pipe	–	–	7	6	(0.6)	(4.4)
		For the radiator	–	–	8	6	(0.6)	(4.4)
		For the radiator (engine side)	–	–	8	6.9	(0.7)	(5.1)
T-bolt clamp of low pressure piping	–	8	11	10	(1.0)	(7.4)		
16.	Swing bearing mounting bolt	(Upperstructure)	27	36	41	1250	(125)	(920)
		(Undercarriage)	27	36	41	1230	(123)	(910)
17.	Travel device mounting bolt	20	40	30	630	(63)	(460)	
	Travel reduction gear cover mounting bolt	14	8	22	180	(18)	(133)	
	Sprocket mounting bolt	22	44	32	680	(68)	(500)	
18.	Upper roller mounting bolt	18	16	27	460	(46)	(340)	
19.	Lower roller mounting bolt	22	64	32	840	(84)	(620)	
20.	Track shoe mounting bolt	22	384	32	1128	(113)	(830)	
21.	Track guard mounting bolt	22	24	32	750	(75)	(550)	
22.	Aftertreatment device mounting bolt	12	18	19	90	(9.0)	(66)	
23.	DEF/AdBlue® tank bracket mounting bolt	10	4	17	50	(5.0)	(37)	
24.	Platform handrail mounting bolt	Frame top	14	6	22	180	(18)	(133)
		Body top, Fuel tank top	12	7	19	110	(11)	(81)
25.	Body top handrail mounting bolt	12	6	19	110	(11)	(81)	
26.	Cab top handrail mounting bolt	16	2	24	270	(27)	(200)	
27.	Front pin-retaining bolt	22	2	32	750	(75)	(550)	
	Boom top, Arm cylinder bottom and rod pin-retaining bolt	18	5	27	400	(40)	(300)	

## MAINTENANCE

### Tightening Torque Chart

Bolt Dia. mm	Hexagon Wrench						Socket Bolt			
	  		  		  		Wrench size mm	Socket Bolt		Wrench size mm
	N·m	(kgf·m)	N·m	(kgf·m)	N·m	(kgf·m)		N·m	(kgf·m)	
6					3.3 to 4.2	(0.3 to 0.4)	10			5
8	30	(3.0)	20	(2.0)	10	(1.0)	13	20	(2.0)	6
10	65	(6.5)	50	(5.0)	20	(2.0)	17	50	(5.0)	8
12	110	(11)	90	(9.0)	35	(3.5)	19	90	(9.0)	10
14	180	(18)	140	(14)	55	(5.5)	22	140	(14)	12
16	270	(27)	210	(21)	80	(8.0)	24	210	(21)	14
18	400	(40)	300	(30)	120	(12)	27	300	(30)	14
20	550	(55)	400	(40)	170	(17)	30	400	(40)	17
22	750	(75)	550	(55)	220	(22)	32			
24	950	(95)	700	(70)	280	(28)	36			
27	1400	(140)	1050	(105)	400	(40)	41			
30	1950	(195)	1450	(145)	550	(55)	46			
33	2600	(260)	1950	(195)	750	(75)	50			
36	3200	(320)	2450	(245)	950	(95)	55			

**⚠ CAUTION:** If fixing bolts for counterweight are loosened, consult your nearest authorized dealer.

#### IMPORTANT:

- Apply lubricant (e. g. white zinc B solved into spindle oil) to bolts and nuts to stabilize their friction coefficient.
- Remove soil, dust, and/or dirt from the nut and bolt thread surfaces before tightening.
- Tighten nuts and bolts to specifications. If tightened with excessively low or high torque, missing or breakage of nuts and/or bolts may result.

# MAINTENANCE

## 1. Engine cushion rubber mounting bolts and nuts

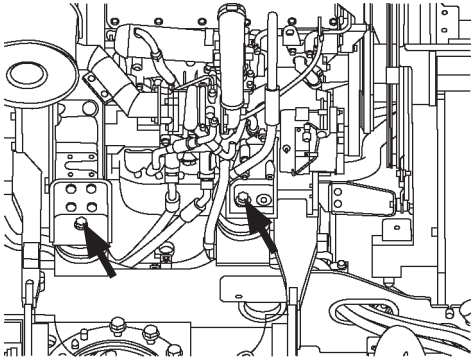

ZX135US-6

M1U4-07-046

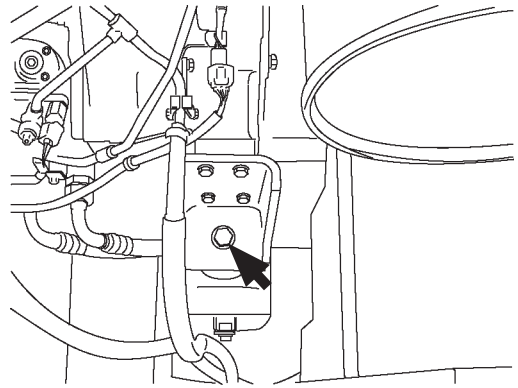

Pump Side  
ZX225USLC-6, 345USLC-6

M1U1-07-040

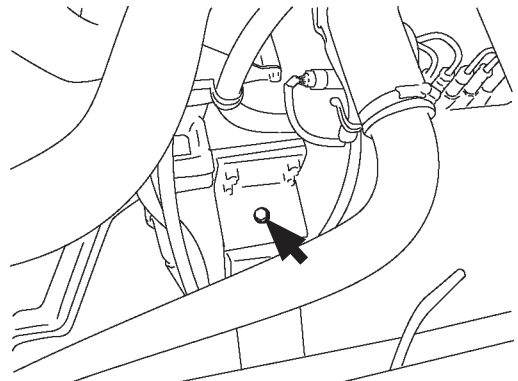

Fan Side  
ZX225USLC-6, 345USLC-6

M1U1-07-034

## 2. Engine bracket mounting bolts

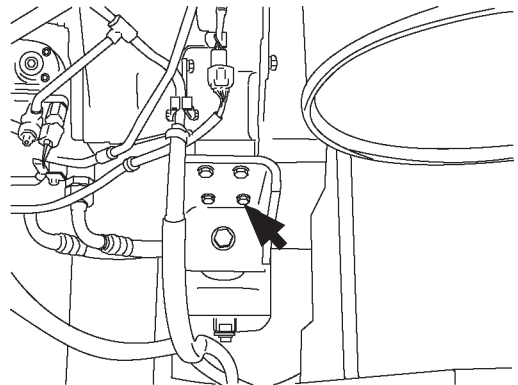

Pump Side

M1U1-07-040

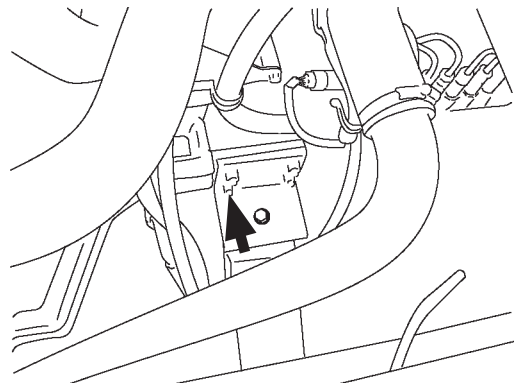

Fan Side  
ZX225USLC-6, 345USLC-6

M1U1-07-034



# MAINTENANCE

## 3. Hydraulic oil tank mounting bolts

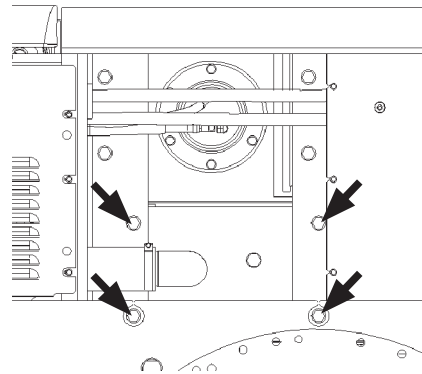

ZX135US-6

MDCN-07-064

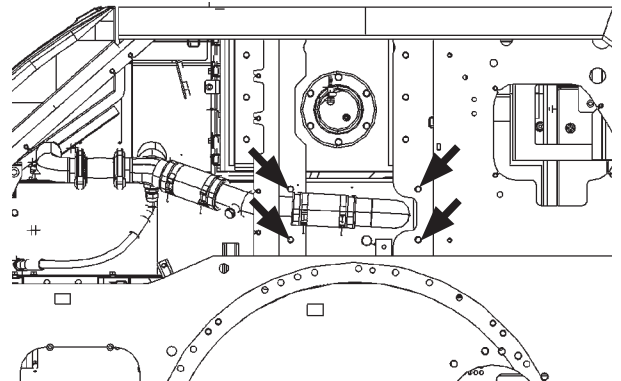

ZX225USLC-6

MDCN-07-065

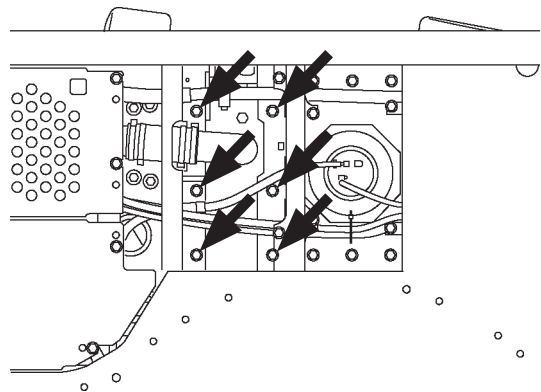

ZX345USLC-6

MDD5-07-022

# MAINTENANCE

## 4. Fuel tank mounting bolts

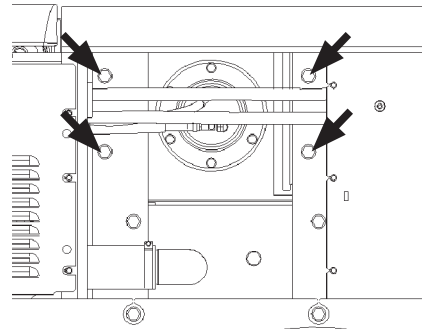

ZX135US-6

MDCN-07-064

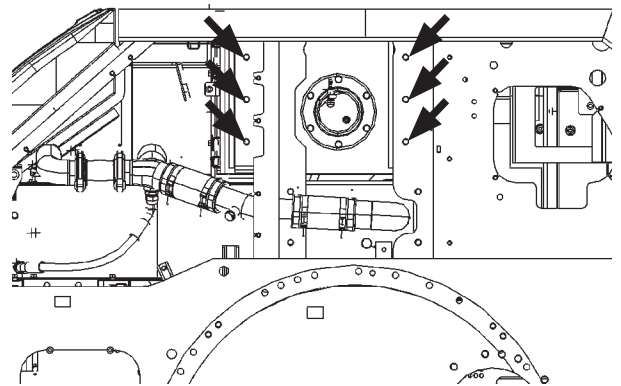

ZX225USLC-6

MDCN-07-065

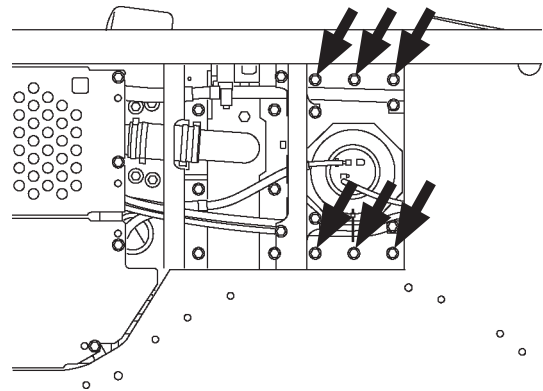

ZX345USLC-6

MDD5-07-022

# MAINTENANCE

## 5. Radiator mounting bolts

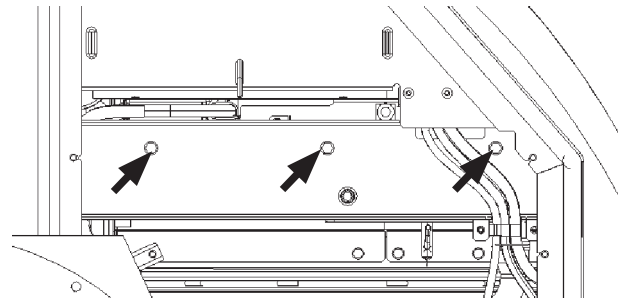

ZX135US-6

MDCN-07-066

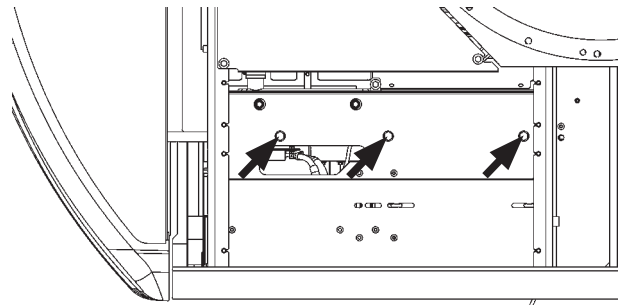

ZX225USLC-6

MDCN-07-067

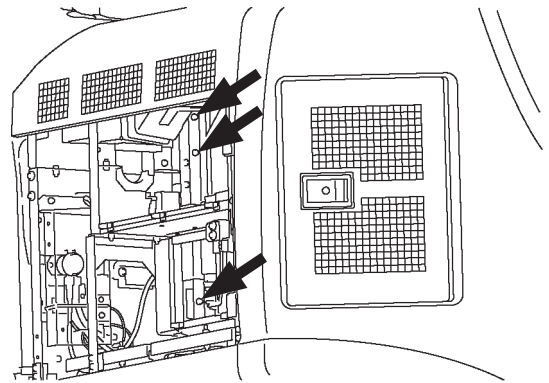

ZX345USLC-6

MDD5-07-023

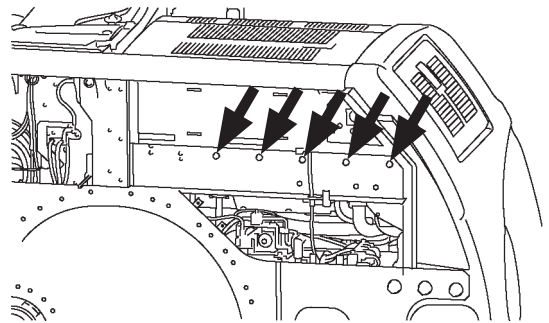

ZX345USLC-6

MDD5-07-024

# MAINTENANCE

## 6. Pump mounting bolts

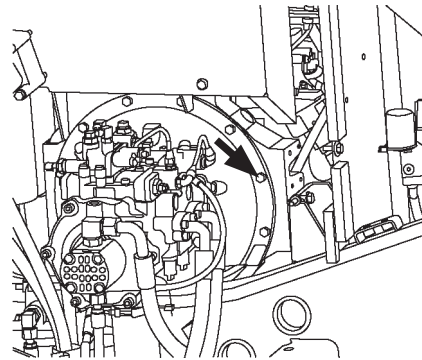

ZX135US-6

M1U4-07-050

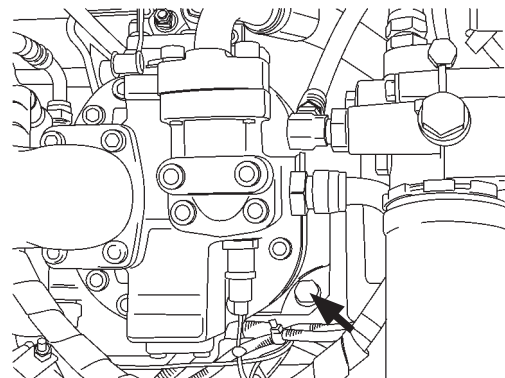

ZX225USLC-6

M1U1-07-021

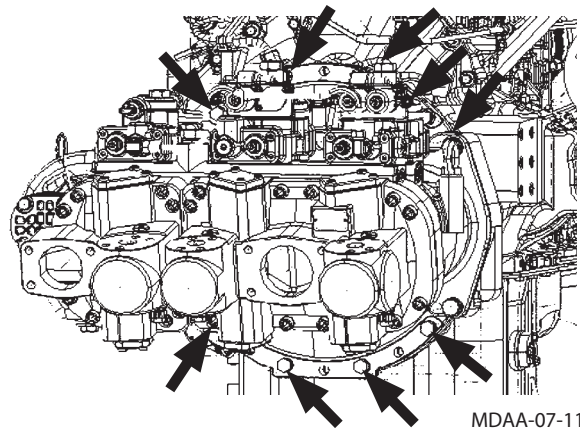

ZX345USLC-6

MDAA-07-110

# MAINTENANCE

## 7. Control valve mounting bolts

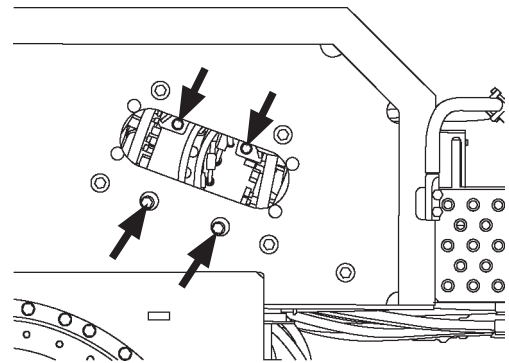

ZX135US-6

M1U4-07-051

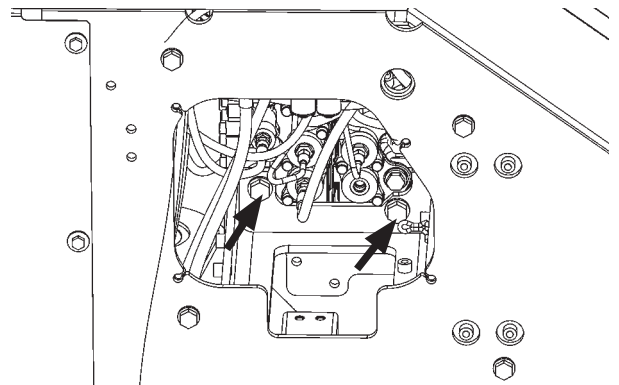

ZX225USLC-6

MDCN-07-068

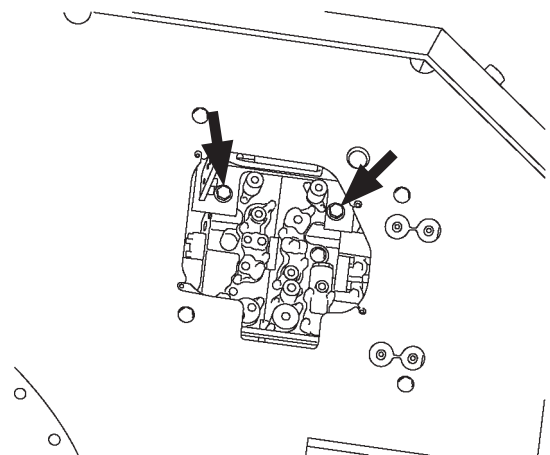

ZX345USLC-6

MDD5-07-025

# MAINTENANCE

## Control valve bracket mounting bolts

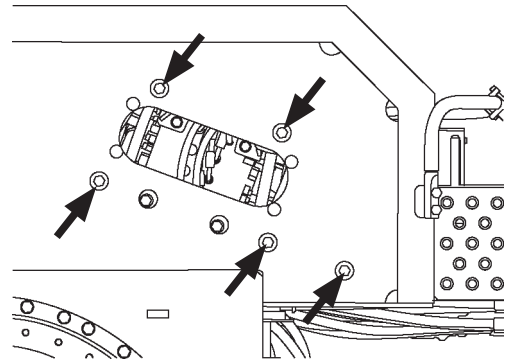

ZX135US-6

M1U4-07-051

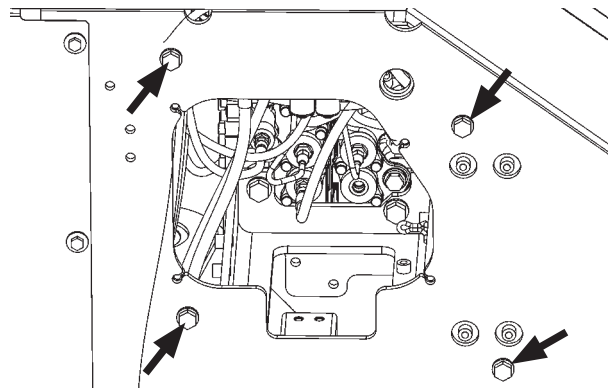

ZX225USLC-6

MDCN-07-068

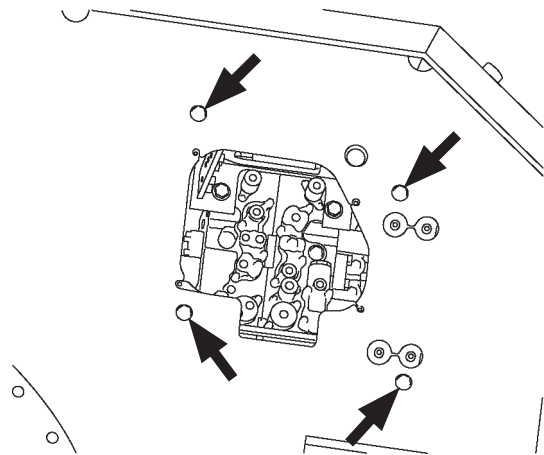

ZX345USLC-6

MDD5-07-025

# MAINTENANCE

## 8. Swing device mounting bolts

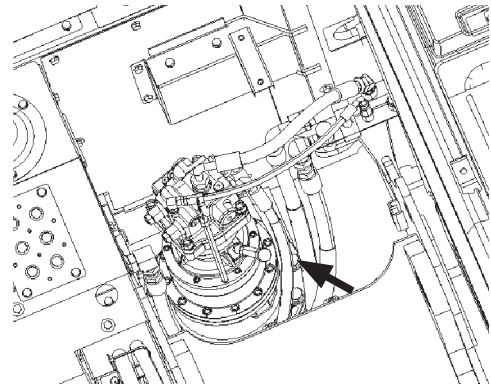

ZX135US-6

MDCN-07-018

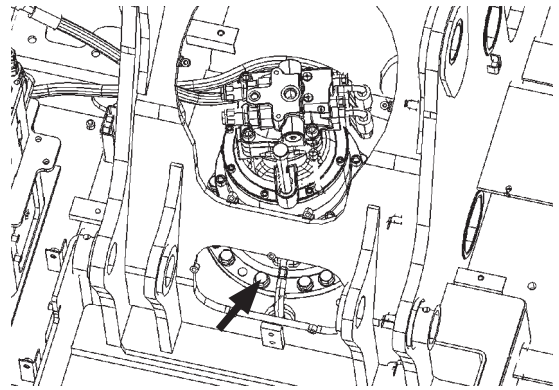

ZX225USLC-6

MDCN-07-069

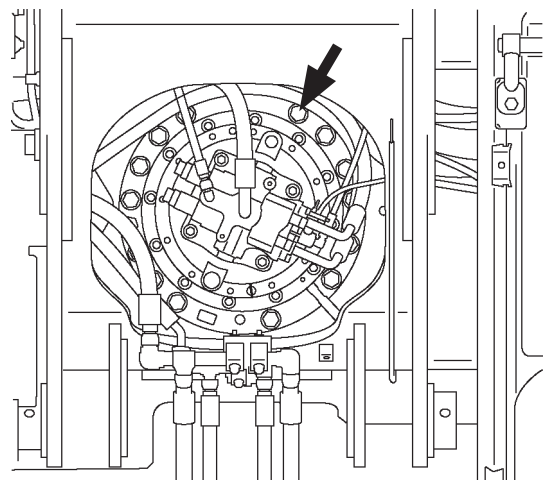

ZX345USLC-6

MDD5-07-026

# MAINTENANCE

## 9. Swing motor mounting bolts

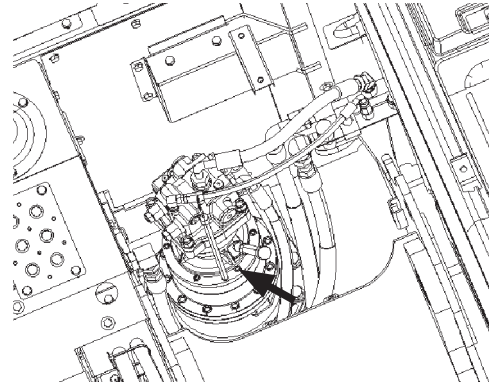

ZX135US-6

MDCN-07-018

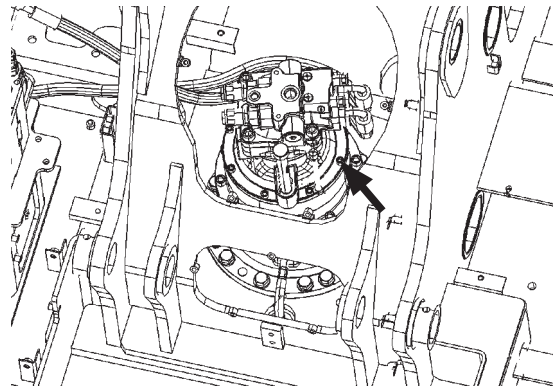

ZX225USLC-6

MDCN-07-069

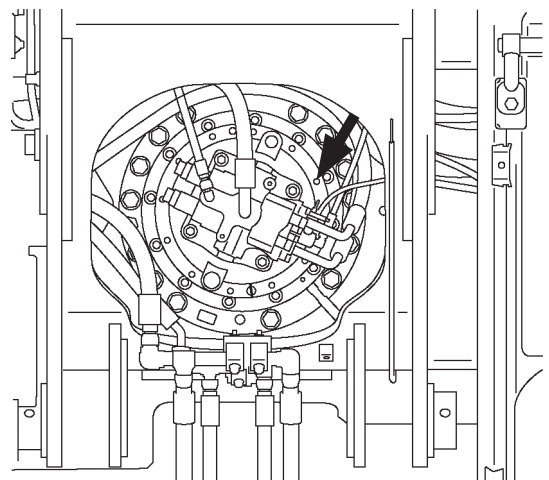

ZX345USLC-6

MDD5-07-026



## MAINTENANCE

### 10. ORS fittings for hydraulic hoses and piping

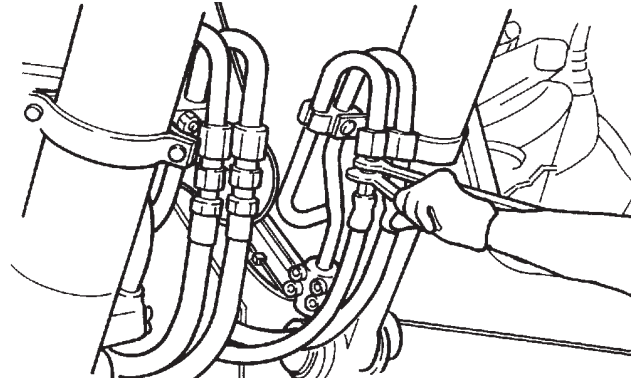

M104-07-079

### 11. Hycolin® tube mounting nuts

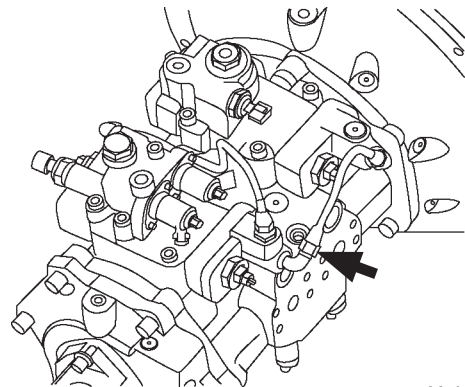

ZX135US-6

M1U1-07-111

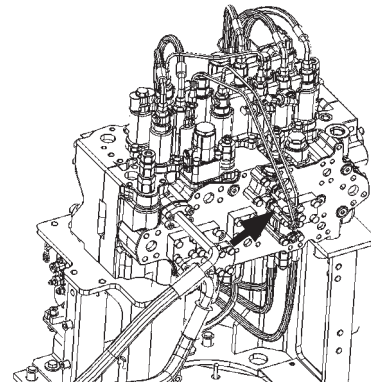

ZX225USLC-6

MDCN-07-071

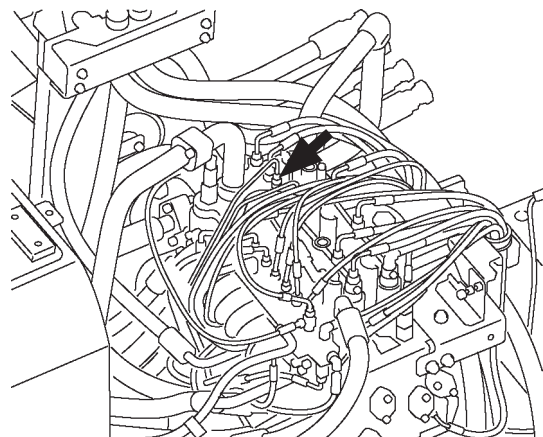

ZX345USLC-6

MDD5-07-027

# MAINTENANCE

## 12. Battery mounting nuts

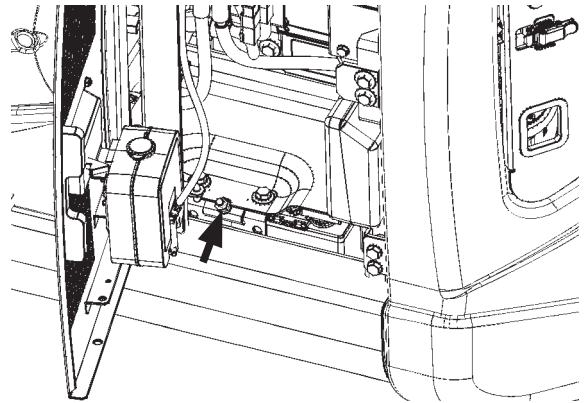

ZX135US-6

MDAT-07-033

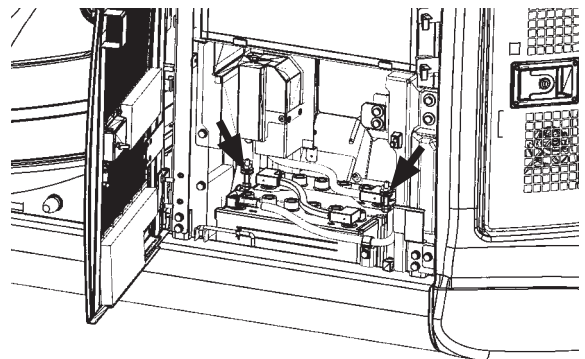

ZX225USLC-6

MDAT-07-034

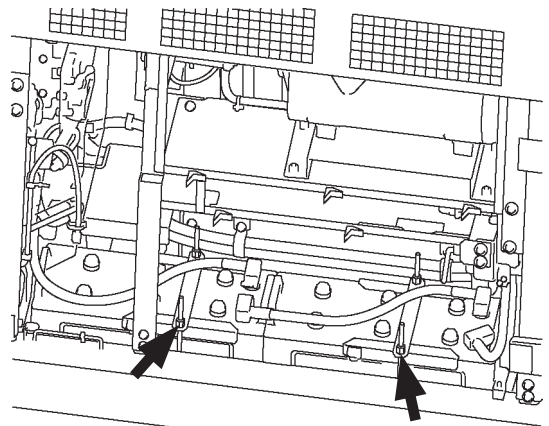

ZX345USLC-6

MDD5-07-028

# MAINTENANCE

## 13. Cab mounting nuts

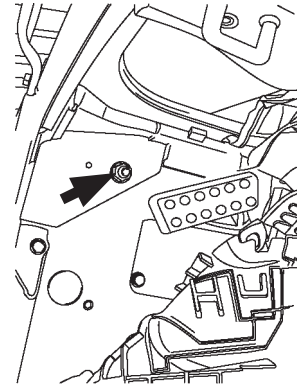

M1U1-07-026

## Cab mounting anchor bolt

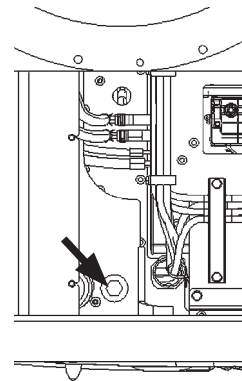

ZX135US-6, 225USLC-6

MDCN-07-073

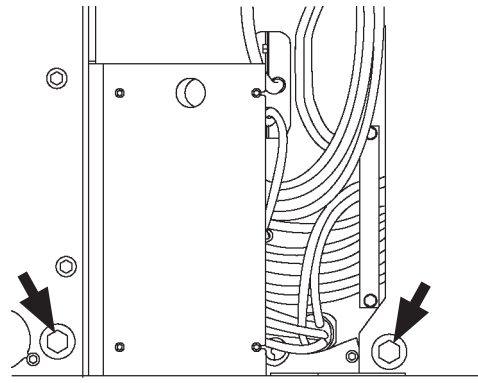

ZX345USLC-6

M1U1-07-054

## Cab cushion rubber mounting bolt

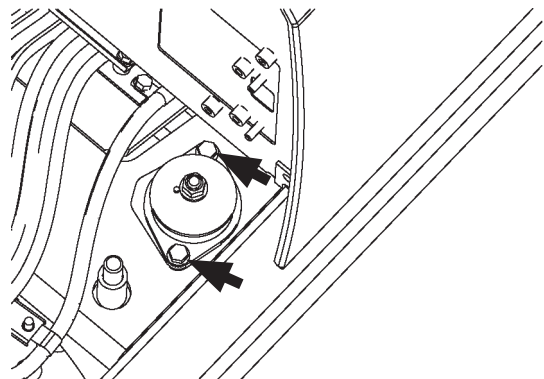

MDC1-07-052

# MAINTENANCE

## 14. Cover mounting bolts

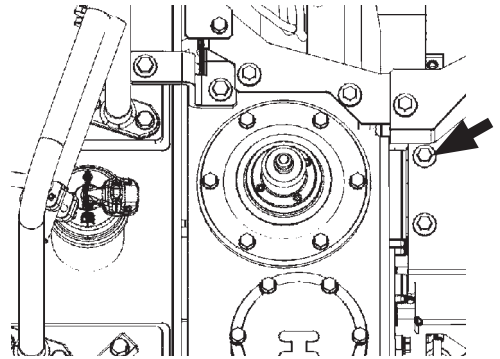

ZX135US-6, 225USLC-6

MDAT-07-035

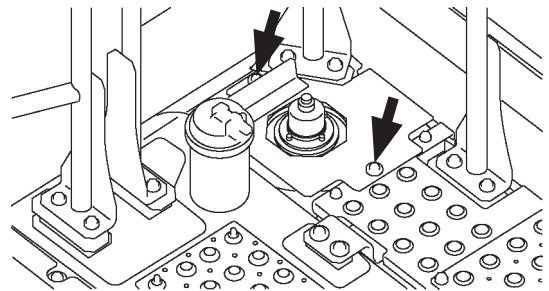

ZX345USLC-6

MDD5-07-011

## 15. Constant torque clamp of low pressure piping

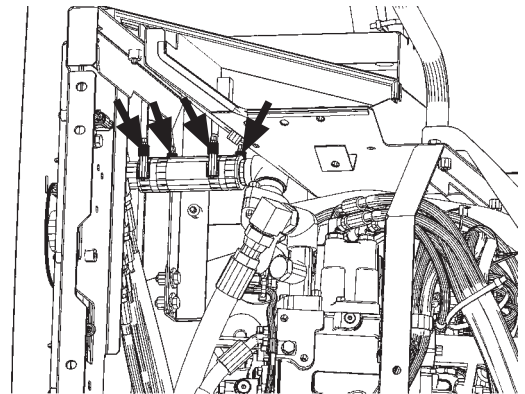

ZX135US-6

MDAT-07-060

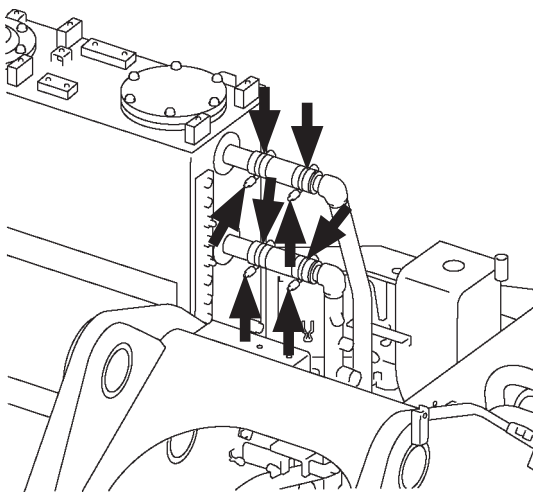

ZX345USLC-6

MDD5-07-029

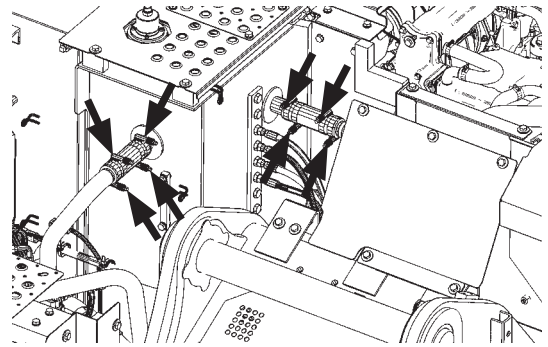

ZX225USLC-6

MDAT-07-078

# MAINTENANCE

## Flexible master coupling of low pressure piping

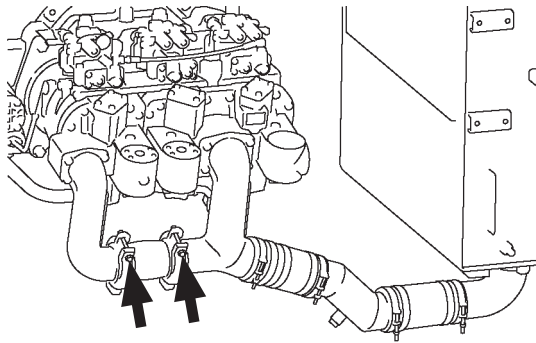

ZX345USLC-6

MDD5-07-030

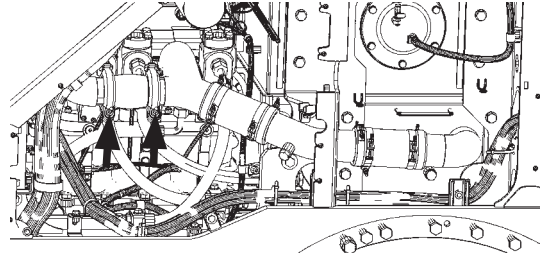

ZX225USLC-6

MDAT-07-062

## T-bolt clamp of low pressure piping

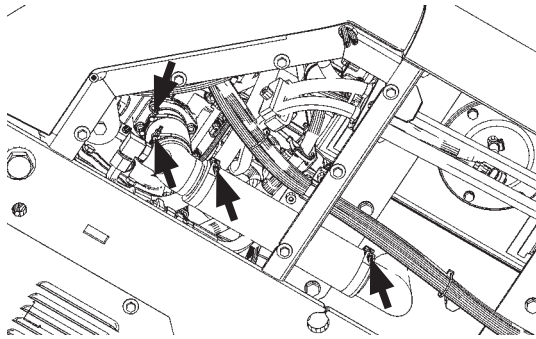

ZX135US-6

MDAT-07-063

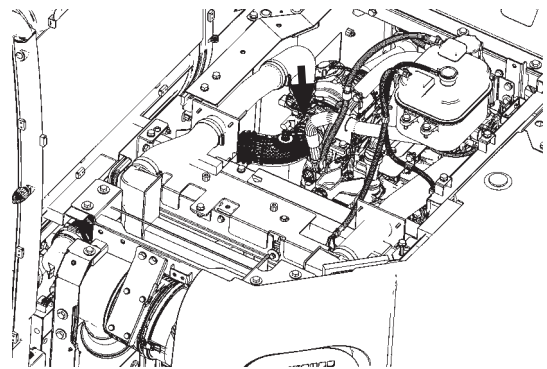

ZX135US-6

MDAT-07-064

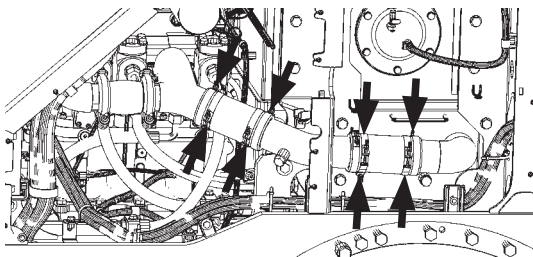

ZX225USLC-6

MDAT-07-062

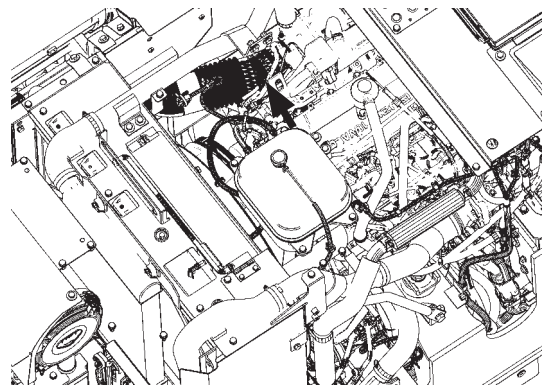

ZX225USLC-6

MDAT-07-065

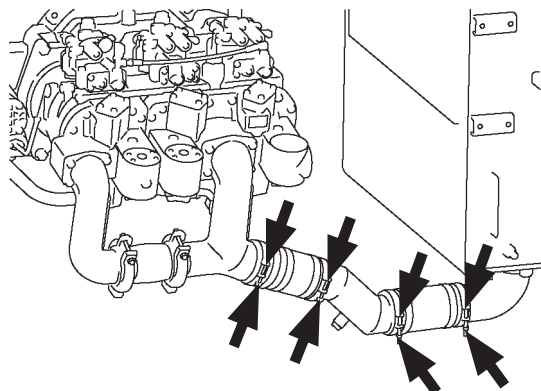

ZX345USLC-6

MDD5-07-030



# MAINTENANCE

Jubilee® clamp of low pressure piping

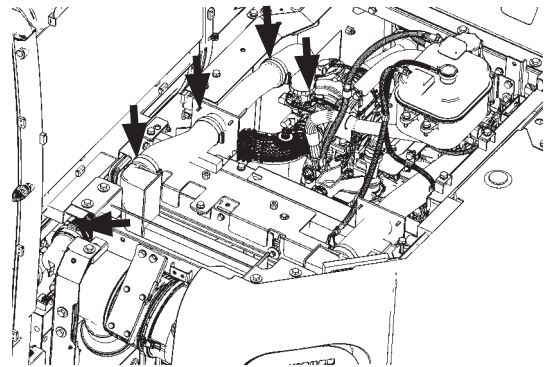

MDAT-07-064

ZX135US-6

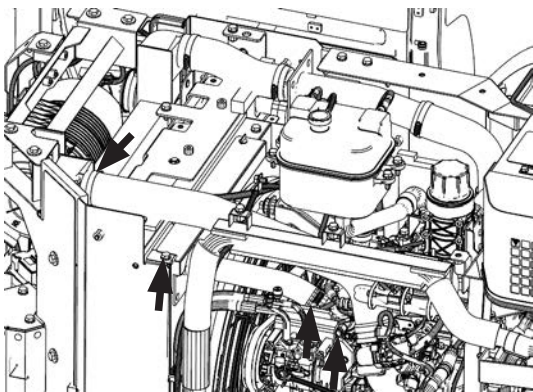

ZX135US-6

MDAT-07-067

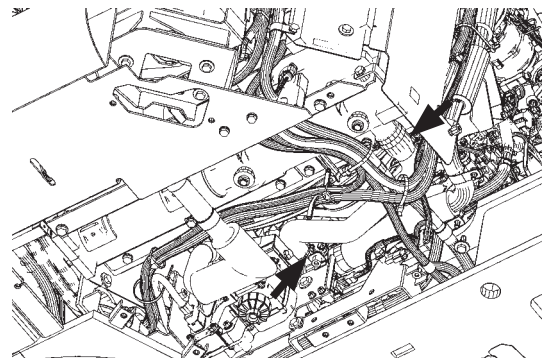

ZX135US-6

MDAT-07-068

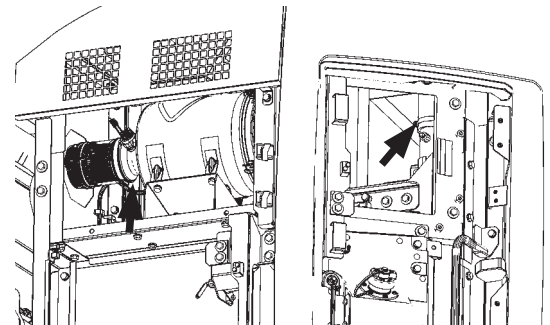

ZX225USLC-6

MDAT-07-069

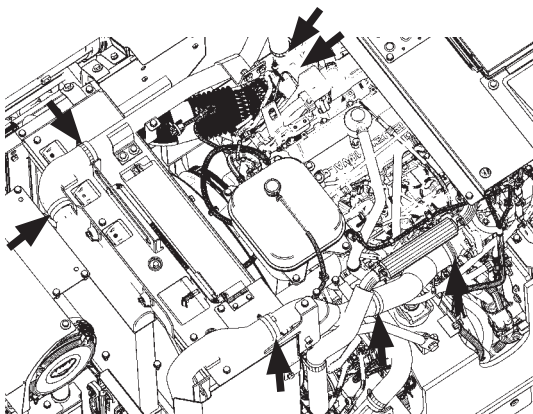

ZX225USLC-6

MDAT-07-065

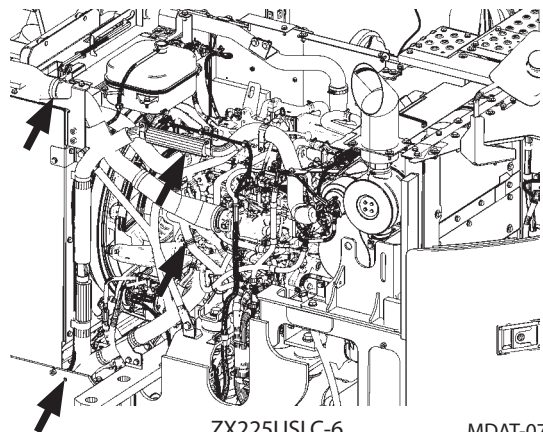

ZX225USLC-6

MDAT-07-061

## MAINTENANCE

### 16. Swing bearing mounting bolts

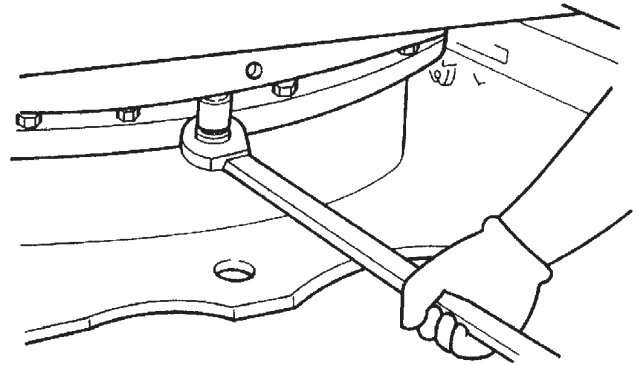

Upperstructure Side

M107-07-088

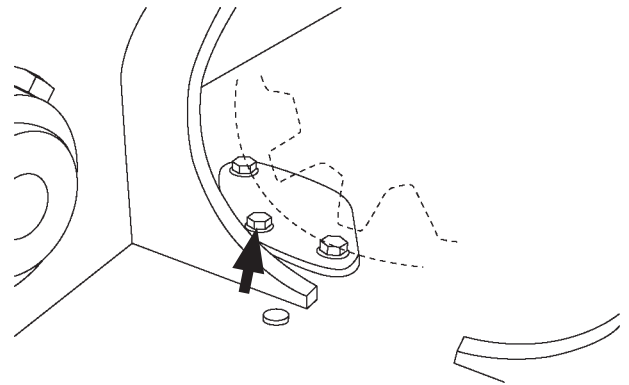

Undercarriage Side

ZX135US-6

M1U1-07-113

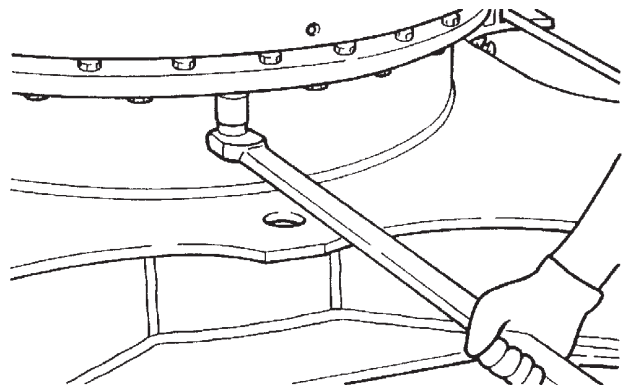

Undercarriage Side

ZX225USLC-6, 345USLC-6

M107-07-089

## MAINTENANCE

---

### 17. Travel device mounting bolts

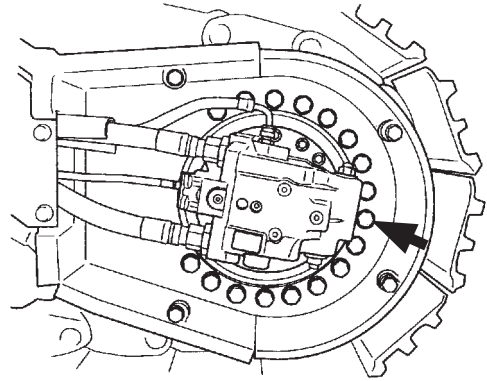

M164-07-005

### Travel reduction gear cover mounting bolts

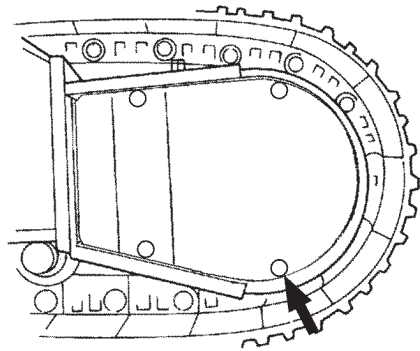

MDFY-07-035-1

### Sprocket mounting bolts

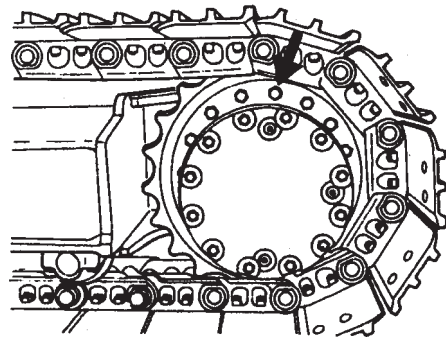

M154-07-050

### 18. Upper roller mounting bolts

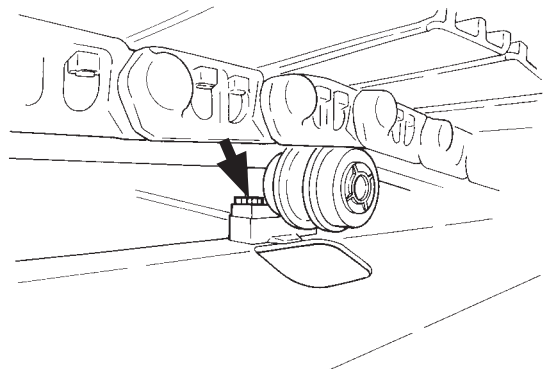

M157-07-224



## MAINTENANCE

---

### 19. Lower roller mounting bolts

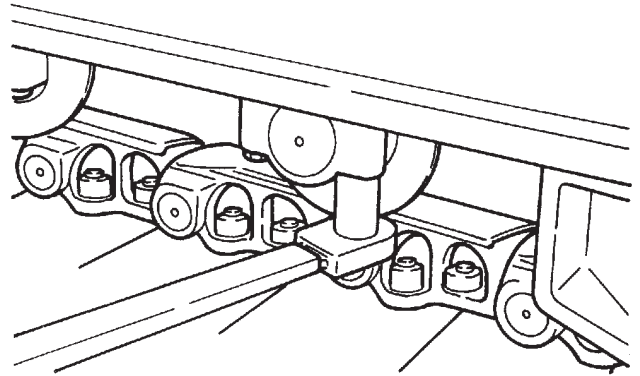

M107-07-092

### 20. Track shoe mounting bolts

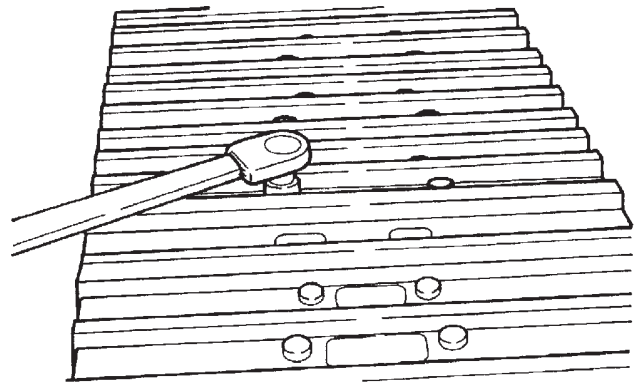

M107-07-093

# MAINTENANCE

## 21. Track guard mounting bolts

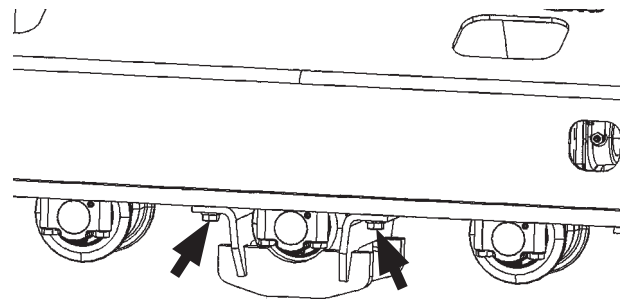

MDAA-07-058

## 22. Aftertreatment device mounting bolts

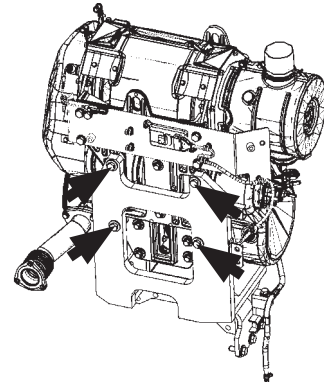

Back plate  
ZX135US-6

MDC1-07-075

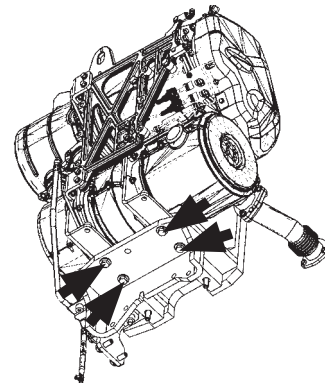

Base plate  
ZX135US-6

MDC1-07-076

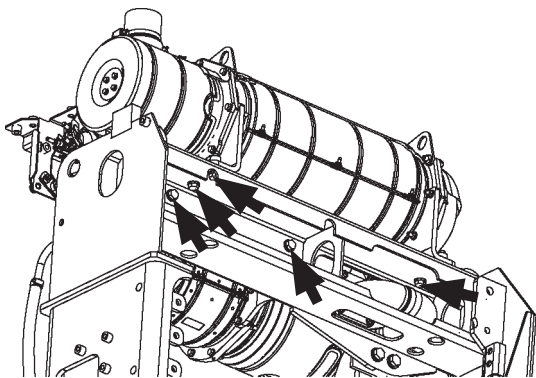

ZX345USLC-6

MDC1-07-049

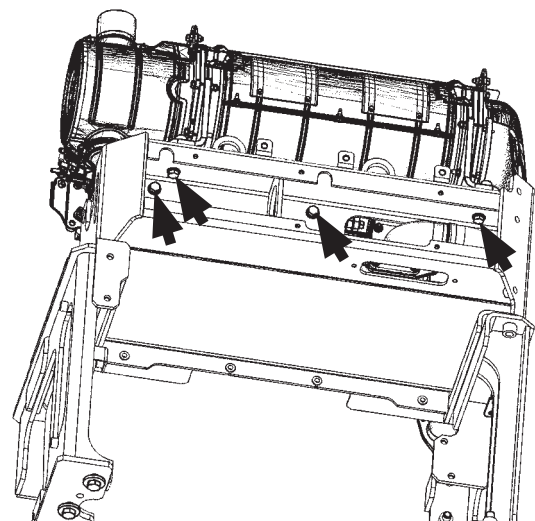

ZX225USLC-6

MDAT-07-037

# MAINTENANCE

## 23. DEF/AdBlue® tank bracket mounting bolts

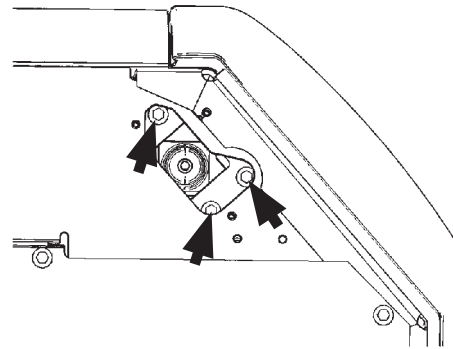

ZX135US-6

MDAT-07-038

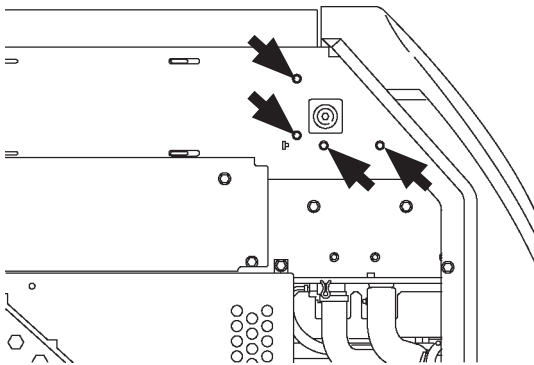

ZX345USLC-6

MDD5-07-032

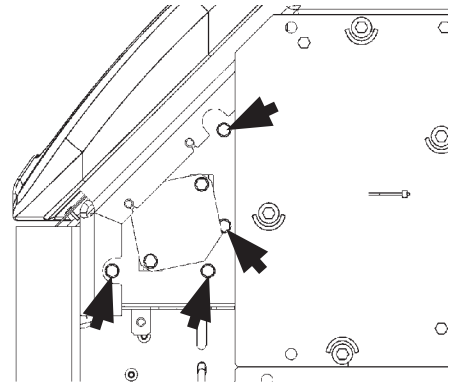

ZX225USLC-6

MDAT-07-039

## 24. Platform handrail mounting bolt

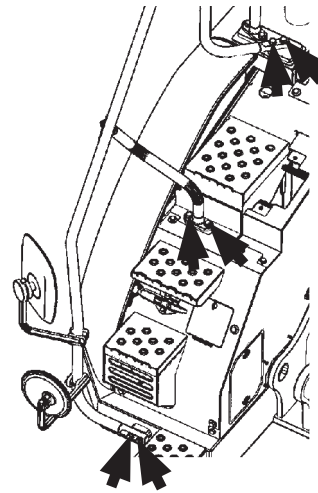

ZX135US-6

MDAT-07-040

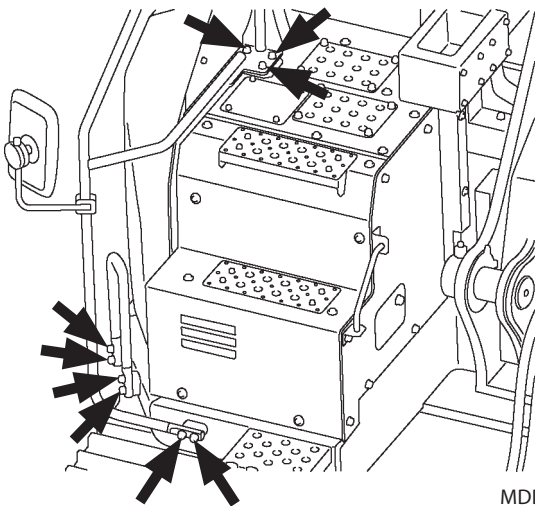

ZX345USLC-6

MDD5-07-033

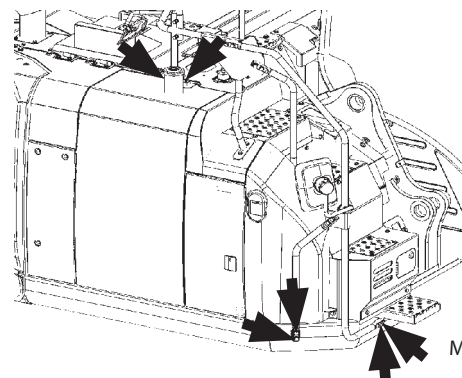

ZX225USLC-6

MDAT-07-041

## MAINTENANCE

### 25. Body top handrail mounting bolt

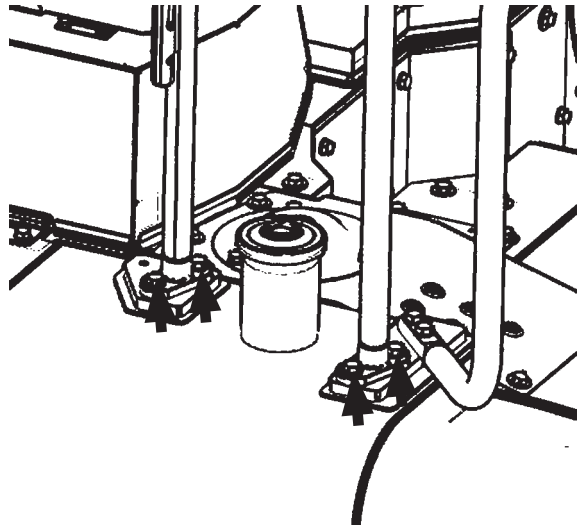

ZX135US-6

MDAT-07-042

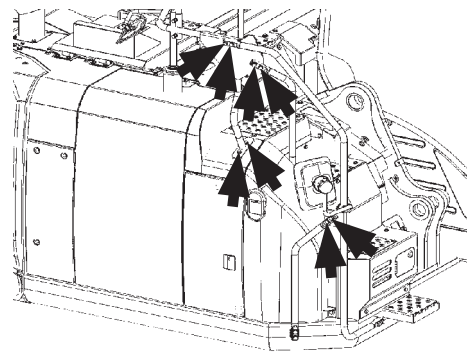

ZX225USLC-6

MDAT-07-041

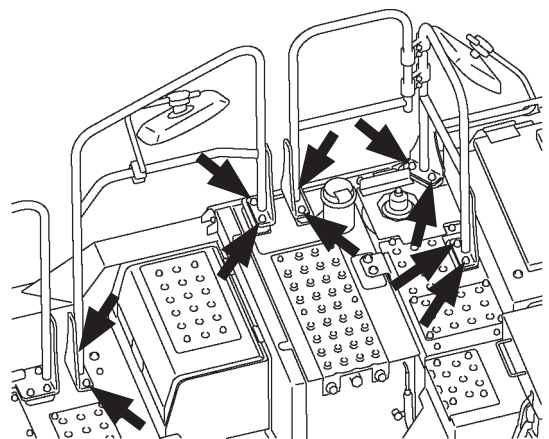

ZX345USLC-6

MDD5-07-034

## MAINTENANCE

---

### 26. Cab top handrail mounting bolt

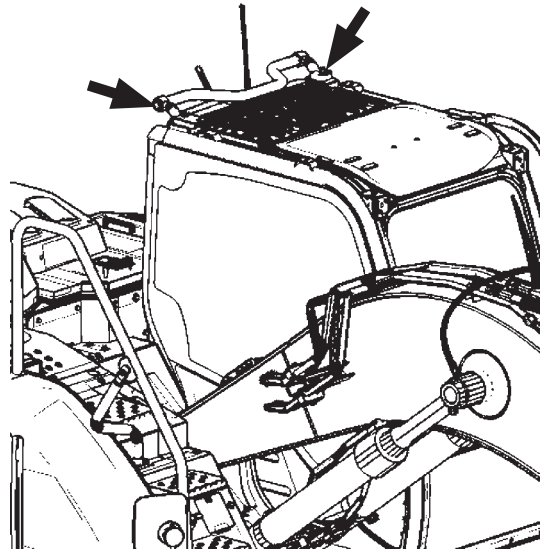

MDAT-07-080

ZX135US-6

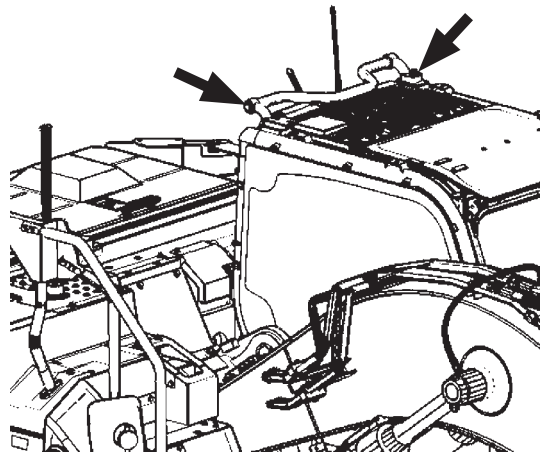

MDAT-07-081

ZX225USLC-6

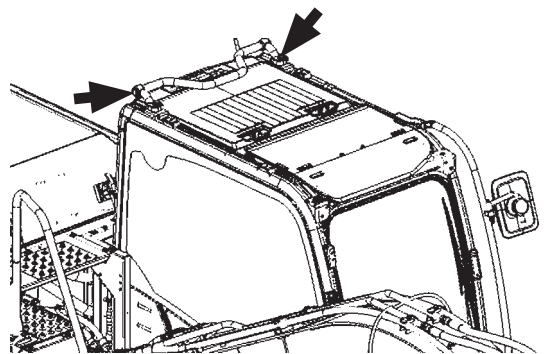

ZX345USLC-6

MDC1-07-077

# MAINTENANCE

## 27. Front pin-retaining bolt

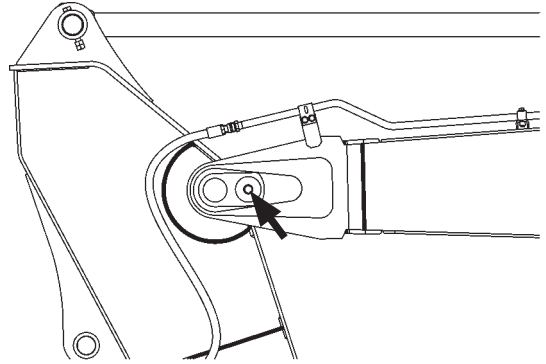

MDCS-07-004

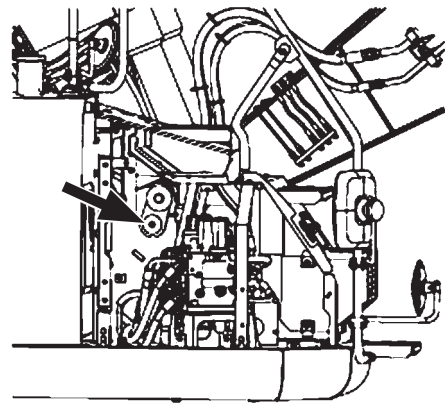

MDAT-07-082

ZX135US-6

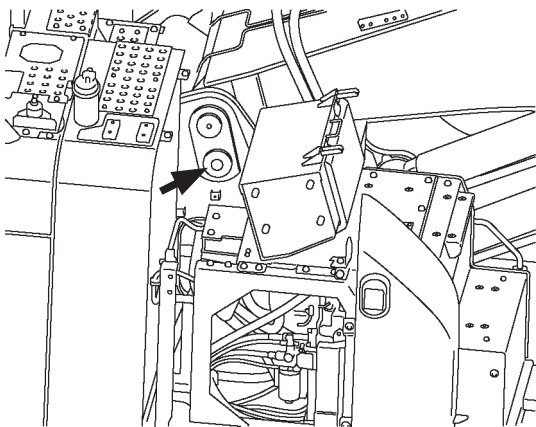

ZX345USLC-6

MDD5-07-035

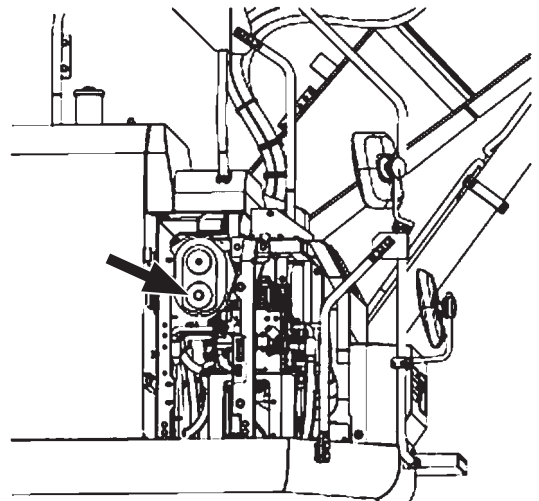

MDAT-07-083

ZX225USLC-6

## MAINTENANCE

---

Boom top, Arm cylinder bottom and rod pin-retaining bolt

(There are three bolts on the boom top.)

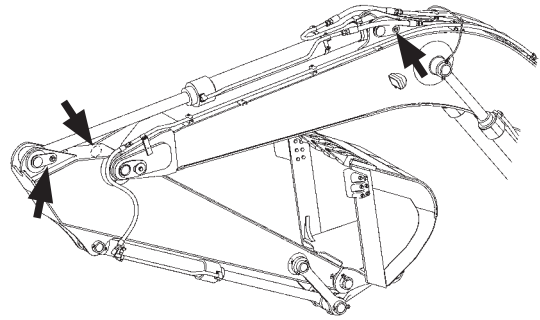

ZX345USLC-6

MDCA-07-001

## MAINTENANCE

### J. Aftertreatment Device

- 1 Check and Clean Aftertreatment Device  
--- as required

#### IMPORTANT:

- Check and clean flammable materials on the area around the Aftertreatment device.
- Condensation for dew may blow out from exhaust outlet (1) of the aftertreatment device and black deposition may be observed; it is not a malfunction.

Do not disassemble the base machine support parts and sensors.

When the machine is operated in dusty areas, refer to the page 9-1 "Maintenance Under Special Environmental Conditions".

Open the engine cover.

Check the NOx sensor, harnesses of exhaust temperature sensors and dosing module for abnormality.

Securely close the engine cover.

Clean it if necessary.

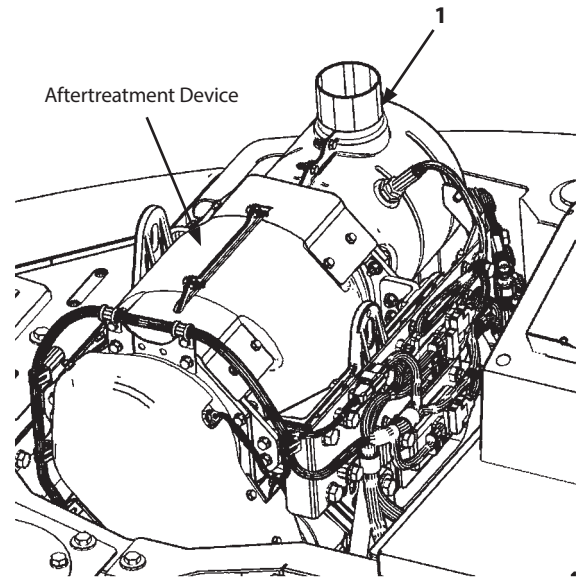

ZX135US-6, 225USLC-6

MDAT-07-043

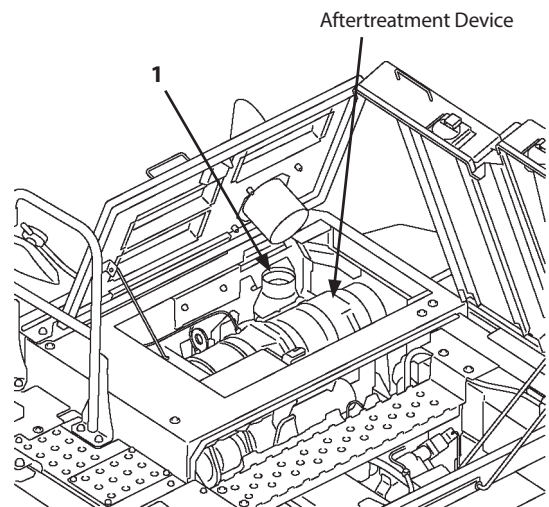

ZX345USLC-6

MDD5-07-036



## MAINTENANCE

---

### K. Urea SCR System

 **WARNING: Fill specified DEF/AdBlue® into the DEF/AdBlue® tank.**

**If improper DEF/AdBlue® is refilled, fire or system failure may result. If improper liquid is refilled in the DEF/AdBlue® tank, consult your authorized dealer for check or repair.**

#### Specified DEF/AdBlue®

Refill DEF/AdBlue® which meets Japanese Industrial Standards (JIS K2247), International Organization for Standardization (ISO 22241) or Deutsche Industrie Normen (DIN 70070). If improper liquid (diesel oil, kerosene or gasoline) is refilled in the DEF/AdBlue® tank, fire or system failure may result. The specified DEF/AdBlue® is colorless and odorless solution (urea 32.5%, water 67.5%) which begins to freeze at -11 °C. When storing unused DEF/AdBlue®, it is recommended to store it within the temperature range of -10 to 30 °C. It deteriorates down more readily at 40 °C.

In some cases, specified area solution is referred to by one or more of these names:

- Aqueous Urea Solution 32
- AUS 32
- NO<sub>x</sub> Reduction Agent
- Catalyst Solution

## MAINTENANCE

---

### CAUTION:

- DEF/AdBlue® is colorless and harmless solution. It is harmless when contacting with the body, however, it may cause skin to become inflamed depending on the constitution of the individual. Flush DEF/AdBlue® with clean water when it contacts on the skin.
- If you swallow DEF/AdBlue® by mistake, drink 1 or 2 cups of water or milk and seek immediate medical attention.
- If DEF/AdBlue® is accidentally splashed into eyes, flush with water for 15 minutes or longer and get emergency medical attention.

### IMPORTANT:

- Use dedicated container recommended by the business entity who is handling DEF/AdBlue® to store DEF/AdBlue®. Do not use general container, a container used for other purpose and contaminated container because the quality of DEF/AdBlue® deteriorates.
- The DEF/AdBlue® is non-combustible, however, move DEF/AdBlue® to a safe place when fire occurs.
- Wash out spilled DEF/AdBlue® with clean water.
- Seal the container and store it in a well ventilated place. If DEF/AdBlue® freezes, the quality does not change just after freezing.
- As long as sealed by an airtight stopper, unless water evaporates DEF/AdBlue® will not deteriorate within the guarantee period.
- Do not pour waste DEF/AdBlue® and its containers onto the ground, and do not allow waste to flow into rivers and/or lakes. When disposing DEF/AdBlue®, make sure to let authorized industrial waste disposal contractor dispose of it appropriately.

## MAINTENANCE

### 1 Check DEF/AdBlue® ---daily

Park the machine on a level surface. Lower the bucket to the ground. Check the DEF/AdBlue® level with DEF/AdBlue® gauge (1).

If necessary, stop the engine and add DEF/AdBlue®.

#### Refill DEF/AdBlue®

#### **CAUTION:**

- Refill DEF/AdBlue® which meets Japanese Industrial Standards (JIS K2247), International Organization for Standardization (ISO 22241) or Deutsche Industrie Normen (DIN 70070) in DEF/AdBlue® tank (2). If low density DEF/AdBlue® is refilled, alarm will be generated, restricting machine operation. Do not dilute DEF/AdBlue® with water.
- Do not add any additives to the specified DEF/AdBlue®. Similarly, do not use DEF/AdBlue® that already has additives in it. Doing so may cause damage to the machine.
- Wear safety equipment such as safety glasses or goggles, rubber gloves appropriate to the job. Wash DEF/AdBlue® with clean water when it contacts on the skin. If DEF/AdBlue® is accidentally splashed into eyes, flush with water for 15 minutes or longer and get emergency medical attention.

1. Park the machine according to the instruction on "Preparations for Inspection and Maintenance" (7-8).
2. DEF/AdBlue® tank (2) is located in the cover at right front of the machine. Open the cover with the key. Holding the handle on the access cover, raise the cover until the cover is secured with catch. Prior to starting to refill, make sure no contaminants, such as sand or dust, are on the DEF/AdBlue® refill container or the port of the DEF/AdBlue® device.
3. Clean dust and mud around the filler port of DEF/AdBlue® tank with clean cloth.

Model	DEF/AdBlue® Tank Capacity
ZX135US-6	13 L
ZX225USLC-6, 345USLC-6	16 L

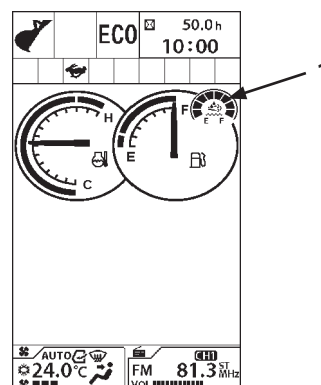

MDC1-01-001

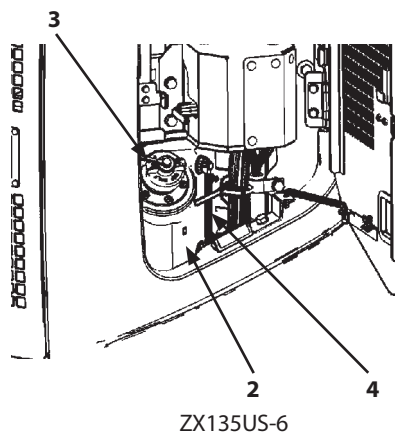

ZX135US-6

MDAT-07-044

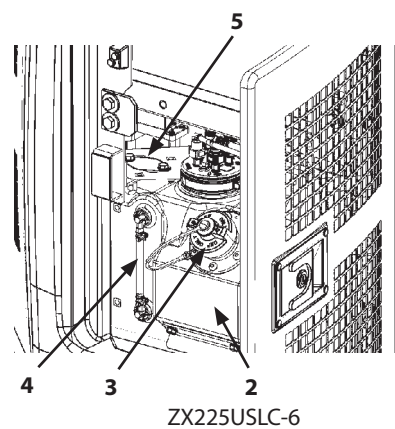

ZX225USLC-6

MDAT-07-045

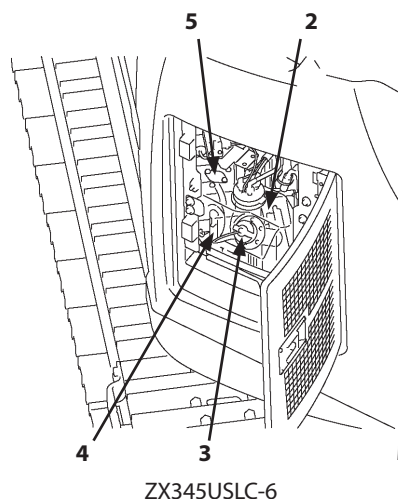

ZX345USLC-6

MDD5-07-037

## MAINTENANCE

4. Remove cap (3) from DEF/AdBlue® tank (2) and refill DEF/AdBlue®. Be sure to stop refilling before the “F” line by checking the level gauge (4) float.

### IMPORTANT:

- **Make sure the containers and equipment used for refilling are free of contaminants, such as sand, mud and dirt. If any contaminants are present, either rinse them off with soft water or wipe them off with a clean cloth before refilling.**
- **Take care not to allow dust and/or water to enter the DEF/AdBlue® tank when refilling.**
- **Put cap (3) of DEF/AdBlue® tank (2) on the cap holder (5) to prevent the cap from contamination.**
- **If DEF/AdBlue® is filled above the “F” line, the system may be damaged during operation or tank (2) may be broken when frozen.**

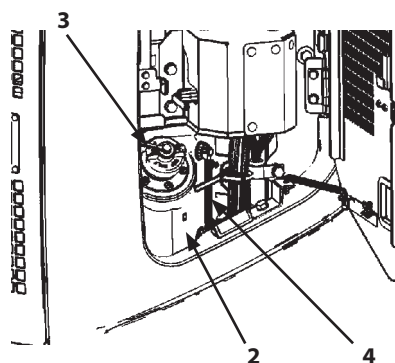

ZX135US-6

MDAT-07-044

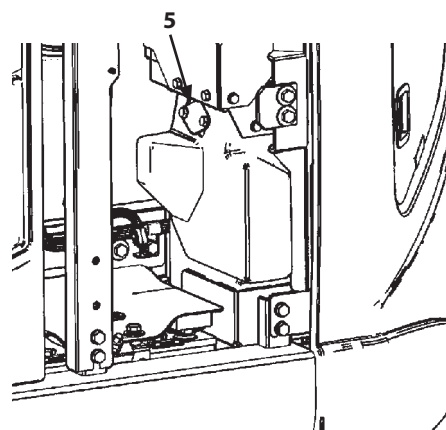

ZX135US-6

MDAT-07-046

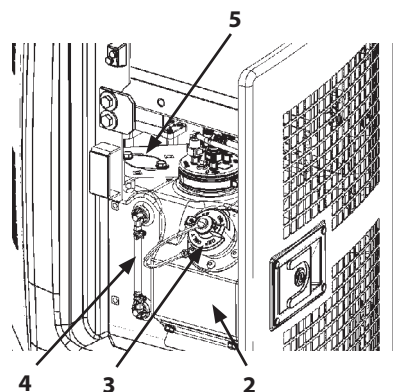

ZX225USLC-6

MDAT-07-045

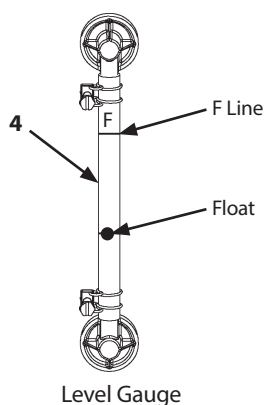

MDC1-07-053

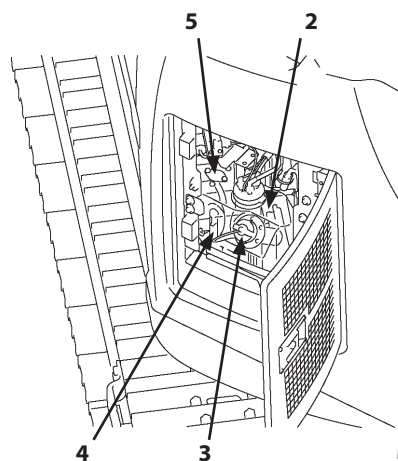

ZX345USLC-6

MDD5-07-037

## MAINTENANCE

5. Install cap (3) after refilling DEF/AdBlue®. Close the tank cover and lock it with the key.

### IMPORTANT:

- **Do not get on top of DEF/AdBlue® tank (2) or sensors and piping on the tank. Failure to do so may damage the machine.**
- **If it becomes necessary to refill DEF/AdBlue® when cap (3) can not be removed due to freezing, use emergency filler port (5).**
- **White deposits may be observed when DEF/AdBlue® is dried naturally; it is normal. Wash out DEF/AdBlue® deposits with soft water. Never use a high pressure washer.**

### NOTE:

- *Wipe spilled DEF/AdBlue® and wash spilled area with plenty of water.*
- *The sound of flowing water may be heard from the tank after the engine stops. It is the sound of returning DEF/AdBlue® from piping to the tank, not a malfunction.*
- *DEF/AdBlue® will freeze at low temperature, and deteriorate (ammonification) at high temperature. Store DEF/AdBlue® at temperature between -10 and 40°C.*
- *Use dedicated container (purchased container) to store or carry DEF/AdBlue®. Alternatively use a polyethylene resin tank, or stainless steel tank.*

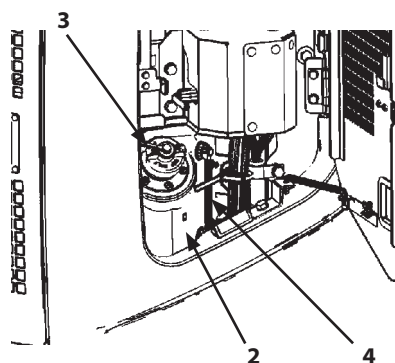

ZX135US-6

MDAT-07-044

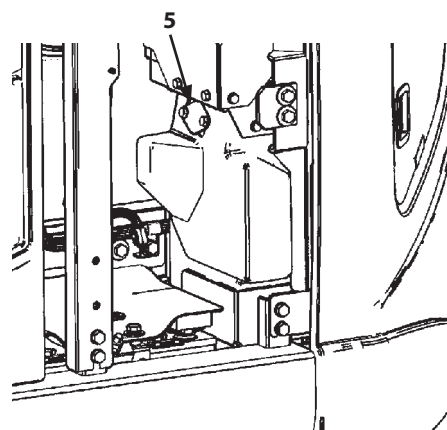

ZX135US-6

MDAT-07-046

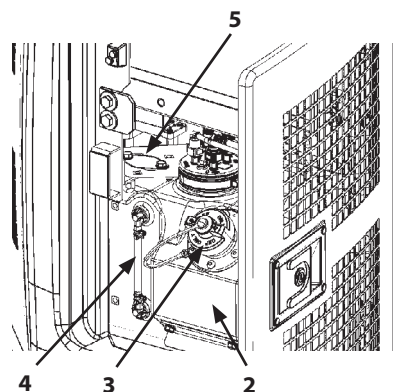

ZX225USLC-6

MDAT-07-045

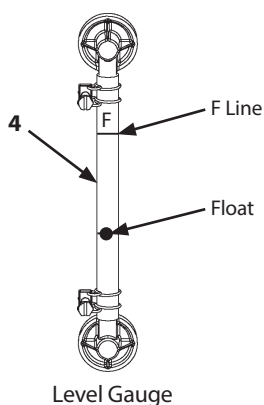

Level Gauge

MDC1-07-053

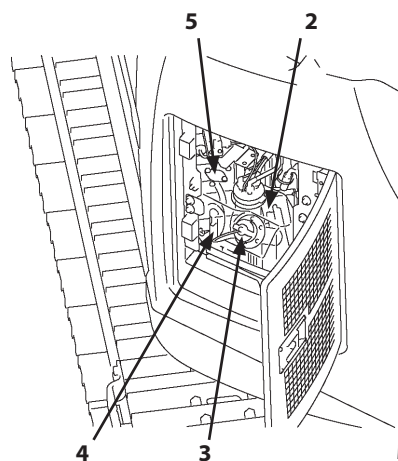

ZX345USLC-6

MDD5-07-037

## MAINTENANCE

### Clean Filler Port Strainer

Strainer (1) is provided on the filler port of the DEF/AdBlue® tank. Clean strainer (1) if dirt or dust is observed.

**CAUTION:** Wear safety equipment such as safety glasses or goggles, rubber gloves appropriate to the job. Wash DEF/AdBlue® with clean water when it contacts with the skin. If DEF/AdBlue® is accidentally splashed into eyes, flush with water for 15 minutes or longer and get emergency medical attention.

**IMPORTANT:** Take care not to allow dust to contaminate the area when carrying out the work.

1. Remove strainer (1) from the filler port of the DEF/AdBlue® tank.
2. Clean strainer (1) with compressed air pressure (lower than 0.2 MPa (2 kgf/cm<sup>2</sup>)) or tap water.
3. Install strainer (1) on the filler port of the DEF/AdBlue® tank.

**NOTE:** If extendable filler neck (2) is used, clean strainer (3).

**IMPORTANT:** If DEF/AdBlue® overflows when supplying water, even if clean strainer (1), (3), contact your authorized dealer.

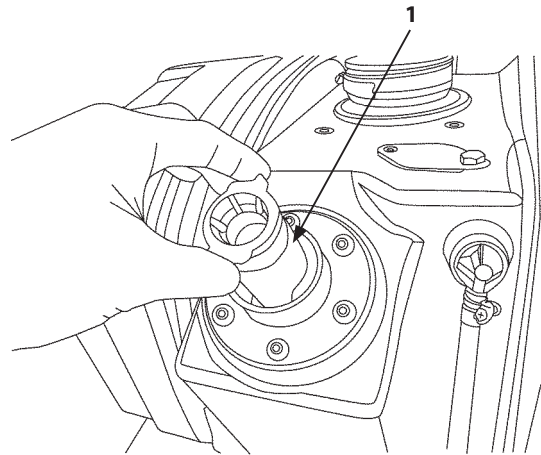

MDC1-07-032

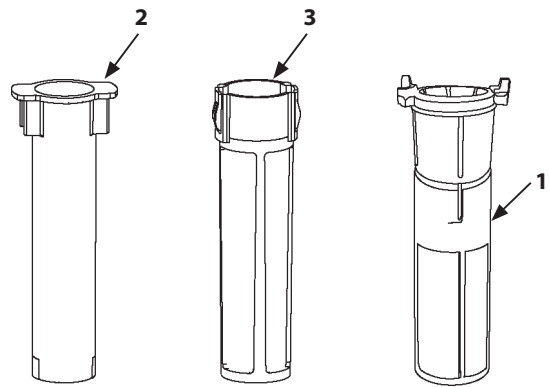

MJAG-07-070

MJAG-07-071

MJAG-07-072

## MAINTENANCE

### Change DEF/AdBlue®

**⚠ CAUTION:** Wear safety equipment such as safety glasses or goggles, rubber gloves appropriate to the job. Wash DEF/AdBlue® with clean water when it contacts with the skin. If DEF/AdBlue® is accidentally splashed into eyes, flush with water for 15 minutes or longer and get emergency medical attention.

**IMPORTANT:** When contaminated or deteriorated DEF/AdBlue® is used, malfunction may result. Change DEF/AdBlue® periodically to keep cleanliness in the tank.

1. Remove bolts (1) and cover (2).
2. Place a 70 liter or larger capacity container under drain plug (3).
3. Slowly loosen drain plug (3) to drain DEF/AdBlue®.
4. Tighten drain plug (3) after draining DEF/AdBlue®.

Wrench size: 13 mm

Tightening torque: 19.5 N·m (1.95 kgf·m)

5. Fix cover (2) with bolts (1).

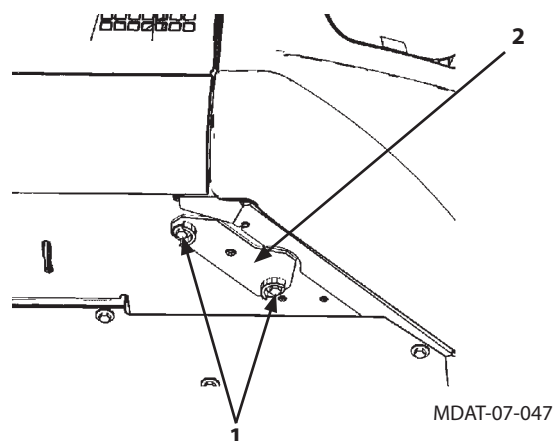

ZX135US-6

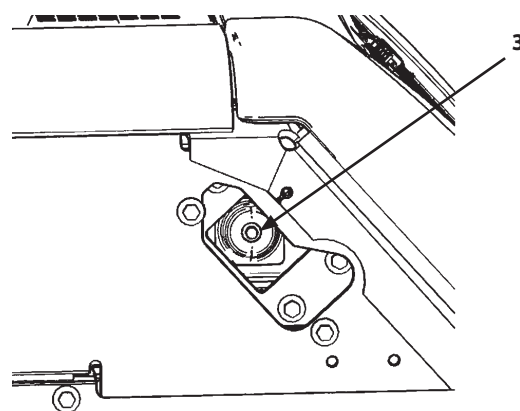

ZX135US-6

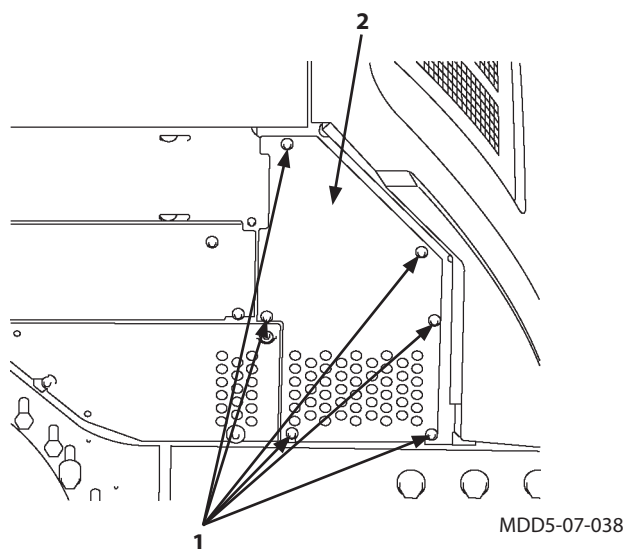

ZX345USLC-6

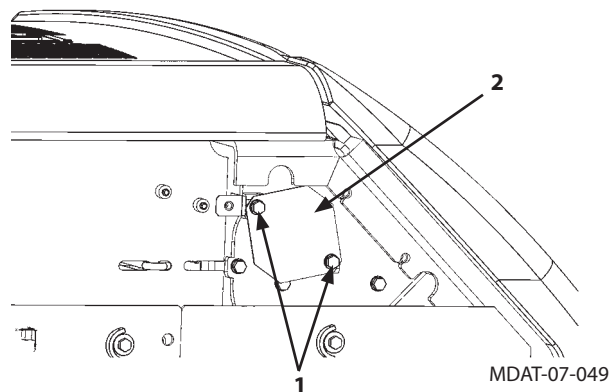

ZX225USLC-6

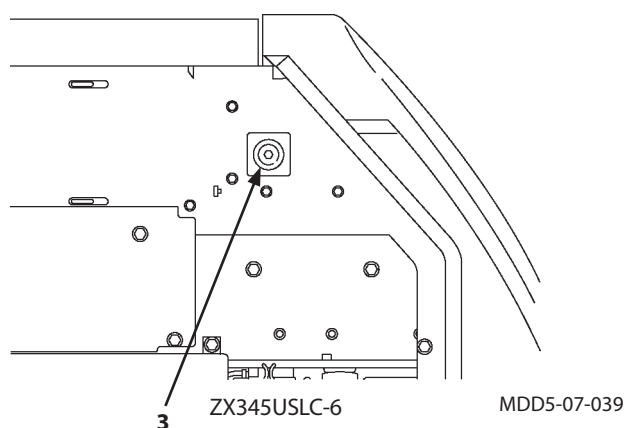

ZX345USLC-6

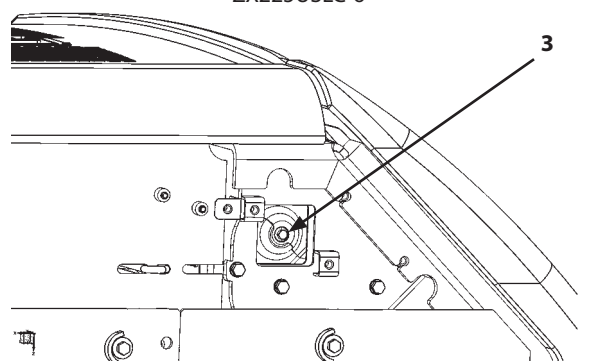

ZX225USLC-6

## MAINTENANCE

### 2 Replace DEF/AdBlue® Supply Module Main Filter --- every 4500 hours

A filter (4) is mounted in the DEF/AdBlue® pump. Periodically replace filter (4).

**CAUTION:** Wear safety equipment such as safety glasses or goggles, rubber gloves appropriate to the job. Wash DEF/AdBlue® with clean water when it contacts with the skin. If DEF/AdBlue® is accidentally splashed into eyes, flush with water for 15 minutes or longer and get emergency medical attention.

#### IMPORTANT:

- Take care not to allow dirt and/or water to enter the DEF/AdBlue® tank while replacing filter (4).
- Check for leaks around the mounting position after replacement.
- White deposition may be observed when DEF/AdBlue® is dried naturally; it is normal. Wash out DEF/AdBlue® deposition with clean water. Never use a high pressure washer.

1. Park the machine according to the instruction on Preparations for Inspection and Maintenance (7-8).

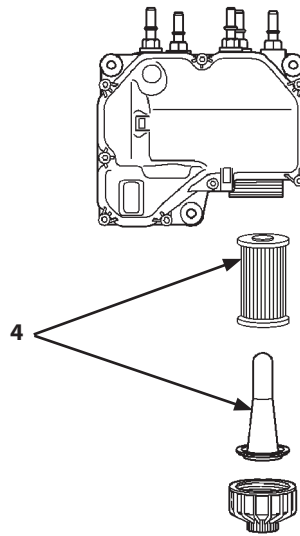

MLAD-07-037



## MAINTENANCE

 **NOTE:** The DEF/AdBlue® pump is located bottom of the machine, near the engine.

2. Remove bolts (1) and cover (2).
3. Remove cap (3) from the DEF/AdBlue® pump by using a 27 mm bihexagon wrench.
4. Pull out filter (4) inside the pump. As it is tightly mounted, it can not be pulled by hands. Use tools such as a pliers. Replace filter (4) assembly when replacing filter (4) of DEF/AdBlue® supply module.
5. Install new filter (4), and tighten cap (3) with 20±5 N·m (2.0±0.5 kgf·m) torque.
6. Fix cover (2) with bolts (1).

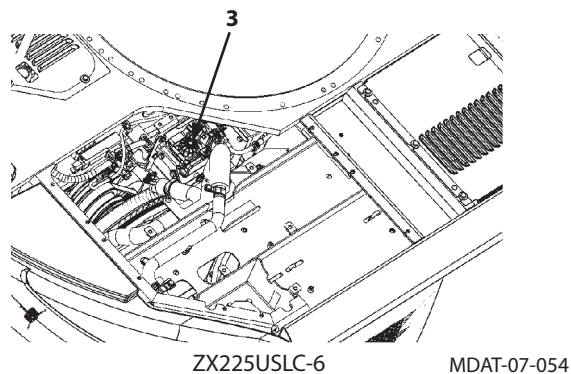
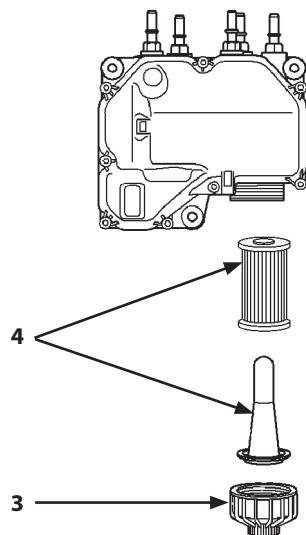
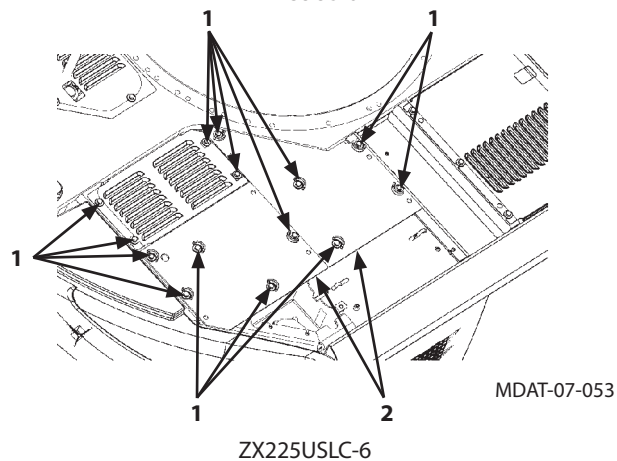
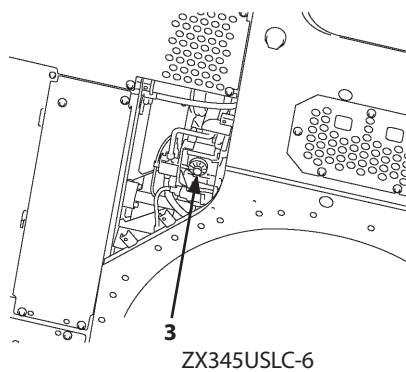
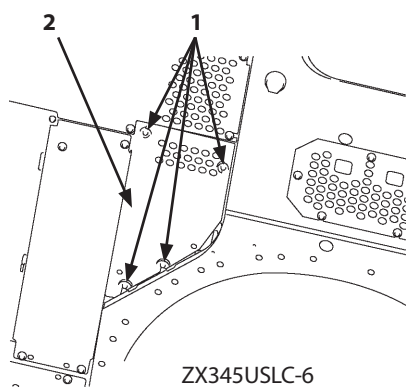
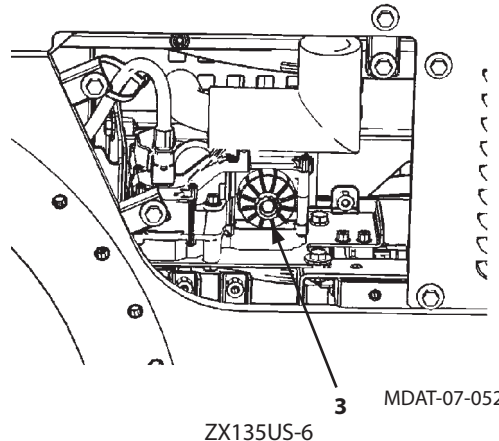
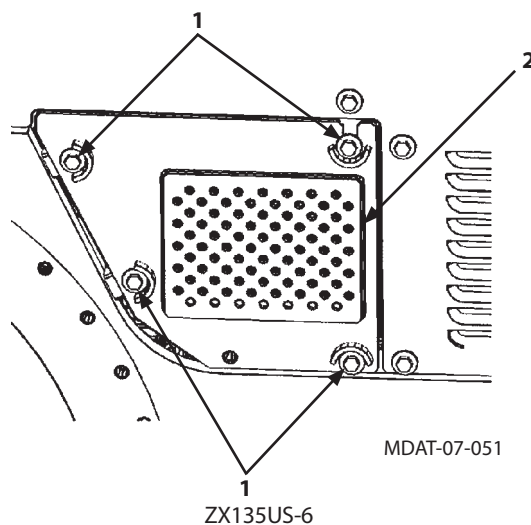

## MAINTENANCE

---

- 3** **Replace DEF/AdBlue® Tank Water Supply Inlet Filter**  
--- every 4500 hours or if DEF/AdBlue® overflows  
when supplying water

**IMPORTANT:** Replace the filter without cleaning. Reusing after cleaning may cause a malfunction.

The filter inside the water supply inlet of the DEF/AdBlue® tank must be replaced periodically. Consult your authorized dealer for replacement.

## MAINTENANCE

---

- 4** Replace the DEF/AdBlue® back flow line filter  
--- every 4500 hours

**IMPORTANT:** Replace the filter without cleaning. Reusing after cleaning may cause a malfunction.

There is a circuit returning DEF/AdBlue® from the DEF/AdBlue® supply module to the DEF/AdBlue® tank. This circuit is equipped with a back flow filter. The back flow filter must be replaced periodically. When it is time to replace it, contact your nearest authorized dealer.

# MAINTENANCE

## L. Aerial Angle

### 1 Daily Checks of Aerial Angle Camera Images --- daily (Before Starting the Engine)

#### Method of Checking

1. Turn key switch (1) to the ON position.
2. Press screen changeover switch (3) and make sure the image on main monitor (2) changes.
3. Bring up the image around the machine on main monitor (2) and make sure that all the camera images are depicted without any problems in terms of visibility.

#### ⚠ WARNING:

- If an image is difficult to see, clean the camera(s) and/or monitor to make the image clearer. Always ensure good footing when cleaning the cameras.
- If the visibility fails to improve after cleaning the camera lenses and monitor, or if there is a problem like a missing image, consult your authorized dealer.

 NOTE: The surfaces of monitor display (2) and the camera lenses are made of plastic. When cleaning them, use a clean, water-dampened cloth and wipe them gently. Never use an organic solvent.

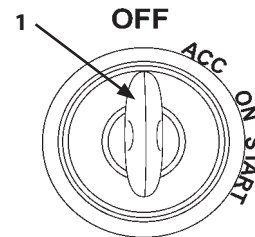

MDCD-01-030

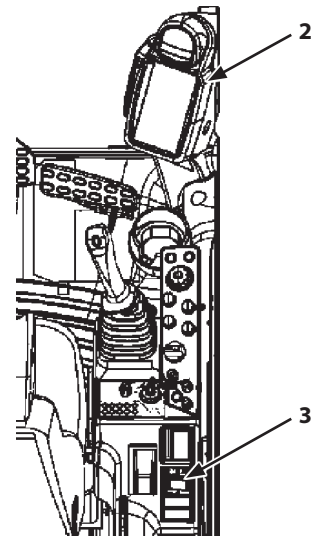

MDC1-01-573

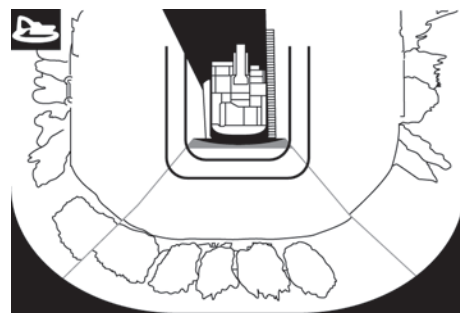

Image Around Machine

MDC1-01-584

## MAINTENANCE

### 2 Checking Aerial Angle Camera Images --- Whenever work that affects the camera installation position is done

**IMPORTANT:** It may be necessary to reconfigure the camera composition if work is done that affects camera installation position (such as removing/installing camera brackets, counterweights or replacing a camera). Perform the following inspections to make sure camera images are displayed properly.

Turn key switch (1) ON and make sure there are no problems in the display of the image around the vehicle, as follows.

#### Preparations for Inspections

1. Choose a location with solid, level ground.
2. Make sure the area around the vehicle is 3 meters wide or so.
3. This work requires either 2 people, one person (the operator) checking the images inside the cab and a pointer (person walking around the machine), or 3 people as needed; the 3rd person conveys instructions from the operator to the pointer.
4. Meet and decide in advance how to work together, such as how to signal.
5. Put the bucket on the ground and put pilot control shut-off lever (2) in the LOCK position.

#### Method of Checking

1. Display the image around the machine.
2. The pointer walks around upperstructure (3) on a line 1 meter away from it.
3. The operator is in the cab and looks at the image on the monitor to make sure the image of the pointer is recognized correctly.

#### **WARNING:**

- If there is a location where the pointer disappears, the camera composition has to be reconfigured. Consult your authorized dealer.

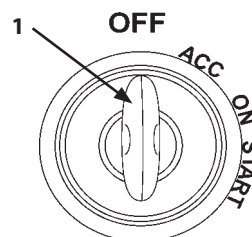

MDCD-01-030

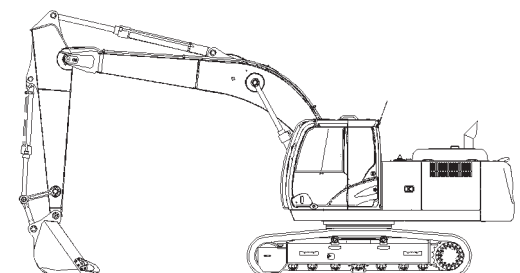

MDCK-OP3-030

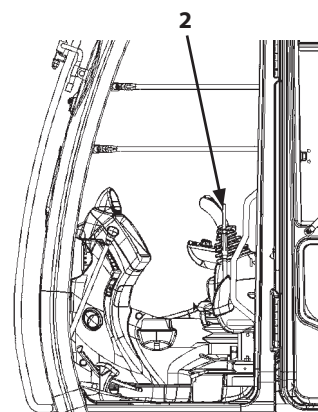

MDCN-01-008

LOCK position

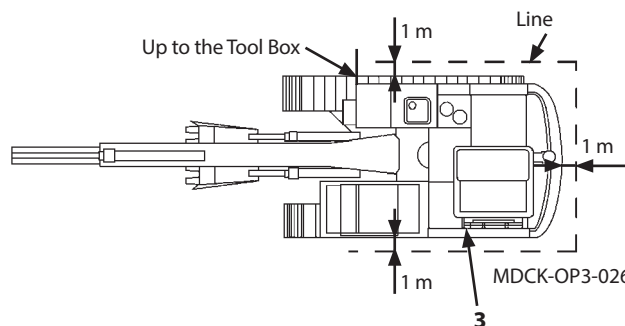

MDCK-OP3-026

## MAINTENANCE UNDER SPECIAL ENVIRONMENTAL CONDITIONS

### Maintenance Under Special Environmental Conditions

Operating Conditions	Precautions for Maintenance
Muddy Soil, Rainy or Snowy Weather	After Operation : Clean the machine and check for cracks, damage, loose or missing bolts and nuts. Lubricate all necessary parts without delay.
Near the Ocean	After Operation : The following salt pollution measures must be taken when the machine is operated at sea or near the coastline. <ol style="list-style-type: none"> <li>(1) After completing the work, extend/retract the hydraulic cylinders several times to form an oil film on the rod surface. Store the machine with cylinders retracted as much as possible.</li> <li>(2) Thoroughly clean the machine with fresh water to wash off salt.</li> <li>(3) To prevent corrosion, perform touch up painting periodically on hose fittings, lubrication piping and inserting position of cover, where sea water is easily collected.</li> <li>(4) During storage of the machine, cover the machine with tarpaulin to prevent sea water from entering into the cab vent. Apply rust prevention oil (example: ANTIRUST P-1300NP-3 JX Nippon Oil &amp; Energy Corporation) onto plated part of the cylinder rods.</li> </ol>
Dusty Atmosphere	Radiator : Clean the radiator to prevent clogging of the radiator core. Engine, Aftertreatment Device : Clean earlier than the normal interval to prevent dust from sticking and accumulating. Inhibit the aftertreatment device regeneration according to the machine operating condition.
Rocky Ground	Tracks : Carefully operate while checking for cracks, damage and loose bolts and nuts. Loosen the tracks a little more than usual. Front Attachment : Standard attachment may be damaged when digging rocky ground. Reinforce the bucket before using it, or use a heavy duty bucket.
Falling Stones	Cab Head Guard : Provide a cab guard to protect the machine from falling stones. Consult your nearest Hitachi dealer.
Freezing Weather	Fuel/Lubricant : Use high quality and low viscosity fuel and oil. Engine Coolant : Be sure to use antifreeze. Battery : Fully charge the batteries at shorter intervals. If not fully charged, electrolyte may freeze. Track : Keep the tracks clean. Park the machine on a hard surface to prevent the tracks from freezing to the ground. DEF/AdBlue® : May become frozen but the machine can be operated normally.



## STORAGE

### Storing the Machine

In case the machine is to be stored for longer than one month, pay attention to the following points to in preparation for the next operation.

#### Precautions for Long-Term Storage

Item	Remedy
Machine Cleaning	Wash the machine. Remove soil or other debris adhered to the machine.
Lubrication/Greasing	Check level of lubricant and contamination. Fill up or change if necessary. Lubricate all grease points. Coat exposed metal surfaces that are subject to rust with grease. (i.e. cylinder rods etc.)
Battery	Remove the batteries and store them in a dry protected place after charging fully. Turn the battery disconnect switch to the OFF position.
Coolant	Add anti-rusting agent. If storing in extremely cold areas, either add extra anti-freeze or drain coolant completely to avoid freezing. In this case, place a sign reading "NO COOLANT".
Protection Against Dust and Moisture	Store the machine in a dry storage area using a protective cover.
Tools	Inspect and repair, then store.
Lubrication Operation	If the oil film on the metal surfaces is lost, rust may occur. This may cause abnormal wear of the machine when the machine operation is restarted. If the machine is to be stored for a long time, at least once a month operate the following hydraulic functions two to three times for lubrication: Travel, swing and digging. Be sure to check the coolant level and lubrication conditions before operating. To protect each part of the compressor from a lack of lubricant, operate the air conditioner at least once a month for several minutes with the engine running at a slow speed during off-season.
DEF/AdBlue®	DEF/AdBlue® may become ammonia when storing it under 40°C for one month or longer. Change DEF/AdBlue® if ammonia odor is observed when opening the tank cap.

 **NOTE:**

- *Lubricating operation is a series of warm-up, travel, swing and digging operation carried out repeatedly for a few cycles at slow speed.*
- *Lubricants will deteriorate during long term storage of the machine. Be sure to carefully check the lubricants before restarting operation of the machine.*

### Precautions for Disconnecting or Connecting Batteries

In case the batteries are kept disconnected for more than one month or when the batteries are reconnected, contact your authorized dealer. Resetting of the Information Controller may be required.





# TROUBLESHOOTING

## Troubleshooting

If any machine trouble has occurred, immediately repair it. Make certain the cause of the trouble and take necessary measures to prevent the reoccurrence of the same trouble.

In case troubleshooting is difficult, or measures marked with \* must be taken, consult your authorized dealer. Never attempt to adjust, disassemble, or repair the hydraulic and/or electrical/electronic parts/components.

**IMPORTANT: Never attempt to disassemble or modify the hydraulic and electrical/electronic components.**

### Engine

Consult your authorized dealer for the engine troubleshooting.

### Engine Auxiliaries

Problem	Cause	Solution
Batteries will not be charged.	Broken battery separator	Replace
	Faulty regulator	* Adjust and replace
	Faulty ground line	* Repair
	Faulty alternator	* Repair or replace
Batteries discharge quickly after being charged.	Shorted cable	* Repair or replace
	Shorted battery separator	Replace
	Increased sediment in battery	Replace
Coolant temperature is too high.	Low coolant level	Refill
	Insufficient fan belt tension	Adjust
	Damaged rubber hose	* Replace
	Faulty thermostat	* Replace
	Faulty coolant temperature gauge	* Replace

Items with \* mark: Consult your authorized dealer.

## TROUBLESHOOTING

<b>Impossible to Start the Engine</b>			
Problem	Cause	Solution	
Engine will not start	Starter does not rotate or is not powerful.	Discharged battery	Charge or replace battery.
		Disconnected, loose, or corroded battery terminals	After repairing the corroded area, securely tighten the connectors.
		Lowered pilot control shut-off lever.	Pull pilot control shut-off lever up.
		Disconnected, loose, or corroded starter ground line terminals.	After repairing the corroded area, securely tighten the connectors.
		Faulty pilot control shut-off lever electrical system	* Repair
		Too high engine oil viscosity	Change engine oil with appropriate viscosity.
		Faulty starter and/or electrical system	* Repair and replace
		Battery Disconnect Switch is in the OFF position	Turn the disconnect switch to the ON position
	Starter rotates.	No fuel	After checking that no fuel is leaking, refill fuel.
		Air in the fuel system	Bleed air.
		Clogged fuel main filter	Replace element
		Clogged fuel pre-filter	Replace element
		Frozen fuel	Warm the fuel pump with hot water or wait until the atmospheric temperature rises.
		Engine stop switch is ON	* Repair and replace
Faulty preheat system		* Repair and replace	
Even though the engine is started, the engine stalls soon.	Too low idle speed	* Repair and replace	
	Clogged fuel main filter	Replace element.	
	Clogged fuel pre-filter	Replace element.	
	Faulty engine control system	* Repair and replace	
	Clogged air cleaner	Clean or replace the element.	
	Faulty fuel system	* Repair and replace	
Engine runs irregularly.	Faulty fuel system	* Repair and replace	
	Water or air in the fuel system	Drain water or bleed air.	
	Faulty engine control system	* Repair and replace	
	Clogged aftertreatment device	* Repair and replace	

Items with \* mark: Consult your authorized dealer.

## TROUBLESHOOTING

<b>Control Lever</b>		
Problem	Cause	Solution
Lever is heavy to operate.	Rusted joint	* Lubricate or repair
	Worn pusher	* Replace
Does not move smoothly.	Worn pusher	* Repair or replace
	Faulty pilot valve	* Replace
Does Not Return to Neutral.	Faulty pilot valve	* Replace
The lever is tilted in the neutral position due to increase in play.	Worn joint	* Repair or replace
	Faulty pilot valve	* Replace

Items with \* mark: Consult your authorized dealer.

## TROUBLESHOOTING

### Hydraulic System

When the machine is stored without operation, air mixed in hydraulic oil will become separated and will accumulate in the cylinder upper sections, causing a delay in the response time of the machine movement or weak power development.

In case these symptoms appear, repeatedly operate all actuators several times.

Problem	Cause	Solution
No hydraulic Functions (Noise from pumps)	Faulty hydraulic pump	* Repair or replace
	Lack of hydraulic oil	Refill
	Broken suction pipe and/or hose	* Repair or replace
No hydraulic Functions (Hydraulic pump noise remains unchanged.)	Faulty pilot pump	* Replace
	Faulty pilot shut-off solenoid valve	* Replace
	Faulty wire harness (pilot shut-off solenoid valve) pilot shut-off switch.	* Repair or replace
	The pilot control shut-off lever is in the LOCK position.	Turn it to the UNLOCK Position.
All actuators have no power.	Malfunction due to worn hydraulic pump	* Replace
	Decreased main relief valve set pressure in the control valve	* Adjust
	Lack of hydraulic oil	Refill
	Clogged suction strainer in the hydraulic oil tank	Clean
	Absorption of air from the oil suction side	Retighten
	Faulty pressure sensor.	* Replace
	Faulty solenoid valve	* Replace
Only one side lever is inoperable or has no power.	Faulty relief valve in the valve	* Repair or replace
	Broken pipe and/or hose	* Repair or replace
	Loose pipe line joint	Retighten
	Broken O-ring at pipe line joint	* Replace
	Faulty hydraulic pump	* Repair or replace
	Faulty pilot valve	* Replace
	Faulty pilot circuit line	* Repair or replace
	Faulty pilot solenoid valve	* Repair or replace

Items with \* mark: Consult your authorized dealer.

## TROUBLESHOOTING

Problem	Cause	Solution
Only one actuator is inoperable.	Broken control valve spool	* Replace
	Embedded foreign matter in valve spool	* Repair or replace
	Broken pipe and/or hose	* Repair or replace
	Loose pipe line joint	Retighten
	Broken O-ring at pipe line joint	* Replace
	Broken actuator	* Repair or replace
	Faulty pilot valve	* Replace
	Faulty pilot circuit line	* Repair or replace
Only one cylinder is inoperable or has no power.	Faulty pilot solenoid valve	* Repair or replace
	Broken oil seal in cylinder	* Repair or replace
	Oil leak due to damage to cylinder rod	* Repair or replace
	Faulty pilot valve	* Replace
	Faulty pilot circuit line	* Repair or replace
Hydraulic oil temperature increases.	Faulty pilot solenoid valve	* Repair or replace
	Stained oil cooler	Clean
	Insufficient engine fan belt tension	Adjust
Oil leak from low pressure hose.	Insufficient rotation speed of hydraulically driven fan	* Repair or replace
	Loose clamps	Retighten
	Faulty suction manifold	* Repair or replace

Items with \* mark: Consult your authorized dealer.

## TROUBLESHOOTING

<b>Drive Function</b>		
Problem	Cause	Solution
One or both side tracks are inoperable.	Damaged center joint	* Repair or replace
	Incompletely released parking brake	* Repair or replace
	Broken travel motor	* Repair or replace
	Faulty pilot valve	* Replace
	Faulty pilot circuit line	* Repair or replace
Does not travel smoothly.	Overly tensioned or slackened crawler sag	Adjust
	Lack of lubricant in front idler and/or roller	Refill
	Deformed track frame	* Repair or replace
	Embedded foreign matter such as rock fragments	Remove
	Dragged parking brake	* Repair
Travel speed does not change.	Faulty travel mode switch.	* Replace
	Faulty pressure sensor.	* Replace
	Pump 1 and 2 delivery pressure sensors	
	Pumps 1, 2 control pressure sensors	
	Poor contact in connectors	* Repair or replace
	Damaged wire harness	* Repair
	Faulty controller (MC)	* Replace
	Faulty solenoid valve	* Repair or replace
Faulty motor	* Repair or replace	

Items with \* mark: Consult your authorized dealer.

## TROUBLESHOOTING

<b>Swing Function</b>		
Problem	Cause	Solution
Upperstructure does not swing.	Faulty swing parking brake	* Repair or replace
	Faulty swing parking brake release valve	* Repair or replace
	Broken swing motor	* Repair or replace
	Faulty pilot valve	* Replace
	Faulty pilot circuit line	* Repair or replace
Swing is not smooth.	Worn swing gear	* Repair or replace
	Damaged swing bearing and bearing balls.	* Repair or replace
	Lack of grease	Refill
	Inversion protective valve	* Repair or replace

Items with \* mark: Consult your authorized dealer.

Just after the control valve, swing motor relief valve and/or the swing motor is replaced, a noise may be emitted and/or operation may not be performed smoothly due to air trapped in the hydraulic line.

Slowly continue to operate the machine for approx. 10 minutes to bleed air.

After repair work is complete, be sure to check the oil level in the hydraulic oil tank. Refill hydraulic oil as needed.



## TROUBLESHOOTING

### Engine Speed

Problem	Cause	Solution
Even if operating the engine control dial, the engine speed does not change.	Blown fuse	Replace
	Faulty engine control dial	* Replace
	Poor contact in connector	* Repair or replace
	Damaged wire harness (between EC dial and MC, or MC and ECM)	* Repair
	Faulty controller (MC, ECM)	* Replace
	Performing manual regeneration	(Normal control)
Work mode does not change.	Faulty mode switch	* Replace
	Poor contact in connector	* Repair or replace
	Damaged wire harness (between MC and monitor)	* Repair
	Faulty controller (MC)	* Replace
	Faulty solenoid valve	* Repair or replace
Auto-idle is inoperable or not released.	Faulty pressure sensor.	* Replace
	Poor contact in connector	* Repair or replace
	Damaged wire harness	* Repair
	Faulty controller.	* Replace
	Performing manual regeneration	(Normal control)

Items with \* mark: Consult your authorized dealer.

### Pump Control

Problem	Cause	Solution
Front attachment and/or travel speed is slow.	Blown control fuse	Replace
	Poor contact in connector	* Repair or replace
	Damaged wire harness	* Repair
	Faulty controller.	* Replace
	Faulty pump solenoid valve.	* Replace
	Faulty pressure sensor.	* Replace

Items with \* mark: Consult your authorized dealer.

### Others

The machine may have a noise, excessive vibration, and abnormal smell when any trouble occurs. Always beware of the machine conditions during operation.

## SPECIFICATIONS

### Specifications

#### ZX135US-6

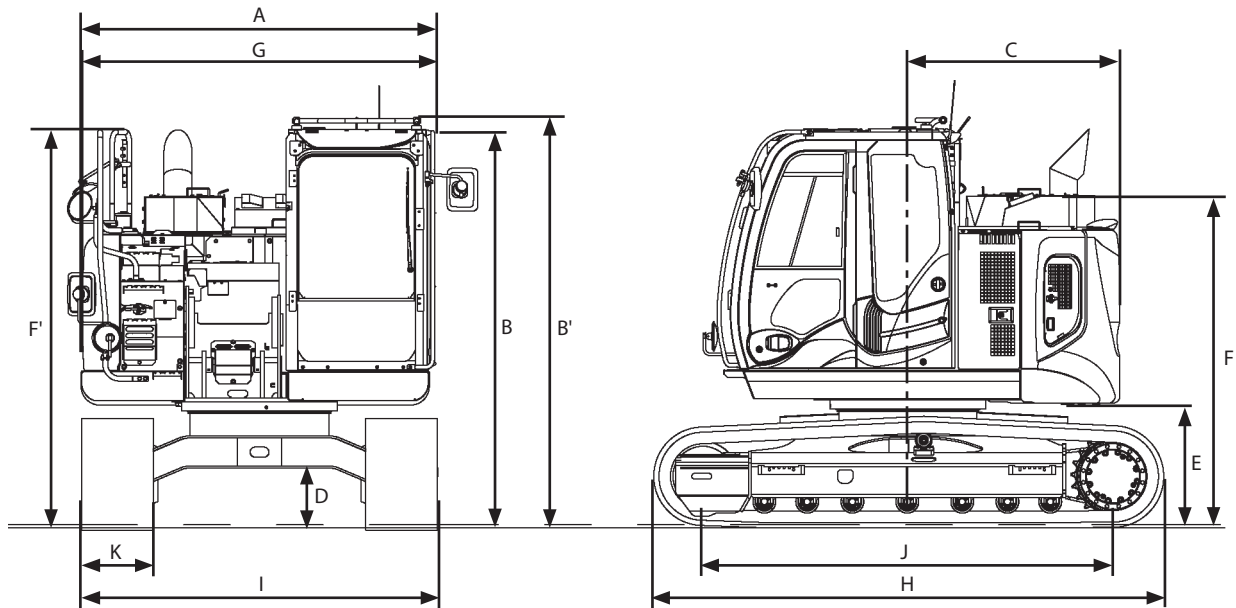

MDAT-12-011

Model	ZX135US-6
Type of Front-End Attachment	2.52 m Arm
Bucket Capacity (Heaped)	PCSA 0.50 m <sup>3</sup> , CECE 0.45 m <sup>3</sup>
Counterweight Weight	3520 kg
Operating Weight	13800 kg
Base Machine Weight	11100 kg
Engine Type	Isuzu AR-4JJ1XASA-02
Engine Power	ISO 14396: 74.9 kW/2000 min <sup>-1</sup> (102 PS/2000 rpm)
A: Overall Width (Excluding back mirrors)	2490 mm
B: Cab Height	2790 mm
B': Cab Top Handrail Height	2870 mm
C: Rear End Swing Radius	1490 mm
D: Minimum Ground Clearance	*410 mm
E: Counterweight Clearance	*840 mm
F: Engine Cover Height	*2320 mm
F': Body Top Handrail Height	2870 mm
G: Overall Width of Upperstructure	2490 mm
H: Undercarriage Length	3580 mm
I: Undercarriage Width	2490 mm
J: Sprocket Center to Idler Center	2880 mm
K: Track Shoe Width	500 mm (Grouser shoe)
Ground Pressure	43 kPa (0.44 kgf/cm <sup>2</sup> )
Swing Speed	13.5 min <sup>-1</sup> (rpm)
Travel Speed (fast/slow)	5.5/3.3 km/h
Gradeability	35 ° (tanθ = 0.70)

 NOTE: \* The dimensions do not include the height of the shoe lug.

## SPECIFICATIONS

### Working Ranges (Grouser shoe)

ZX135US-6

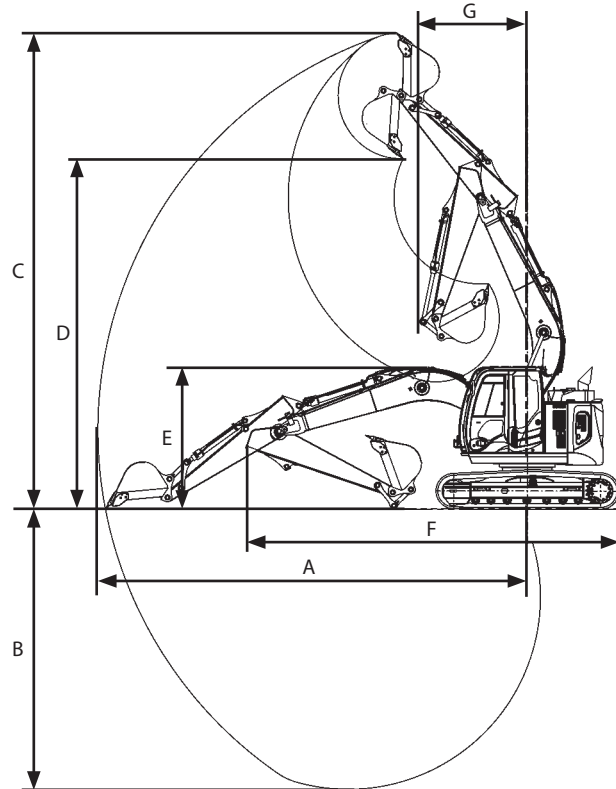

MDAT-12-002

Item	Category	3.01 m Arm
		Backhoe
		mm
A: Maximum Digging Reach		8860
B: Maximum Digging Depth		5980
C: Maximum Cutting Height		9690
D: Maximum Dumping Height		7220
E: Overall Height		*2780
F: Overall Length		7390
G: Minimum Swing Radius		2450

 **NOTE:** The dimensions do not include height of the shoe lug (except Item E). \*The dimensions asterisked are for transport pin position.

## SPECIFICATIONS

### Shoe Types and Applications

#### ZX135US-6

Shoe Width		500 mm Grouser Shoe	600 mm Grouser Shoe	700 mm Grouser Shoe
Application		For Ordinary Ground (Standard)	For Weak Footing (Option)	For Weak Footing (Option)
Operating Weight	kg	13800	14100	14300
Base Machine Weight	kg	11100	11400	11700
Counterweight Weight	kg	3520	3520	3520
Cab Height	mm	2790	2790	2790
Minimum Ground Clearance	mm	*410	*410	*410
Undercarriage Length	mm	3580	3580	3580
Undercarriage Width	mm	2490	2590	2690
Ground Pressure		43 kPa (0.44 kgf/cm <sup>2</sup> )	37 kPa (0.38 kgf/cm <sup>2</sup> )	32 kPa (0.33 kgf/cm <sup>2</sup> )

 NOTE:

- The Specifications for the front-end attachment is for 2.52 m arm with PCSA 0.50 m<sup>3</sup> bucket.
- Other than 500 mm grouser shoe should not be used on gravel or rocky ground.
- \* The dimensions do not include the height of the shoe lug.

## SPECIFICATIONS

### Bucket Types and Applications

#### ZX135US-6

Bucket	Bucket Capacity m <sup>3</sup>		Bucket Width mm		Front-End Attachment
	PCSA (Heaped)	CECE (Heaped)	With Side Cutters	Without Side Cutters	3.01 m Arm
Hoe Bucket	0.19	0.17	550	450	●
	0.30	0.25	700	580	●
	0.40	0.33	800	680	●
	0.45	0.40	970	850	○
	0.50	0.45	1010	890	*○
	0.59	0.50	1070	950	-
	0.66	0.55	-	1030	-
Reinforced Hoe Bucket	0.50	0.45	1010	890	*○
Reinforced Hoe Bucket	0.59	0.50	1070	950	-
One Point Ripper	-	-	-	-	-
Slope-Finishing Blade	-	-	1000 x 1600		◇
V-Type Bucket	-	-			○

 **NOTE:**

- Symbols in the above table have the following meanings.
  - : General excavating
  - : Light duty excavating
  - : Rock digging
  - : Loading work
  - ◇ : Slope-finishing work
  - : Not applicable (not warrantable)
- Hoe bucket is applicable to the following types of work.
  - General excavating:  
For digging and loading operation of sand, gravel, clay, ordinary earth and so on.
  - Light duty excavating:  
For digging and loading operation of dry, loosened earth, sand, mud and so on.  
Their bulk density shall be less than 1.60 t/m<sup>3</sup> as a standard.
  - Loading:  
For loading operation of dry, loosened earth and sand.  
Their bulk density shall be less than 1.10 t/m<sup>3</sup> as a standard.
  - Rock digging:  
For digging/loading operation of mountain gravels, blasted rock, hard clay, soft rock and so on.
- \* Applicable only to 700 mm grouser shoe.

**IMPORTANT: Using inapplicable buckets may cause serious damage to the front structure such as boom, arm and hydraulic cylinders.**

## SPECIFICATIONS

### Specifications

#### ZX225USLC-6

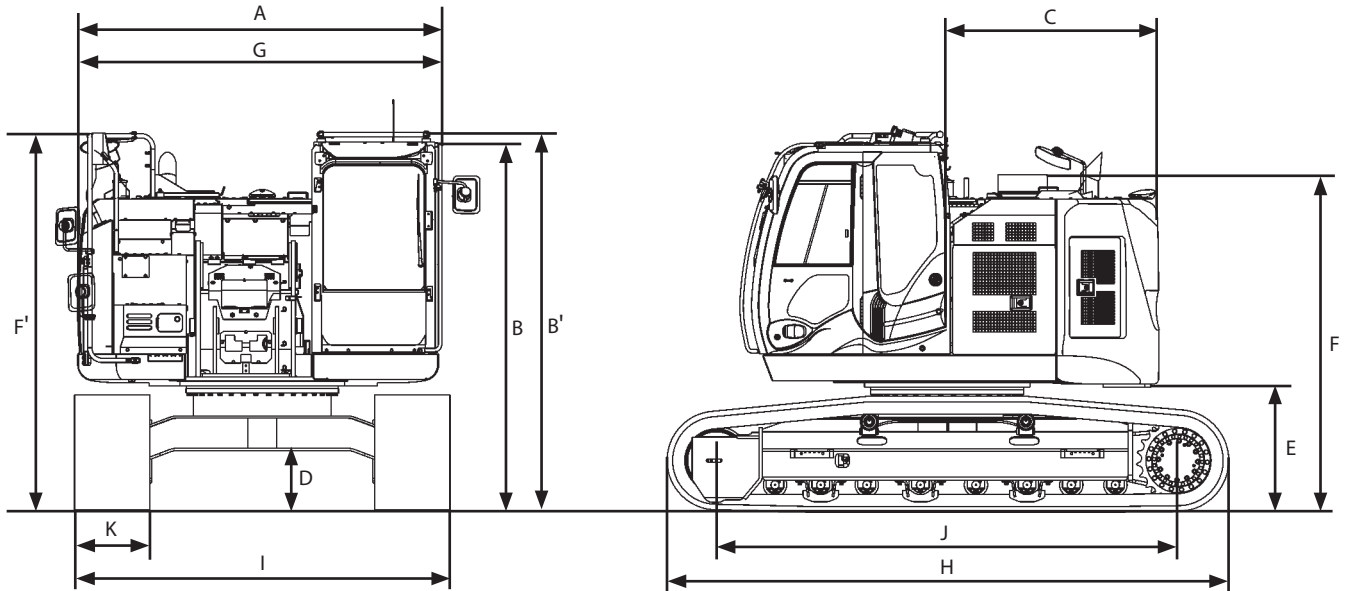

MDAT-12-007

Model	ZX225USLC-6
Type of Front-End Attachment	2.91 m Arm
Bucket Capacity (Heaped)	PCSA 0.80 m <sup>3</sup> , CECE 0.70 m <sup>3</sup>
Counterweight Weight	7280 kg
Operating Weight	17200 kg
Base Machine Weight	13700 kg
Engine Type	Isuzu AR-4HK1XASA-12
Engine Power	ISO 14396: 122 kW/2000 min <sup>-1</sup> (166 PS/2000 rpm)
A: Overall Width (Excluding back mirrors)	2990 mm
B: Cab Height	2950 mm
B': Cab Top Handrail Height	2990 mm
C: Rear End Swing Radius	1680 mm
D: Minimum Ground Clearance	*450 mm
E: Counterweight Clearance	*980 mm
F: Engine Cover Height	*2660 mm
F': Body Top Handrail Height	3020 mm
G: Overall Width of Upperstructure	2910 mm
H: Undercarriage Length	4460 mm
I: Undercarriage Width	2990 mm
J: Sprocket Center to Idle Center	3660 mm
K: Track Shoe Width	600 mm (Grouser shoe)
Ground Pressure	52 kPa (0.53 kgf/cm <sup>2</sup> )
Swing Speed	11.8 min <sup>-1</sup> (rpm)
Travel Speed (fast/slow)	5.5/3.5 km/h
Gradeability	35 ° (tanθ = 0.70)

NOTE: \* The dimensions do not include the height of the shoe lug.

## SPECIFICATIONS

### Working Ranges (Grouser shoe)

ZX225USLC-6

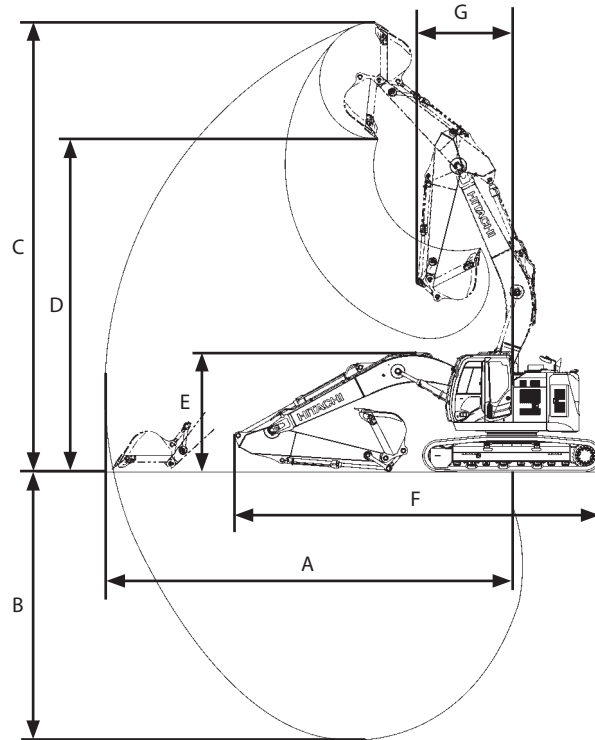

MDAT-12-008

Item	Category	2.42 m Arm	2.91 m Arm
		Backhoe	Backhoe
		mm	mm
A: Maximum Digging Reach		9620	10110
B: Maximum Digging Depth		6120	6620
C: Maximum Cutting Height		10790	11230
D: Maximum Dumping Height		7870	8290
E: Overall Height		3230	2980
F: Overall Length		9270	9110
G: Minimum Swing Radius		2720	2380

 NOTE: The dimensions do not include height of the shoe lug (except Item E).

## SPECIFICATIONS

### Shoe Types and Applications

#### ZX225USLC-6

Shoe Width	600 mm Grouser Shoe	700 mm Grouser Shoe	800 mm Grouser Shoe
Application	For Ordinary Ground (Standard)	For Weak Footing (Option)	For Weak Footing (Option)
Operating Weight	kg 25000	25400	25700
Base Machine Weight	kg 20500	21000	21200
Counterweight Weight	kg 7280	7280	7280
Cab Height	mm 2950	2950	2950
Minimum Ground Clearance	mm *450	*450	*450
Undercarriage Length	mm 4460	4460	4460
Undercarriage Width	mm 2990	3090	3190
Ground Pressure	52 kPa (0.53 kgf/cm <sup>2</sup> )	45 kPa (0.46 kgf/cm <sup>2</sup> )	40 kPa (0.41 kgf/cm <sup>2</sup> )

 **NOTE:**

- The specifications for the front-end attachment is for 2.91 m arm with PCSA 0.8 m<sup>3</sup> bucket.
- Other than 600 mm grouser shoe should not be used on gravel or rocky ground.
- \* The dimensions do not include the height of the shoe lug.



## SPECIFICATIONS

### Bucket Types and Applications

#### ZX225USLC-6

Bucket	Bucket Capacity m <sup>3</sup>		Bucket Width mm (in) (With side cutter)	Application	Front-End Attachment	
	PCSA (Heaped)	CECE (Heaped)			2.42 m Arm	2.91 m Arm
Hoe Bucket	0.51	0.45	830		●	●
	0.80 HD	0.7	1150		●	●
	0.80	0.7	1140		●	●
	0.91	0.8	1260		●	●
	1.10	0.9	1440		○	□
	1.20	1.0	1450 (Without side cutter)		□	–
Bucket reinforcement can be welded in four places upon customer's request	0.80	0.7	1140		●	●
	0.91	0.8	1260		●	●
Reinforced Hoe Bucket HD Type (Transverse- Type-Pin-Used Type)	0.80	0.7	1140		●	●
V-Type Bucket	–		90 °	Excavating V-trenches	○	○
Ripper Bucket		0.50	800 (Without side cutter)		■	–
One Point Ripper	–		–		■	–
Slope-Finishing Blade	–		1800	Bank cutting finish	◇	◇

 **NOTE:**

- Symbols in the above table have the following meanings.
  - : General excavating
  - : Light duty excavating
  - : Rock digging
  - : Loading work
  - ◇ : Slope-finishing work
  - : Not applicable (not warrantable)
- Hoe bucket is applicable to the following types of work.
  - General excavating:  
For digging and loading operation of sand, gravel, clay, ordinary earth and so on.
  - Light duty excavating:  
For digging and loading operation of dry, loosened earth, sand, mud and so on.  
Their bulk density shall be less than 1.60 t/m<sup>3</sup> as a standard.
  - Loading:  
For loading operation of dry, loosened earth and sand.  
Their bulk density shall be less than 1.10 t/m<sup>3</sup> as a standard.
  - Rock digging:  
For digging/loading operation of mountain gravels, blasted rock, hard clay, soft rock and so on.

**IMPORTANT:** Using inapplicable buckets may cause serious damage to the front structure such as boom, arm and hydraulic cylinders.

## SPECIFICATIONS

### Specifications

#### ZX345USLC-6

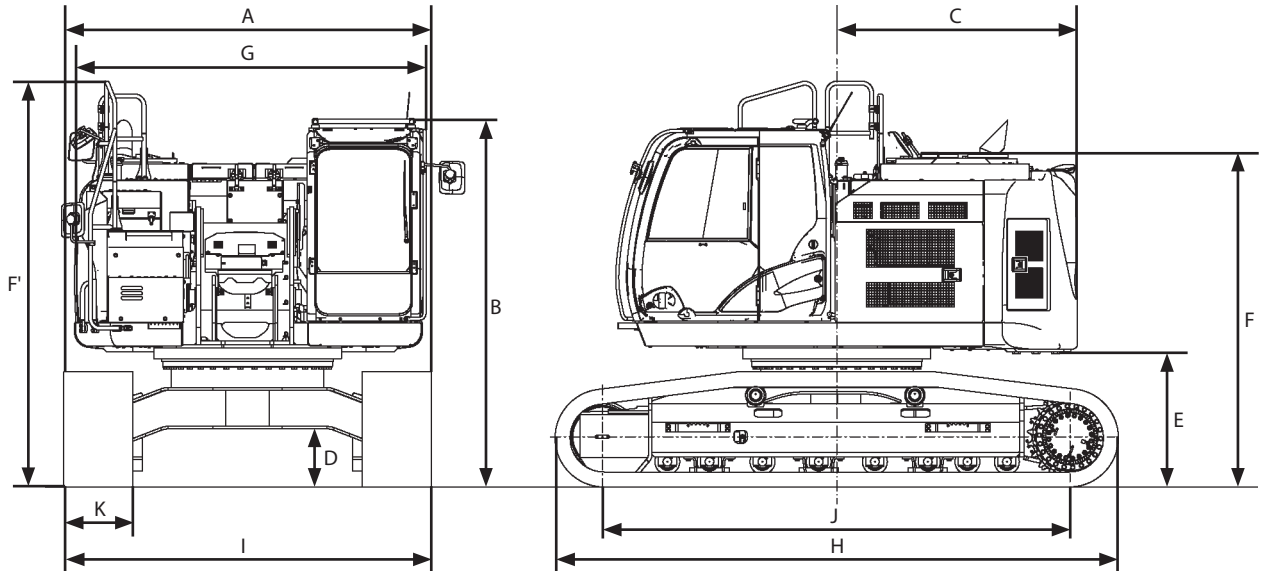

MDD5-12-001

Model	ZX345USLC-6
Type of Front-End Attachment	3.11 m Arm
Bucket Capacity (Heaped)	PCSA 1.25 m <sup>3</sup> , CECE 1.10 m <sup>3</sup>
Counterweight Weight	8680 kg
Operating Weight	36300 kg
Base Machine Weight	21200 kg
Engine Type	Isuzu AQ-6HK1XASA-02S
Engine Power	ISO 14396: 186 kW/1900 min <sup>-1</sup> (253 PS/1900 rpm)
A : Overall Width (Excluding back mirrors)	3190 mm
B : Cab Height	3230 mm
C : Rear End Swing Radius	2090 mm
D : Minimum Ground Clearance	*500 mm
E : Counterweight Clearance	*1160 mm
F : Engine Cover Height	*2900 mm
F' : Body top Handrail Height	3590 mm
G : Overall Width of Upperstructure	3050 mm
H : Undercarriage Length	4940 mm
I : Undercarriage Width	3190 mm
J : Sprocket Center to Idler Center	4050 mm
K : Track Shoe Width	600 mm (Grouser shoe)
Ground Pressure	66 kPa (0.67 kgf/cm <sup>2</sup> )
Swing Speed	10.5 min <sup>-1</sup> (rpm)
Travel Speed (fast/slow)	4.1/2.6 km/h
Gradeability	35 ° (tanθ = 0.70)

 NOTE: \* The dimensions do not include the height of the shoe lug.

# SPECIFICATIONS

## Working Ranges

ZX345USLC-6

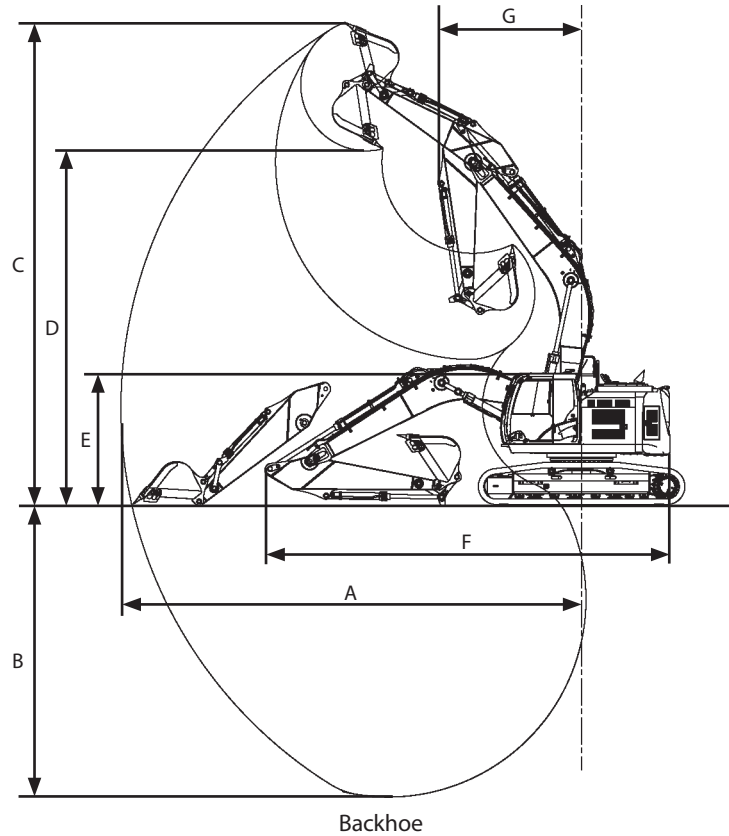

MDD5-12-002

Item	Category	3.11 m Arm	3.76 m Arm
		Backhoe	Backhoe
		mm	mm
A: Maximum Digging Reach		10900	11460
B: Maximum Digging Depth		*6920	*7570
C: Maximum Cutting Height		*11410	*11690
D: Maximum Dumping Height		*8380	*8670
E: Overall Height		3590	3590
F: Overall Length		9960	10020
G: Minimum Swing Radius		3400	3390

**NOTE:** \* The dimensions do not include the height of the shoe lug.

## SPECIFICATIONS

### Shoe Types and Applications

#### ZX345USLC-6

Shoe Width	600 mm Grouser Shoe	700 mm Grouser Shoe	800 mm Grouser Shoe
Application	For Ordinary Ground (Standard)	For Weak Footing (Option)	For Weak Footing (Option)
Operating Weight      kg	36300	36900	37300
Base Machine Weight      kg	21200	21800	22200
Cab Height      mm	3230	3230	3230
Minimum Ground Clearance      mm	* 500	* 500	* 500
Undercarriage Length      mm	4940	4940	4940
Undercarriage Width      mm	3190	3290	3390
Ground Pressure	68 kPa (0.69 kgf/cm <sup>2</sup> )	59 kPa (0.60 kgf/cm <sup>2</sup> )	52 kPa (0.53 kgf/cm <sup>2</sup> )

 **NOTE:**

- The Specifications for the front-end attachment is for 3.11 m arm with PCSA 1.25 m<sup>3</sup> bucket.
- 700, 800 mm grouser shoe should not be used on gravel or rocky ground.
- \* The dimensions do not include the height of the shoe lug.

## SPECIFICATIONS

### Bucket Types and Applications

#### ZX345USLC-6

Bucket	Bucket Capacity m <sup>3</sup>		Bucket Width mm (With side cutter)	Application	Front-End Attachment	
	PCSA (Heaped)	CECE (Heaped)			3.11 m Arm	3.76 m Arm
Hoe Bucket	1.00	0.90	1260		●	●
	1.25	1.10	1490		●	●
	1.40	1.20	1630		○	□
	1.62	1.40	1830		-	-
Bucket reinforcement can be welded in four places upon customer's request	1.10	1.00	1350		●	●
	1.40	1.20	1630		○	□
Rock Bucket	0.92	0.80	1210		■	-
Ripper Bucket	0.80	0.70	1000 (Without side cutter)		■	-
One Point Ripper	-	-	-		■	-
Clamshell Bucket		0.80	Bucket width 975	Side ditching	●	-

 **NOTE:**

- Symbols in the above table have the following meanings.

● : General excavating

○ : Light duty excavating

■ : Rock digging

□ : Loading work

◇ : Slope-finishing work

- : Not applicable (not warrantable)

- Hoe bucket is applicable to the following types of work.

*General excavating:*

*For digging and loading operation of sand, gravel, clay, ordinary earth and so on.*

*Light duty excavating:*

*For digging and loading operation of dry, loosened earth, sand, mud and so on.*

*Their bulk density shall be less than 1.60 t/m<sup>3</sup> as a standard.*

*Loading:*

*For loading operation of dry, loosened earth and sand.*

*Their bulk density shall be less than 1.10 t/m<sup>3</sup> as a standard.*

*Rock digging:*

*For digging/loading operation of mountain gravels, blasted rock, hard clay, soft rock and so on.*

**IMPORTANT:** Using inapplicable buckets may cause serious damage to the front structure such as boom, arm and hydraulic cylinders.

## OPTIONAL ATTACHMENTS AND DEVICES

### PAD CRAWLER SHOE

---

#### Using Pad Crawler Shoe

Pad crawler is a track link on which a rubber pad is installed so the machine does not damage road surfaces when traveling. Be sure to observe all precautions for handling pad crawler. Avoid operating the machine in the following conditions:

##### Forbidden Operations

Do not operate on sharp, rocky, uneven surfaces, such as river rock, gravel, etc.

Do not allow engine oil, gasoline, etc. to remain on the track, and avoid traveling in oil in order to reduce the danger of slipping.

While raising the machine using the front attachment do not allow the other side track to drive, possibly causing personal injury, damaging or displacing pad crawler.

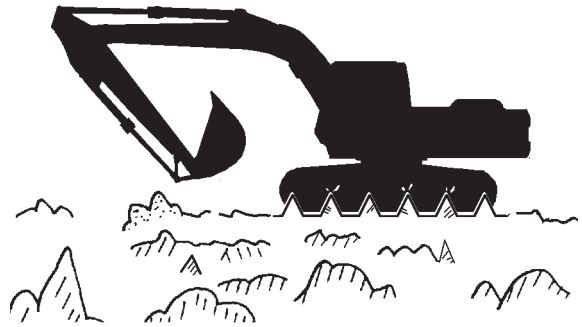

M107-05-051

## OPTIONAL ATTACHMENTS AND DEVICES

### PAD CRAWLER SHOE

---

#### Traveling and Other Cautions

Do not keep the pad crawler shoe under direct sunlight for more than three months.

Avoid reckless steering operations on concrete road to the extent possible, as this will cause wear to the shoe lug. Also, avoid running on asphalt road of more than 60 °C (140 °F) in temperature, as this will cause wear to the shoe as well as damage to the road surface.

Ease the machine down from the jacked-up position. Do not let it drop.

Pad crawler has large friction force. Therefore to avoid damaging the pad crawler slowly operate the control levers to gradually turn the machine.

After raising one side track with the front attachment, slowly lower the pad crawler equipped machine.

If the pad crawler becomes severely damaged, contact your nearest Hitachi Dealer for replacement.

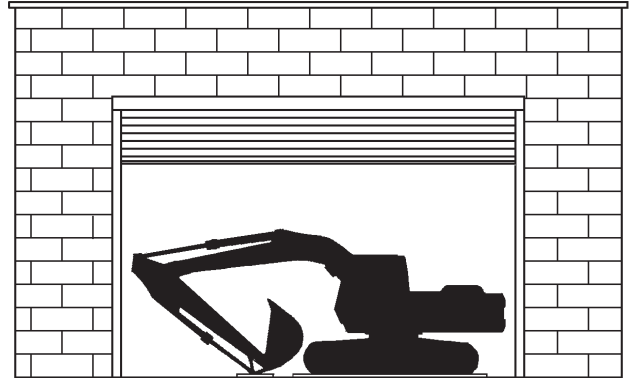

M107-05-052

## OPTIONAL ATTACHMENTS AND DEVICES

### PAD CRAWLER SHOE

#### Transporting

##### Transporting

**⚠ CAUTION:** Fasten chains or cables to the machine frame. Do not place chains or cables over or against the hydraulic lines or hoses.

1. Place blocks in front of and behind the tracks.
2. Fasten each corner of the machine and front attachment to the trailer with a chain or cable.



M107-06-013

#### Precautions for Transporting Machines with Pad Crawler Shoes

When transporting a machine with pad crawler shoes, be sure to fasten the right and left track frames securely to the flatbed with wire ropes and soft protectors, as shown. Do not allow wire ropes to come into direct contact with pad crawler shoes.

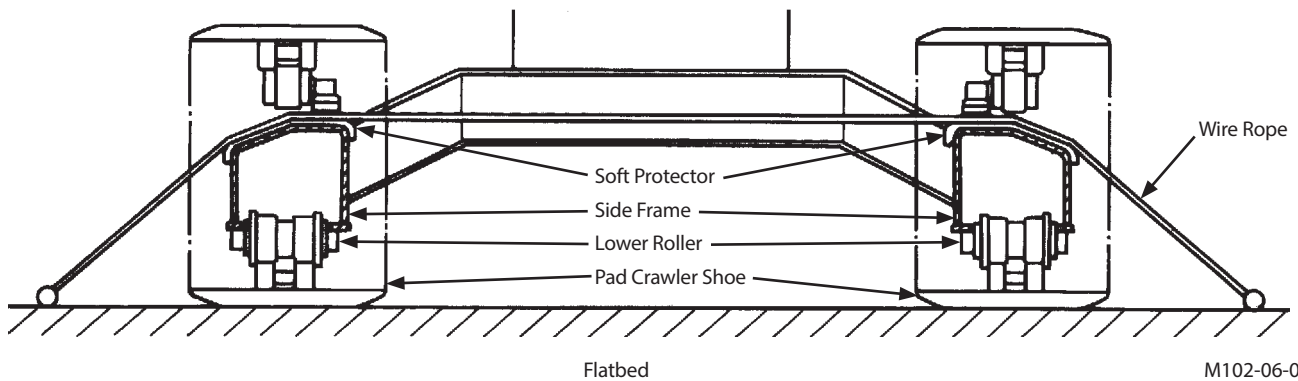



## OPTIONAL ATTACHMENTS AND DEVICES

### PAD CRAWLER SHOE

#### Check Track Sag --- every 50 hours

Swing the upperstructure 90 ° and lower the bucket to raise the track off the ground as shown.

Keep the angle between the boom and arm 90 to 110 ° and position the bucket's round side on the ground. Place blocks under the machine frame to support the machine. Rotate the raised track in reverse two full rotations and then forward two full rotations.

Measure distance (A) at the middle of the track frame from the bottom of the track frame to the back face of the track shoe.

#### Track sag specifications

Model	A
ZX135US-6	250 to 280 mm
ZX225USLC-6	300 to 335 mm
ZX345USLC-6	340 to 380 mm

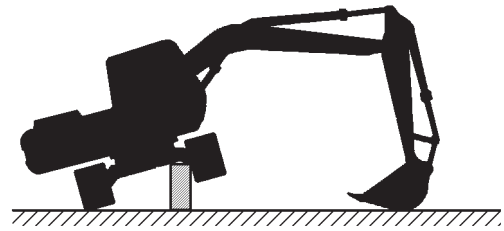

M104-07-067

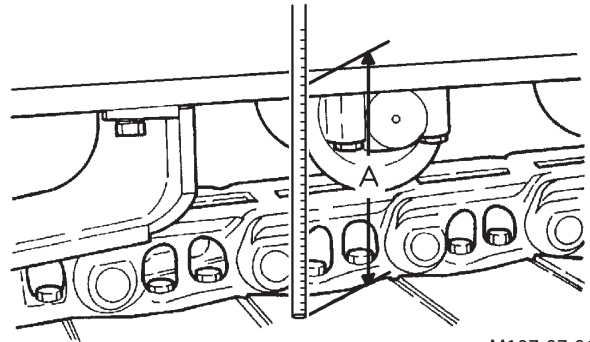

M107-07-068

 **NOTE:** Check track sag after thoroughly removing soil stuck on the track area by washing.

#### Adjust Track Sag

##### Precautions for Adjusting Track Sag

1. If track sag is not within specifications, loosen or tighten the track following the procedures shown on the next page.
2. When adjusting track sag, lower the bucket to the ground to raise one track off the ground. Repeat this procedure to raise the other track. Each time, be sure to place blocks under the machine frame to support the machine.
3. After adjusting track sag of both tracks, move the machine back and forth several times.
4. Check track sag again. If track sag is not within specifications, repeat adjustment until correct sag is obtained.

## OPTIONAL ATTACHMENTS AND DEVICES

### PAD CRAWLER SHOE

#### Loosen the Track (ZX135US-6)

**CAUTION:** Do not loosen valve (1) quickly or loosen it too much as high-pressure grease in the adjusting cylinder may spout out. Loosen carefully, keeping body parts and face away from valve (1). Never loosen grease fitting (2).

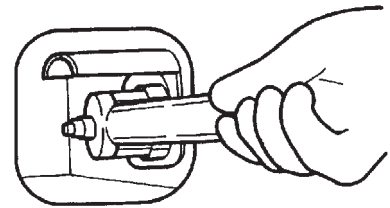

M107-07-075

**IMPORTANT:** When gravel or mud is packed between sprockets and track links, remove it before loosening.

1. To loosen the track, slowly turn valve (1) counterclockwise using long socket 19; grease will escape from the grease outlet.
2. Between 1 to 1.5 turns of valve (1) is sufficient to loosen the track.
3. If grease does not drain smoothly, slowly rotate the raised track.
4. When proper track sag is obtained, turn valve (1) clockwise and tighten to 90 N·m (9.0 kgf·m).

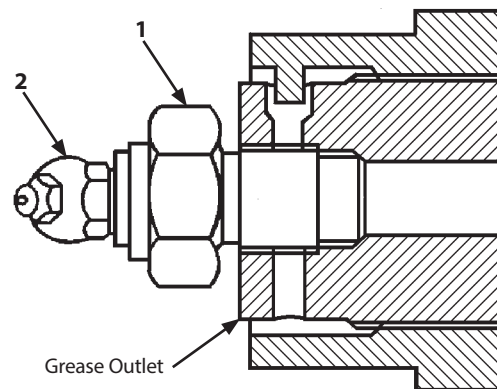

M104-07-119

#### Tighten the Track

**CAUTION:** It is abnormal if the track remains tight after turning valve (1) counterclockwise or if the track is still loose after charging grease to fitting (2). In such cases, NEVER ATTEMPT TO DISASSEMBLE the track or track adjuster, because of dangerous high-pressure grease inside the track adjuster. See your authorized dealer immediately.

To tighten the track, connect a grease gun to grease fitting (2) and add grease until the sag is within specifications.

## OPTIONAL ATTACHMENTS AND DEVICES

### PAD CRAWLER SHOE

#### Loosen the Track (ZX225USLC-6)

**CAUTION:** The pressure inside the cylinder of the track adjuster is high. Do not loosen valve (1) quickly or loosen it too much as valve (1) may fly out or high-pressure grease in the adjusting cylinder may spout out. Slowly loosen valve (1) while keeping body parts and face away from valve (1). Never loosen grease fitting (2).

**IMPORTANT:** When gravel or mud is packed between sprockets and track links, remove it before loosening.

1. To loosen the track, slowly turn valve (1) counterclockwise using long socket 24; grease will escape from the grease outlet.
2. Between 1 to 1.5 turns of valve (1) is sufficient to loosen the track. When valve (1) comes in contact with stop plate (3), do not loosen valve (1) further.
3. If grease does not drain smoothly, slowly rotate the raised track.

**CAUTION:** To prevent accidents, care should be taken to ensure that hands, feet, and any body parts do not become entangled when working around the tracks.

4. When proper track sag is obtained, turn valve (1) clockwise to the original condition.

Tightening Torque: 90 N·m (9.0 kgf·m)

Do not remove valve stop plate (3). Do not loosen bolt (4) while adjusting the track sag.

**CAUTION:** Consult your authorized dealer if grease is not sufficiently drained.

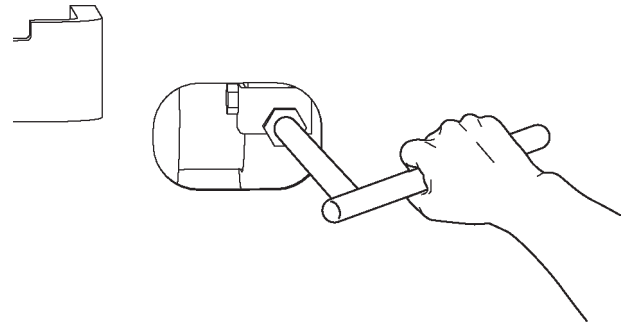

MDAA-07-013

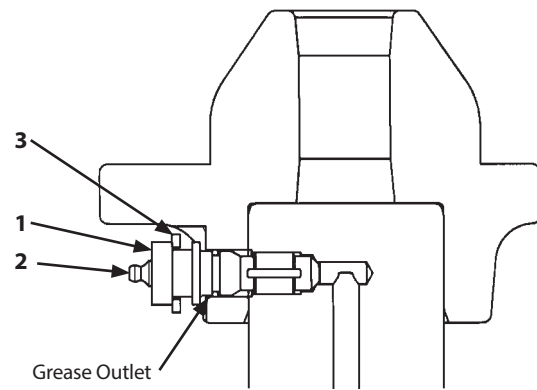

MDAA-07-014

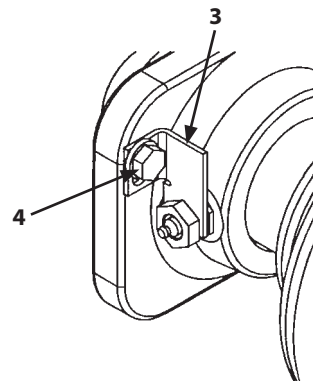

MDAA-07-057

## OPTIONAL ATTACHMENTS AND DEVICES

### PAD CRAWLER SHOE

---

#### Tighten the Track

**⚠ CAUTION:** It is abnormal if the track can not be adjusted. The strong force acts on the spring in track adjuster. Therefore, the grease in cylinder is highly pressurized. In such cases, **NEVER ATTEMPT TO DISASSEMBLE** the track or track adjuster, because of dangerous high-pressure grease inside the track adjuster. See your authorized dealer immediately.

To tighten the track, connect a grease gun to grease fitting (2) and add grease until the sag is within specifications.

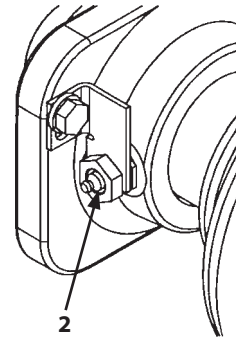

MDAA-07-057

## OPTIONAL ATTACHMENTS AND DEVICES

### LONG ARM OPERATION

#### Long Arm Operation

##### ZX135US-6

1. The optional [3.01 m] long arm is only for light works such as loam loading, sludge handling, etc.. Do not use it for heavy works such as digging gravel. When the arm is used for digging, apply shallow cut to the ground to avoid tough digging, or arm damage may result.
2. When the machine is equipped with the [3.01 m] long arm, the hoe-bucket size must be limited to the followings due to stability and strength of the machine;
  - \* PCSA 0.45 m<sup>3</sup>
  - PCSA 0.50 m<sup>3</sup>
  - \* with 700 mm shoe
3. When the machine is equipped with the long arm, connect the arm cylinder end to:
  - Pin bore A (when the machine is in operation)
  - Pin bore B (when the machine is transported)

**IMPORTANT:** Connect the arm cylinder rod end to pin bore B only when the machine is transported. Do not operate the digging or loading function with the arm cylinder connected to pin bore B as the bucket may hit the cab accidentally with this connection.

When transporting the machine, follow the procedure shown below to convert it into the transporting posture.

- (a) Position the bucket cylinder with rod retracted a little from the fully extended position.
- (b) Position the arm cylinder with rod retracted a little from the fully extended position.
- (c) Lower the boom until the arm top comes into contact with the ground.

Unit: mm

Arm Cylinder Rod End Connected To:	Height of Front Attachment (H)	
	ZX135US-6	
	Without Bucket	With Bucket
Pin Bore A	2900	3160
Pin Bore B	2610	2760

Dimensions include shoe lug height.



M163-05-001

# OPTIONAL ATTACHMENTS AND DEVICES

## BLADE

### Blade Lever

#### ZX135US-6, 225USLC-6

Use blade lever (1) on the operator's right to raise and lower the blade.

When the lever is released, it automatically returns to neutral, keeping the blade in its position until the lever is operated again.

- 1- Blade Lever
- 2- Blade Raise
- 3- Neutral
- 4- Blade Lower

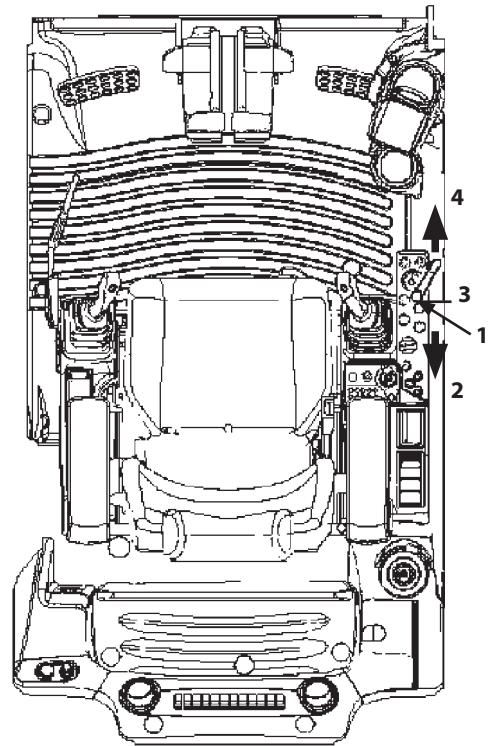

MDAA-13-001

### Precautions for Blade Operation

This blade is designed as a light service attachment for the hydraulic excavator. Please keep the following points in mind:

1. This blade is designed to be used for dozing work only. Do not attempt to dig deeply with the blade. Doing so will damage not only the blade but the undercarriage as well.
2. Do not apply intensive or uneven loads. Never apply high-speed impact to the blade by running the machine into a load.
3. Jacking up the machine with this blade, the surface beneath the blade comes under high pressure, increasing the risk of surface collapse.  
  
Always be sure that the surface is strong enough to support the weight of the machine during operation.  
  
Avoid dangerously uneven distribution of weight on the blade by maintaining even contact between the blade and the ground.
4. Never use this blade as an outrigger.
5. Avoid contact between the bucket and the blade while digging.



M155-14-008

## OPTIONAL ATTACHMENTS AND DEVICES

### BLADE

#### Avoid Hitting Blade with Front-End Attachment

When operating the machine with the blade positioned towards the front, the bucket or boom cylinder may come into contact with the blade if you are not careful. Be sure to prevent this from happening.



MZX5-12-025



MZX5-12-026

#### Avoid Hitting Blade with Bucket

When crowding the arm into a traveling or transporting position, be careful not to let the bucket hit the blade.



MZX5-12-026

#### Avoid Striking the Blade into a Rock

Do not attempt to strike large rocks with the blade, as doing so will damage the blade and the blade cylinders, shortening their operating lives.



MZX5-12-027

## OPTIONAL ATTACHMENTS AND DEVICES

### BLADE

#### Blade Maintenance

##### Greasing --- every 250 hours

Lubricate all fittings shown in the figure.

- Blade Joint Pins (2 points)
- Blade Cylinder Rod (2 points)
- Blade Cylinder Bottom (2 points)

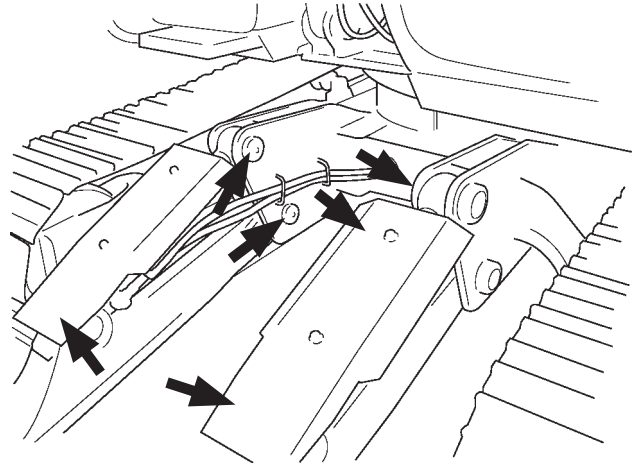

M175-13-002

#### Transportation Figure for Machine Equipped with Blade

When transporting the machine equipped with a blade and a long arm front attachment on a trailer, place the blade in the opposite position toward the front attachment. Otherwise, the bucket may come in contact with the blade.



M175-13-005



## OPTIONAL ATTACHMENTS AND DEVICES

### BLADE

#### Specifications

##### ZX135US-6 with Blade

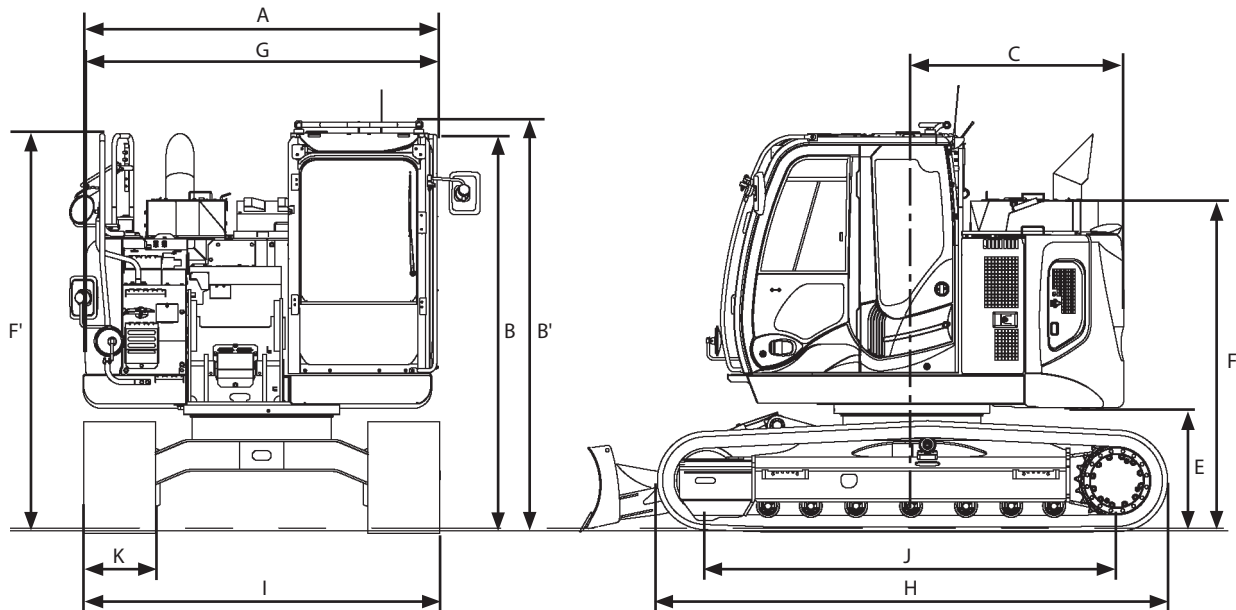

MDAT-13-003

Model	ZX135US-6 with Blade
Type of Front-End Attachment	2.52 m Arm
Bucket Capacity (Heaped)	PCSA 0.50 m <sup>3</sup> , CECE 0.45 m <sup>3</sup>
Counterweight Weight	3520 kg
Operating Weight	15100 kg
Base Machine Weight	11500 kg
Engine Type	Isuzu AR-4JJ1XASA-02
Engine Power	ISO 14396: 74.9 kW/2000 min <sup>-1</sup> (102 PS/2000 rpm)
A: Overall Width (Excluding back mirrors)	2490 mm
B: Cab Height	2790 mm
B': Cab Top Handrail Height	2870 mm
C: Rear End Swing Radius	1490 mm
D: Minimum Ground Clearance	*410 mm
E: Counterweight Clearance	*840 mm
F: Engine Cover Height	*2320 mm
F': Body Top Handrail Height	2870 mm
G: Overall Width of Upperstructure	2490 mm
H: Undercarriage Length	3580 mm
I: Undercarriage Width	2490 mm
J: Sprocket Center to Idle Center	2880 mm
K: Track Shoe Width	500 mm (Grouser Shoe)
Ground Pressure	47 kPa (0.48 kgf/cm <sup>2</sup> )
Swing Speed	13.5 min <sup>-1</sup> (rpm)
Travel Speed (fast/slow)	5.5/3.3 km/h
Gradeability	35 ° (tanθ = 0.70)

NOTE: \* The dimensions do not include the height of the shoe lug.

## OPTIONAL ATTACHMENTS AND DEVICES

### BLADE

#### Working Ranges

##### ZX135US-6 with Blade

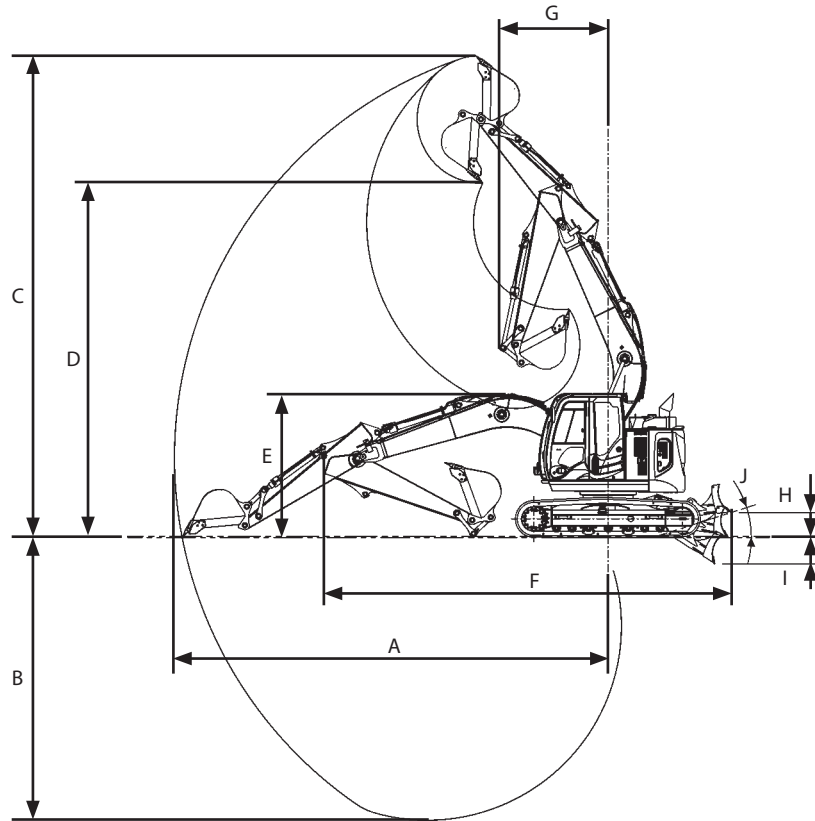

MDAT-13-002

Model		ZX135US-6 with Blade	
Category		2.52 m Arm	3.01 m Arm
Item			
A: Maximum Digging Reach	mm	8390	8860
B: Maximum Digging Depth	mm	5490	5980
C: Maximum Cutting Height	mm	9290	9690
D: Maximum Dumping Height	mm	6830	7220
E: Overall Height	mm	2870	*2870
F: Overall Length	mm	7890	7900
G: Minimum Swing Radius	mm	2110	2450
H: Max. Raising Height	mm	460	
I: Max. Digging Depth	mm	540	
J: Blade Angle	degree	27	

**NOTE:** The dimensions do not include height of the shoe lug (except Item E). \* The dimensions asterisked are for transport pin position.

## OPTIONAL ATTACHMENTS AND DEVICES

### BLADE

#### Shoe Types and Applications

##### ZX135US-6 with Blade

Shoe Width		500 mm Grouser Shoe	600 mm Grouser Shoe	700 mm Grouser Shoe
Application		For Ordinary Ground (Standard)	For Weak Footing (Option)	For Weak Footing (Option)
Operating Weight	kg	15100	15700	16100
Base Machine Weight	kg	11500	12100	12500
Counterweight Weight	kg	3520	3520	3520
Cab Height	mm	2790	2790	2790
Minimum Ground Clearance	mm	*410	*410	*410
Undercarriage Length	mm	3580	3580	3580
Undercarriage Width	mm	2490	2590	2690
Ground Pressure		47 kPa (0.48 kgf/cm <sup>2</sup> )	41 kPa (0.42 kgf/cm <sup>2</sup> )	36 kPa (0.37 kgf/cm <sup>2</sup> )

 **NOTE:**

- *The Specifications for the front-end attachment is for 2.52 m arm with PCSA 0.50 m<sup>3</sup> bucket.*
- *Other than 500 mm grouser shoe should not be used on gravel or rocky ground.*
- *\* The dimensions do not include the height of the shoe lug.*

## OPTIONAL ATTACHMENTS AND DEVICES

### BLADE

#### Specifications

##### ZX225USLC-6 with Blade

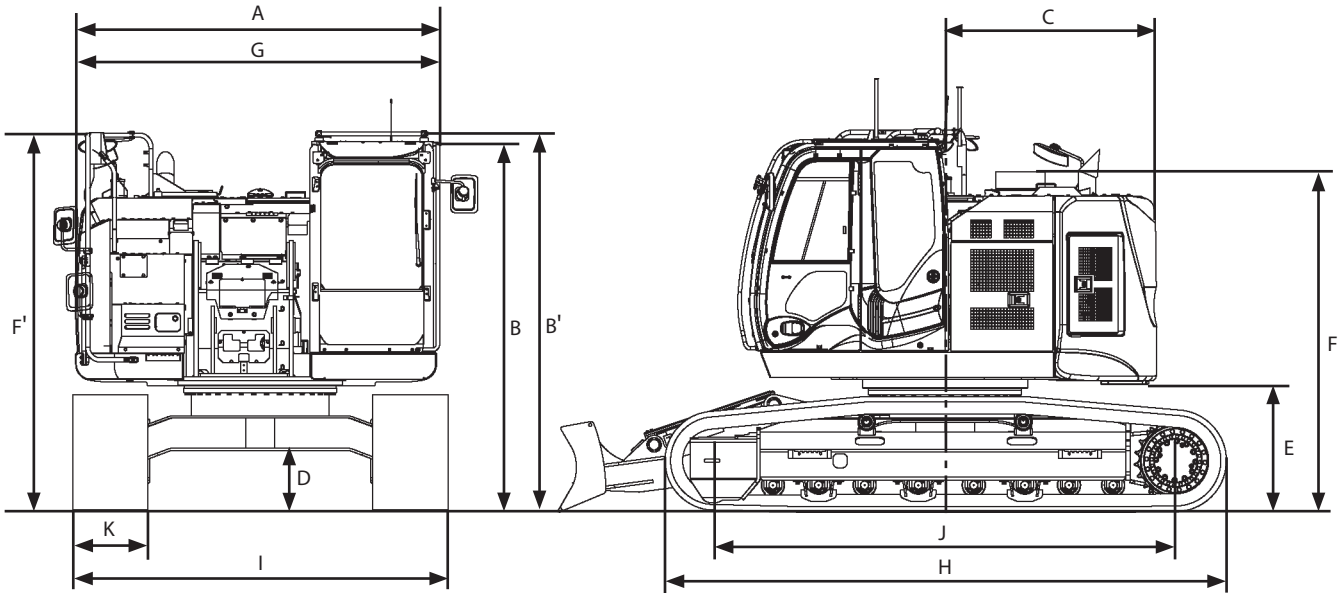

MDAT-13-004

Model	ZX225USLC-6 with Blade
Type of Front-End Attachment	2.91 m Arm
Bucket Capacity (Heaped)	PCSA 0.80 m <sup>3</sup> , CECE 0.70 m <sup>3</sup>
Counterweight Weight	6860 kg
Operating Weight	27200 kg
Base Machine Weight	22400 kg
Engine Type	Isuzu AR-4HK1XASA-12
Engine Power	ISO 14396: 122 kW/2000 min <sup>-1</sup> (166 PS/2000 rpm)
A: Overall Width (Excluding back mirrors)	2990 mm
B: Cab Height	2990 mm
B': Cab Top Handrail Height	3030 mm
C: Rear End Swing Radius	1680 mm
D: Minimum Ground Clearance	*450 mm
E: Counterweight Clearance	*980 mm
F: Engine Cover Height	*2670 mm
F': Body Top Handrail Height	3020 mm
G: Overall Width of Upperstructure	2910 mm
H: Undercarriage Length	4460 mm
I: Undercarriage Width	2990 mm
J: Sprocket Center to Idle Center	3660 mm
K: Track Shoe Width	600 mm (Grouser shoe)
Ground Pressure	57 kPa (0.58 kgf/cm <sup>2</sup> )
Swing Speed	11.8 min <sup>-1</sup> (rpm)
Travel Speed (fast/slow)	5.5/3.4 km/h
Gradeability	35 ° (tanθ = 0.70)

 NOTE: \* The dimensions do not include the height of the shoe lug.

## OPTIONAL ATTACHMENTS AND DEVICES

### BLADE

#### Working Ranges (Grouser shoe)

##### ZX225USLC-6 with Blade

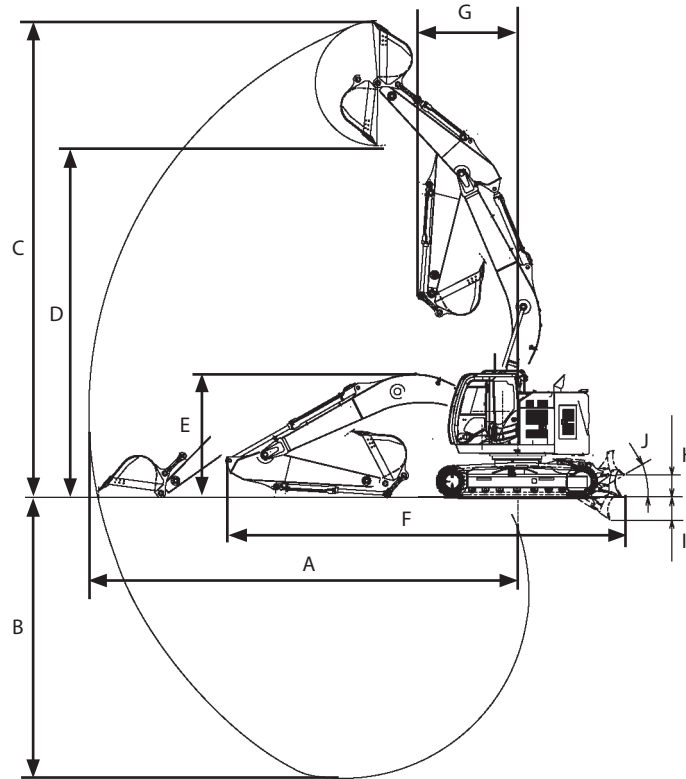

MDCN-13-015

Model		ZX225USLC-6 with Blade	
Category		2.42 m Arm	2.91 m Arm
Item			
A: Maximum Digging Reach	mm	9620	10110
B: Maximum Digging Depth	mm	6120	6620
C: Maximum Cutting Height	mm	10790	11230
D: Maximum Dumping Height	mm	7870	8290
E: Overall Height	mm	3230	2980
F: Overall Length	mm	9270	9110
G: Minimum Swing Radius	mm	2720	2380
H: Max. Raising Height	mm	570	
I: Max. Digging Depth	mm	300	
J: Blade Angle	degree	25	

**NOTE:** The dimensions do not include height of the shoe lug (except Item E).

## OPTIONAL ATTACHMENTS AND DEVICES

### BLADE

#### Shoe Types and Applications

##### ZX225USLC-6 with Blade

Shoe Width	600 mm Grouser Shoe	700 mm Grouser Shoe	800 mm Grouser Shoe
Application	For Ordinary Ground (Standard)	For Weak Footing (Option)	For Weak Footing (Option)
Operating Weight	kg 27500	27900	28200
Base Machine Weight	kg 22400	22800	23100
Counterweight Weight	kg 6860	6860	6860
Cab Height	mm 2950	2950	2950
Minimum Ground Clearance	mm *450	*450	*450
Undercarriage Length	mm 4460	4460	4460
Undercarriage Width	mm 2990	3090	3190
Ground Pressure	57 kPa (0.58 kgf/cm <sup>2</sup> )	50 kPa (0.51 kgf/cm <sup>2</sup> )	44 kPa (0.45 kgf/cm <sup>2</sup> )

 **NOTE:**

- The specifications for the front-end attachment is for 2.91 m arm with PCSA 0.8 m<sup>3</sup> bucket.
- 700 mm and 800 mm grouser shoe should not be used on gravel or rocky ground.
- \* The dimensions do not include the height of the shoe lug.

## OPTIONAL ATTACHMENTS AND DEVICES

### BUCKET TEETH

---

#### Bucket Teeth (Transverse-Type-Pin-Used Type)

##### Replacement Procedure

**⚠ CAUTION:** Guard against injury from flying pieces of metal. Wear goggles or safety glasses.

1. Securely lower the bucket to the ground.
2. Use hammer (3) and drift (2) to drive out transverse-type locking pin (1) to remove tooth (4).

**✎ NOTE:** Be sure to use a drift (2) thinner than pin (1).

3. Clean shank (5) surface. Attach a new tooth (4) onto shank (5). Insert pin (1) as deep as it goes. Then, drive pin (1) using hammer (3) and drift (2) to securely lock tooth (4).

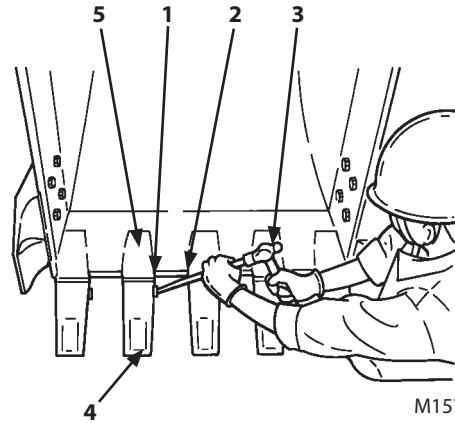

M157-14-013

# OPTIONAL ATTACHMENTS AND DEVICES

## BUCKET TEETH

### Control Lever (4 Way Multi Valve) (Optional)

The control lever operation pattern is selected to one of four patterns, Y-type (ISO pattern), H-type (Hitachi pattern), M-type and K-type by shifting selector valve (1).

**! WARNING:** To prevent a serious accident or personal injury and/or death from occurring due to erratic machine movement, follow the instructions below.

- Appoint a coordinator responsible to selection of the multi control lever operation pattern.
- Attach a lock (2) to selector valve (1). Prohibit that no personnel other than the coordinator change the control lever operation pattern.
- After changing the control lever operation pattern, check that the direction of the machine movement agrees with the control lever operation pattern described on the operation instruction decal. Be sure to change the operation instruction decal to that matching the new machine control lever operation pattern. The control lever operation pattern decal is affixed on the right side of the operator's seat as illustrated to the right.
- Never attempt to change the control lever operation pattern without stopping the engine. The machine may be unexpectedly moved, possibly resulting in personal injury or death. Whenever changing the control lever operation pattern, lower bucket to the ground, stop the engine. Then, rotate selector valve (1) to the desired control lever operation pattern position and lock the valve up.
- After changing the control lever operation pattern, make it rule for the coordinator to instruct the operator the new control lever operation pattern.
- Rule that the coordinator is responsible to retain and stow the key for selector valve lock (2).
- Never place any part of body beyond window frame. It could be crushed by the boom if boom control lever is accidentally bumped or otherwise engaged. If window is missing or broken, replace immediately.

Prevent possible injury from unexpected machine movement.

Make sure you know the location and function of each control before operating.

When a lever is released, it will automatically return to neutral, and that machine function will stop.

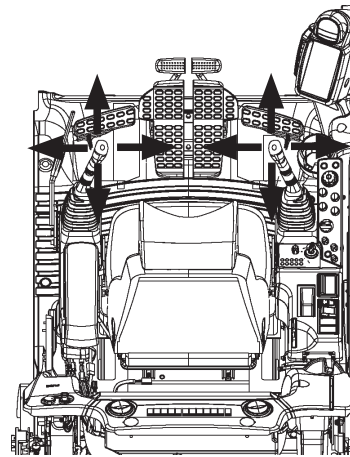

MDAA-01-343

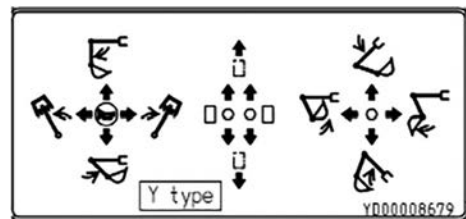

SSYD00008679

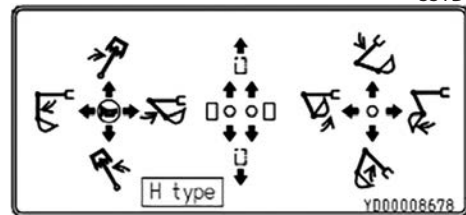

SSYD00008678

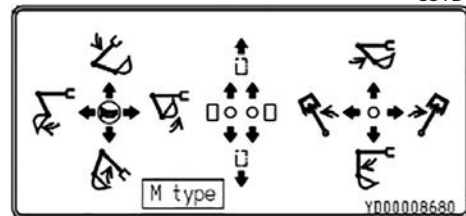

SSYD00008680

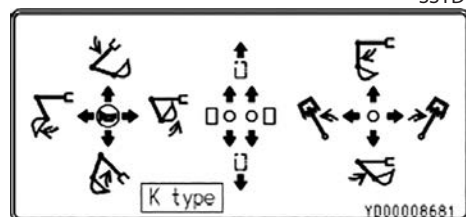

SSYD00008681

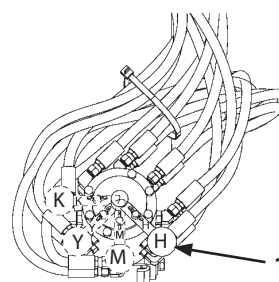

M178-05-013

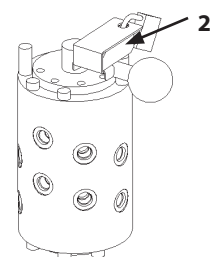

M1U1-01-117



## OPTIONAL ATTACHMENTS AND DEVICES

### HYDRAULIC BREAKER, HYDRAULIC CRUSHER AND QUICK COUPLER

---

#### Hydraulic Breaker, Hydraulic Crusher and Quick Coupler

**⚠ WARNING:** A standard specification machine is not intended to be used in applications such as demolition for which additional safety measures are necessary (e.g. protective guards, glazing). Consult your authorized dealer for information on available parts.

#### Selecting a Breaker, Crusher or Quick Coupler

Select a breaker, crusher or quick coupler with the correct size and weight for your machine, considering the stability of the machine, hydraulic oil pressure and flow rate of the breaker, crusher or quick coupler. See your authorized dealer for correct breaker information.

#### Precautions for Operation

Thoroughly read and understand the operator's manuals of the breaker, crusher and quick coupler.

To avoid damaging the machine, hydraulic breaker, crusher or quick coupler, follow the precautions given below.

When the hydraulic breaker, crusher or quick coupler is changed, make sure there is no risk related to the field of vision.

#### Precautions for Connecting Breaker, Crusher or Quick Coupler Piping.

Do not allow impurities to enter into the system when switching the breaker, crusher or the quick coupler with the bucket.

When the breaker, crusher or quick coupler is not used, apply the cover to the pipe opening on the arm top and install the plug or cap into the hose end of the breaker, crusher or the quick coupler to prevent impurities from entering the system.

Be sure to provide spare caps and plugs in the tool box so that they will be available when needed.

After connecting, check the connecting seal fitting for oil leakage, and pipe clamp bolts for looseness.

# OPTIONAL ATTACHMENTS AND DEVICES

## HYDRAULIC BREAKER, HYDRAULIC CRUSHER AND QUICK COUPLER

### Piping for Breaker and Crusher

#### Operational Procedures for Stop Valves and Selector Valve.

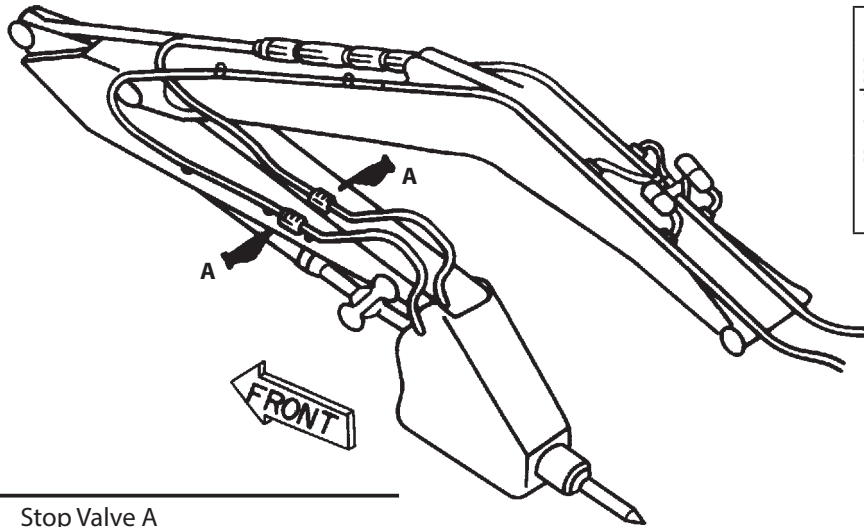

Stop Valves A	Close	
	Open	

Stop Valve A

Close: When attachment is detached or not in use.

Open: When using attachment

M1U1-05-007

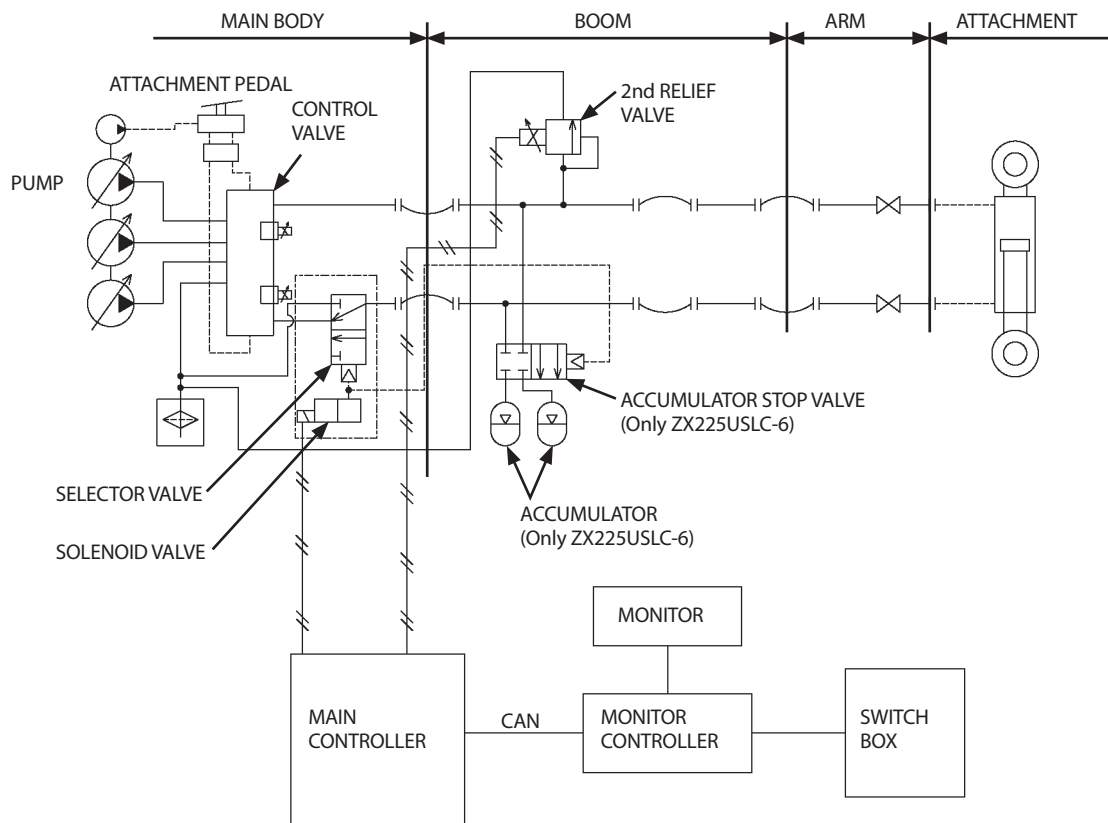

MDAA-05-006

## **OPTIONAL ATTACHMENTS AND DEVICES**

### **HYDRAULIC BREAKER, HYDRAULIC CRUSHER AND QUICK COUPLER**

---

---

#### **Secondary Relief Pressure Adjustment**

Depending on the breaker model, the secondary relief valve relief set pressure differs.

Consult your nearest Hitachi dealer for installing a breaker.

## OPTIONAL ATTACHMENTS AND DEVICES

### HYDRAULIC BREAKER, HYDRAULIC CRUSHER AND QUICK COUPLER

#### Precautions for Breaker Operation

**⚠ WARNING:** Machine stability is reduced as the breaker is much heavier than the bucket. When using a breaker, the machine is more likely to tip over. Also, flying objects may hit the cab or other parts of the machine. Observe the following precautions and take any other precautions necessary to prevent accidents and machine damage from occurring.

#### Avoid Hitting Objects with Breaker

The breaker is heavier than the bucket, causing the breaker to lower faster.

Take care not to hit any objects with breaker. Doing so will result in damage to the breaker, the front attachment, and/or the upperstructure. Always move (lower) the breaker slowly to position the tip of the chisel on the object to be broken before starting breaker operation.



MZX5-13-019

#### Avoid Moving Objects with Breaker

Do not use the breaker and/or the bracket to move objects. Damage to the boom, arm, and/or breaker may result.

Do not use the breaker and/or the swing function to move objects. Damage to the boom, arm, and/or breaker may result.



MZX5-13-020

#### Avoid Operating Breaker at Cylinder Stroke End

Always operate the breaker by positioning the cylinder rods 100 mm or longer before the stroke end position.

When operating the breaker with cylinders fully retracted or extended, hydraulic cylinders, arm or boom may be damaged.

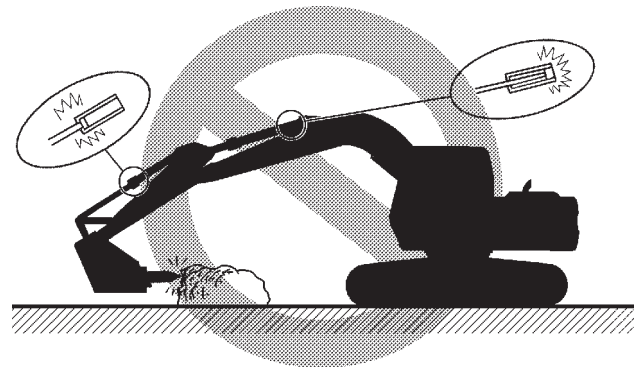

MZX5-13-021

## OPTIONAL ATTACHMENTS AND DEVICES

### HYDRAULIC BREAKER, HYDRAULIC CRUSHER AND QUICK COUPLER

#### Stop Operation If Breaker Hydraulic Hoses Jump Abnormally

Change in breaker accumulator pressure or a damaged accumulator will cause abnormal hose jumping and may cause breaker and/or machine damage. Immediately stop the machine operation. Failure to do so may result in serious failure in the hydraulic system including pumps. Contact your nearest Hitachi dealer.

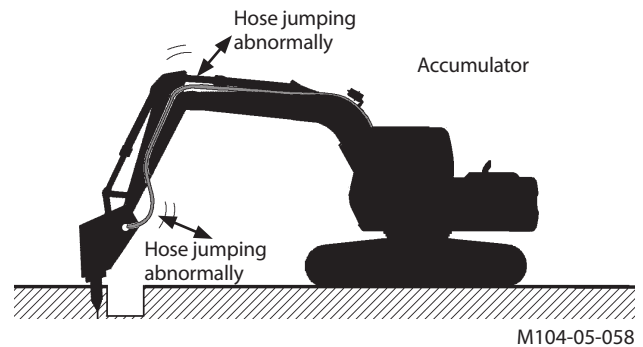

#### Do Not Operate the Breaker in Water

Doing so will cause rust and seal damage, resulting in damage to the hydraulic system components. Rust, dust and water may enter into the hydraulic oil through the broken seal, damage to the hydraulic system may result.

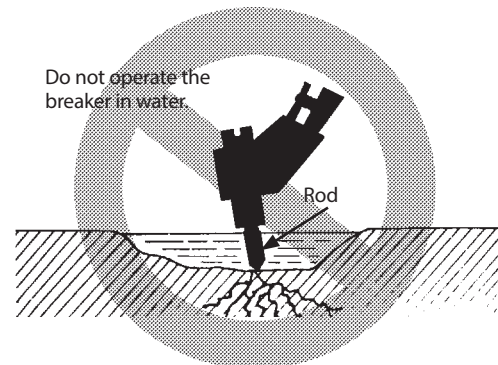

#### Do Not Use Breaker for Lifting Operation

The machine tipping over and/or breaker damage may result.

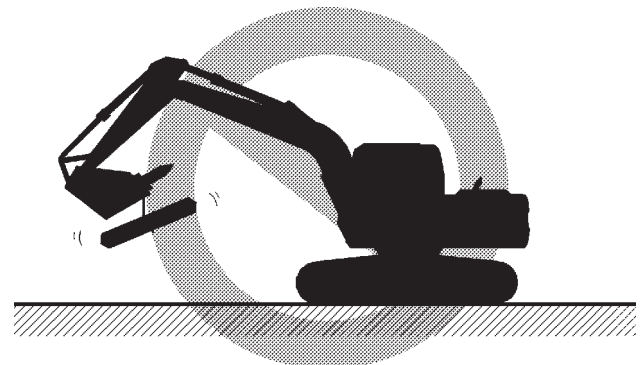

#### Do Not Operate the Breaker to the Side of the Machine

The machine may become unstable and undercarriage component life may shorten as a result from operating the breaker to the side of the machine.

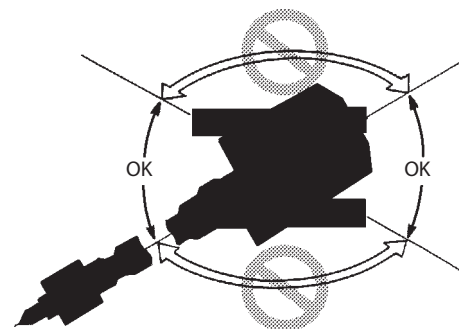

## OPTIONAL ATTACHMENTS AND DEVICES

### HYDRAULIC BREAKER, HYDRAULIC CRUSHER AND QUICK COUPLER

#### Operate the Hydraulic Excavator Carefully to Avoid Hitting the Boom

When the arm rolled in with the breaker equipped, the chisel may come in contact with the boom.

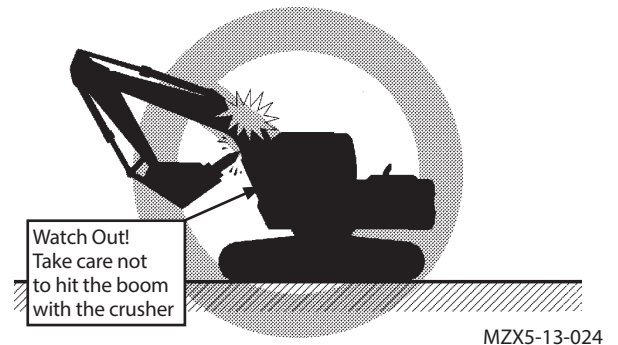

#### Do Not Operate Breaker with the Arm Positioned Vertically

Excessive vibration to the arm cylinder will occur, causing oil leakage.

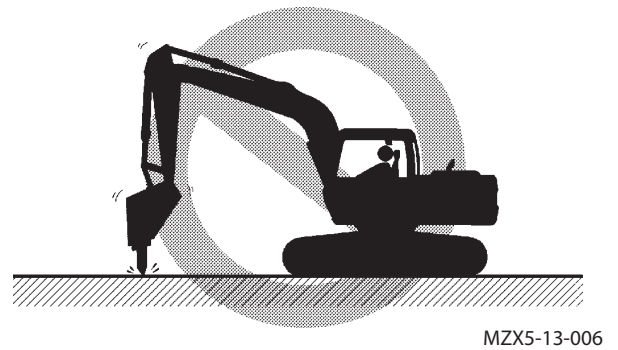

#### Press the Breaker so Chisel Axis Is Positioned Vertically Over the Object

Failure to do so may damage the chisel or may cause a piston to seize.

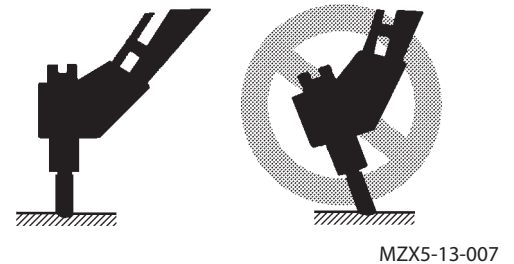

#### Do Not Continuously for Operate the Breaker Longer than One Minute

Failure to do so may result in premature wear of the chisel. If an object cannot be broken within one minute, apply the chisel to other locations for less than one minute in each location.

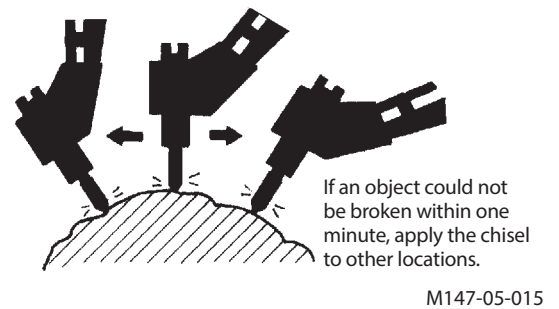

**IMPORTANT:** When the breaker is operated longer than one minute, a diagonal line will be displayed on work mode display (1) and the buzzer will sound. If so, immediately stop operation and wait a while to restart.

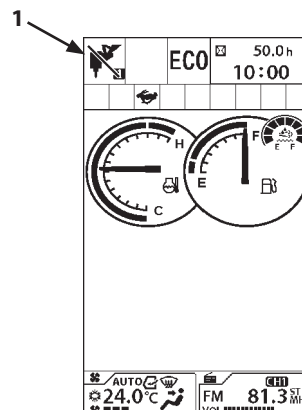

MDC1-13-001

## OPTIONAL ATTACHMENTS AND DEVICES

### HYDRAULIC BREAKER, HYDRAULIC CRUSHER AND QUICK COUPLER

---

#### Raising the Front Part of the Undercarriage by Pressing Down the Breaker May Cause Damage to the Front Attachment

Never raise the front edge of the undercarriage higher than 150 mm by pressing the breaker down.

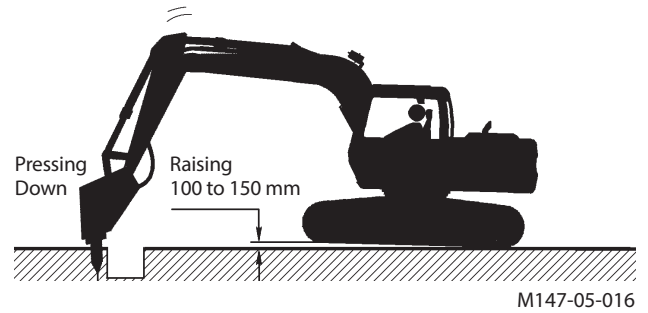

#### Machine storing position with breaker

After operating the machine, be sure to place the breaker horizontally on the ground. Do not leave cylinders at their stroke end position. Failure to do so may damage the cylinder.

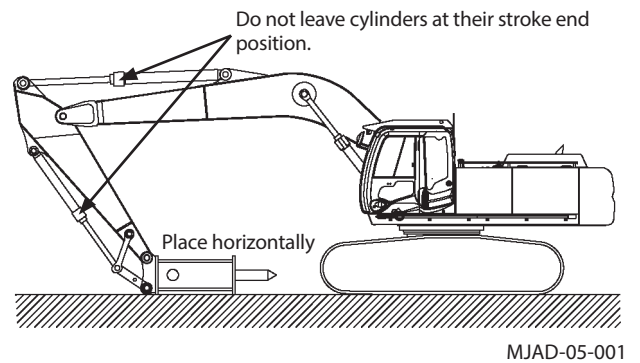

## OPTIONAL ATTACHMENTS AND DEVICES

### HYDRAULIC BREAKER, HYDRAULIC CRUSHER AND QUICK COUPLER

---

#### **Change Hydraulic Oil and Replace Full-Flow Filter Element**

Hydraulic breaker operation results in faster contamination of the hydraulic system, and faster deterioration of hydraulic oil. Failure to comply with proper maintenance intervals may result in damage to the base machine and the breaker. Change the hydraulic oil and the full-flow filter element in order to extend the service life particularly of the hydraulic pump. (Refer to the section "Hydraulic System" in the "MAINTENANCE" chapter.)

Change intervals differ depending on the brand of hydraulic oil used. Refer to the "Hydraulic System" in the "MAINTENANCE" chapter.

Use the high performance element (micro-glass) on excavators engaged in demolition and logging work.

 **NOTE:** *Hydraulic oil filter restriction alarm indicator is optional. If a filter-paper element is used, this indicator does not operate. (Refer to the section "Hydraulic System" in the "MAINTENANCE" chapter.)*



## OPTIONAL ATTACHMENTS AND DEVICES

### HYDRAULIC BREAKER, HYDRAULIC CRUSHER AND QUICK COUPLER

#### Precautions for Crusher Operation

Prevent machine tipping over and damage to the front attachment. Observe the following precautions for crusher operation.

**⚠ WARNING: Machine stability is reduced as the crusher is much heavier than bucket. When operating with a crusher, the machine is more likely to tip over. Falling or flying objects may hit the cab or other parts of the machine. Observe the following precautions and take any other precautions necessary to prevent accidents and machine damage from occurring.**

- Do not allow the machine's weight to be supported by the crusher or bucket cylinder with the bucket cylinder fully extended or retracted. Failure to do so may result in damage to the front attachment. In particular, avoid supporting the machine's weight with the bucket cylinder fully extended, as the front attachment will be easily damaged.  
Take care to prevent this happening when dismantling foundation structures using the crusher.
- Using the front attachment, do not raise the base machine off the ground with the arm cylinder fully extended. Failure to do so may result in damage to the arm cylinder.
- When a heavyweight attachment such as a crusher is installed, avoid quickly starting or stopping the front attachment. Failure to do so may result in damage to the front attachment.
- Do not attempt to perform crushing on either side of the machine. Always perform crushing operations to the front or rear, parallel with the tracks. Failure to do so may result in the machine tipping over.



MZX5-13-008



MZX5-13-009

## OPTIONAL ATTACHMENTS AND DEVICES

### HYDRAULIC BREAKER, HYDRAULIC CRUSHER AND QUICK COUPLER

- When the arm is rolled in with the crusher equipped, the crusher may come into contact with the boom.

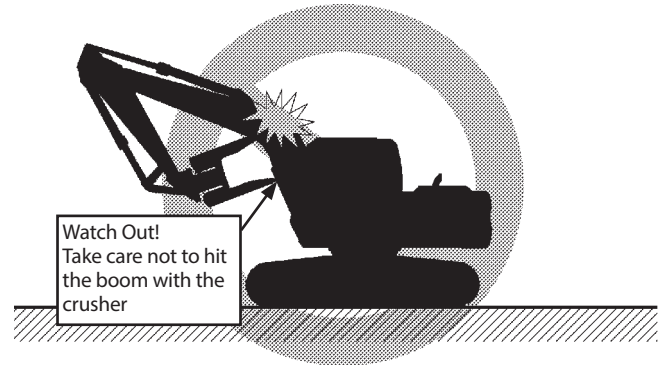

MZX5-13-010

- When operating the crusher with the boom fully raised, be careful of falling objects.



MZX5-13-011

- When operating the crusher on the floor in a building, first confirm that the floor has sufficient strength to support the load caused by crushing, in addition to the machine weight.  
Depending on the operation method, a load higher than the machine weight may be applied to the floor.

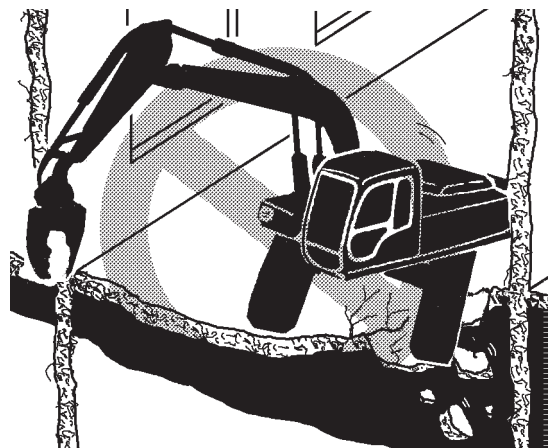

MZX5-13-012

## **OPTIONAL ATTACHMENTS AND DEVICES**

### **HYDRAULIC BREAKER, HYDRAULIC CRUSHER AND QUICK COUPLER**

---

- Always operate the crusher on a stable, level surface, not on a slope or on crushed debris.
- Do not use the crusher to haul or load crushed debris.
- If a multiple number of attachments, such as crusher and bucket, or crusher and breaker, are used, replacing them with each other at intervals, impurities are more apt to enter the hydraulic system and the hydraulic oil deteriorates quickly. For this reason, replace the hydraulic oil tank filter and change the hydraulic oil at the intervals specified in the breaker time sharing diagram in the previous section.
- Always remove the crusher from the excavator before transporting the machine. Do not fully extend the bucket cylinder when transporting, as this may damage the front attachment, when vibrations arise during transportation.

## OPTIONAL ATTACHMENTS AND DEVICES

### HYDRAULIC BREAKER, HYDRAULIC CRUSHER AND QUICK COUPLER

#### Attachment

##### Allowable Weight Limits of Installed Attachment

**⚠ WARNING:**

- Before installing attachments such as hydraulic breaker, crusher (concrete crusher), or pulverizer, take machine controllability into account when selecting the weight of the attachment by referring to the table below.
- When an attachment other than the standard bucket is installed on the machine, the machine stability will be different.
- According to the specifications of installed attachment and the base machine, the machine weight may exceed the allowable maximum operating weight of the ROPS, making the ROPS unable to assure the protective function for operator. Refer to the ROPS certification for the allowable maximum operating weight.

**If a heavy attachment is used, not only will controllability be affected but also machine stability will be reduced, possibly causing safety hazard.**

Unit: kg

Specification	Base Machine		Breaker		Crusher/Pulverizer	
	Model	Arm	Std.Weight	Max.Weight	Std.Weight	Max.Weight
Std. Model	ZX135US-6	Std.	1000	1100	1200	1400
	ZX225USLC-6	Std.	1750	1950	2100	2450
	ZX345USLC-6	Std.	2400	2650	2900	3400

## **OPTIONAL ATTACHMENTS AND DEVICES**

### **HYDRAULIC BREAKER, HYDRAULIC CRUSHER AND QUICK COUPLER**

---

- Breaker operation speed is faster than crusher operation, so that recommended maximum weight for breaker are lower than those for crushers.
- Weight is not the only factor to be considered when selecting a breaker. Select manufacturer's breaker models referring to the table on the next page.
- Avoid installing an attachment with a long overall length. Damage to the front attachment may result.
- When an attachment of the maximum weight is installed, always operate the attachment over the front or rear side of the machine. Avoid operating the attachment at maximum reach.
- Crushers are heavier than breakers. Slowly move the control lever when operating a crusher.
- Always contact your authorized dealer before installing attachments of other manufacturers.

## OPTIONAL ATTACHMENTS AND DEVICES

### HYDRAULIC BREAKER, HYDRAULIC CRUSHER AND QUICK COUPLER

#### Attachment Connection Parts

The attachment hydraulic line and connection parts are located as illustrated below.

When the attachment is disconnected, be sure to install caps or plugs to the ends of both the arm and attachment side hydraulic lines to prevent dust from entering or from sticking.

Adapter tightening torque:  
PF1: 210 N·m (21 kgf·m)

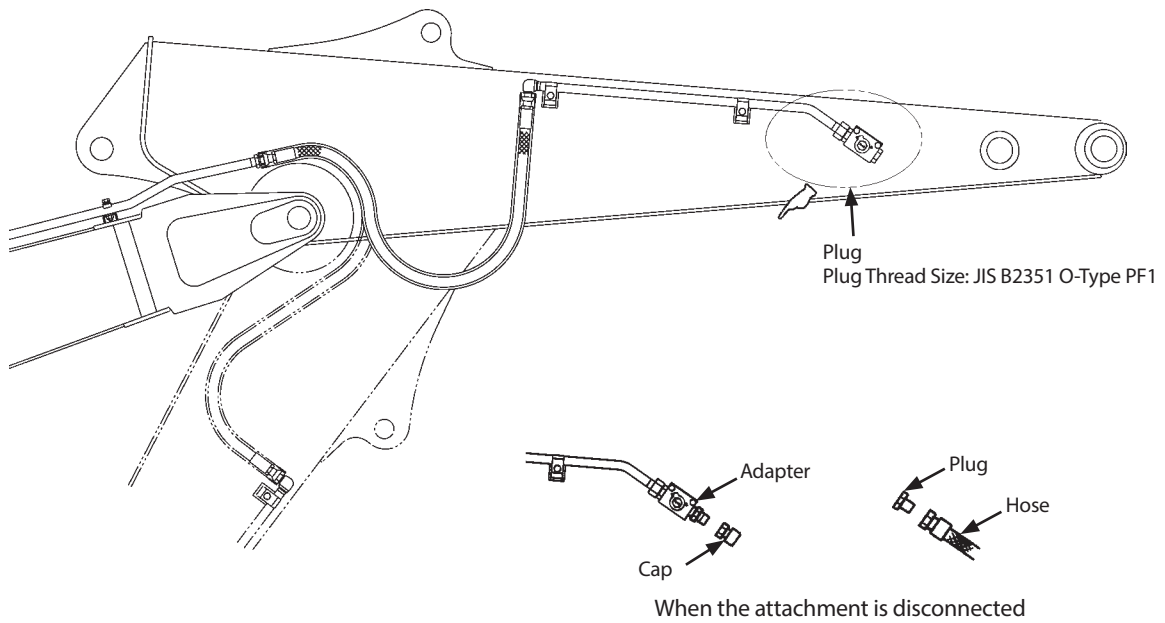

M175-05-005

## OPTIONAL ATTACHMENTS AND DEVICES

### HYDRAULIC BREAKER, HYDRAULIC CRUSHER AND QUICK COUPLER

Part No. List (Fill attachment manufacturer's part Nos. in the blank spaces.)

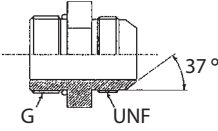
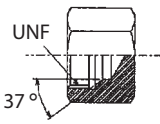
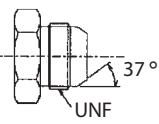
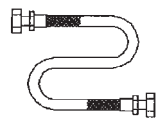
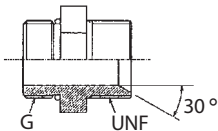
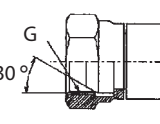
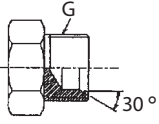
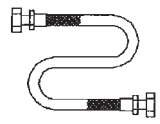
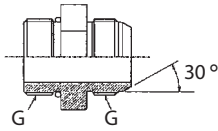
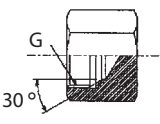
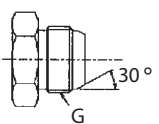
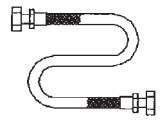
Form / Size	Adapter Size	Adapter	Cap	Plug	Hose
Form / Size	PF-UNF Male-Type				
ZX135US-6	PF1-1-1/16UN	4456399	4222711	4222264	
ZX225USLC-6, 345USLC-6 left side piping	PF1X1-5/16UN	4214444	4222712	4222265	
Form / Size	PF-PF30° Female-Type				
ZX135US-6	PF1-PF3/4	4129457	9718916	4222047	
ZX225USLC-6, 345USLC-6 left side piping	PF1XPF1	4042034	9718917	4168177	
Form / Size	PF-PF30° Male-Type				
ZX135US-6	PF1-PF3/4	4456120	4222715	4222044	
ZX225USLC-6, 345USLC-6 left side piping	PF1XPF1	4456118	4222716	4222045	

## OPTIONAL ATTACHMENTS AND DEVICES

### HYDRAULIC BREAKER, HYDRAULIC CRUSHER AND QUICK COUPLER

---

#### Precautions for Arm Roll-In/Bucket Roll-In Combined Operation

##### When Installing an Attachment Longer Than Standard Bucket

- ⚠ WARNING:** If an attachment (such as a hydraulic breaker, crusher or quick coupler) is installed that has a longer overall length than that of the bucket, the attachment may come into contact with the cab and/or the boom. Do not to allow the tip of the front attachment to hit the cab and/or the boom while rolling in the front attachment.

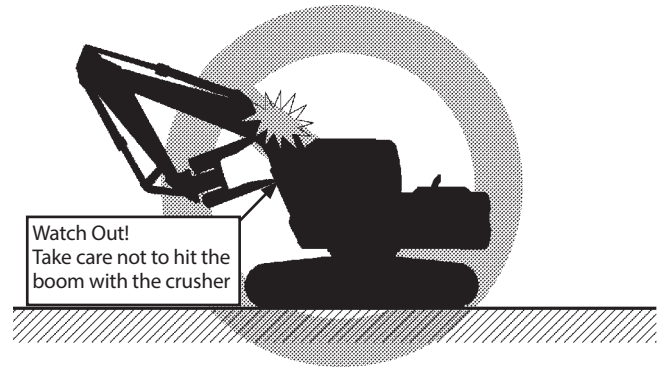

MZX5-13-010





## INDEX

- A**
- About Aftertreatment Device .....1-3
  - Actual operation ..... 1-84
  - Adjust Bucket Linkage .....7-113
  - Adjust the Operator's Seat .....5-6
  - Adjusting Operator's Seat ..... 1-144
  - Adjusting Operator's Seat (Optional) ..... 1-146
  - Adjusting Procedures.....1-148
  - Adjusting Seat Height.....1-146
  - Aerial Angle .....7-173
  - Aerial Angle Monitor .....1-126
  - After the First 100 Hours.....2-1
  - After the First 50 Hours .....2-1
  - Aftertreatment Device..... 1-26, 7-157
  - Aftertreatment Device Condition Display ..... 1-26
  - Aftertreatment Device Manual Regeneration ..... 5-10
  - Aftertreatment Device Manual Regeneration Request..... 1-27
  - Aftertreatment Device Regeneration Inhibited ..... 1-56
  - Air Cleaner .....7-90
  - Air Conditioner ..... 1-34
  - Air Conditioner ON/OFF..... 1-34
  - Alarm Occurrence Screen..... 1-19
  - Allowable Weight Limits of Installed Attachment.....13-31
  - AM/FM Radio Operation.....1-121
  - AM/FM Selector/Tuning Switch (Radio) ..... 1-94
  - Angle Adjustment of Seat Surface ..... 1-147
  - Armrest Adjustment..... 1-145, 1-147
  - Attachment.....13-31
  - Attachment Adjustment..... 1-42
  - Attachment Connection Parts .....13-33
  - Attachment Name Input..... 1-52
  - Attachment Operation ..... 1-80
  - Attachment Selection..... 1-36
  - Audio Input.....1-125
  - Auto Air Conditioner .....1-113
  - Auto Shut-Down ..... 1-54, 5-7
  - Auto Shut-Down: ON/OFF..... 1-54
  - Auto Shut-Down: Setting Time..... 1-55
  - AUTO/OFF Switch/Fan Switch (Air Conditioner) ..... 1-93
  - Auto-Idle.....5-5
  - Auto-Idle Function .....5-5
  - Auto-Idle ON/OFF.....5-6
  - Auto-Idle Switch ..... 1-95
  - AUX Function Lever 1.....1-106
  - Avoid Abusive Operation ..... 5-21
  - Avoid Applying Heat to Lines Containing Flammable Fluids.....5-35
  - Avoid Hammer Work .....5-20
  - Avoid Heating Near Pressurized Fluid Lines .....5-35
  - Avoid High-Pressure Fluids .....5-30
  - Avoid Hitting Blade with Front-End Attachment.....13-10
  - Avoid Injury from Attachment Falling Accident .....5-29
  - Avoid Injury from Back-Over and Swing Accidents .....5-17
  - Avoid Injury from Rollaway Accidents.....5-16
  - Avoid Power Lines.....5-21
  - Avoid Tipping..... 5-19
  - Avoid Undercutting ..... 5-19
- B**
- BREAK-IN.....2-1
  - Backrest Adjustment ..... 1-145, 1-147
  - Basic Screen..... 1-10
  - Battery .....7-105
  - Battery Charger Operation..... 7-39, 7-48
  - Battery Disconnect Switch.....1-158
  - Before Starting Engine .....3-3
  - Beware of Asbestos and Silica Dust and Other Contamination..... 5-36
  - Beware of Exhaust Fumes..... 5-33
  - Blade Lever ..... 13-9
  - Blade Maintenance .....13-11
  - Bleed Air from the Hydraulic System ..... 7-70
  - Brand Names of Recommended Grease ..... 7-21
  - Brand Names of Recommended Hydraulic Oil..... 7-22
  - Brand Names of Recommended Oil ..... 7-22
  - Breaker Operation ..... 1-48
  - Brightness Adjustment..... 1-64
  - Bucket Teeth (Transverse-Type-Pin-Used Type) .....13-18
  - Bucket Types and Applications ..... 12-4, 12-8, 12-12
    - ZX135US-6..... 12-4
    - ZX225USLC-6..... 12-8
    - ZX345USLC-6.....12-12
- C**
- Cab Door Release Lever .....1-133
  - Cab Features..... 1-6, 1-7
  - Cab Heater Operation.....1-117
  - Cab Light Switch.....1-108
  - Change Bucket .....7-115
  - Change Coolant ..... 7-98
  - Change DEF/AdBlue® .....7-168
  - Change Engine Oil ..... 7-55
  - Change Hydraulic Oil ..... 7-68
  - Change Hydraulic Oil and Replace Full-Flow Filter Element .....13-27
  - Charger Lamps ..... 7-39, 7-48
  - Check Air Conditioner.....7-128
  - Check and Adjust Fan Belt Tension ..... 7-96
  - Check and Clean Aftertreatment Device .....7-161
  - Check and Clean Around the Engine ..... 7-59
  - Check and Clean Injector.....7-132
  - Check and Replace Bucket Teeth .....7-113
  - Check and Replace EGR Device.....7-131
  - Check and Replace Seat Belt.....7-118
  - Check Coolant Level ..... 7-94
  - Check DEF/AdBlue® .....7-164
  - Check Electrolyte Specific Gravity .....7-109
  - Check Engine Oil Level ..... 7-53
  - Check Fuel Hoses..... 7-89
  - Check Gas Damper .....7-132
  - Check Hoses and Lines..... 7-75
  - Check Hydraulic Oil Level..... 7-67

## INDEX

Check Instruments After Starting.....	3-10
Check Starter and Alternator.....	7-131
Check the Hour Meter Regularly.....	7-5
Check Track Sag.....	7-120
Check Turbo Charger.....	7-131
Check Windshield Washer Fluid Level.....	7-119
Checking Aerial Angle Camera Images.....	7-174
Cigar Lighter.....	1-111
Circulation Air Mode.....	1-34
Clean Air Conditioner Condenser.....	7-102
Clean and Replace Air Cleaner Element (Outer).....	7-90
Clean and Replace Air Conditioner Filter.....	7-125
Clean Cab Floor.....	7-130
Clean Filler Port Strainer.....	7-167
Clean Fuel Oil Cooler.....	7-102
Clean Oil Cooler, Radiator and Inter Cooler	
Front Screen.....	7-102
Clean Radiator/Oil Cooler/Inter Cooler Core.....	7-100
Clock.....	1-14
Components Name.....	7-38, 7-47
Confirm Direction of Machine to Be Driven.....	5-13
Console and Seat Fore-aft Adjustment.....	1-144, 1-146
Console Height Adjustment.....	1-148
Control Lever (4 Way Multi Valve) (Optional).....	13-19
Control Lever (ISO Pattern).....	5-1
Control Lever Auto-Lock.....	1-110
Controller Part Name and Function.....	1-115
Controls on the Radio.....	1-121
Convert Bucket Connection Into Face Shovel.....	7-116
Cool Head/Warm Feet Operation.....	1-119
Coolant Temperature Gauge.....	1-16
Cooling Operation.....	1-118
Cooling System.....	7-93
Correct Maintenance and Inspection Procedures.....	7-1
<b>D</b>	
DRIVING THE MACHINE.....	4-1
Daily Checks of Aerial Angle Camera Images.....	7-173
Date Adjustment.....	1-42
Date and Time.....	1-40
DEF/AdBlue® Gauge.....	1-15
DEF/AdBlue® Level Alarm.....	1-15
Default Setting.....	1-9
Defroster Operation.....	1-119
Description of Images.....	1-129
Dig with Caution.....	5-20
Display Item Selection (Rear View Camera OFF).....	1-75
Display Mode Setting.....	1-44
Displaying Basic Screen.....	1-11
Dispose of Waste Properly.....	5-38
Do Not Strike the Ground with Bucket Teeth.....	5-20
Do Not Use Wide Track Shoes on Rough Ground.....	5-22
Drain Fuel Pre-Filter.....	7-82
Drain Fuel Tank Sump.....	7-81
Drain Intercooler (only ZX135US-6).....	7-103
Drive Machine Safely.....	5-14
<b>E</b>	
EGR Cooler Cleaning.....	7-131
Electric Grease Gun.....	7-37, 7-46
Electric Grease Gun (Lithium-ion Battery)	
(Only ZX345US-6 class).....	7-44
Electric Grease Gun (Nickel-Cadmium Battery)	
(Only ZX345US-6 class).....	7-35
Electrical Control Main Switch.....	1-103, 1-105
Electrical System.....	7-104
Emergency Exit.....	1-142
Engine.....	7-53
Engine Auto-Stop in Extremely Low Temperature.....	3-14
Engine Control Dial.....	1-94
Engine Output Restriction Suspend.....	1-30
Engine Speed Control.....	5-4
Engine Stop Switch.....	1-111
Ensure Safety Before Rising from or	
Leaving Operator's Seat.....	5-7
Evacuating in Case of Fire.....	5-33
Every 8 Hours or Daily.....	2-1
Extending Password Duration Time.....	1-18
<b>F</b>	
Fasten Your Seat Belt.....	5-7
Fastening Machine for Transporting.....	6-5
Features:.....	1-113
Flow Rate Adjustment.....	1-46
Follow Safety Instructions.....	5-2
For Rapid Cooling.....	1-120
Fore-Aft Position Adjustment of Seat Surface.....	1-147
Front Joint Pins.....	7-30
Fuel Consumption.....	1-76
Fuel Gauge.....	1-14
Fuel System.....	7-79
Fuse Box.....	1-112, 7-111
<b>G</b>	
GETTING ON AND OFF THE MACHINE.....	1-2
General Precautions for the Cab.....	5-5
Grading Operation.....	5-19
Greasing.....	7-30
<b>H</b>	
Handle Chemical Products Safely.....	5-38
Handle Fluids Safely—Avoid Fires.....	5-24
Hood and Access Covers.....	7-11
Horn Switch.....	1-104
Hour Meter.....	1-14
How to clean the screen.....	1-140
How to Lower Boom in Case of Emergency and	
When Engine Stops.....	5-25
How to Store on Right Window Side.....	1-140
How to Use on Right Window Side.....	1-140
How to Use on the Front Window.....	1-138
How to Use Screens.....	1-11
Hydraulic Breaker, Hydraulic Crusher and	
Quick Coupler.....	13-20

## INDEX

Hydraulic System.....	7-64	Numeric Keypad.....	1-99
<b>I</b>		<b>O</b>	
Information Menu.....	1-75	OPERATING THE ENGINE.....	3-1
Input Password.....	1-17	OPERATING THE MACHINE.....	5-1
Inspect and Adjust Valve Clearance.....	7-131	OPERATOR'S STATION.....	1-3
Inspect Machine.....	5-4	OPTIONAL ATTACHMENTS AND DEVICES.....	13-1
Inspect Machine Daily Before Starting.....	3-1	Object Handling.....	5-22
Inspection and Maintenance of		Observe Engine Operation Closely.....	2-1
Hydraulic Equipment.....	7-64	Off-Season Air Conditioner Maintenance.....	1-120
Install OPG Guard.....	5-12	Opening and Closing the OPG Front Guard	
Installation and Adjustment of Mirrors.....	1-149	(Optional).....	1-144
Investigate Job Site Beforehand.....	5-11	Opening and Closing the Roll Screen	
<b>J</b>		(for Front and Right Windows) (Optional).....	1-138
JJump Starting.....	5-9	Opening Side Window.....	1-137
<b>K</b>		Opening Upper Front Window.....	1-135
Keep People Clear from Working Area.....	5-18	Opening/Closing and Removing Cab	
Keep Riders off Machine.....	5-9	Inside Window.....	1-134
Key Switch.....	1-104	Opening/Closing Overhead Window (Clear Hatch).....	1-141
Kind of Oils.....	7-21	Operate Only from Operator's Seat.....	5-8
<b>L</b>		Operate with Caution.....	5-20
Language Settings.....	1-66	Operating Backhoe.....	5-17
Layout.....	7-3, 7-4	Operating in Water or Mud.....	4-6
Lifting Machine.....	6-7	Operating on Soft Ground.....	4-4
List of Consumable Parts.....	7-24	Operating Status Icon Display.....	1-16
Lists of Display Language.....	1-68	Operation.....	1-76
Loading/Unloading on a Trailer.....	6-2	Operational Procedures for Stop Valves and	
Long Arm Operation.....	13-8	Selector Valve.....	13-21
<b>M</b>		<b>P</b>	
MACHINE NUMBERS.....	1	Park Machine Safely.....	5-24
MAINTENANCE UNDER SPECIAL ENVIRONMENTAL		Parking the Machine.....	4-7
CONDITIONS.....	9-1	Parking the Machine on Slopes.....	4-7
Mail (Optional).....	1-37	Password Change (Optional).....	1-54
Main Menu.....	1-29	Perimeter Lights Switch (Optional).....	1-101
Main Menu Sequence Change.....	1-73	Periodic Replacement of Parts.....	7-20
Maintenance.....	1-86, 7-1	Pilot Accumulator Functions (Optional).....	5-24
Maintenance Guide.....	7-14	Pilot Control Shut-Off Lever.....	1-109, 5-2
Maintenance Guide Table.....	7-6	Piping for Breaker and Crusher.....	13-21
Manual Regeneration Procedure.....	1-28	Power Boost Switch.....	1-104, 5-15
Measure Engine Compression Pressure.....	7-131	Power Mode.....	5-16
Mirror Installation Diagram.....	1-150	Power Mode Switch.....	1-96
Miscellaneous.....	7-113	Power Switch/Volume Control Knob (Radio).....	1-94
Monitoring.....	1-90	Practice Safe Maintenance.....	5-26
Move and Operate Machine Safely.....	5-8	Precautions for After Operations.....	5-26
Multi Function Monitor.....	1-8	Precautions for Arm Roll-In/Bucket Roll-In Combined	
<b>N</b>		Operation.....	13-35
NAME OF COMPONENTS.....	1-1, 1-114	Precautions for Breaker Operation.....	13-23
Never Move an Object Sideways with the Bucket.....	5-21	Precautions for Communication Terminal.....	5-39
Never Position the Bucket Over Anyone.....	5-18	Precautions for Communication Terminal Equipment ...	5-40
Never Ride Attachment.....	5-39	Precautions for Crusher Operation.....	13-28
Never Undercut a High Bank.....	5-20	Precautions for Handling Accumulator and	
Notes on Aftertreatment Device.....	5-39	Gas Damper.....	5-35
Notes on Protection of Operator's Station when the		Precautions for Lightning.....	5-21
Machine Rolls Over.....	5-42	Precautions for Operations.....	5-10
		Precautions for Transporting Machines with	
		Pad Crawler Shoes.....	13-3
		Precautions for Welding and Grinding.....	5-34

## INDEX

Preparations for Inspection and Maintenance .....	7-10	ZX345USLC-6 .....	12-9
Prepare for Emergencies.....	S-3	ZX135US-6 with Blade .....	13-12
Prevent Battery Explosions .....	S-37	ZX225USLC-6 with Blade.....	13-15
Prevent Burns.....	S-29	STORAGE.....	10-1
Prevent Fires.....	S-31	Sampling the Engine Oil .....	7-69
Prevent Parts from Flying .....	S-28	Sampling the Engine Oil (Only ZX225USLC-6).....	7-58
Priority (arm roll-in) (Except ZX135US-6) .....	1-50	Seat Belt .....	1-147
Priority (arm roll-out) .....	1-48	Seat Fore-Aft Adjustment.....	1-144, 1-146
Prohibition of Sudden Control Operations when Traveling at High Speed .....	4-8	Seat Heater Switch (Optional).....	1-102
Prohibition of Traveling for Long Periods .....	4-8	Seat Height and Angle Adjustment.....	1-144
Protect Against Flying Debris and Falling Object .....	S-23	Secondary Relief Pressure Adjustment .....	13-22
Protect Against Noise .....	S-4	Security Functions (Optional) .....	1-17
Provide Signals for Jobs Involving Multiple Machines....	S-13	Selector Knob (Monitor) .....	1-93
Pump Transmission (Except ZX135US-6) .....	7-60	Service Air Conditioning System Safely .....	S-37
<b>R</b>		Setting Menu .....	1-39
Radio .....	1-35	Setting Procedure .....	1-56
Raising the Machine with Boom and Arm.....	4-4	Shackle Hole Usage .....	5-23
Rear Light Switch.....	1-101	Shoe Types and Applications .....	12-3, 12-7, 12-11, 13-14, 13-17
Recognize Safety Information .....	S-1	ZX135US-6.....	12-3
Recommended Engine Oil .....	7-21	ZX225USLC-6.....	12-7
Recommended Fuel .....	7-79	ZX345USLC-6.....	12-11
Recommended Oil Viscosity.....	7-23	ZX135US-6 with Blade .....	13-14
Refill DEF/AdBlue®.....	7-164	ZX225USLC-6 with Blade.....	13-17
Remaining Time and Maintenance Interval.....	1-88	Shovel .....	5-18
Remedy .....	1-21	Starting the Engine.....	3-4
Remove Paint Before Welding or Heating .....	S-36	Station Auto-Presetting Procedure.....	1-123
Remove Travel Levers.....	7-118	Station Presetting Procedure .....	1-122
Removing and Storing Lower Front Window.....	1-136	Stay Clear of Moving Parts .....	S-28
Replace Air Breather Element .....	7-74	Stopping the Engine .....	3-13
Replace Air Cleaner Element (Inner).....	7-92	Storing the Machine.....	10-1
Replace Battery .....	7-108	Suction Filter Cleaning .....	7-71
Replace DEF/AdBlue® Supply Module Main Filter .....	7-169	Support Machine Properly .....	S-27
Replace DEF/AdBlue® Tank Water Supply Inlet Filter.....	7-171	Suspension Adjustment.....	1-144, 1-147
Replace Engine Oil Filter.....	7-55	Swing Bearing.....	7-32
Replace Fuel Main Filter Element .....	7-85	Swing Internal Gear .....	7-33
Replace Fuel Pre-Filter Element .....	7-87	Swing Reduction Gear.....	7-61
Replace Full-Flow Filter .....	7-72	Switch Operation.....	1-160
Replace Oil Separator Element (Only ZX135US-6) .....	7-59	Switch Panel .....	1-92
Replace Pilot Oil Filter .....	7-73	Switch Panel (for Optional Equipments).....	1-100
Replace Rubber Hoses Periodically.....	S-30	Switching the Screen Display .....	1-128
Replace the DEF/AdBlue® back flow line filter .....	7-172	<b>T</b>	
Replacing Fuses .....	7-110	TRANSPORTING.....	6-1, 13-3
Restriction of Attachment Installation .....	S-12	TROUBLESHOOTING.....	11-1
Retighten Cylinder Head Bolt .....	7-131	Temperature Control Switch/Mode Switch (Air Conditioner).....	1-93
Retracting the Arm and Bucket.....	5-22	Tightening and Retightening Torque of Nuts and Bolts .....	7-132
Retrieval .....	4-5	Time Adjustment.....	1-40
Return to Basic Screen Switch (Monitor) .....	1-93	Tips for Optimal Air Conditioner Usage .....	1-120
Return to Previous Screen Switch (Monitor) .....	1-93	TONE Control .....	1-124
<b>S</b>		Transmission .....	7-60
SAFETY .....	S-1	Transport Safely .....	S-25
SAFETY SIGNS.....	S-49	Transporting by Road .....	6-1
SPECIFICATIONS.....	12-1, 12-5, 12-9, 13-12, 13-15	Travel Alarm (Optional) .....	4-3
ZX135US-6.....	12-1	Travel Alarm Deactivation Switch (Optional) .....	1-101
ZX225USLC-6.....	12-5		

---

---

## INDEX

---

---

Travel Levers and Pedals .....	4-1
Travel Mode Switch .....	1-95, 4-3
Travel Operation .....	1-82
Travel Reduction Gear .....	7-62
Traveling and Other Cautions .....	13-2
Tuning Procedure .....	1-121

### U

Understand Signal Words .....	S-1
Unit Selection .....	1-69
Unloading .....	6-6
Urea SCR System .....	7-158
Urea SCR System Remedy .....	1-24
Urea SCR System Troubleshooting .....	1-32
USB Power Supply Port .....	1-98
Use Handholds and Steps .....	S-6
Using Booster Batteries .....	3-11
Using Cigar Lighter .....	1-107
Using Pad Crawler Shoe .....	13-1

### V

VISIBILITY MAP .....	S-43
----------------------	------

### W

Warming-Up Operation .....	5-3
Warn Others of Service Work .....	S-27
Wear Protective Clothing .....	S-3
When Windows Become Misty .....	1-120
Wiper/Washer Switch .....	1-97
Work Light Switch .....	1-96
Work Mode .....	1-36, 5-12
Working Ranges .....	12-10, 13-13
ZX345USLC-6 .....	12-10
ZX135US-6 with Blade .....	13-13
Working Ranges (Grouser shoe) .....	12-2, 12-6, 13-16
ZX135US-6 .....	12-2
ZX225USLC-6 .....	12-6
ZX225USLC-6 with Blade .....	13-16

